

Silicon PNP Power Transistors

MJE4350/4351/4352/4353

DESCRIPTION

- With TO-3PN package
- Respectively complement to type MJE4340/4341/4342/4343
- DC current gain $h_{FE}=8(\text{Min})@I_C=16\text{A}$

APPLICATIONS

- For use in high power audio amplifier and switching regulator circuits

PINNING

PIN	DESCRIPTION
1	Base
2	Collector;connected to mounting base
3	Emitter

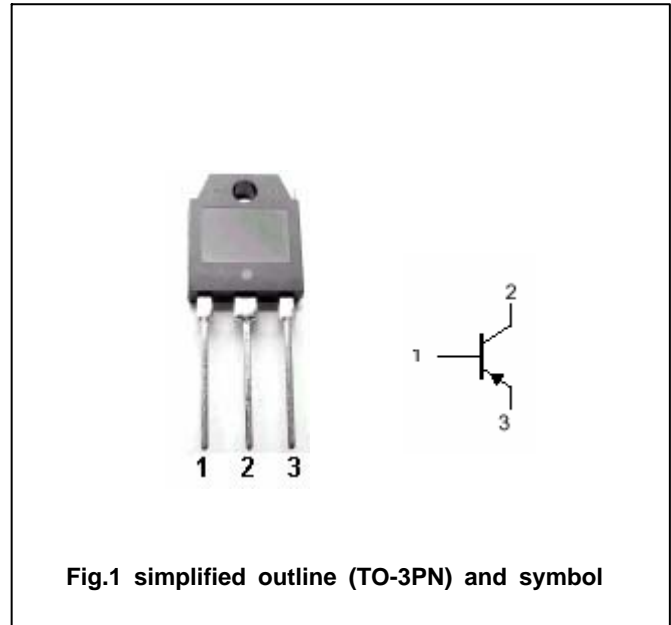

Fig.1 simplified outline (TO-3PN) and symbol

Absolute maximum ratings(Ta=)

SYMBOL	PARAMETER	CONDITIONS	VALUE	UNIT
V _{CB0}	Collector-base voltage	MJE4350	-100	V
		MJE4351	-120	
		MJE4352	-140	
		MJE4353	-160	
V _{CEO}	Collector-emitter voltage	MJE4350	-100	V
		MJE4351	-120	
		MJE4352	-140	
		MJE4353	-160	
V _{EBO}	Emitter-base voltage	Open collector	-7	V
I _C	Collector current		-16	A
I _{CM}	Collector current-peak		-20	A
I _B	Base current		-5	A
P _C	Collector power dissipation	T _C =25	125	W
T _j	Junction temperature		150	
T _{stg}	Storage temperature		-65~150	

THERMAL CHARACTERISTICS

SYMBOL	PARAMETER	MAX	UNIT
R _{th j-c}	Thermal resistance junction to case	1.0	/W

Silicon PNP Power Transistors

MJE4350/4351/4352/4353

CHARACTERISTICS

T_j=25 unless otherwise specified

SYMBOL	PARAMETER	CONDITIONS	MIN	TYP.	MAX	UNIT	
V _{CEO(SUS)}	Collector-emitter sustaining voltage	MJE4350	-100			V	
		MJE4351	-120				
		MJE4352	-140				
		MJE4353	-160				
V _{CEsat-1}	Collector-emitter saturation voltage	I _C =-8A ; I _B =-0.8A			-2.0	V	
V _{CEsat-2}	Collector-emitter saturation voltage	I _C =-16A ; I _B =-2.0A			-3.5	V	
V _{BEsat}	Base-emitter saturation voltage	I _C =-16A ; I _B =-2.0A			-3.9	V	
V _{BE}	Base-emitter on voltage	I _C =-16A ; V _{CE} =-4V			-3.9	V	
I _{CEO}	Collector cut-off current	MJE4350	V _{CE} =-50V ; I _B =0			-0.75	mA
		MJE4351	V _{CE} =-60V ; I _B =0				
		MJE4352	V _{CE} =-70V ; I _B =0				
		MJE4353	V _{CE} =-80V ; I _B =0				
I _{CEX}	Collector cut-off current	V _{CE} =RatedV _{CB0} ; V _{BE} =-1.5V T _C =150			-1.0 -5.0	mA	
I _{CB0}	Collector cut-off current	V _{CB} =RatedV _{CB} ; I _E =0			-0.75	mA	
I _{EBO}	Emitter cut-off current	V _{EB} =-7V ; I _C =0			-1.0	mA	
h _{FE-1}	DC current gain	I _C =-8A ; V _{CE} =-2V	15				
h _{FE-2}	DC current gain	I _C =-16A ; V _{CE} =-4V	8				
C _{OB}	Output capacitance	I _E =0 ; V _{CB} =-10V ; f=0.1MHz			800	pF	
f _T	Transition frequency	I _C =-1A ; V _{CE} =-20V ; f=0.5MHz	1.0			MHz	

Silicon PNP Power Transistors

MJE4350/4351/4352/4353

PACKAGE OUTLINE

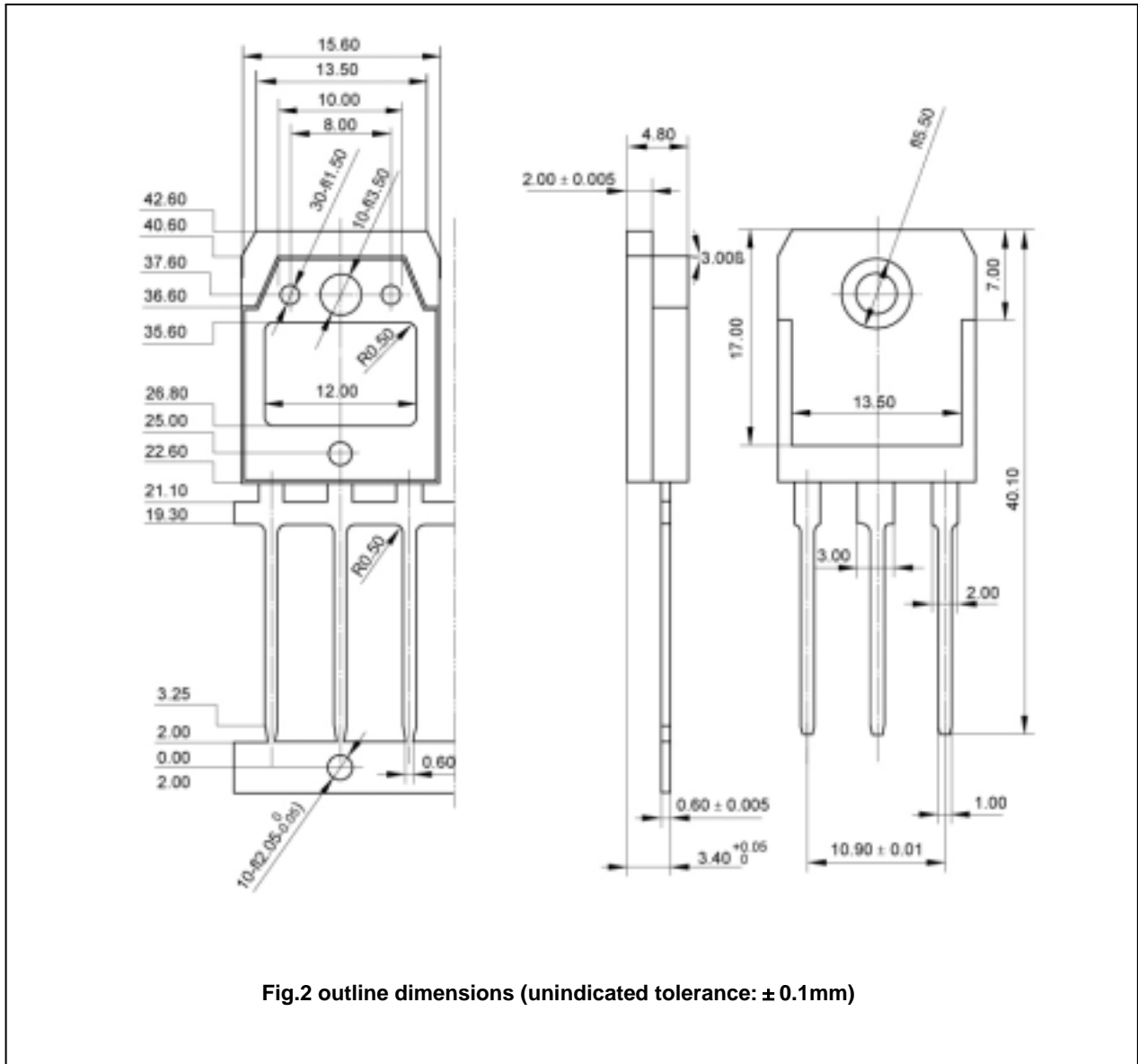

Fig.2 outline dimensions (unindicated tolerance: ± 0.1 mm)