

**SANYO Semiconductors**

# DATA SHEET

An ON Semiconductor Company

## LV8806GQ

### Bi-CMOS Integrated circuit IC 3-phase sensor-less Motor Driver IC

#### Overview

LV8806GQ is a 3-phase sensor-less motor driver IC.

3-phase driver allows low power consumption and low vibration. And Hall sensor-less drive allows reduction of the size of a motor system.

This IC is suitable for use in products which require high reliability and long life such as note PC fan.

#### Functions

- Built-in current limit circuit (Operates when RF resistance is  $0.5\Omega$  and  $I_o=0.53A$ )
- 3-phase full-wave sensor-less driver
- FG (rotation count) output signal pin
- Built-in lock protection and auto-recovery circuit
- Direct PWM input
- RD (lock detection) output signal pin
- Built-in TSD (thermal shutdown) circuit

#### Specifications

**Absolute Maximum Ratings** at  $T_a = 25^\circ\text{C}$

Parameter	Symbol	Conditions	Ratings	Unit
$V_{CC}$ maximum supply voltage	$V_{CC\ max}$		7	V
OUT pin maximum output current	$I_{OUT\ max}$		0.7	A
OUT(VO, VO, WO) pin withstand voltage	$V_{OUT\ max}$		7	V
FG output pin maximum sink current	$I_{FG\ max}$		5	mA
FG output pin withstand voltage	$V_{FG\ max}$		7	V
RD output pin maximum sink current	$I_{RD\ max}$		5	mA
RD output pin withstand voltage	$V_{RD\ max}$		7	V
Allowable power dissipation	$P_d\ max1$	IC only	150	mW
	$P_d\ max2$	With specified board *1	700	mW
Operating temperature	$T_{opr}$	*2	-40 to 95	$^\circ\text{C}$
Storage temperature	$T_{stg}$		-55 to 150	$^\circ\text{C}$

\*1: With specified board: 50mm×50mm×1.6mm, grass epoxy board / single layer.

\*2:  $T_{jmax}$  must not exceed  $150^\circ\text{C}$

Caution 1) Absolute maximum ratings represent the value which cannot be exceeded for any length of time.

Caution 2) Even when the device is used within the range of absolute maximum ratings, as a result of continuous usage under high temperature, high current, high voltage, or drastic temperature change, the reliability of the IC may be degraded. Please contact us for the further details.

- Any and all SANYO Semiconductor Co.,Ltd. products described or contained herein are, with regard to "standard application", intended for the use as general electronics equipment. The products mentioned herein shall not be intended for use for any "special application" (medical equipment whose purpose is to sustain life, aerospace instrument, nuclear control device, burning appliances, transportation machine, traffic signal system, safety equipment etc.) that shall require extremely high level of reliability and can directly threaten human lives in case of failure or malfunction of the product or may cause harm to human bodies, nor shall they grant any guarantee thereof. If you should intend to use our products for new introduction or other application different from current conditions on the usage of automotive device, communication device, office equipment, industrial equipment etc. , please consult with us about usage condition (temperature, operation time etc.) prior to the intended use. If there is no consultation or inquiry before the intended use, our customer shall be solely responsible for the use.
- Specifications of any and all SANYO Semiconductor Co.,Ltd. products described or contained herein stipulate the performance, characteristics, and functions of the described products in the independent state, and are not guarantees of the performance, characteristics, and functions of the described products as mounted in the customer's products or equipment. To verify symptoms and states that cannot be evaluated in an independent device, the customer should always evaluate and test devices mounted in the customer's products or equipment.

**SANYO Semiconductor Co., Ltd.**
<http://semicon.sanyo.com/en/network>

# LV8806GQ

## Recommended Operating Conditions at Ta = 25°C

Parameter	Symbol	Conditions	Ratings	Unit
V <sub>CC</sub> supply voltage	V <sub>CC</sub>		5.0	V
Operating V <sub>CC</sub> supply voltage range	V <sub>CC</sub> op		2.0 to 6.0	V
PWM input frequency range	f <sub>PWM</sub>		20 to 50	kHz

## Electrical Characteristics at Ta = 25°C, V<sub>CC</sub> = 5.0V

Parameter	Symbol	Conditions	Ratings			Unit
			min	typ	max	
Circuit current	I <sub>CC1</sub>	PWM=5V		1.5	2.5	mA
	I <sub>CC2</sub>	PWM=0V		10	50	μA
<b>Output circuit</b>						
ON-resistance of high-side output transistor	R <sub>ON(H)</sub>	I <sub>O</sub> =500mA		0.5	0.9	Ω
ON-resistance of low-side output transistor	R <sub>ON(L)</sub>	I <sub>O</sub> =500mA		0.5	0.9	Ω
Sum of the ON-resistance of high/low-side output transistor	R <sub>ON(H+L)</sub>	I <sub>O</sub> =500mA		1.0	1.8	Ω
<b>Startup oscillation (OSC) pin</b>						
OSC pin charge current	I <sub>OSCC</sub>	OSC=0V	-3.25	-2.50	-1.75	μA
OSC pin discharge current	I <sub>OSCD</sub>	OSC=1.2V	1.75	2.50	3.25	μA
OSC pin High level threshold voltage	V <sub>OSCTHH</sub>		1.0	1.1	1.2	V
OSC pin Low level threshold voltage	V <sub>OSCTHL</sub>		0.5	0.6	0.7	V
<b>PWM input (PWM) pin</b>						
PWM pin High level input voltage	V <sub>PWMH</sub>		2.5		V <sub>CC</sub>	V
PWM pin Low level input voltage	V <sub>PWML</sub>		0		1.0	V
PWM pin current	I <sub>PWM</sub>	PWM pin=0V	-50	-10		μA
<b>Forward/reverse switching (F/R) pin</b>						
F/R pin High level input voltage	V <sub>FRH</sub>		2.5		V <sub>CC</sub>	V
F/R pin Low level input voltage	V <sub>FRL</sub>		0		1.0	V
F/R pin current	I <sub>FR</sub>	FR pin=5V		10	50	μA
<b>FG, RD output pin</b>						
FG pin Low level voltage	V <sub>FG</sub>	I <sub>FG</sub> =3mA		0.2	0.3	V
FG pin leakage current	I <sub>FG</sub>	V <sub>FG</sub> =7V			10	μA
RD pin Low level voltage	V <sub>RD</sub>	I <sub>RD</sub> =3mA		0.2	0.3	V
RD pin leakage current	I <sub>RD</sub>	V <sub>RD</sub> =7V			10	μA
<b>Current limiter circuit</b>						
Limiter voltage	V <sub>RF</sub>	Operating when R <sub>F</sub> =0.5Ω, I <sub>O</sub> =0.53A	0.238	0.265	0.291	V
<b>Lock protection circuit</b>						
Output ON-time	LT1		0.35	0.50	0.65	S
Output OFF-time	LT2		3.2	4.5	5.9	S
Output ON/OFF ratio	LRTO	LRTO=LT2/LT1	4.9	9.0	16.8	
<b>Thermal shutdown circuit</b>						
Operating temperature	TSD	*Design guarantee	150	180		°C
Hysteresis width	ΔTSD	*Design guarantee		30		°C

\*Design guarantee: This is a design target value, which will not be measured independently.

# LV8806GQ

## Package Dimensions

unit : mm (typ)

3341

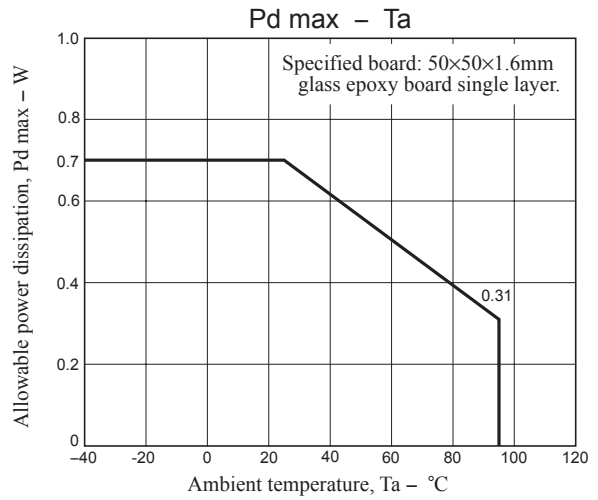
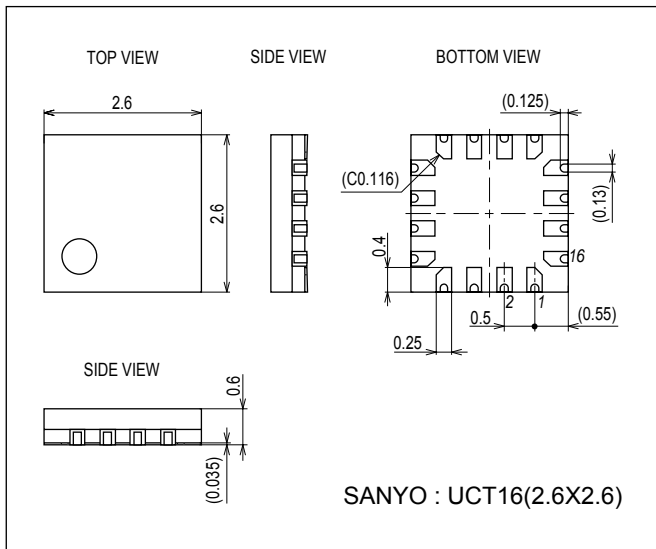

## Block Diagram

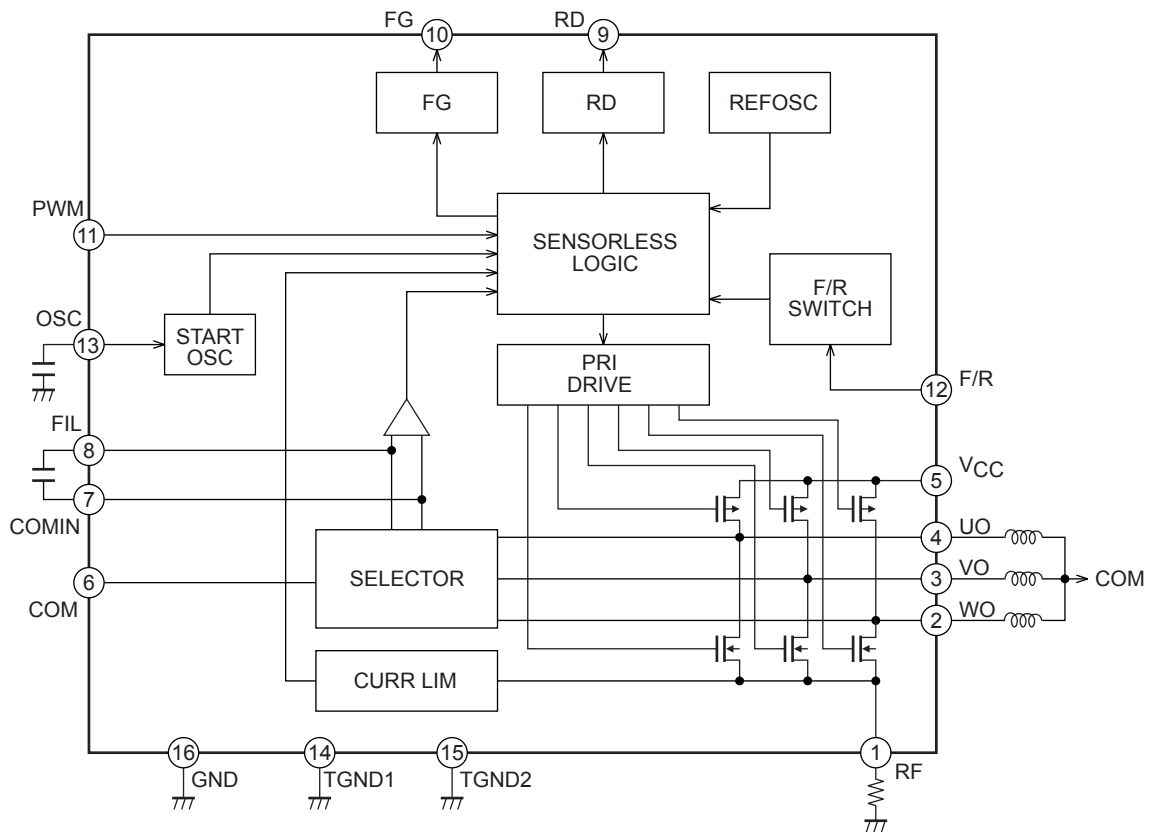

# LV8806GQ

## Pin Assignment

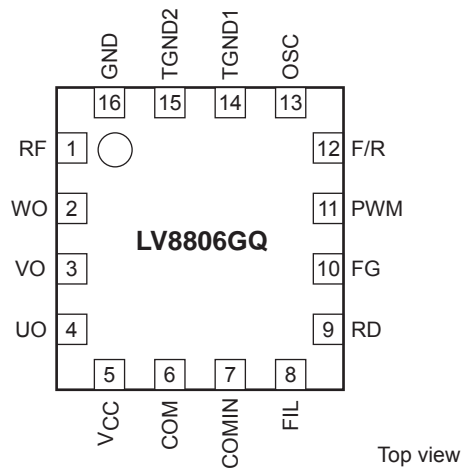

## Pin function

Pin No.	Symbol	Function	Equivalent circuit
1	RF	Output current detection pin. Drive current is detectable with resistors connected to GND.	
2	UO	Output pin.	
3	VO	Connected to motor coil.	
4	WO	Connected to motor coil.	
5	VCC	IC power supply pin and motor power supply pin. A capacitor is connected between GND and this pin.	
6	COM	Connected to the midpoint of the motor.	
7	COMIN	Motor position detection comparator filter pin. A capacitor is connected between FIL (PIN8) and this pin.	
8	FIL	Motor position detection comparator filter pin. A capacitor is connected between COMIN (PIN7) and this pin.	
9	RD	Motor lock detection output pin. Outputs High when motor is locked.	
10	FG	FG pulse output pin. This pin outputs pulse equivalent to one Hall sensor system pulse output.	
11	PWM	PWM signal input pin. When input voltage is High, output transistor turns on. When input voltage is Low, output transistors turn off, and motor stop. By controlling duty of input signal, motor rotation count is adjustable. Motor is full-speed when pin is open.	
12	F/R	Switches motor rotation direction. High level voltage input: U→W→V, Low level voltage input: U→V→W. Current flow into the motor according to the above order. Motor rotates reversely when the order of energization is changed.	
12	F/R	Switches motor rotation direction. High level voltage input: U→W→V, Low level voltage input: U→V→W. Current flow into the motor according to the above order. Motor rotates reversely when the order of energization is changed.	

Continued on next page.

# LV8806GQ

Continued from preceding page.

Pin No.	Symbol	Function	Equivalent circuit
13	OSC	Motor start-up frequency setting pin. A capacitor is connected between this pin and GND. The start-up frequency is adjustable with a capacitor and charge/discharge current (2.5μA).	
14	TGND2	GND pin of the IC	
15	TGND1		
16	GND		

## Application Circuit Example

(1) Application to Y-Connector Motor

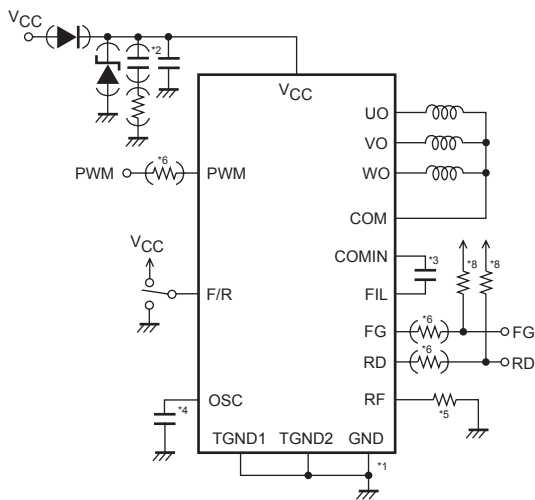

(2) Application to Delta-Connector Motor

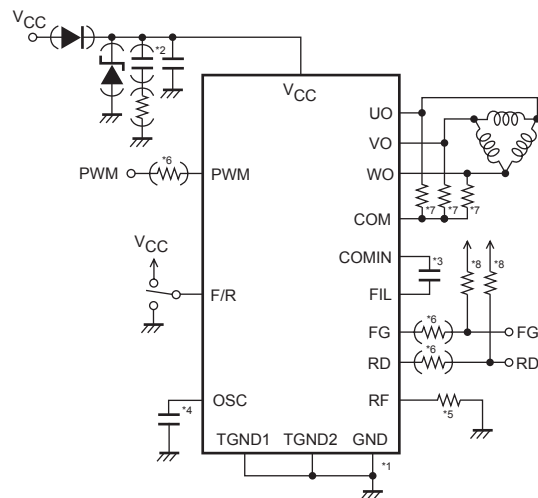

\*1. [Connection of power supply and GND]

GND is connected to the power supply line of control circuit.

\*2. [Power supply stabilizer capacitor]

The power supply stabilizer capacitor needs to be 4.7μA or higher. Connect V<sub>CC</sub> and GND as wide and short as possible. If the supply voltage increases due to the kickback of coil as a result of using reverse connection protector diode, make sure to connect Zener diode between the power supply and GND.

LV8806GQ uses synchronous rectification for high efficiency drive. Synchronous rectification is effective for heat reduction and higher efficiency. However, it may increase supply voltage under the following conditions:

- \*When output duty is reduced rapidly.
- \*PWM input frequency is low.

If the supply voltage shall increase, make sure that it does not exceed the maximum ratings with the following measures:

- \*Select an optimal capacitor between power supply and GND.
- \*Insert a zener diode between power supply and GND.

\*3. [COMIN and FIL]

COMIN and FIL are the filter capacitor connection pins. LV8806GQ detects the position of rotor using BEMF signal generated during motor rotation. Based on the information, current-carrying timing of the output is determined. By inserting a filter capacitor of about 1000 to 10000pF (recommendation) between COMIN and FIL, start-up failure caused by noise is alleviated. However, if the capacitance is too high, timing of current-carrying for output may be delayed during high-speed rotation and efficiency may be degraded.

Make sure that the filter capacitor is connected between COMIN and FIL as short as possible to avoid influence of noise.

\*4. [OSC]

Capacitor connection pin for setting boot frequency.

Make sure to connect a capacitor of 500pF to 2200pF (recommendation) between this pin and GND. The capacitor is required to determine boot frequency to start motor.

How to define capacitance:

The capacitance should allow the shortest boot time for the target rotation count and less variation. The higher the capacitance is, the more likely the variation occurs in boot time. On the other hand, the lower the capacitance is, the more likely an idling occurs. Since an optimum value for OSC pin constant varies depends on motor characteristics and boot current, make sure to confirm the constant when motor or circuit specification are changed.

\*5. [RF]

Current limit setting pin.

When a pin voltage exceeds 0.265V, current limiter operates and the mode shifts to regeneration mode.

The calculation formula is as follows.

RF resistance value = 0.265V / desired current limit value

\*6. [Pin protection resistor]

It is recommended that resistors higher than 1kΩ are connected serially to protect pins against misconnection such as GND open and reverse connection.

\*7. [Resistor for pseudo midpoint]

Delta connector motor does not have midpoint. Therefore, we need to create a pseudo midpoint by external resistor. Please note that the amplitude of BEMF signal generated during motor rotation varies depends on motor types. Some motors require the external pseudo midpoint and others do not.

\*8. [FG, RD pull-up resistor]

Since FG and RD are open-drain output, make sure to use pull-up resistors.

It is recommended that the pull-up resistor is approximately 10kΩ.

- SANYO Semiconductor Co.,Ltd. assumes no responsibility for equipment failures that result from using products at values that exceed, even momentarily, rated values (such as maximum ratings, operating condition ranges, or other parameters) listed in products specifications of any and all SANYO Semiconductor Co.,Ltd. products described or contained herein.
- SANYO Semiconductor Co.,Ltd. strives to supply high-quality high-reliability products, however, any and all semiconductor products fail or malfunction with some probability. It is possible that these probabilistic failures or malfunction could give rise to accidents or events that could endanger human lives, trouble that could give rise to smoke or fire, or accidents that could cause damage to other property. When designing equipment, adopt safety measures so that these kinds of accidents or events cannot occur. Such measures include but are not limited to protective circuits and error prevention circuits for safe design, redundant design, and structural design.
- In the event that any or all SANYO Semiconductor Co.,Ltd. products described or contained herein are controlled under any of applicable local export control laws and regulations, such products may require the export license from the authorities concerned in accordance with the above law.
- No part of this publication may be reproduced or transmitted in any form or by any means, electronic or mechanical, including photocopying and recording, or any information storage or retrieval system, or otherwise, without the prior written consent of SANYO Semiconductor Co.,Ltd.
- Any and all information described or contained herein are subject to change without notice due to product/technology improvement, etc. When designing equipment, refer to the "Delivery Specification" for the SANYO Semiconductor Co.,Ltd. product that you intend to use.
- Upon using the technical information or products described herein, neither warranty nor license shall be granted with regard to intellectual property rights or any other rights of SANYO Semiconductor Co.,Ltd. or any third party. SANYO Semiconductor Co.,Ltd. shall not be liable for any claim or suits with regard to a third party's intellectual property rights which has resulted from the use of the technical information and products mentioned above.

This catalog provides information as of August, 2011. Specifications and information herein are subject to change without notice.