

Document Title	HSD150MX49-A Product Information	Page No.	1 / 26
Document No.		Revision	1.0

To :

Date : No. 28, 2001

液晶之友 电话: 020-33819057
[Http://www.lcdfriends.com](http://www.lcdfriends.com)

HannStar Product Information

Model : **HSD150MX49**
-A

- Note: 1. Please contact HannStar Display Corp. before designing your product based on this module specification.
2. The information contained herein is presented merely to indicate the characteristics and performance of our products. No responsibility is assumed by HannStar for any intellectual property claims or other problems that may result from application based on the module described herein.



Document Title	HSD150MX49-A Product Information	Page No.	2 / 26
Document No.		Revision	1.0

Record of Revisions

Rev.	Date	Description of change
1.0	Nov, 2001	HSD150MX49-A Product Information was first issued.



Document Title	HSD150MX49-A Product Information	Page No.	3 / 26
Document No.		Revision	1.0

Contents

1.0	General description	p.4
2.0	Absolute maximum rating	p.5
3.0	Optical characteristics	p.6
4.0	Electrical characteristics	p.11
5.0	Block diagram	p.13
6.0	Interface pin connection	p.14
7.0	Interface timing	p.18
8.0	Outline dimension	p.22
9.0	Lot mark	p.25
10.0	General precaution	p.28

Document Title	HSD150MX49-A Product Information	Page No.	4 / 26
Document No.		Revision	1.0

1.0 GENERAL DESCRIPTION

1.1 Introduction

HannStar Display model HSD150MX49-A is a color active matrix thin film transistor (TFT) liquid crystal display(LCD) that uses amorphous silicon TFT as a switching device. This model is composed of a TFT LCD panel, a driving circuit and a back light system. This TFT LCD has a 15 inch diagonally measured active display area with XGA resolution (768 vertical by 1024 horizontal pixel array) and can display up to 16 million colors.

1.2 Features

- ‡ High brightness with low power consumption
- ‡ Wide viewing angle
- ‡ Compact and light weight design
- ‡ 2 CCFLs(Cold Cathode Fluorescent Lamp)
- ‡ Hsync, Vsync and DE mode
- ‡ LVTTTL interface with simulate 8-bit color data.(6-bit + FRC)

1.3 Applications

- ‡ Desktop monitors
- ‡ Moniputers
- ‡ Display terminals for AV applications
- ‡ Monitors for industrial applications

1.4 General information

Item	Specification	Unit
Display area	304.1(H) x 228.1(V)	mm
Number of Pixel	1024(H) x 768(V)	pixels
Pixel pitch	0.297(H) x 0.297(V)	mm
Pixel arrangement	RGB Vertical stripe	
Display color	16.2 million	colors
Display mode	Normally white	
Surface treatment	Antiglare, Hard-Coating(3H)	
Weight	(1050)	g
Back-light	2-CCFLs, Bottom edge side	
Input signal	LVTTTL interface with simulate 8-bit color data. (6-bit + FRC)	
Power consumption	TBD	W
Optimum viewing direction	6 o'clock	

Document Title	HSD150MX49-A Product Information	Page No.	5 / 26
Document No.		Revision	1.0

1.5 Mechanical Information

Item		Min.	Typ.	Max.	Unit
Module Size	Horizontal(H)	---	321	---	mm
	Vertical(V)	---	249	---	mm
	Depth(D)	---	11.5	TBD	mm
Weight (Without inverter)		---	(1050)	TBD	g

2.0 ABSOLUTE MAXIMUM RATING

2.1 Absolute Rating of Environment

Item	Symbol	Min.	Max.	Unit	Note
Storage temperature	T_{STG}	-20	60	°C	
Operating temperature	T_{OPR}	0	50	°C	
Vibration(non-operating)	V_{NOP}	--	1.5	G	(1)
Shock(non-operating)	S_{NOP}	--	70	G	(2)
Storage humidity	H_{STG}	10	90	%RH	(3)
Operating humidity	H_{OP}	10	80	%RH	(3)
Low pressure(operating)	P_{LOP}	697	--	hPa	(4)
Low pressure(non-operating)	P_{LNO}	116	--	hPa	(5)

- Note (1) 10-300Hz sweep/cycle, X,Y,Z each directions, 0.5hr each
(2) 11ms, $\pm X$, $\pm Y$, $\pm Z$ direction, one time each. For this shock test, it is necessary to fill the silicon rubber between the shock jig as buffer.
(3) Max wet bulb temp.=39°C
(4) 2hrs. (10000 feet)
(5) 24hrs. (50000 feet)

2.2 Electrical Absolute Rating

2.2.1 TFT LCD Module

Item	Symbol	Min.	Max.	Unit	Note
Power supply voltage	V_{DD}	-0.3	4.0	V	(1)
Logic input voltage	V_{IN}	-0.3	$V_{DD}+0.3$	V	(1)

2.2.2 Back-Light Unit

Item	Symbol	Min.	Max.	Unit	Note
Lamp voltage	V_L	0	2000	V_{rms}	(1)
Lamp current	I_L	--	7.5	mA	(1)
Lamp frequency	f_L	0	100	kHz	(1)

Document Title	HSD150MX49-A Product Information	Page No.	6 / 26
Document No.		Revision	1.0

Note (1) Permanent damage may occur to the LCD module if beyond this specification. Functional operation should be restricted to the conditions described under normally operating conditions.

3.0 OPTICAL CHARACTERISTICS

3.1 Optical specification

Item		Symbol	Condition	Min.	Typ.	Max.	Unit	Note	
Contrast		CR	=0° F=0° Normal viewing angle	--	(350)	--		(1)(2)	
Response time	Rising	T _R		--	T _R +T _F	--	msec	(1)(3)	
	Falling	T _F		--	=(35)	--			
White luminance (center of screen)		Y _L			--	(250)	--	cd/m ²	(1)(4)
Color chromaticity (CIE1931)	Red	R _x			--	TBD	--		
		R _y			--	TBD	--		
	Green	G _x			--	TBD	--		
		G _y			--	TBD	--		
	Blue	B _x			--	TBD	--		
		B _y			--	TBD	--		
White	W _x		--	(0.31)	--				
	W _y		--	(0.33)	--				
Viewing angle	Hor.	L	CR>10	--	(60)	--			
		R		--	(60)	--			
	Ver.	U		--	(40)	--			
		D		--	(50)	--			
Viewing angle	Hor.	L	CR>5	(70)	--	--			
		R		(70)	--	--			
	Ver.	U		(45)	--	--			
		D		(60)	--	--			
Brightness uniformity		B _{UNI}	=0°	(70)	(75)	--	%	(5)	
Crosstalk		CT(n)	F=0°	--	--	1.3	%	(6)	

3.2 Measuring Condition

- ‡ Measuring surrounding : dark room
- ‡ Lamp current I_{BL}: 6.0±0.1mA, lamp freq. F_L=50kHz.
- ‡ V_{DD}=3.3V, f_V=60Hz, f_{DCLK}=32.5MHz
- ‡ Surrounding temperature : 25±2°C
- ‡ 30min. warm-up time.

Document Title	HSD150MX49-A Product Information	Page No.	7 / 26
Document No.		Revision	1.0

3.3 Measuring Equipment

- ‡ LCD-7000 of Otsuka Electronics Corp., which utilized MCPD-7000 for Chromaticity and BM-5A for other optical characteristics.
- ‡ Measuring spot size : 10~12mm

Note (1) Definition of Viewing Angle :

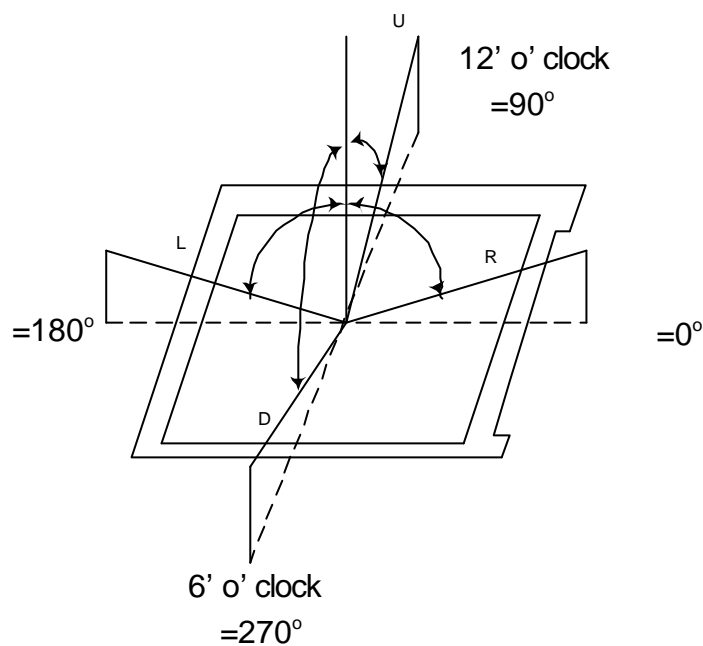

Note (2) Definition of Contrast Ratio(CR) :
measured at the center point of panel

$$CR = \frac{\text{Luminance with all pixels white}}{\text{Luminance with all pixels black}}$$

Document Title	HSD150MX49-A Product Information	Page No.	8 / 26
Document No.		Revision	1.0

Note (3) Definition of Response Time : Sum of T_R and T_F

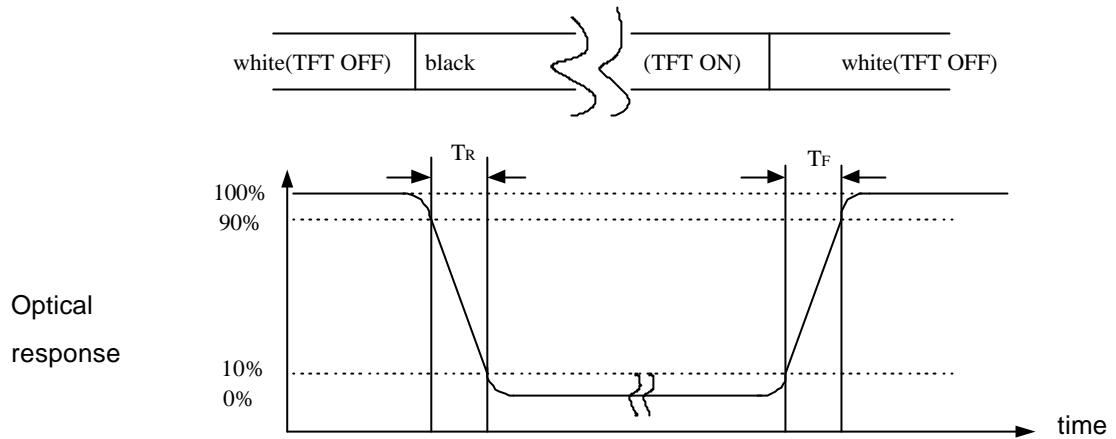

Note (4) Definition of brightness uniformity

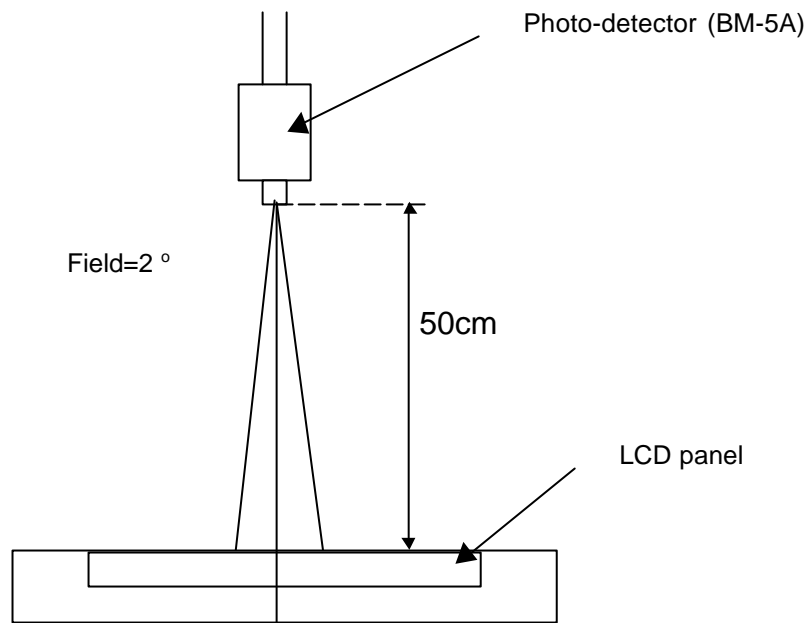

Document Title	HSD150MX49-A Product Information	Page No.	9 / 26
Document No.		Revision	1.0

Note (5) Definition of brightness uniformity

$$\text{Luminance uniformity} = (\text{Min Luminance of 9 points}) / (\text{Max Luminance of 9 points}) \times 100\%$$

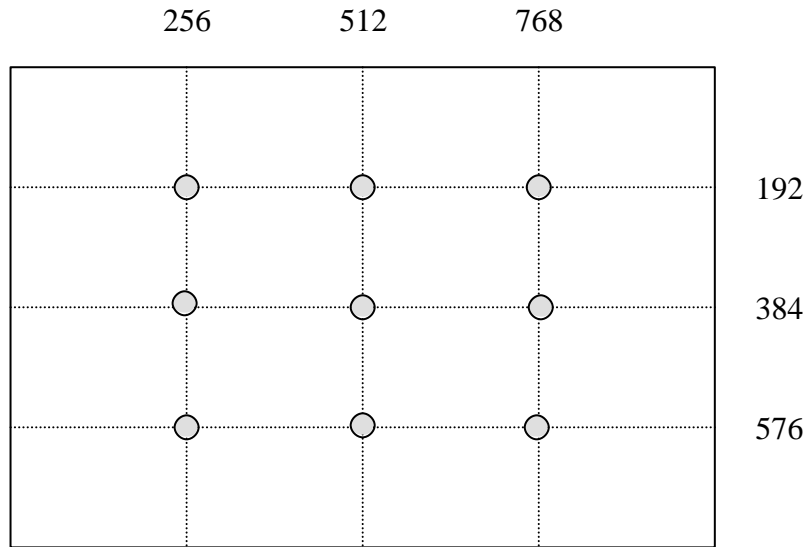

Document Title	HSD150MX49-A Product Information	Page No.	10 / 26
Document No.		Revision	1.0

Note (6) Definition of crosstalk CT(1) ~ CT(4)

$$CT(n) = \frac{|L(n) - LB(n)|}{L(n)} \times 100\% , n = 1 \sim 4$$

Where L(n) = Luminance of point “n” at pattern A (cd/m²) , n=1 ~ 4

LB(n) = Luminance of point “n” at pattern B (cd/m²) , n=1 ~ 4

The location measured will be exactly the same in both patterns.

L0 : Luminance with all pixels black

L255:Luminance with all pixels white

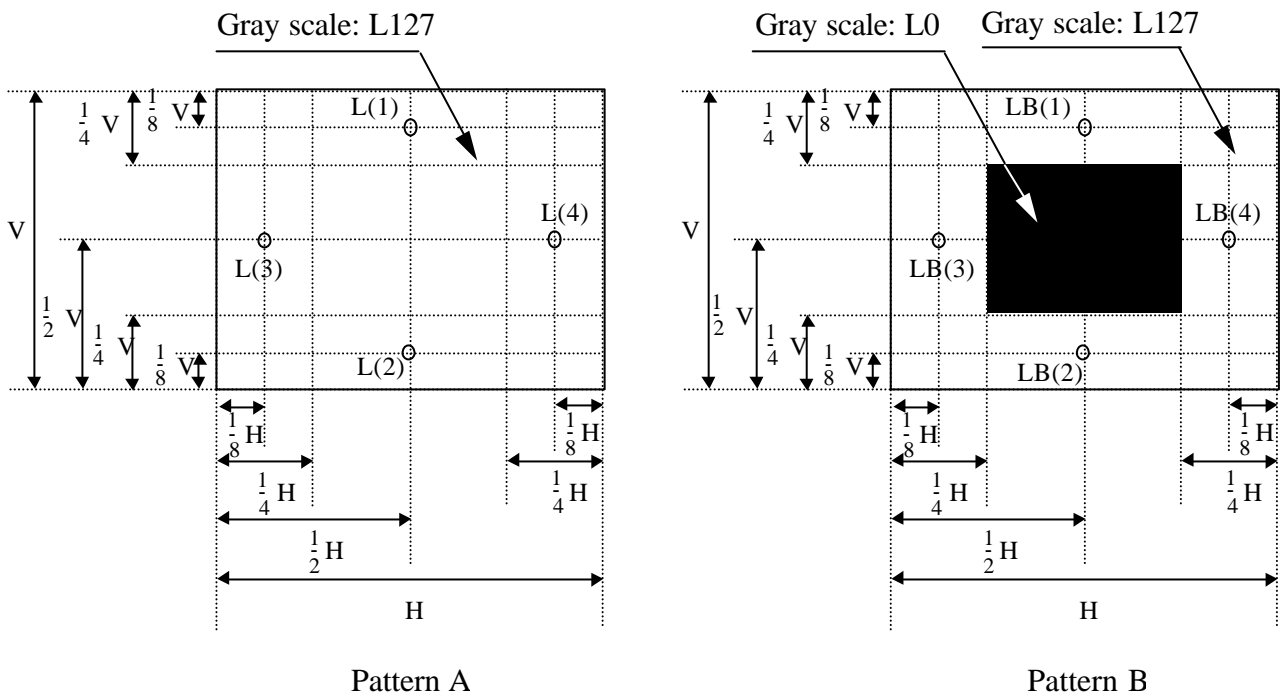

Document Title	HSD150MX49-A Product Information	Page No.	11 / 26
Document No.		Revision	1.0

4.0 ELECTRICAL CHARACTERISTICS

4.1 TFT LCD Module

Item	Symbol	Min.	Typ.	Max.	Unit	Note
Voltage of power supply	V_{DD}	3.0	3.3	3.6	V	
Input voltage	High	V_{IH}	--	3.6	V	
	Low	V_{IL}	0	--	0.9	V
Current of power supply	Mosaic	I_{DD}	--	TBD	mA	(1)
Vsync frequency	f_V	--	60.00	75.00	Hz	(2)
Hsync frequency	f_H	--	48.35	60.00	KHz	
Main frequency	f_{DCLK}	--	32.50	39.37	MHz	

Note (1) Mosaic: Dot checker image

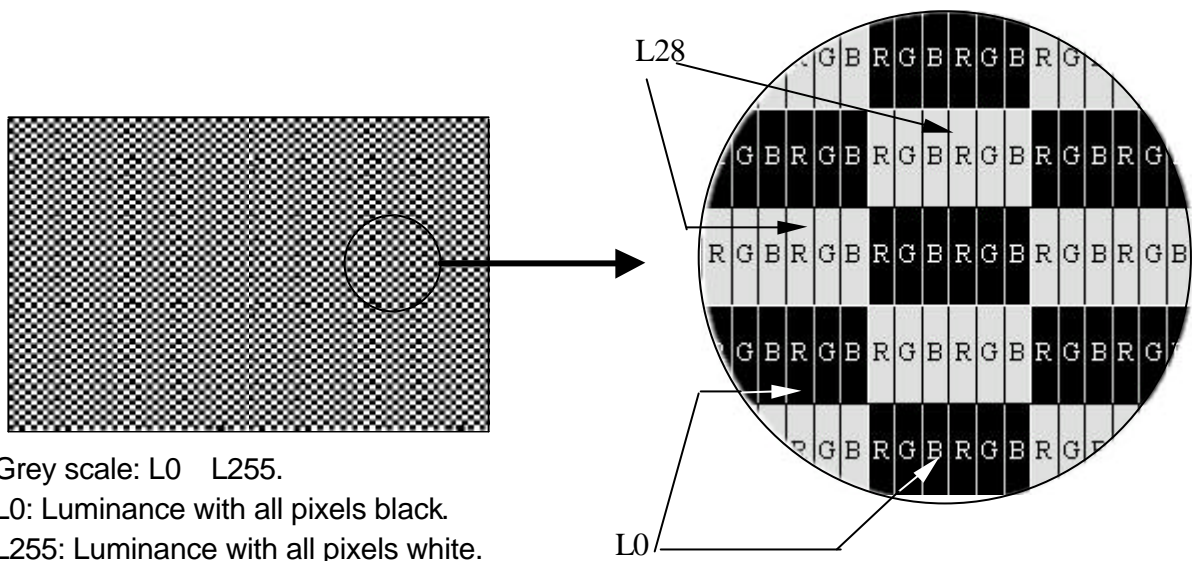

Note (2) When f_V is too low, a flicker may be occurred on the display.

Document Title	HSD150MX49-A Product Information	Page No.	12 / 26
Document No.		Revision	1.0

4.2 Back-Light Unit

The back-light system is an top & bottom edge-lighting type with 2 CCFL(Cold Cathode Fluorescent Lamp). The characteristics of two lamps are shown in the following tables.

Item	Symbol	Min.	Typ.	Max.	Unit	Note
Lamp current	IL	3.0	6.0	7.0	mA(rms)	(1)
Lamp voltage	VL	--	TBD	--	V(rms)	$I_L=6.0mA$
Frequency	fL	30	50	80	KHz	(2)
Operating life time	Hr	30,000	--	--	Hour	(3)
Startup voltage	Vs	--	--	TBD	V(rms)	at 25°C
				TBD		at 0°C

Note (1) Lamp current is measured with current meter for high frequency as shown below. Specified valued are for a lamp.

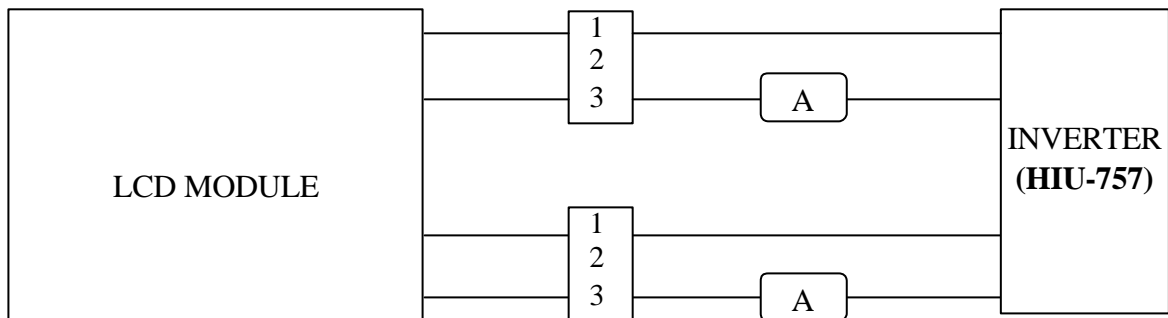

Note (2) Lamp frequency may produce interference with horizontal synchronous frequency and this may cause line flow on the display. Therefore lamp frequency shall be detached from the horizontal synchronous frequency and its harmonics as far as possible in order to avoid interference.

Note (3) Life time (Hr) can be defined as the time in which it continues to operate under the condition : $T_a=25\pm 3^\circ C$, $I_L=6.0mA(rms)$ and $f_L=50kHz$ until one of the following event occurs :

1. When the brightness becomes 50%
2. When the startup voltage(Vs) at 0°C becomes higher than the maximal Value of Vs specified above.

Note (4) Max. startup voltage shall be defined as max. voltage which CCFL can be startup. When the customer select the inverter, the min. value of startup voltage must be higher than CCFL's max. startup voltage.

Document Title	HSD150MX49-A Product Information	Page No.	13 / 26
Document No.		Revision	1.0

5.0 BLOCK DIAGRAM
5.1 TFT LCD Module

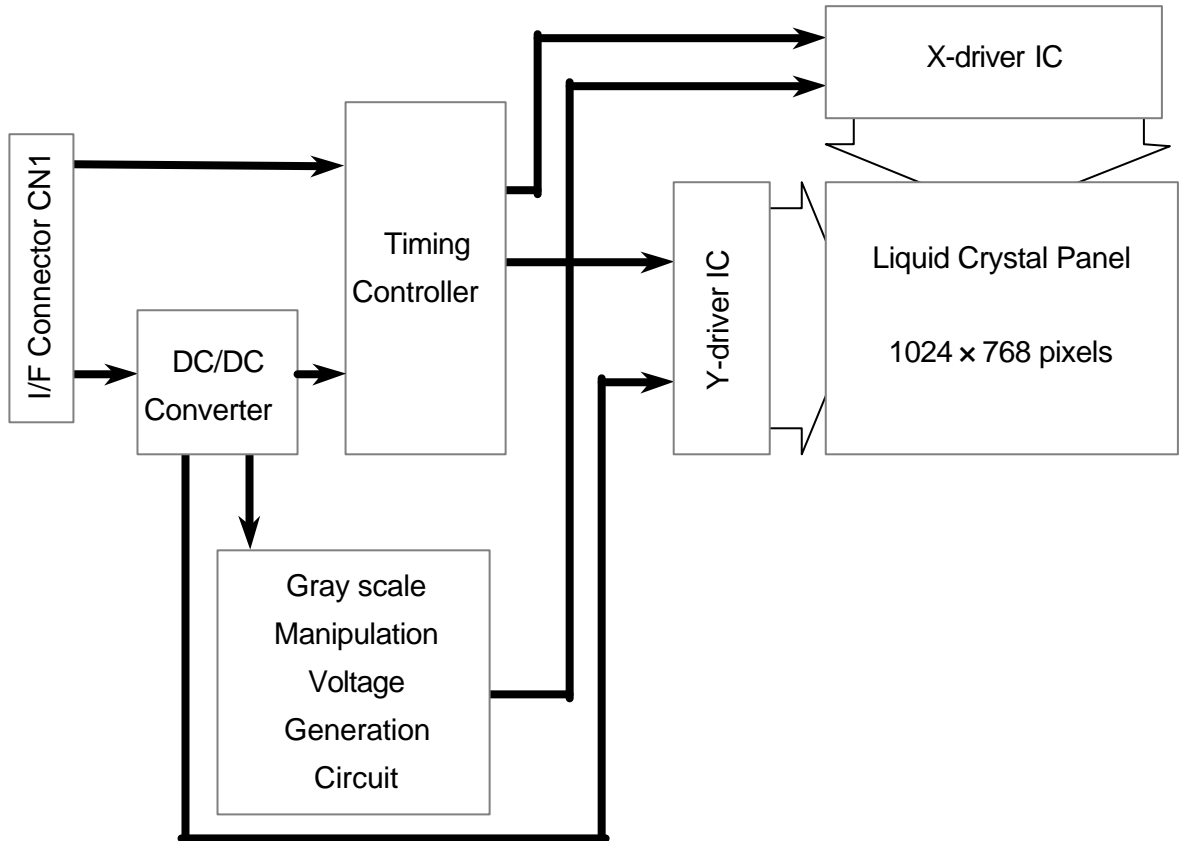

5.2 Back Light Unit

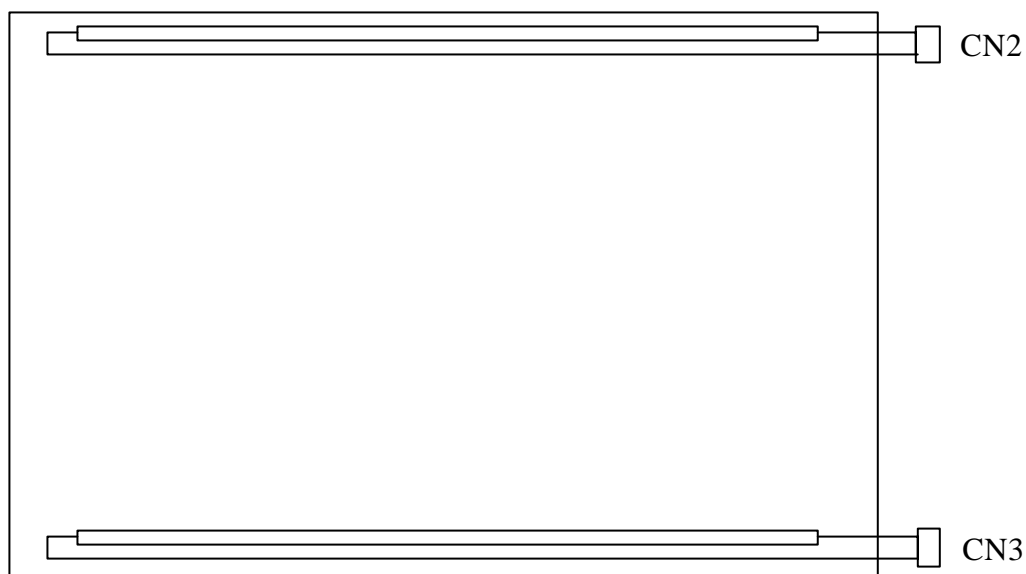

Document Title	HSD150MX49-A Product Information	Page No.	14 / 26
Document No.		Revision	1.0

6.0 INTERFACE PIN CONNECTION

6.1 TFT LCD Module

CN1¹⁾²⁾³⁾ INPUT SIGNAL (802RVS-080005R / HANNSTAR ELECTRONICS CO.)^{1) 2) 3)}

MATING CONNECTOR: 802PVS-080405R-M / HANNSTAR ELECTRONICS CO.)

Terminal no.	Symbol	Function	Terminal No.	Symbol	Function
1	GND	Ground	41	GND	Ground
2	OR0	RED DATA R0 (LSB) ODD	42	EG0	GREEN DATA G0 (LSB) EVEN
3	OR1	RED DATA R1 ODD	43	EG1	GREEN DATA G1 EVEN
4	OR2	RED DATA R2 ODD	44	EG2	GREEN DATA G2 EVEN
5	OR3	RED DATA R3 ODD	45	EG3	GREEN DATA G3 EVEN
6	GND	Ground	46	GND	Ground
7	OR4	RED DATA R4 ODD	47	EG4	GREEN DATA G4 EVEN
8	OR5	RED DATA R5 ODD	48	EG5	GREEN DATA G5 EVEN
9	OR6	RED DATA R6 ODD	49	EG6	GREEN DATA G6 EVEN
10	OR7	RED DATA R7 (MSB) ODD	50	EG7	GREEN DATA G7 (MSB) EVEN
11	GND	Ground	51	GND	Ground
12	OG0	GREEN DATA G0 (LSB) ODD	52	EB0	BLUE DATA B0 (LSB) EVEN
13	OG1	GREEN DATA G1 ODD	53	EB1	BLUE DATA B1 EVEN
14	OG2	GREEN DATA G2 ODD	54	EB2	BLUE DATA B2 EVEN
15	OG3	GREEN DATA G3 ODD	55	EB3	BLUE DATA B3 EVEN
16	GND	Ground	56	GND	Ground
17	OG4	GREEN DATA G4 ODD	57	EB4	BLUE DATA B4 EVEN
18	OG5	GREEN DATA G5 ODD	58	EB5	BLUE DATA B5 EVEN
19	OG6	GREEN DATA G6 ODD	59	EB6	BLUE DATA B6 EVEN
20	OG7	GREEN DATA G7 (MSB) ODD	60	EB7	BLUE DATA B7 (MSB) EVEN
21	GND	Ground	61	GND	Ground
22	OB0	BLUE DATA B0 (LSB) ODD	62	GND	Ground
23	OB1	BLUE DATA B1 ODD	63	CLK	PIXEL CLOCK
24	OB2	BLUE DATA B2 ODD	64	GND	Ground
25	OB3	BLUE DATA B3 ODD	65	GND	Ground
26	GND	Ground	66	HSYNC	Horizontal synchronization signal
27	OB4	BLUE DATA B4 ODD	67	GND	Ground
28	OB5	BLUE DATA B5 ODD	68	GND	Ground
29	OB6	BLUE DATA B6 ODD	69	ENAB	DATA ENABLE
30	OB7	BLUE DATA B7 (MSB) ODD	70	VSYNC	Vertical synchronization signal
31	GND	Ground	71	VDD	3.3 V POWER SUPPLY
32	ER0	RED DATA R0 (LSB) EVEN	72	VDD	3.3 V POWER SUPPLY
33	ER1	RED DATA R1 EVEN	73	VDD	3.3 V POWER SUPPLY
34	ER2	RED DATA R2 EVEN	74	VDD	3.3 V POWER SUPPLY
35	ER3	RED DATA R3 EVEN	75	VDD	3.3 V POWER SUPPLY
36	GND	Ground	76	NC	No Connection
37	ER4	RED DATA R4 EVEN	77	PTRN	No Connection
38	ER5	RED DATA R5 EVEN	78	MLCNG1	No Connection
39	ER6	RED DATA R6 EVEN	79	FRC	No Connection
40	ER7	RED DATA R7 (MSB) EVEN	80	GND	Ground

Note 1) Please connect NC pin to nothing. Don't connect it to ground nor to other signal input. (NC pin should be open.)

Note 2) Please connect GND pin to ground. Don't use it as no-connect nor connect with high impedance.

Note 3) 16.7 million colors are displayed by the combinations of 24 bits data.

Document Title	HSD150MX49-A Product Information	Page No.	15 / 26
Document No.		Revision	1.0

6.2 Back-Light Unit

CN2¹⁾ CCFL Power Source (BHR-03VS-1/Japan Solderless Terminal MFG Co., LTD)

Mating Connector : SM02 (8.0) B-BHS/Japan Solderless Terminal MFG Co., LTD)

Terminal no.	Symbol	Function
1	VL1	CCFL power supply (high voltage)
2	NC ¹⁾	
3	GL1	CCFL power supply (low voltage)

CN3¹⁾ CCFL Power Source (BHR-03VS-1/Japan Solderless Terminal MFG Co., LTD)

Mating Connector : SM02 (8.0) B-BHS/Japan Solderless Terminal MFG Co., LTD)

Terminal no.	Symbol	Function
1	VL2	CCFL power supply (high voltage)
2	NC ¹⁾	
3	GL2	CCFL power supply (low voltage)

Note 1) Please connect NC pin to nothing. Don't connect it to ground nor to other signal Input. (NC pin should be open.)

Document Title	HSD150MX49-A Product Information	Page No.	16 / 26
Document No.		Revision	1.0

6.3 Relationship Between Displayed Color and Input

Display	MSB				LSB				MSB				LSB				MSB				LSB				Gray scale level		
	R7	R6	R5	R4	R3	R2	R1	R0	G7	G6	G5	G4	G3	G2	G1	G0	B7	B6	B5	B4	B3	B2	B1	B0			
Basic color	Black	L	L	L	L	L	L	L	L	L	L	L	L	L	L	L	L	L	L	L	L	L	L	L	L	-	
	Blue	L	L	L	L	L	L	L	L	L	L	L	L	L	L	L	L	H	H	H	H	H	H	H	H	-	
	Green	L	L	L	L	L	L	L	L	H	H	H	H	H	H	H	H	L	L	L	L	L	L	L	L	-	
	Light Blue	L	L	L	L	L	L	L	L	H	H	H	H	H	H	H	H	H	H	H	H	H	H	H	H	-	
	Red	H	H	H	H	H	H	H	H	L	L	L	L	L	L	L	L	L	L	L	L	L	L	L	L	-	
	Purple	H	H	H	H	H	H	H	H	L	L	L	L	L	L	L	L	H	H	H	H	H	H	H	H	-	
	Yellow	H	H	H	H	H	H	H	H	H	H	H	H	H	H	H	H	L	L	L	L	L	L	L	L	-	
White	H	H	H	H	H	H	H	H	H	H	H	H	H	H	H	H	H	H	H	H	H	H	H	H	-		
Gray scale of Red	Black	L	L	L	L	L	L	L	L	L	L	L	L	L	L	L	L	L	L	L	L	L	L	L	L	L0	
	Dark	L	L	L	L	L	L	L	H	L	L	L	L	L	L	L	L	L	L	L	L	L	L	L	L	L1	
		L	L	L	L	L	L	H	L	L	L	L	L	L	L	L	L	L	L	L	L	L	L	L	L	L2	
		:	:	:	:	:	:	:	:	:	:	:	:	:	:	:	:	:	:	:	:	:	:	:	:	L3 L251	
	Light	H	H	H	H	H	L	H	H	L	L	L	L	L	L	L	L	L	L	L	L	L	L	L	L	L255	
		H	H	H	H	H	H	L	H	L	L	L	L	L	L	L	L	L	L	L	L	L	L	L	L	L255	
		H	H	H	H	H	H	H	L	L	L	L	L	L	L	L	L	L	L	L	L	L	L	L	L	L255	
Red	H	H	H	H	H	H	H	H	L	L	L	L	L	L	L	L	L	L	L	L	L	L	L	L	Red L255		
Gray scale of Green	Black	L	L	L	L	L	L	L	L	L	L	L	L	L	L	L	L	L	L	L	L	L	L	L	L	L0	
	Dark	L	L	L	L	L	L	L	L	L	L	L	L	L	L	H	L	L	L	L	L	L	L	L	L1		
		L	L	L	L	L	L	L	L	L	L	L	L	L	H	L	L	L	L	L	L	L	L	L	L2		
		:	:	:	:	:	:	:	:	:	:	:	:	:	:	:	:	:	:	:	:	:	:	:	L3 L251		
	Light	L	L	L	L	L	L	L	L	H	H	H	H	L	H	H	L	L	L	L	L	L	L	L	L255		
		L	L	L	L	L	L	L	L	H	H	H	H	H	L	H	L	L	L	L	L	L	L	L	L255		
		L	L	L	L	L	L	L	L	H	H	H	H	H	H	L	L	L	L	L	L	L	L	L	L255		
Green	L	L	L	L	L	L	L	L	H	H	H	H	H	H	H	L	L	L	L	L	L	L	L	Green L255			
Gray scale of Blue	Black	L	L	L	L	L	L	L	L	L	L	L	L	L	L	L	L	L	L	L	L	L	L	L	L	L0	
	Dark	L	L	L	L	L	L	L	L	L	L	L	L	L	L	L	L	L	L	L	L	L	L	L	H	L1	
		L	L	L	L	L	L	L	L	L	L	L	L	L	L	L	L	L	L	L	L	L	L	H	L	L2	
		:	:	:	:	:	:	:	:	:	:	:	:	:	:	:	:	:	:	:	:	:	:	:	L3 L251		
	Light	L	L	L	L	L	L	L	L	L	L	L	L	L	L	L	L	H	H	H	H	L	H	H	H	L255	
		L	L	L	L	L	L	L	L	L	L	L	L	L	L	L	L	H	H	H	H	H	L	H	H	L255	
		L	L	L	L	L	L	L	L	L	L	L	L	L	L	L	L	H	H	H	H	H	H	L	H	L255	
Blue	L	L	L	L	L	L	L	L	L	L	L	L	L	L	L	L	H	H	H	H	H	H	H	H	Blue L255		
Gray scale of White & Black	Black	L	L	L	L	L	L	L	L	L	L	L	L	L	L	L	L	L	L	L	L	L	L	L	L	L0	
	Dark	L	L	L	L	L	L	H	L	L	L	L	L	H	L	L	L	L	L	L	H	L	L	L	L	L	L1
		L	L	L	L	L	L	H	L	L	L	L	L	H	L	L	L	L	L	H	L	L	L	L	L	L2	
		:	:	:	:	:	:	:	:	:	:	:	:	:	:	:	:	:	:	:	:	:	:	:	:	L3 L251	
	Light	H	H	H	H	L	H	H	H	H	H	H	L	H	H	H	H	H	H	L	H	H	H	H	L255		
		H	H	H	H	H	L	H	H	H	H	H	H	L	H	H	H	H	H	H	L	H	H	H	L255		
		H	H	H	H	H	H	L	H	H	H	H	H	L	H	H	H	H	H	L	H	H	H	H	L255		
White	H	H	H	H	H	H	H	H	H	H	H	H	H	H	H	H	H	H	H	H	H	H	H	White L255			

Document Title	HSD150MX49-A Product Information	Page No.	17 / 26
Document No.		Revision	1.0

6.4 Pixel Format

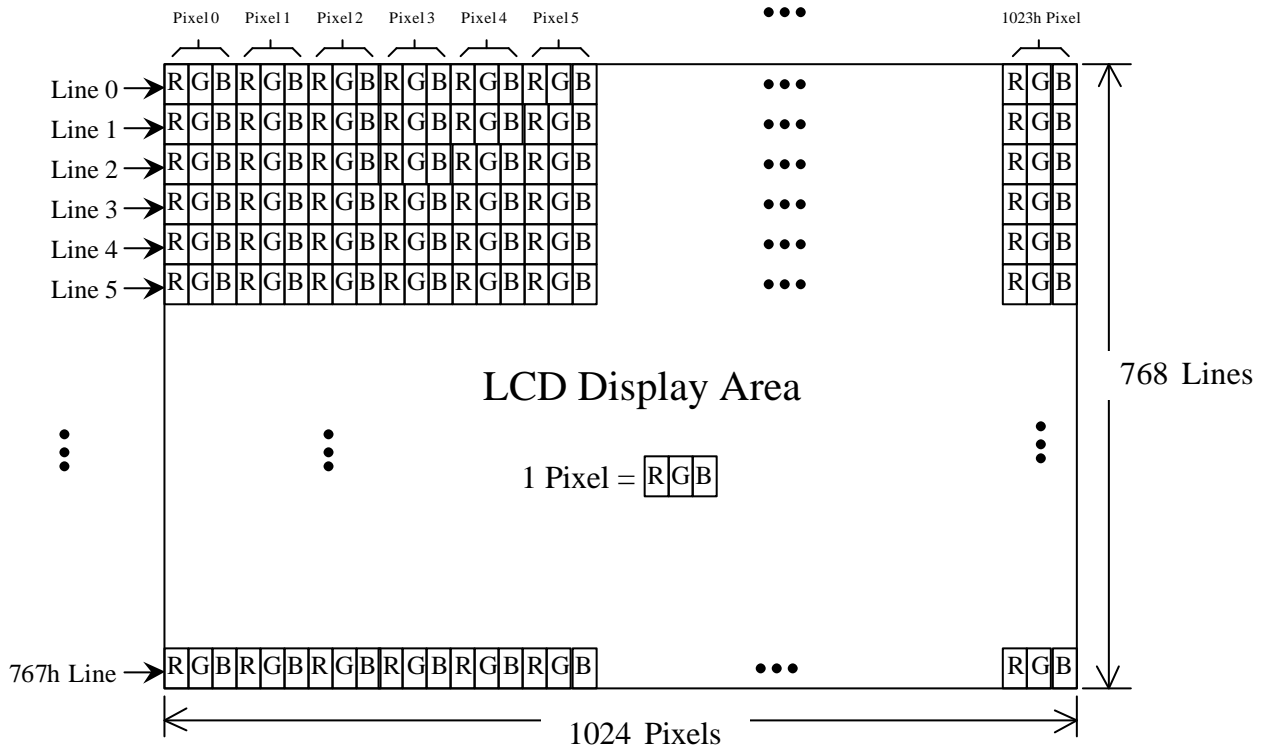

Note: The first pixel is even pixel.

Document Title	HSD150MX49-A Product Information	Page No.	18 / 26
Document No.		Revision	1.0

7.0 INTERFACE TIMING ¹⁾²⁾³⁾⁴⁾⁵⁾⁶⁾

7.1 Timing Parameters (Hsync, Vsync and DE mode)

Item	Symbol	Min.	Typ.	Max.	Unit	Remarks
Vertical display term	Period	t1	778×t4 -	806×t4 16.67	860×t4 -	- ms 1) 5)
	Active	t2	-	768×t4 15.88	-	- ms 1)
	Display start	t3	4×t4 -	-	256×t4 -	- ms 1)
Horizontal display term	Period	t4	590×t7 -	672×t7 20.68	700×t7 -	- μs 1) 5)
	Active	t5	-	512×t7 15.76	-	- μs 1)
	Display Start	t6	16×t7 -	-	512×t7 -	- μs 1)
Clock	Period	t7	25.00	30.77	-	ns 5)
	Low time	t8	9	-	-	ns
	High time	t9	9	-	-	ns
Data	Setup time	t10	2	-	-	ns
	Hold time	t11	5	-	-	ns

Note 1) Refer to TIMING CHART at page18, 19 and 20.

Note 2) In case of using the long frame period, the deterioration of display quality, noise etc. may be occurred.

Note 3) When ENAB is fixed to “L” level after NCLK input, the panel is displayed as black. However, a flicker may be occurred on the display. When ENAB is fixed to “H” level after NCLK input, the panel will be damaged.

Note 4) Do not fix NCLK to “H” or “L” level while the V_{DD} (+3.3V) is supplied. If NCLK is fixed to “H” level or “L” level for certain period while the V_{DD} (+3.3V) is supplied, the panel may be damaged.

Note 5) Do not change t1 and t4 values in the operation. When t1 or t4 is changed, the panel is displayed as black.

Note 6) Please adjust LCD operating signal timing and FL driving frequency, to optimize the display quality. There is a possibility that flicker is observed by the interference of LCD operating signal timing and FL driving condition (especially driving frequency).

Note 7) Input vertical display term quantity should be $2+768 = 770$ lines

Document Title	HSD150MX49-A Product Information	Page No.	19 / 26
Document No.		Revision	1.0

7.2 Timing Diagram of Interface Signal (Hsync, Vsync and DE mode)

24 Bit two pixel/clock input mode

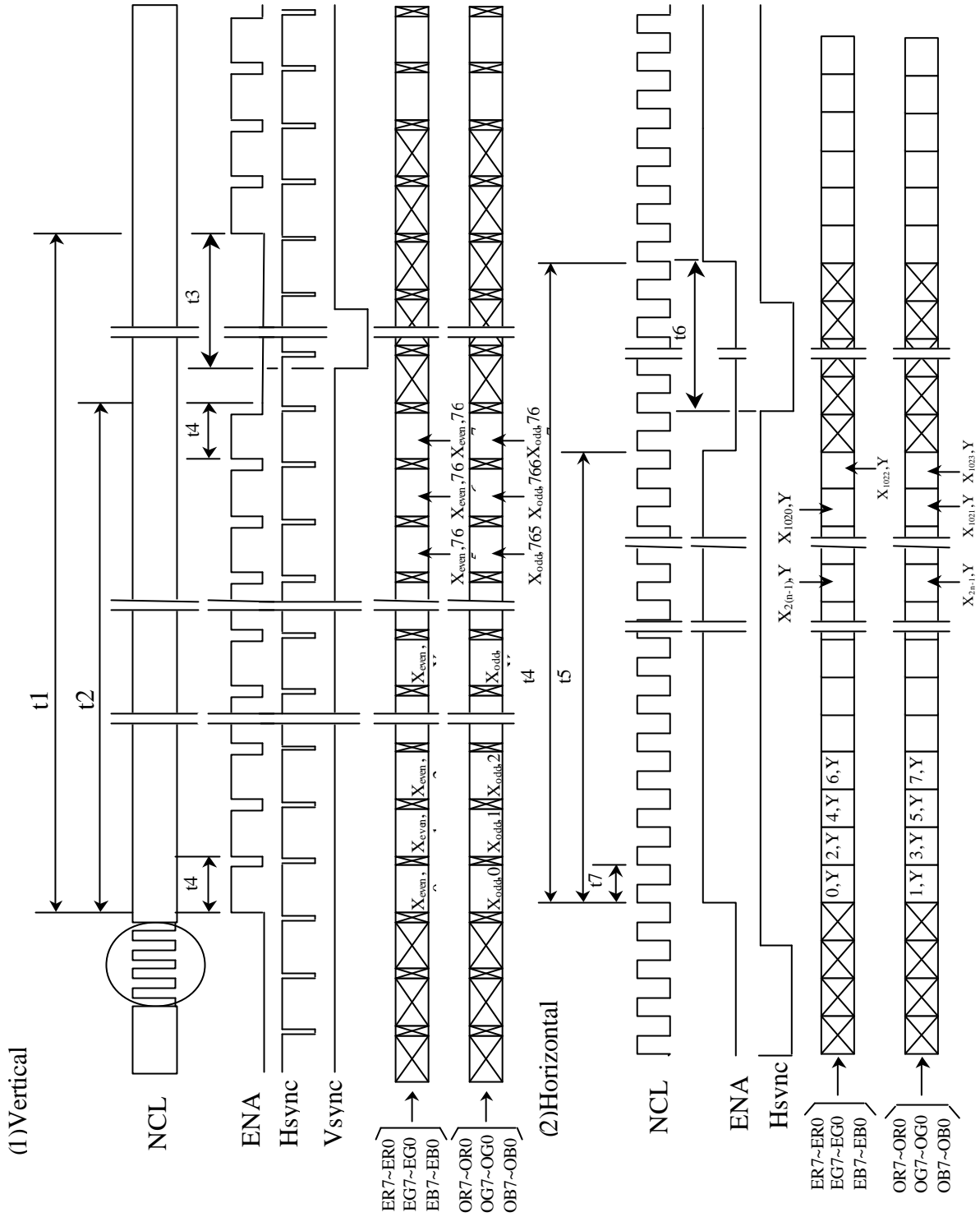

Document Title	HSD150MX49-A Product Information	Page No.	20 / 26
Document No.		Revision	1.0

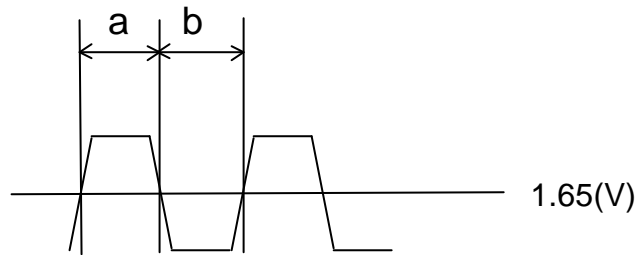

Duty(a,b) : 50±10%

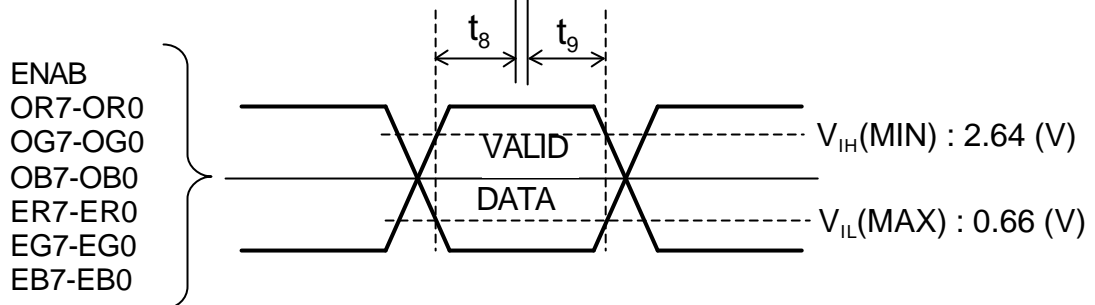
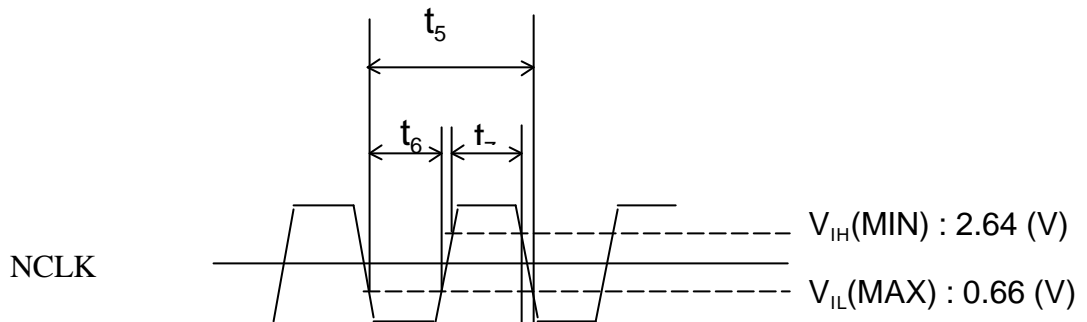

Document Title	HSD150MX49-A Product Information	Page No.	21 / 26
Document No.		Revision	1.0

7.3 Power ON/OFF Sequence

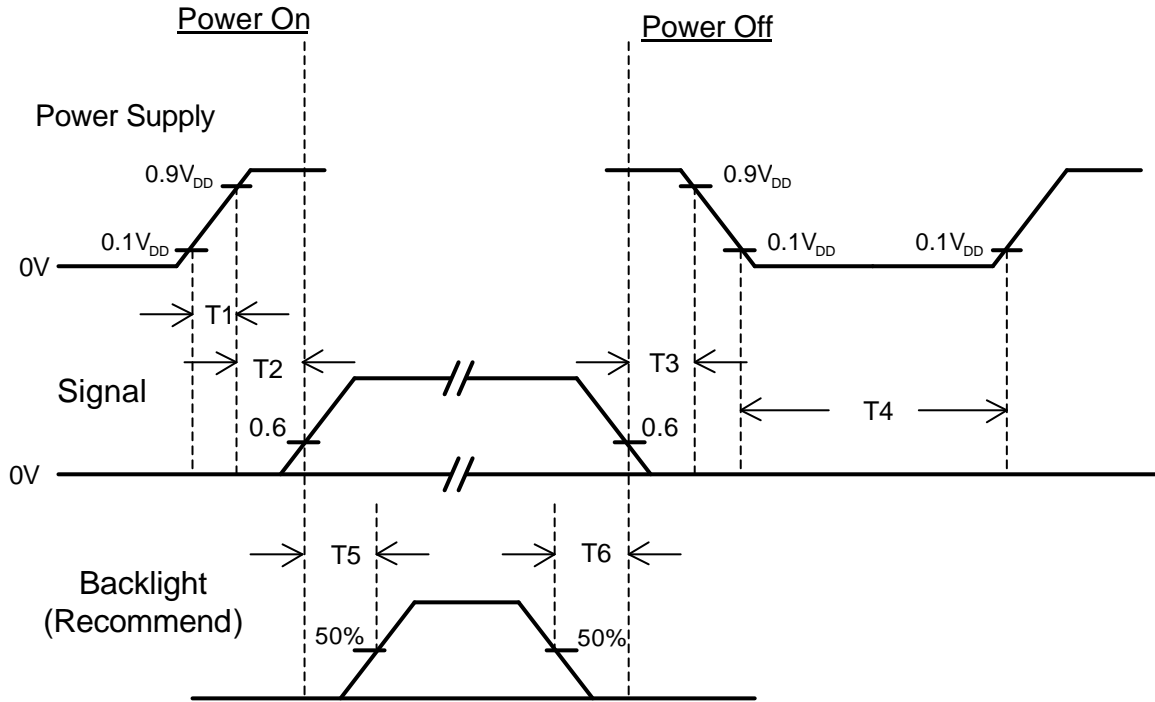

Item	Min.	Typ.	Max.	Unit	Remark
T1	0	-	10	msec	
T2	0	-	50	msec	
T3	0	-	50	msec	
T4	1	-	-	sec	
T5	200	-	-	msec	
T6	200	-	-	msec	

Note (1) The supply voltage of the external system for the module input should be the same as the definition of V_{DD}.

(2) Apply the lamp voltage within the LCD operation range. When the back-light turns on before the LCD operation or the LCD turns off before the back-light turns off, the display may momentarily become white.

(3) In case of V_{DD} = off level, please keep the level of input signal on the low or keep a high impedance.

(4) T4 should be measured after the module has been fully discharged between power off and on period.

(5) Interface signal shall not be kept at high impedance when the power is on.

Document Title	HSD150MX49-A Product Information	Page No.	22 / 26
Document No.		Revision	1.0

8.0 OUTLINE DIMENSION

8.1 Front View Outline Dimension

Unit : mm

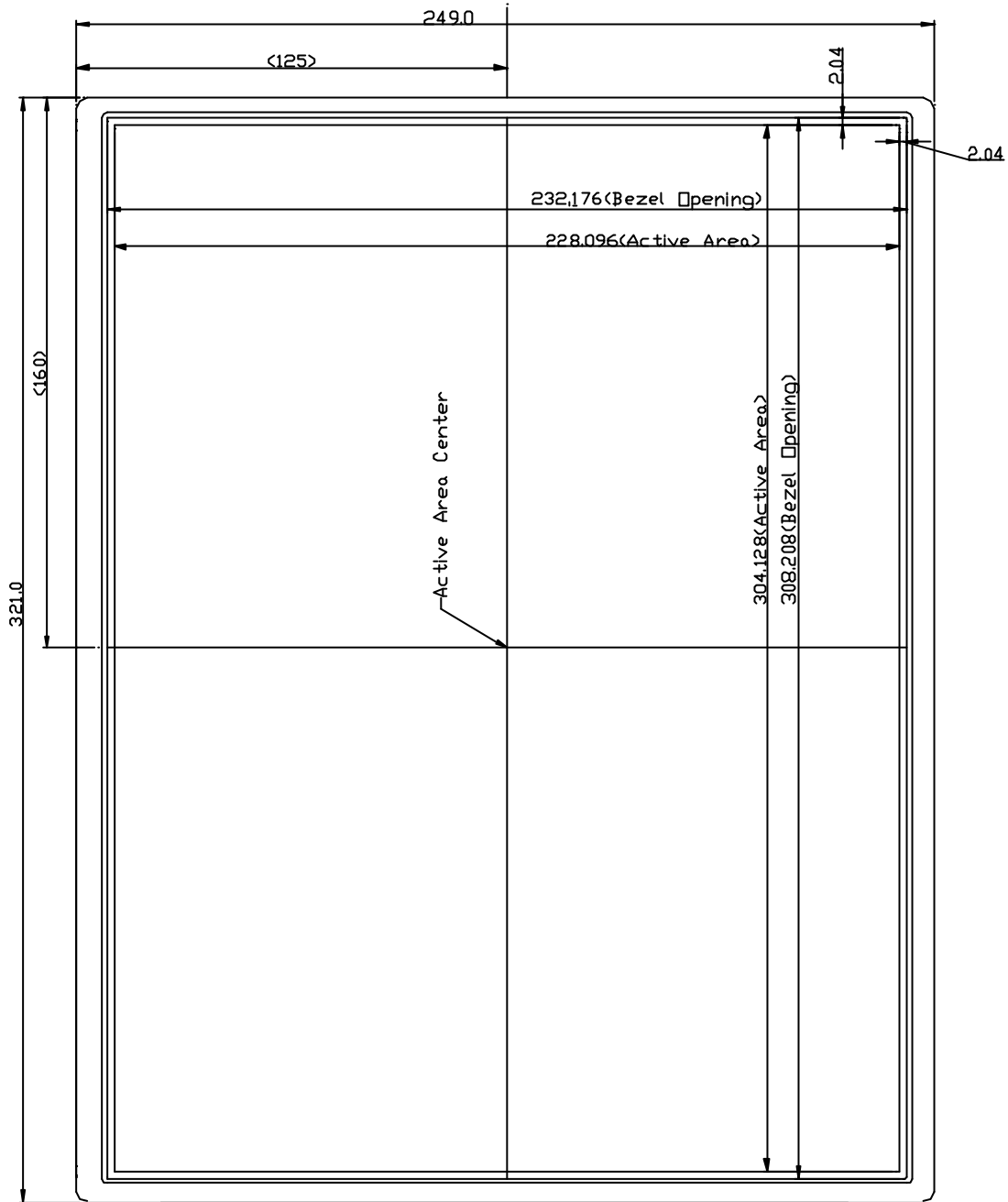

Document Title	HSD150MX49-A Product Information	Page No.	23 / 26
Document No.		Revision	1.0

8.2 Back View Outline Dimension

Unit : mm

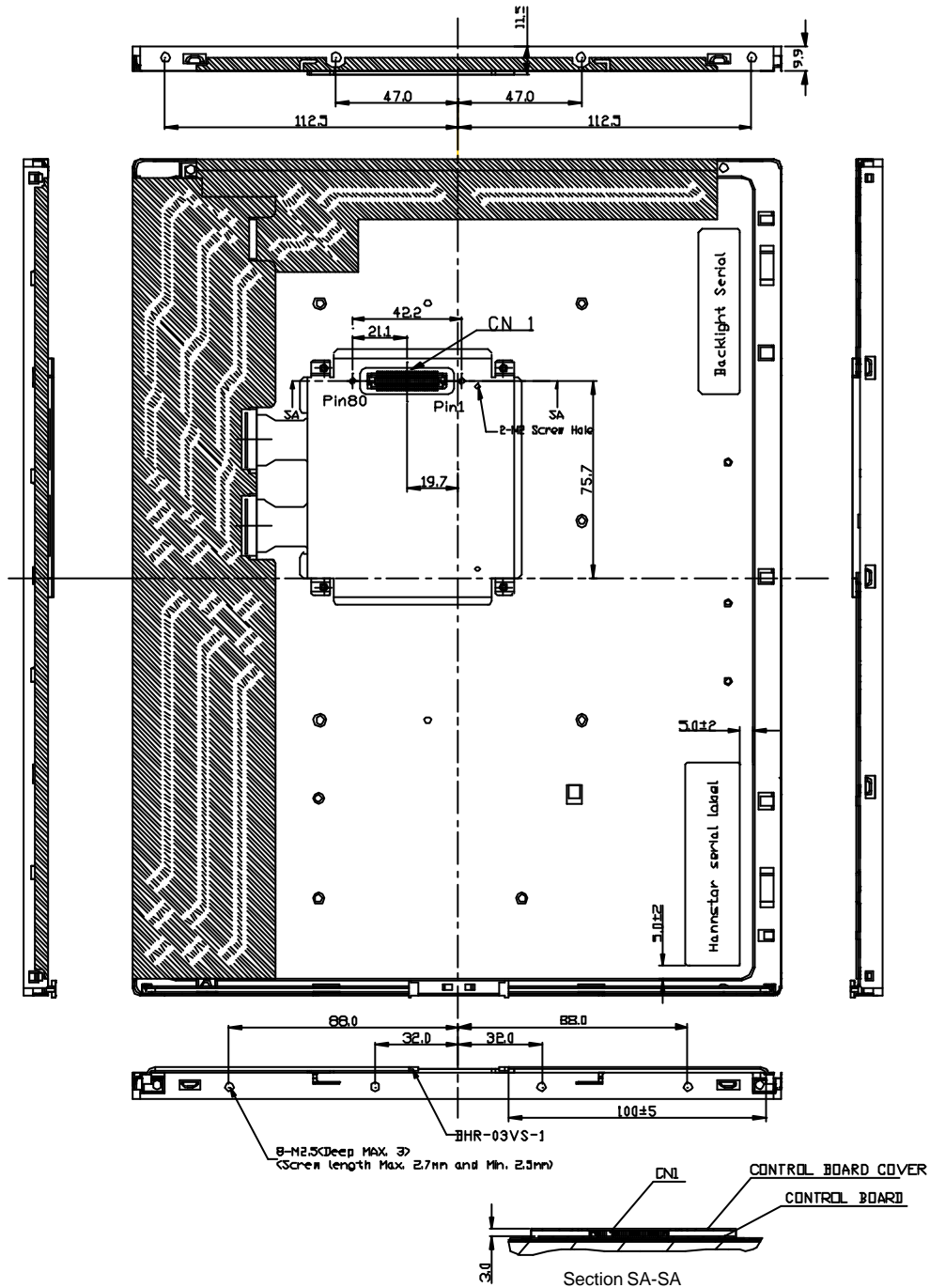

Note:

1. UNSPECIFIED DIMENSIONAL TOLERANCE ARE $\pm 0.5\text{mm}$
2. CN1 CONNECTOR: 802RVS-080005R(HANNSTAR ELECTRONICS CO.)
3. CN1 CONNECTOR FIXED SCREW LENGTH PLEASE REFERENCE SECTION SA-SA.

Document Title	HSD150MX49-A Product Information	Page No.	24 / 26
Document No.		Revision	1.0

9.0 LOT MARK

9.1 Lot Mark

1	2	3	4	5	6	7	8	9	10	11	12	13	14	15
---	---	---	---	---	---	---	---	---	----	----	----	----	----	----

code 1,2,3,4,5,6: HannStar internal flow control code.

code 7: production location.

code 8: production year.

code 9: production month.

code 10,11,12,13,14,15: serial number.

Note (1) Production Year

Year	1999	2000	2001	2002	2003	2004	2005	2006	2007	2008
Mark	9	0	1	2	3	4	5	6	7	8

Note (2) Production Month

Month	Jan.	Feb.	Mar.	Apr.	May.	Jun.	Jul.	Aug.	Sep.	Oct.	Nov.	Dec.
Mark	1	2	3	4	5	6	7	8	9	A	B	C

9.2 Location of Lot Mark

(1) The label is attached to the backside of the LCD module.

(2) This is subject to change without prior notice.



Lot mark

Document Title	HSD150MX49-A Product Information	Page No.	25 / 26
Document No.		Revision	1.0

10.0 GENERAL PRECAUTION

10.1 Use Restriction

This product is not authorized for use in life supporting systems, aircraft navigation control systems, military systems and any other application where performance failure could be life-threatening or otherwise catastrophic.

10.2 Disassembling or Modification

Do not disassemble or modify the module. It may damage sensitive parts inside LCD module, and may cause scratches or dust on the display. HannStar does not warrant the module, if customers disassemble or modify the module.

10.3 Breakage of LCD Panel

10.3.1 If LCD panel is broken and liquid crystal spills out, do not ingest or inhale liquid crystal, and do not contact liquid crystal with skin.

10.3.2 If liquid crystal contacts mouth or eyes, rinse out with water immediately.

10.3.3 If liquid crystal contacts skin or cloths, wash it off immediately with alcohol and rinse thoroughly with water.

10.3.4 Handle carefully with chips of glass that may cause injury, when the glass is broken.

10.4 Electric Shock

10.4.1 Disconnect power supply before handling LCD module.

10.4.2 Do not pull or fold the CCFL cable.

10.4.3 Do not touch the parts inside LCD modules and the fluorescent lamp's connector or cables in order to prevent electric shock.

10.5 Absolute Maximum Ratings and Power Protection Circuit

10.5.1 Do not exceed the absolute maximum rating values, such as the supply voltage variation, input voltage variation, variation in parts' parameters, environmental temperature, etc., otherwise LCD module may be damaged.

10.5.2 Please do not leave LCD module in the environment of high humidity and high temperature for a long time.

10.5.3 It's recommended to employ protection circuit for power supply.

10.6 Operation

10.6.1 Do not touch, push or rub the polarizer with anything harder than HB pencil lead.

10.6.2 Use fingerstalls of soft gloves in order to keep clean display quality, when persons handle the LCD module for incoming inspection or assembly.

10.6.3 When the surface is dusty, please wipe gently with absorbent cotton or other soft material.

Document Title	HSD150MX49-A Product Information	Page No.	26 / 26
Document No.		Revision	1.0

10.6.4 Wipe off saliva or water drops as soon as possible. If saliva or water drops contact with polarizer for a long time, they may causes deformation or color fading.

10.6.5 When cleaning the adhesives, please use absorbent cotton wetted with a little petroleum benzine or other adequate solvent.

10.7 Mechanism

Please mount LCD module by using mouting holes arranged in four corners tightly.

10.8 Static Electricity

10.8.1 Protection film must remove very slowly from the surface of LCD module to prevent from electrostatic occurrence.

10.8.2 Because LCD module use CMOS-IC on circuit board and TFT-LCD panel, it is very weak to electrostatic discharge. Please be careful with electrostatic discharge. Persons who handle the module should be grounded through adequate methods.

10.9 Strong Light Exposure

The module shall not be exposed under strong light such as direct sunlight. Otherwise, display characteristics may be changed.

10.10 Disposal

When disposing LCD module, obey the local environmental regulations.