



Product Information

Customer : Kortek

ISSUED DATE : Mar. 12, 2009

SAMSUNG TFT-LCD
MODEL : LTA400HF05

The Information Described in this Specification is Preliminary and can be changed without prior notice

NOTE :

LCD Business

Samsung Electronics Co . , LTD.

MODEL	LTA400HF05	Doc. No	06-000-G-090312	Page	1 / 29
-------	------------	---------	-----------------	------	--------

Contents

General Description	(3)
General Information	(3)
1. Absolute Maximum Ratings	(4)
1.1 Back Light Unit Absolute Maximum Ratings	
1.2 LED Unit Absolute Maximum Ratings	
2. Optical Characteristics	(6)
3. Electrical Characteristics	(9)
3.1 TFT LCD Module	
3.2 Back Light Unit	
3.3 LED LIPS Condition & Specification	
3.4 LED LIPS Output Specification	
4. Block Diagram	(12)
5. Input Terminal Pin Assignment	(13)
5.1 Input Signal & Power	
5.2 LED LIPS AC Input Pin Configuration	
5.3 LED LIPS Input & Output Pin Configuration	
5.4 LED LIPS Sequence	
5.5 LVDS Interface	
5.6 Input Signals, Basic Display Colors and Gray Scale of Each Color	
6. Interface Timing	(20)
6.1 Timing Parameters (DE only mode)	
6.2 Timing Diagrams of interface Signal (DE only mode)	
6.3 Power ON/OFF Sequence	
7. Outline Dimension	(23)
8. Packing	(25)
9. Marking & Others	(26)
10. General Precaution	(27)
10.1 Handling	
10.2 Storage	
10.3 Operation	
10.4 Operation Condition Guide	
10.5 Others	

MODEL

LTA400HF05

Doc. No

06-000-G-090312

Page

2 / 29

General Description

Description

LTA400HF05 is a color active matrix liquid crystal display (LCD) that uses amorphous silicon TFT (Thin Film Transistor) as switching components. This model is composed of a TFT LCD panel, a driver circuit and a back light unit.

The resolution of a 40.0" is 1920 x 1080 and this model can display up to 1.07 Billion colors with wide viewing angle of 89° or higher in all directions. This panel is intended to support applications to provide an excellent performance for Flat Panel Display such as Home-alone Multimedia TFT-LCD TV and High Definition TV.

Features

- RoHS compliance (Pb-free)
- High contrast & aperture ratio
- SPVA (Super Patterned Vertical Align) mode
- Wide viewing angle ($\pm 178^\circ$)
- High speed response (120Hz)
- FHD resolution (16:9)
- Low Power consumption
- White LED Backlight
- DE (Data Enable) mode
- LVDS (Low Voltage Differential Signaling) interface

General Information

Items	Specification	Unit	Note
Module Size	943.7(H _{TYP}) x 560.2(V _{TYP})	mm	± 1.0mm
	29.6(D _{MAX})		± 1.0mm
Weight	10,500 (Max.)	g	
Pixel Pitch	0.461(H) x 0.461(W)	mm	
Active Display Area	885.6(H) X 498.15(V)	mm	
Surface Treatment	Antiglare, Hard-coating(3H)	-	
Display Colors	10bit (FRC) – 1.07Billion	Colors	
Number of Pixels	1920 x 1080	Pixel	
Pixel Arrangement	RGB vertical stripe	-	
Display Mode	Normally Black	-	
Luminance of White	(450) Typ.	cd/m ²	

MODEL

LTA400HF05

Doc. No

06-000-G-090312

Page

3 / 29

1. Absolute Maximum Ratings

If the condition exceeds maximum ratings, it can cause malfunction or unrecoverable damage to the device.

1.1 Back Light Unit Absolute Maximum Ratings

Item	Symbol	Min.	Max.	Unit	Note
Power Supply Voltage	V_{DD}	GND-0.3	13	V	(1)
Storage temperature	T_{STG}	-20	60	°C	(2)
Glass surface temperature (Operation)	Center T_{OPR}	0	50	°C	(2)
Shock (non - operating)	S_{nop}	-	30	G	(3)
Vibration (non - operating)	V_{nop}	-	1.5	G	(4)

1.2 LED Unit Absolute Maximum Ratings

Item	Symbol	Max.	Unit	Note
Operating Temperature Range	T_{op}	-20~+70	°C	-
Storage Temperature Range	T_{STG}	-30~+70	°C	-
Junction Temperature	T_j	125	°C	-
Forward Current	I_f	0.12	A	Continuous operation @String (2string /1Bar)
	I_{fp}	0.3	A	Duty 35% operation @String (2string /1Bar)
Forward Voltage	V_f	158	V	Continuous operation @String (24 LEDs / 1String)
	V_{fp}	175	V	Impulsive operation @String (24 LEDs / 1String)
Thermal Resistance, Junction to PCB	$R_{th,JS}$	<65K/W	K/W	-

MODEL

LTA400HF05

Doc. No

06-000-G-090312

Page

4 / 29

Note (1) $T_a = 25 \pm 2 \text{ }^\circ\text{C}$

(2) Temperature and relative humidity range are shown in the figure below.

a. 90 % RH Max. ($T_a \leq 39 \text{ }^\circ\text{C}$)

b. Relative Humidity is 90% or less. ($T_a > 39 \text{ }^\circ\text{C}$)

c. No condensation

(3) 11ms, sine wave, one time for $\pm X, \pm Y, \pm Z$ axis

(4) 10-300 Hz, Sweep rate 10min, 30min for X,Y,Z axis

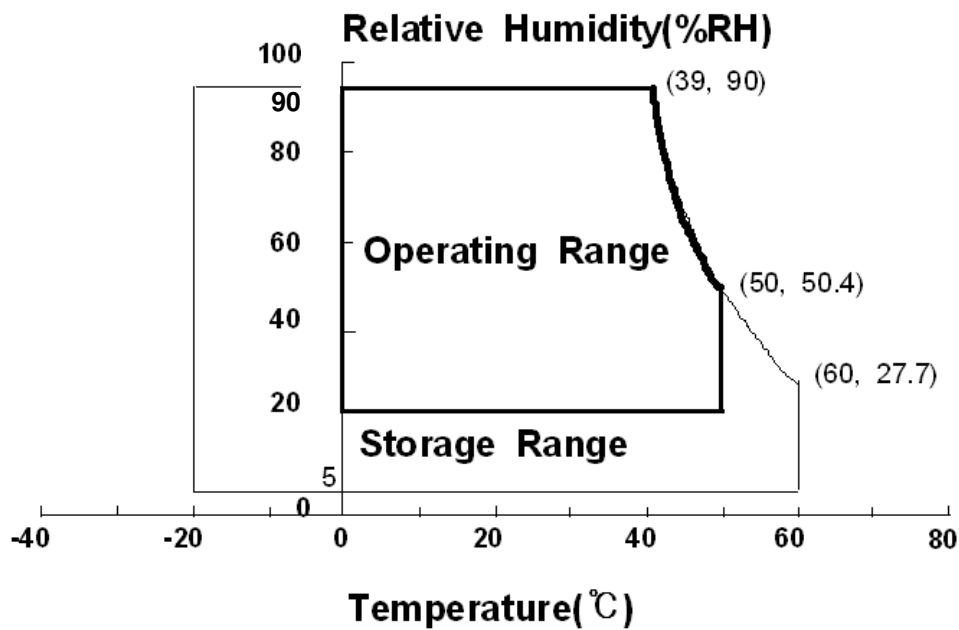

Fig. Temperature and Relative humidity range

2. Optical Characteristics

The optical characteristics should be measured in a dark room or equivalent.

Measuring equipment : TOPCON RD-80S, TOPCON SR-3 ,ELDIM EZ-Contrast

($T_a = 25 \pm 2^\circ\text{C}$, $V_{DD}=12.0\text{V}$, $f_v=120\text{Hz}$, $f_{DCLK}=297\text{MHz}$, LED current =90mA)

Item	Symbol	Condition	Min.	Typ.	Max.	Unit	Note	
Contrast Ratio (Center of screen)	C/R	Normal $\theta_{L,R}=0$ $\theta_{U,D}=0$ Viewing Angle	TBD	5,000	-	-	(1) SR-3	
Response Time	G-to-G		Tg	-	6	-	msec	(3) RD-80S
Luminance of White (Center of screen)	Y_L			TBD	450	-	cd/m ²	(4) SR-3
Color Chromaticity (CIE 1931)	Red		Rx	TYP. -0.03	TBD	TYP. +0.03		(5),(6) SR-3
		Ry	TBD					
	Green	Gx	TBD					
		Gy	TBD					
	Blue	Bx	TBD					
		By	TBD					
	White	Wx	0.280					
		Wy	0.290					
Color Gamut	-		-	80	-	%	(5) SR-3	
Color Temperature	-		-	10,000	-	K		
Viewing Angle	Hor.	θ_L	C/R \geq 10	TBD	89	-	Degree	(6) EZ-Contrast
		θ_R		TBD	89	-		
	Ver.	θ_U		TBD	89	-		
		θ_D		TBD	89	-		
Brightness Uniformity (9 Points)	B_{uni}		-	-	25	%	(2) SR-3	

- Test Equipment Setup

The measurement should be executed in a stable, windless and dark room between 40min and 60min after lighting the back light at the given temperature for stabilization of the back light. This should be measured in the center of screen.

- . LED current = 90mA (for 1EA LED bar)
- . Environment condition : $T_a = 25 \pm 2^\circ\text{C}$

MODEL

LTA400HF05

Doc. No

06-000-G-090312

Page

6 / 29

Photo detector	Field
SR-3	1°
RD-80S	2°

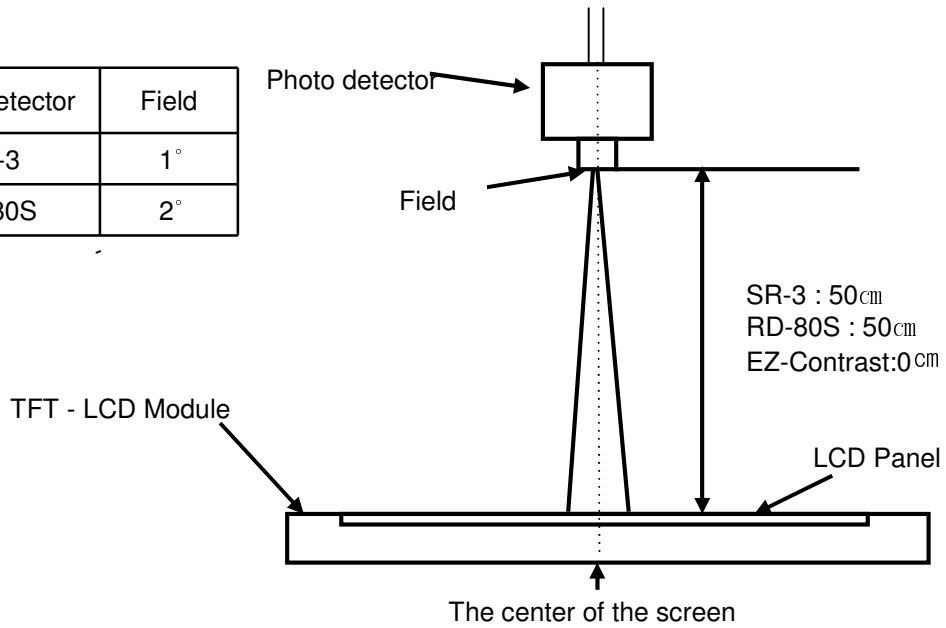

- Definition of test point

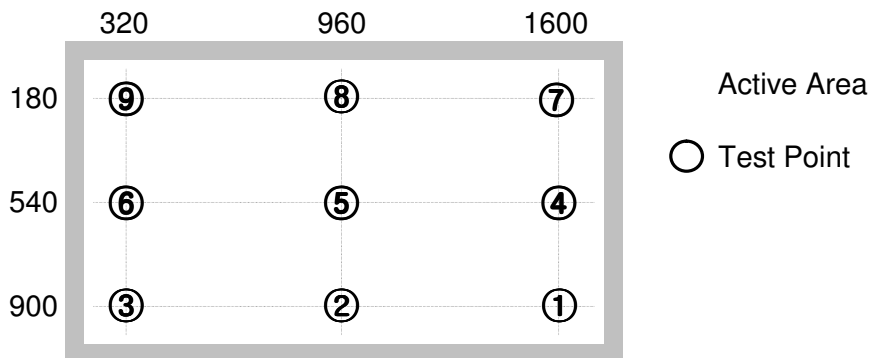

Note (1) Definition of Contrast Ratio (C/R)

: Ratio of gray max (Gmax) & gray min (Gmin) at the center point ⑤ of the panel

$$C/R = \frac{G \max}{G \min}$$

Gmax : Luminance with all pixels white

Gmin : Luminance with all pixels black

MODEL

LTA400HF05

Doc. No

06-000-G-090312

Page

7 / 29

Note (2) Definition of 9 points brightness uniformity (Test pattern : Full White)

$$B_{uni} = 100 * \frac{(B_{max} - B_{min})}{B_{max}}$$

Bmax : Maximum brightness

Bmin : Minimum brightness

Note (3) Definition of Response time : Sum of Tr, Tf

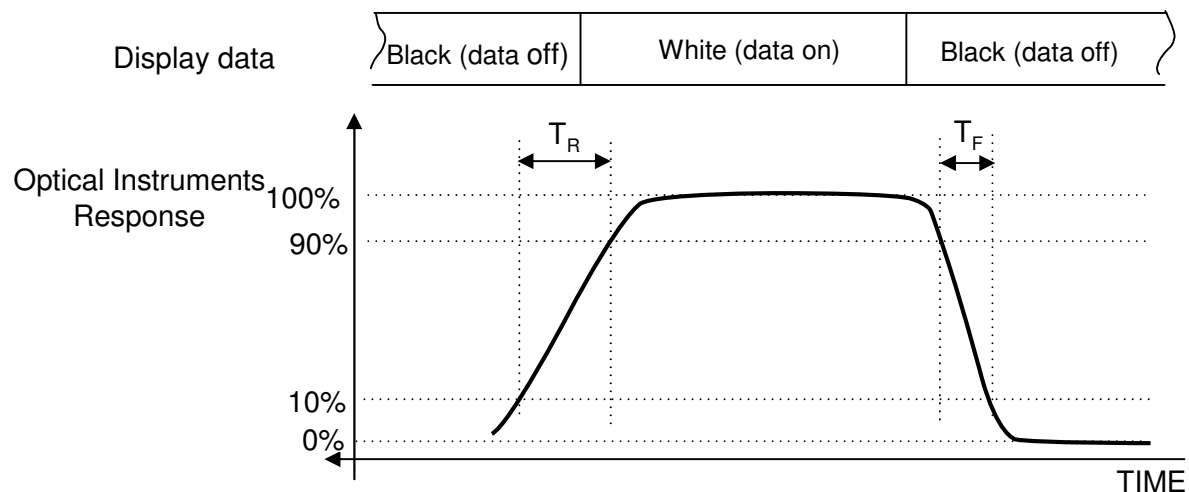

※ G-to-G : Average response time between Gray to Gray (Scale)

Note (4) Definition of Luminance of White : Luminance of white at center point ⑤

Note (5) Definition of Color Chromaticity (CIE 1931)

Color coordinate of Red, Green, Blue & White at center point ⑤

Note (6) Definition of Viewing Angle

: Viewing angle range ($C/R \geq 10$)

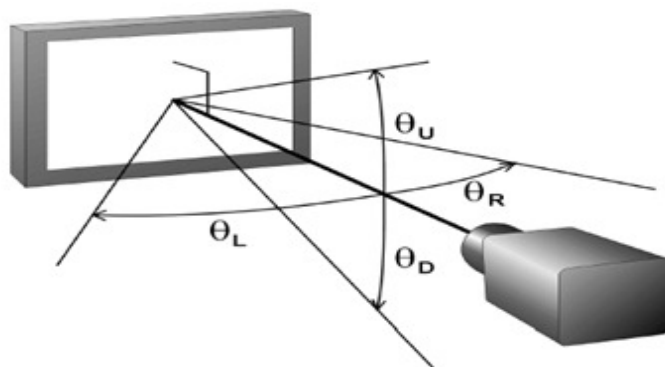

3. Electrical Characteristics

3.1 TFT LCD Module

The connector for display data & timing signal should be connected.

$T_a = 25^\circ\text{C} \pm 2^\circ\text{C}$

Item	Symbol	Min.	Typ.	Max.	Unit	Note
Voltage of Power Supply	V_{DD}	10.8	12.0	13.2	V	(1)
Current of Power Supply	(a) Black	-	1500	TBD	mA	(2),(3)
	(b) White	-	1400	TBD	mA	
	(c) H-STRIPE	-	2600	TBD	mA	
Vsync Frequency	f_v	-	120	-	Hz	
Hsync Frequency	f_H	-	135	-	kHz	
Main Frequency	Fdclk	-	297	-	MHz	
Rush Current	I_{RUSH}	-	-	8	A	(4)

Note (1) The ripple voltage should be controlled under 10% of V_{DD} .

(2) $f_v=120\text{Hz}$, $f_{DCLK}=297\text{MHz}$, $V_{DD}=12.0\text{V}$, DC Current.

(3) Power dissipation check pattern (LCD Module only)

a) Black Pattern

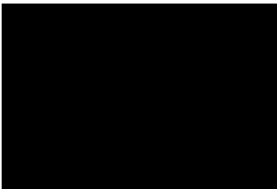

b) White Pattern



c) H-stripe

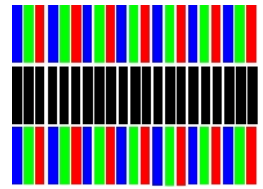

(4) Measurement Conditions

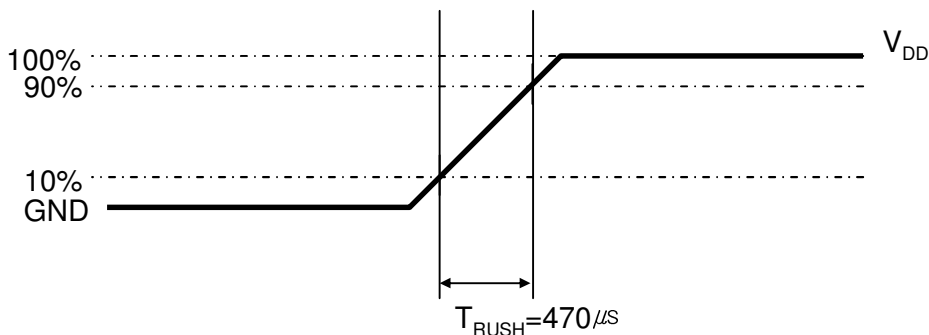

Rush Current I_{RUSH} can be measured when T_{RUSH} is $470\mu\text{s}$.

MODEL

LTA400HF05

Doc. No

06-000-G-090312

Page

9 / 29

3.2 Back Light Unit

The back light unit contains 288 ea WLEDs (White Light Emitting Diode)

$T_a = 25 \pm 2^\circ\text{C}$

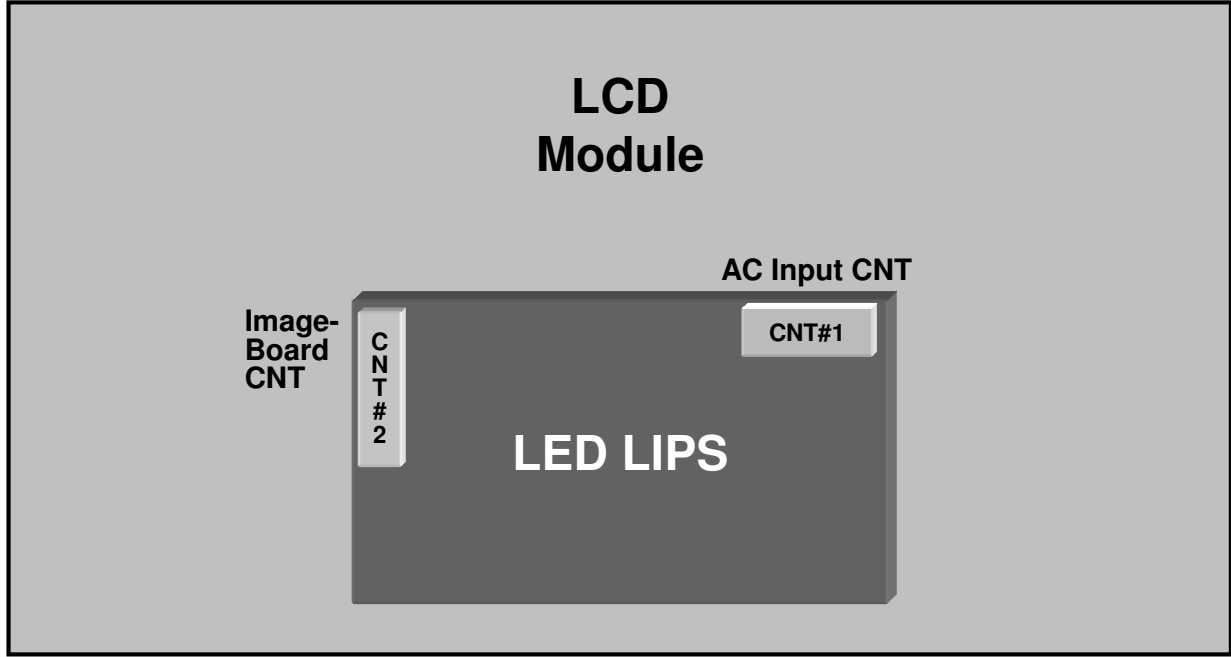

Item	Symbol	Min.	Typ.	Max.	Unit	Note
Operating Life Time	Hr	30,000	-	-	Hour	(1)

Note (1) It is defined as the time to take until the brightness reduces to 50% of its original value.

[Operating condition : $T_a = 25 \pm 2^\circ\text{C}$]

MODEL	LTA400HF05	Doc. No	06-000-G-090312	Page	10 / 29
--------------	-------------------	----------------	------------------------	-------------	----------------

3.3 LED LIPS Condition & Specification

Items	Symbol	Conditions	Specifications			Unit	Note
			Min.	Typ.	Max.		
Input Voltage	V _{in}	-	90	-	264	V _{ac}	Ta=25±2 °C
Input Current	I _{in}	V _{in} =90V	-	-	4.5	Arms	
Output Current (2)	I _{out}	Int_Dim=3.3V	-	90	-	mArms	
		Int_Dim=0V	15	20	25	%	(3)
Dim Frequency	F _{PWM}	V _{in} =90~264V	140	150	160	Hz	
PS On/Off	ON	Floating	-	-	-	V	-
	OFF	Low(GND)	0	-	0.3		
BL On/Off	ON	Floating	-	-	-	V	-
	OFF	Low(GND)	0	-	0.8		
Dimming Control	Int_Dim	Max Lum	3.3	-	-	V	-
		Min. Lum	-	-	0		

Note) Power Consumption is measured when 450[cd/m²] of luminance which is the typical luminance.

(1) All data is measured after 120min warm-up.

(2) AC current Probe : P6022 (Tektronix)

(3) PWM Duty(%) = (T_{on} / T_{total}) * 100

3.4 LED LIPS Output Specification

Items	Symbol	Conditions	Specifications			Unit	Note
			Min.	Typ.	Max.		
+12V	-	V _{in} =100~240V _{ac}	11.4	12.0	12.6	V	Ta=25±2 °C
STB5.3V	-		5.0	5.3	5.5	V	

MODEL

LTA400HF05

Doc. No

06-000-G-090312

Page

11 / 29

4. Block Diagram

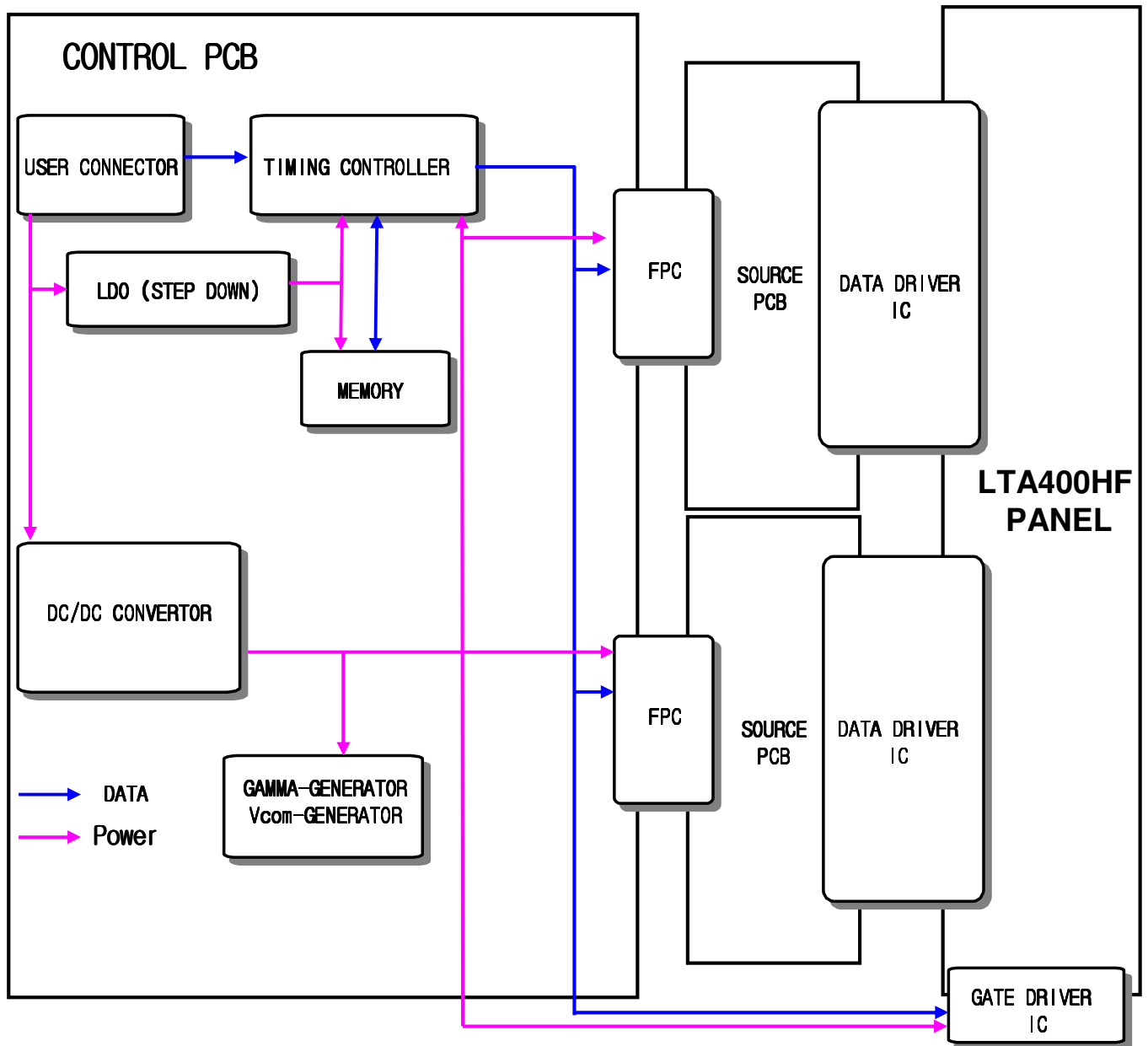

MODEL

LTA400HF05

Doc. No

06-000-G-090312

Page

12 / 29

5. Input Terminal Pin Assignment

5.1. Input Signal & Power

Connector : FI-RE41S-HF (JAE)

Pin	Symbol	Description	Pin	Symbol	Description
1	12V	DC power supply	26	Rx3[0]P	3 rd , 7 th LVDS Signal +
2	12V	DC power supply	27	Rx3[1]N	3 rd , 7 th LVDS Signal -
3	12V	DC power supply	28	Rx3[1]P	3 rd , 7 th LVDS Signal +
4	12V	DC power supply	29	Rx3[2]N	3 rd , 7 th LVDS Signal -
5	12V	DC power supply	30	Rx3[2]P	3 rd , 7 th LVDS Signal +
6	NC	NOTE	31	GND	Ground
7	GND	Ground	32	Rx3CLK-	3 rd , 7 th LVDS Clock -
8	GND	Ground	33	Rx3CLK+	3 rd , 7 th LVDS Clock +
9	GND	Ground	34	GND	Ground
10	Rx1[0]N	1 st , 5 th LVDS Signal -	35	Rx3[3]N	3 rd , 7 th LVDS Signal -
11	Rx1[0]P	1 st , 5 th LVDS Signal +	36	Rx3[3]P	3 rd , 7 th LVDS Signal +
12	Rx1[1]N	1 st , 5 th LVDS Signal -	37	Rx3[4]N	3 rd , 7 th LVDS Signal -
13	Rx1[1]P	1 st , 5 th LVDS Signal +	38	Rx3[4]P	3 rd , 7 th LVDS Signal +
14	Rx1[2]N	1 st , 5 th LVDS Signal -	39	GND	Ground
15	Rx1[2]P	1 st , 5 th LVDS Signal +	40	NC	NOTE
16	GND	Ground	41	NC	
17	Rx1CLK-	1 st , 5 th LVDS Clock -			
18	Rx1CLK+	1 st , 5 th LVDS Clock +			
19	GND	Ground			
20	Rx1[3]N	1 st , 5 th LVDS Signal -			
21	Rx1[3]P	1 st , 5 th LVDS Signal +			
22	Rx1[4]N	1 st , 5 th LVDS Signal -			
23	Rx1[4]P	1 st , 5 th LVDS Signal +			
24	GND	Ground			
25	Rx3[0]N	3 rd , 7 th LVDS Signal -			

NOTE

NC(No Connection) : These PINS are used only for SAMSUNG . (DO NOT CONNECT)

MODEL

LTA400HF05

Doc. No

06-000-G-090312

Page

13 / 29

5. Input Terminal Pin Assignment

5.1. Input Signal & Power

Connector : FI-RE51S-HF (JAE)

Pin	Symbol	Description	Pin	Symbol	Description
1	12V	DC power supply	26	Rx4[0]P	4 th , 8 th LVDS Signal +
2	12V	DC power supply	27	Rx4[1]N	4 th , 8 th LVDS Signal -
3	12V	DC power supply	28	Rx4[1]P	4 th , 8 th LVDS Signal +
4	12V	DC power supply	29	Rx4[2]N	4 th , 8 th LVDS Signal -
5	12V	DC power supply	30	Rx4[2]P	4 th , 8 th LVDS Signal +
6	NC	NOTE1	31	GND	Ground
7	GND	Ground	32	Rx4CLK-	4 th , 8 th LVDS Clock -
8	GND	Ground	33	Rx4CLK+	4 th , 8 th LVDS Clock +
9	GND	Ground	34	GND	Ground
10	Rx2[0]N	2 nd , 6 th LVDS Signal -	35	Rx4[3]N	4 th , 8 th LVDS Signal -
11	Rx2[0]P	2 nd , 6 th LVDS Signal +	36	Rx4[3]P	4 th , 8 th LVDS Signal +
12	Rx2[1]N	2 nd , 6 th LVDS Signal -	37	Rx4[4]N	4 th , 8 th LVDS Signal -
13	Rx2[1]P	2 nd , 6 th LVDS Signal +	38	Rx4[4]P	4 th , 8 th LVDS Signal +
14	Rx2[2]N	2 nd , 6 th LVDS Signal -	39	GND	Ground
15	Rx2[2]P	2 nd , 6 th LVDS Signal +	40	NC	NOTE1
16	GND	Ground	41	NC	
17	Rx2CLK-	2 nd , 6 th LVDS Clock -	42	NC	
18	Rx2CLK+	2 nd , 6 th LVDS Clock +	43	NC	
19	GND	Ground	44	NC	
20	Rx2[3]N	2 nd , 6 th LVDS Signal -	45	LVDS_SEL	NOTE2
21	Rx2[3]P	2 nd , 6 th LVDS Signal +	46	NC	NOTE1
22	Rx2[4]N	2 nd , 6 th LVDS Signal -	47	NC	
23	Rx2[4]P	2 nd , 6 th LVDS Signal +	48	NC	
24	GND	Ground	49	NC	
25	Rx4[0]N	4 th , 8 th LVDS Signal -	50	NC	
			51	NC	

Note1) No Connection: These PINS are used only for SAMSUNG. (DO NOT CONNECT)

Note2) LVDS OPTION : If this PIN is HIGH (3.3 V) → Normal LVDS format

LOW (GND) → JEIDA LVDS format

SEQUENCE : On = $V_{DD}(T1) \geq LVDS\ Option \geq Interface\ Signal(T2)$

OFF = $Interface\ Signal(T3) \geq LVDS\ Option \geq V_{DD}$

MODEL

LTA400HF05

Doc. No

06-000-G-090312

Page

14 / 29

Note(1) Pin number starts from Left side

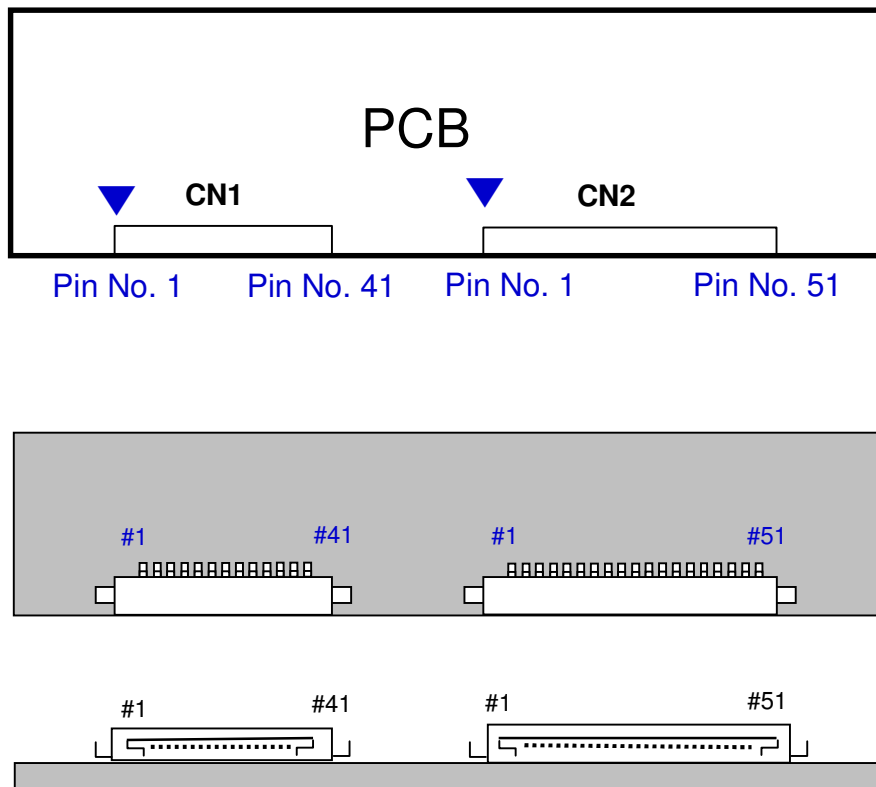

Fig. Connector diagram

- a. Power GND pins should be connected to the LCD's metal chassis.
- b. All power input pins should be connected together.
- c. All NC pin should be separated from other signal or power.

MODEL	LTA400HF05	Doc. No	06-000-G-090312	Page	15 / 29
-------	------------	---------	-----------------	------	---------

5.2 LED LIPD AC Input Pin Configuration

Connector #1 : YAW396-03AV, 2pin (YEONHO)

Pin No.	Pin Configuration (FUNCTION)
1	AC-NEUTRAL
2	AC-LIVE (100V ~ 240V)

5.3 LED LIPS Input & Output Pin Configuration

Connector #2 : SMAW200-12C, 12pin (YEONHO)

Pin No.	Pin Configuration	FUNCTION
1	+12V	OUTPUT
2	+12V	OUTPUT
3	GND	
4	+12V	OUTPUT
5	GND	
6	GND	
7	STB 5.3V	OUTPUT
8	No Connection (DO NOT CONNECT)	
9	GND	
10	PS_ON [ON : Floating, OFF : Low(GND)]	INPUT
11	Dimming Control [0V:Min, 3.3V:Max]	INPUT
12	BL_ON [ON : Floating, OFF : Low(GND)]	INPUT

MODEL

LTA400HF05

Doc. No

06-000-G-090312

Page

16 / 29

5.4 LED LIPS Power sequence

[AC on Sequence]

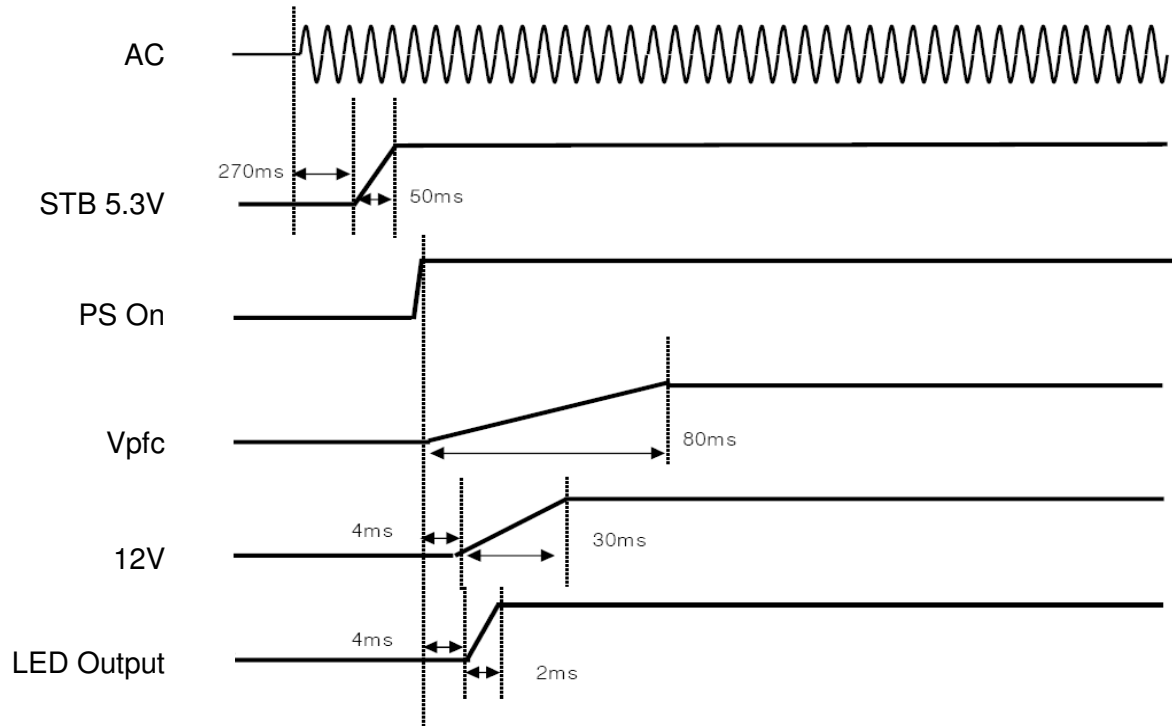

[AC off Sequence]

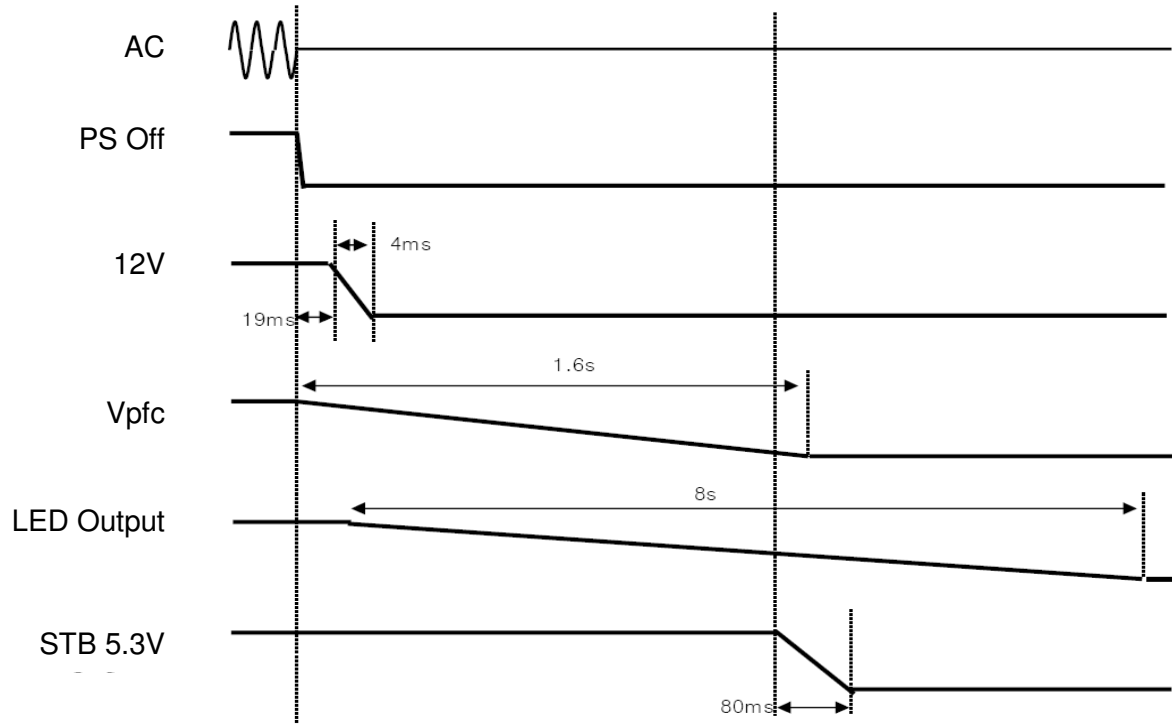

MODEL

LTA400HF05

Doc. No

06-000-G-090312

Page

17 / 29

5.5 LVDS Interface

- LVDS Receiver : Tcon (merged)
- Data Format (JEIDA)

	LVDS pin	JEIDA -DATA	VESA-DATA
TxOUT/RxIN0	TxIN/RxOUT0	R4	R0
	TxIN/RxOUT1	R5	R1
	TxIN/RxOUT2	R6	R2
	TxIN/RxOUT3	R7	R3
	TxIN/RxOUT4	R8	R4
	TxIN/RxOUT6	R9	R5
	TxIN/RxOUT7	G4	G0
TxOUT/RxIN1	TxIN/RxOUT8	G5	G1
	TxIN/RxOUT9	G6	G2
	TxIN/RxOUT12	G7	G3
	TxIN/RxOUT13	G8	G4
	TxIN/RxOUT14	G9	G5
	TxIN/RxOUT15	B4	B0
	TxIN/RxOUT18	B5	B1
TxOUT/RxIN2	TxIN/RxOUT19	B6	B2
	TxIN/RxOUT20	B7	B3
	TxIN/RxOUT21	B8	B4
	TxIN/RxOUT22	B9	B5
	TxIN/RxOUT24	HSYNC	HSYNC
	TxIN/RxOUT25	VSYNC	VSYNC
	TxIN/RxOUT26	DEN	DEN
TxOUT/RxIN3	TxIN/RxOUT27	R2	R6
	TxIN/RxOUT5	R3	R7
	TxIN/RxOUT10	G2	G6
	TxIN/RxOUT11	G3	G7
	TxIN/RxOUT16	B2	B6
	TxIN/RxOUT17	B3	B7
	TxIN/RxOUT23	RESERVED	RESERVED
TxOUT/RxIN4	TxIN/RxOUT28	R0	R8
	TxIN/RxOUT29	R1	R9
	TxIN/RxOUT30	G0	G8
	TxIN/RxOUT31	G1	G9
	TxIN/RxOUT32	B0	B8
	TxIN/RxOUT33	B1	B9
	TxIN/RxOUT34	RESERVED	RESERVED

MODEL

LTA400HF05

Doc. No

06-000-G-090312

Page

18 / 29

5.6 Input Signals, Basic Display Colors and Gray Scale of Each Color

COLOR	DISPLAY (8bit)	DATA SIGNAL																											GRAY SCALE LEVEL						
		RED									GREEN									BLUE															
		R0	R1	R2	R3	R4	R5	R6	R7	R8	R9	G0	G1	G2	G3	G4	G5	G6	G7	G8	G9	B0	B1	B2	B3	B4	B5	B6		B7	B8	B9			
BASIC COLOR	BLACK	0	0	0	0	0	0	0	0	0	0	0	0	0	0	0	0	0	0	0	0	0	0	0	0	0	0	0	0	0	0	0	0	0	-
	BLUE	0	0	0	0	0	0	0	0	0	0	0	0	0	0	0	0	0	0	0	0	0	0	0	0	0	0	0	0	0	0	0	0	0	-
	GREEN	0	0	0	0	0	0	0	0	0	0	0	1	1	1	1	1	1	1	1	1	1	1	0	0	0	0	0	0	0	0	0	0	-	
	CYAN	0	0	0	0	0	0	0	0	0	0	0	1	1	1	1	1	1	1	1	1	1	1	1	1	1	1	1	1	1	1	1	1	-	
	RED	1	1	1	1	1	1	1	1	1	1	0	0	0	0	0	0	0	0	0	0	0	0	0	0	0	0	0	0	0	0	0	0	-	
	MAGENTA	1	1	1	1	1	1	1	1	1	1	0	0	0	0	0	0	0	0	0	0	0	0	0	0	0	0	0	0	0	0	0	0	-	
	YELLOW	1	1	1	1	1	1	1	1	1	1	1	1	1	1	1	1	1	1	1	1	1	0	0	0	0	0	0	0	0	0	0	0	-	
	WHITE	1	1	1	1	1	1	1	1	1	1	1	1	1	1	1	1	1	1	1	1	1	1	1	1	1	1	1	1	1	1	1	1	-	
GRAY SCALE OF RED	BLACK	0	0	0	0	0	0	0	0	0	0	0	0	0	0	0	0	0	0	0	0	0	0	0	0	0	0	0	0	0	0	0	R0		
	DARK ↑	1	0	0	0	0	0	0	0	0	0	0	0	0	0	0	0	0	0	0	0	0	0	0	0	0	0	0	0	0	0	0	R1		
		0	1	0	0	0	0	0	0	0	0	0	0	0	0	0	0	0	0	0	0	0	0	0	0	0	0	0	0	0	0	0	R2		
		:	:	:	:	:	:	:	:	:	:	:	:	:	:	:	:	:	:	:	:	:	:	:	:	:	:	:	:	:	:	:	:	R3~R1020	
		:	:	:	:	:	:	:	:	:	:	:	:	:	:	:	:	:	:	:	:	:	:	:	:	:	:	:	:	:	:	:	:		
	↓ LIGHT	1	0	1	1	1	1	1	1	1	1	0	0	0	0	0	0	0	0	0	0	0	0	0	0	0	0	0	0	0	0	0	R1021		
		0	1	1	1	1	1	1	1	1	1	0	0	0	0	0	0	0	0	0	0	0	0	0	0	0	0	0	0	0	0	0	R1022		
	RED	1	1	1	1	1	1	1	1	1	1	0	0	0	0	0	0	0	0	0	0	0	0	0	0	0	0	0	0	0	0	0	0	R1023	
GRAY SCALE OF GREEN	BLACK	0	0	0	0	0	0	0	0	0	0	0	0	0	0	0	0	0	0	0	0	0	0	0	0	0	0	0	0	0	0	0	0	G0	
	DARK ↑	0	0	0	0	0	0	0	0	0	0	1	0	0	0	0	0	0	0	0	0	0	0	0	0	0	0	0	0	0	0	0	0	G1	
		0	0	0	0	0	0	0	0	0	0	0	1	0	0	0	0	0	0	0	0	0	0	0	0	0	0	0	0	0	0	0	G2		
		:	:	:	:	:	:	:	:	:	:	:	:	:	:	:	:	:	:	:	:	:	:	:	:	:	:	:	:	:	:	:	G3~G1020		
		:	:	:	:	:	:	:	:	:	:	:	:	:	:	:	:	:	:	:	:	:	:	:	:	:	:	:	:	:	:	:			
	↓ LIGHT	0	0	0	0	0	0	0	0	0	0	1	0	1	1	1	1	1	1	1	1	1	0	0	0	0	0	0	0	0	0	0	G1021		
		0	0	0	0	0	0	0	0	0	0	0	1	1	1	1	1	1	1	1	1	1	0	0	0	0	0	0	0	0	0	0	G1022		
	GREEN	0	0	0	0	0	0	0	0	0	0	1	1	1	1	1	1	1	1	1	1	1	0	0	0	0	0	0	0	0	0	0	G1023		
GRAY SCALE OF BLUE	BLACK	0	0	0	0	0	0	0	0	0	0	0	0	0	0	0	0	0	0	0	0	0	0	0	0	0	0	0	0	0	0	0	B0		
	DARK ↑	0	0	0	0	0	0	0	0	0	0	0	0	0	0	0	0	0	0	0	0	0	1	0	0	0	0	0	0	0	0	0	B1		
		0	0	0	0	0	0	0	0	0	0	0	0	0	0	0	0	0	0	0	0	0	0	1	0	0	0	0	0	0	0	0	B2		
		:	:	:	:	:	:	:	:	:	:	:	:	:	:	:	:	:	:	:	:	:	:	:	:	:	:	:	:	:	:	:	B3~B1020		
		:	:	:	:	:	:	:	:	:	:	:	:	:	:	:	:	:	:	:	:	:	:	:	:	:	:	:	:	:	:	:			
	↓ LIGHT	0	0	0	0	0	0	0	0	0	0	0	0	0	0	0	0	0	0	0	0	0	0	1	0	1	1	1	1	1	1	1	B1021		
		0	0	0	0	0	0	0	0	0	0	0	0	0	0	0	0	0	0	0	0	0	0	1	1	1	1	1	1	1	1	1	B1022		
	BLUE	0	0	0	0	0	0	0	0	0	0	0	0	0	0	0	0	0	0	0	0	0	0	1	1	1	1	1	1	1	1	1	B1023		

Note) Definition of Gray :
 Rn : Red Gray, Gn : Green Gray, Bn : Blue Gray (n = Gray level)
 Input Signal : 0 = Low level voltage, 1 = High level voltage

6. Interface Timing

6.1 Timing Parameters (DE only mode)

SIGNAL	ITEM	SYMBOL	MIN.	TYP.	MAX.	Unit	NOTE
Clock	Frequency	$1/T_C$	TBD	297	TBD	MHz	-
Hsync		F_H	TBD	135	TBD	KHz	-
Vsync		F_V	TBD	120	TBD	Hz	-
Vertical Display Term	Active Display Period	T_{VD}	-	1080	-	Lines	-
	Vertical Total	T_V	TBD	1125	TBD	Lines	-
Horizontal Display Term	Active Display Period	T_{HD}	-	1920	-	Clocks	-
	Horizontal Total	T_H	TBD	2200	TBD	clocks	-

Note) This product is DE only mode. The input of Hsync & Vsync signal does not have an effect on normal operation.

- (1) Test Point : TTL control signal and CLK at LVDS Tx input terminal in system
- (2) Internal $V_{DD} = 3.3V$
- (3) Spread spectrum
 - Modulation rate (max) : $\pm 1.5 \%$
 - Modulation Frequency : under 100KHz

6.2 Timing diagrams of interface signal (DE only mode)

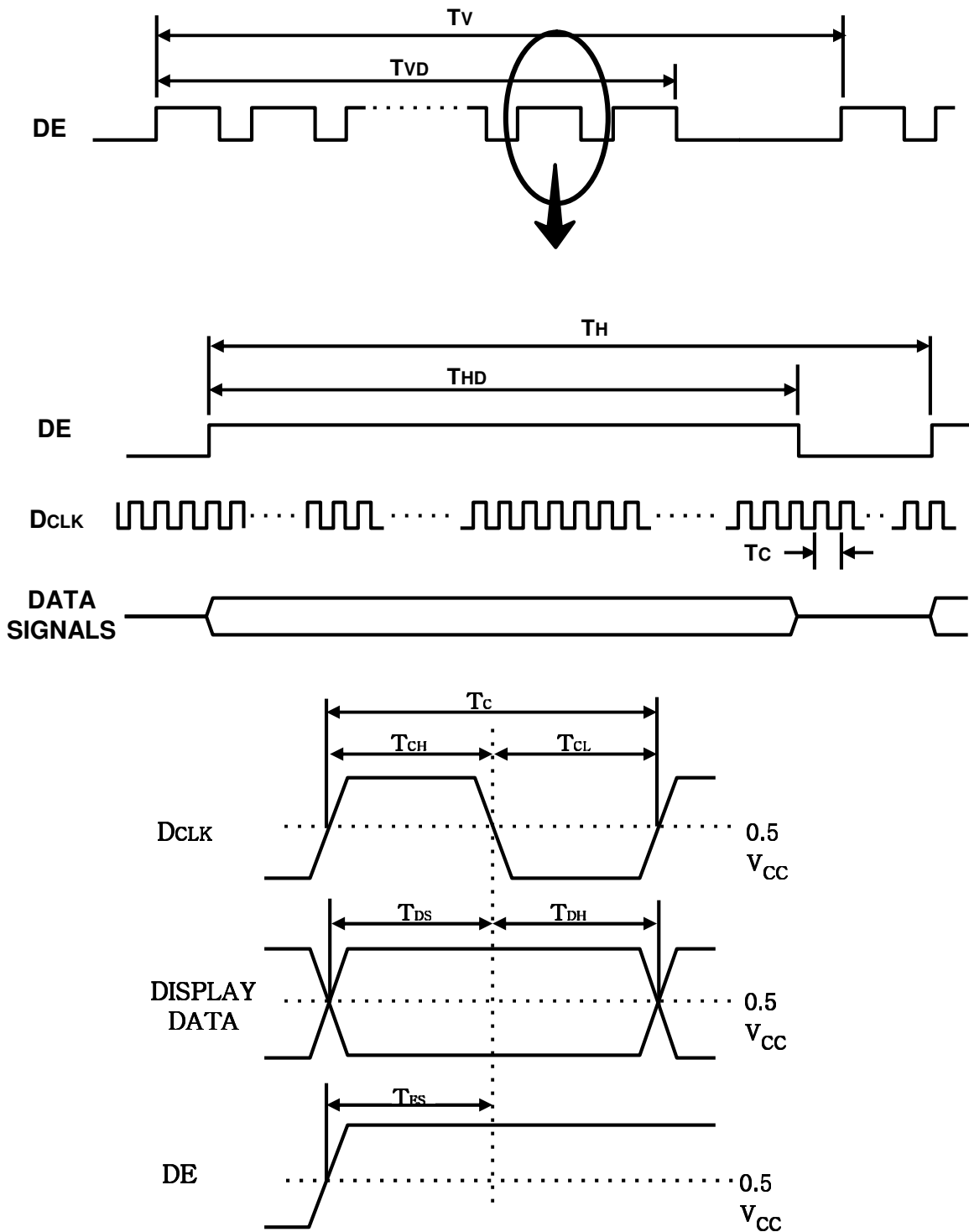

6.3 Power ON/OFF Sequence

To prevent a latch-up or DC operation of the LCD Module, the power on/off sequence should be as the diagram below.

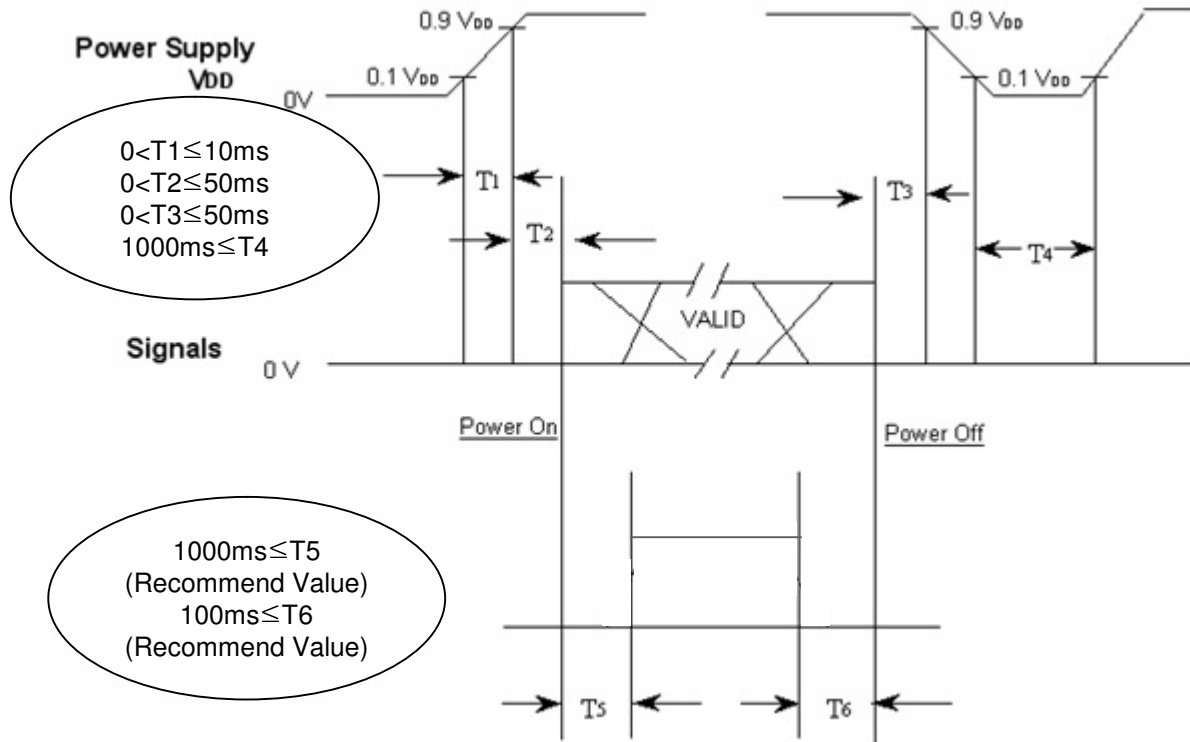

- $T1$: V_{DD} rising time from 10% to 90%
- $T2$: The time from V_{DD} to valid data at power ON.
- $T3$: The time from valid data off to V_{DD} off at power Off.
- $T4$: V_{DD} off time for Windows restart
- $T5$: The time from valid data to B/L enable at power ON.
- $T6$: The time from valid data off to B/L disable at power Off.

- The supply voltage of the external system for the Module input should be the same as the definition of V_{DD} .
- Apply the lamp voltage within the LCD operation range. When the back light turns on before the LCD operation or the LCD turns off before the back light turns off, the display may momentarily show abnormal screen.
- In case of V_{DD} = off level, please keep the level of input signals low or keep a high impedance.
- $T4$ should be measured after the Module has been fully discharged between power off and on period.
- Interface signal should not be kept at high impedance when the power is on.

MODEL	LTA400HF05	Doc. No	06-000-G-090312	Page	22 / 29
-------	------------	---------	-----------------	------	---------

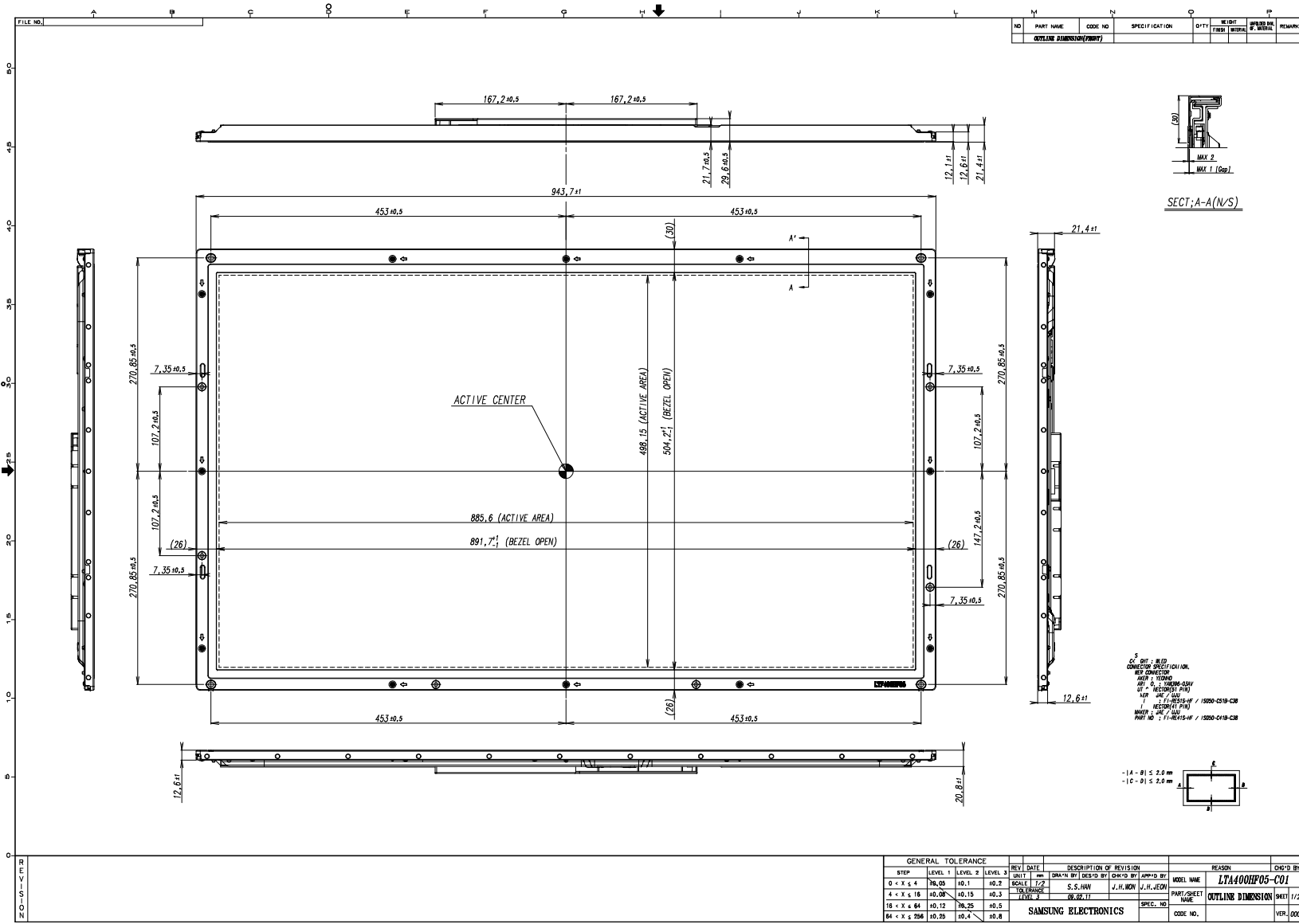

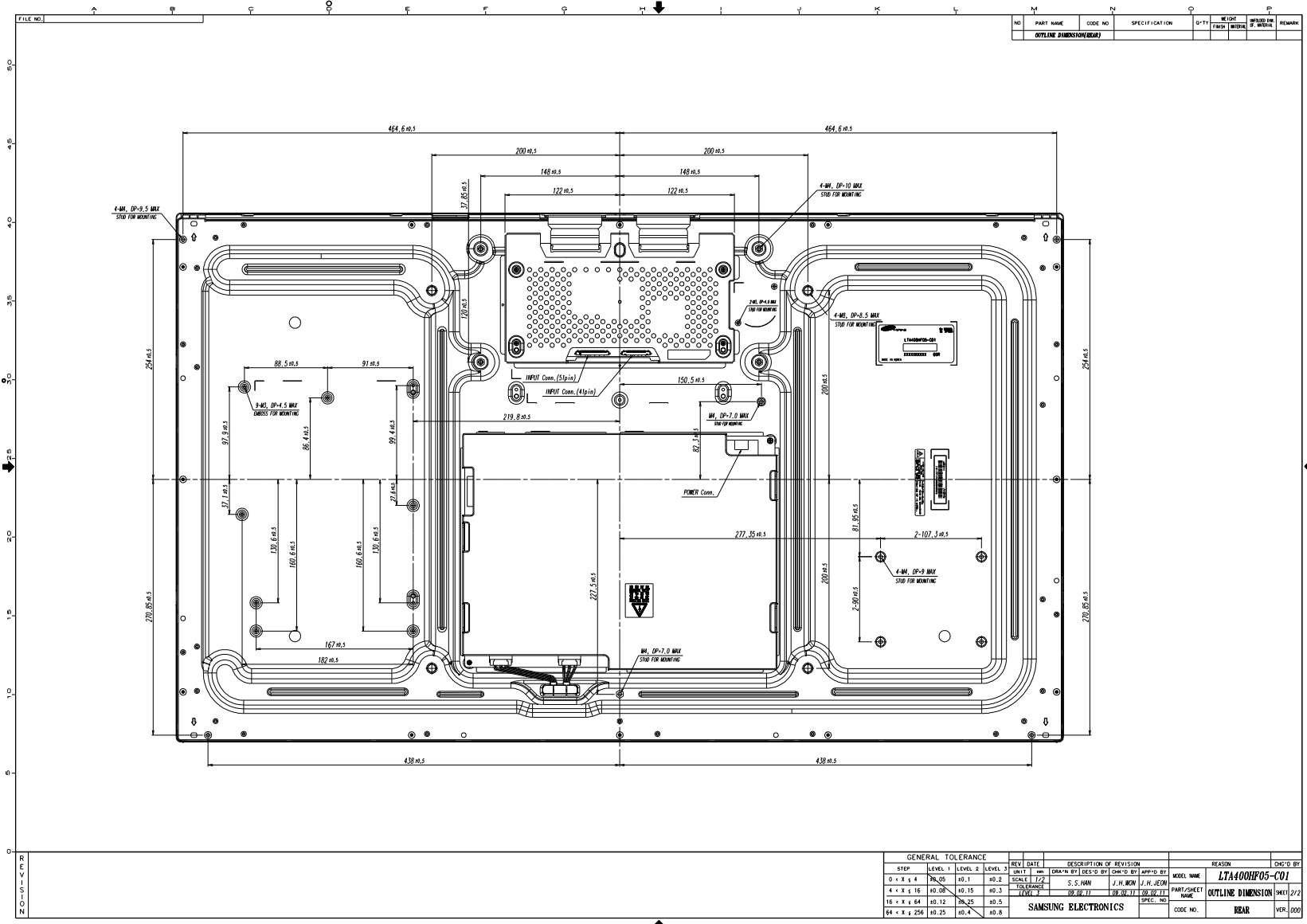

NO.	PART NAME	CODE NO.	SPECIFICATION	D-TYPE	WEIGHT	REFL. NO.	REMARK
OUTLINE DIMENSION (REAR)							

GENERAL TOLERANCE				REV	DATE	DESCRIPTION OF REVISION			REASON		CHK'D BY
STEP	LEVEL 1	LEVEL 2	LEVEL 3	UNIT	mm	DRAWN BY	DES'D BY	CHK'D BY	APP'D BY	MODEL NAME	
0 * X * 4	20.00	±0.1	±0.2	SCALE	1:2	S.S. MAN	J.H. WON	J.H. REW		LTA400H05-C01	
4 * X * 16	30.00	±0.15	±0.3	TOLERANCE							
16 * X * 64	40.12	±0.25	±0.5	100%							
64 * X * 256	40.25	±0.4	±0.8								
SAMSUNG ELECTRONICS						PART SHEET NAME	CODE NO.	REAR	VER.	000	

8. PACKING

8.1 CARTON (Internal Package)

(1) Packing Form

Corrugated fiberboard box and corrugated cardboard as shock absorber

(2) Packing Method

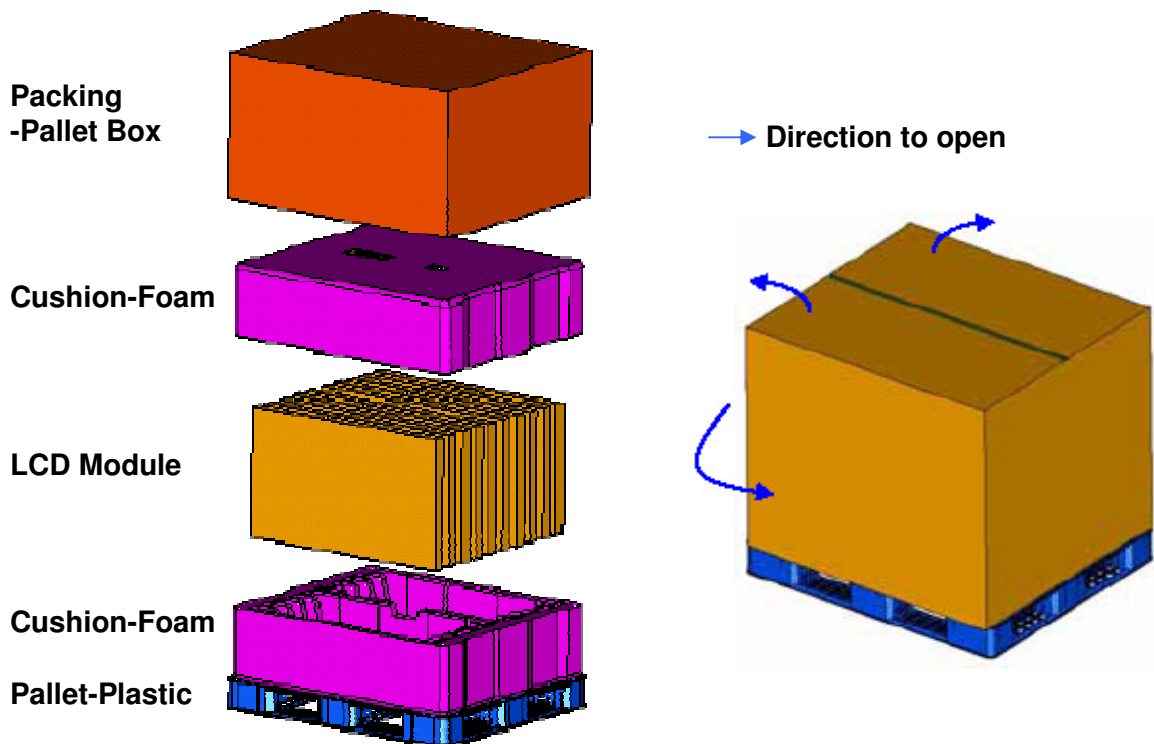

8.2 Packing Specification

Item	Specification	Remark
LCD Packing	12ea / (Packing-Pallet Box)	1. 120 Kg / LCD (12ea) 2. 7 Kg / Cushion-pallet (2ea) 3. 6.7 Kg / Packing-Pallet Box (1ea) 4. Cushion-pallet Material : EPS 5. Packing-Pallet Box Material : DW4
Pallet	1Box / Pallet	1. Pallet weight = 8 kg
Packing Direction	Vertical	
Total Pallet Size	H x V x height	1150mm(H) x 985mm(V) x 609mm(height)
Total Pallet Weight	142.7 kg	Pallet(8kg) + Module(120kg) + Cushion(up+bottom=7kg) + Pallet-BOX(6.7kg)

MODEL

LTA400HF05

Doc. No

06-000-G-090312

Page

25 / 29

9. MARKING & OTHERS

A nameplate bearing followed by is affixed to a shipped product at the specified location on each product.

- (1) Part number : LTA400HF05
- (2) Revision: Three letters
- (3) Lot number : X X X X XXX XX X

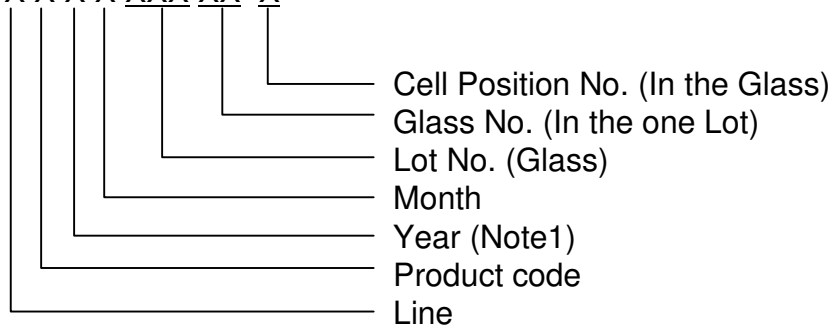

(4) Nameplate Indication

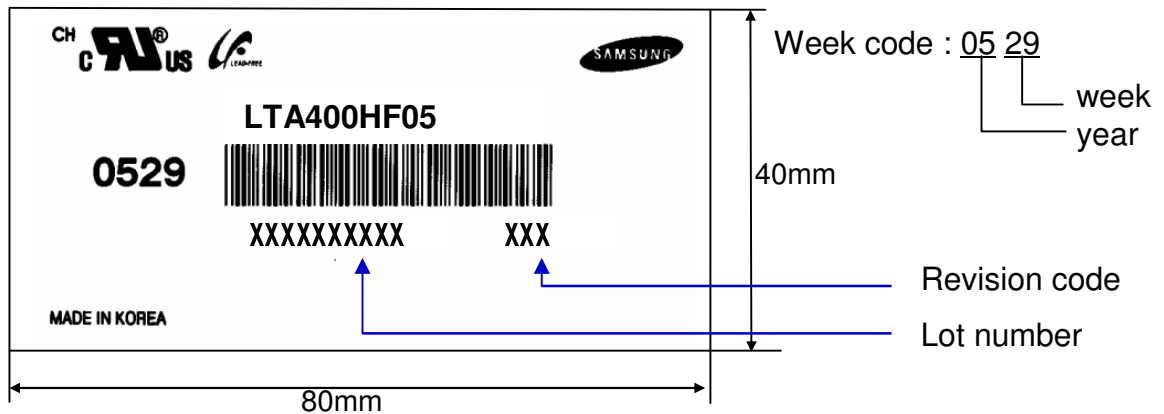

(5) Packing box attach

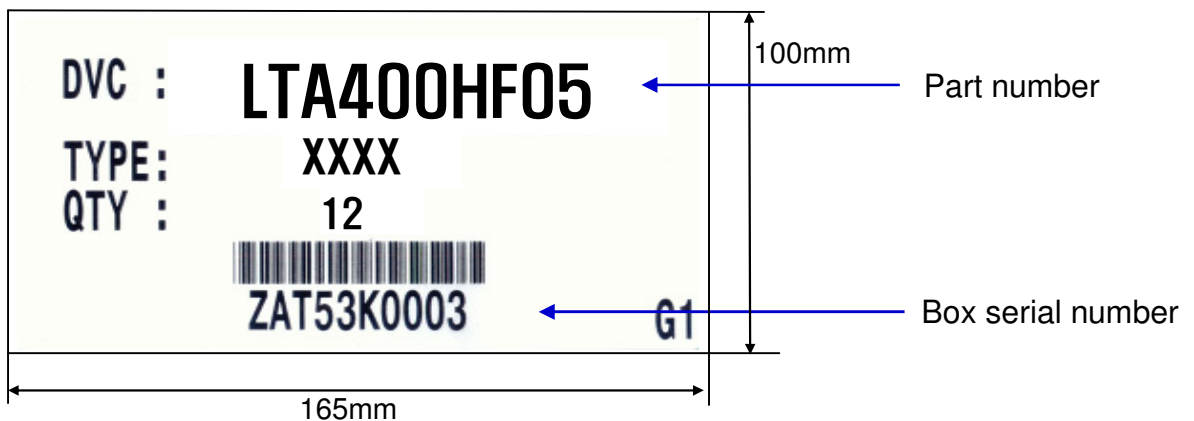

(6) Others

- 1. After service part

Lamps cannot be replaced because of the narrow bezel structure.

MODEL	LTA400HF05	Doc. No	06-000-G-090312	Page	26 / 29
-------	------------	---------	-----------------	------	---------

10. General Precautions

10.1 Handling

- (a) When the Module is assembled, it should be attached to the system firmly using all mounting holes. Be careful not to twist and bend the Module.
- (b) Because the inverter use high voltage, it should be disconnected from power before it is assembled or disassembled.
- (c) Refrain from strong mechanical shock and / or any force to the Module. In addition to damage, this may cause improper operation or damage to the Module and LED back light.
- (d) Note that polarizers are very fragile and could be damage easily. Do not press or scratch the surface harder than a HB pencil lead.
- (e) Wipe off water droplets or oil immediately. If you leave the droplets for a long time, staining or discoloration may occur.
- (f) If the surface of the polarizer is dirty, clean it using absorbent cotton or soft cloth.
- (g) Desirable cleaners are water, IPA(Isopropyl Alcohol) or Hexane. Do not use Ketone type materials(ex. Acetone), Ethyl alcohol, Toluene, Ethyl acid or Methyl chloride. It might permanent damage to the polarizer due to chemical reaction.
- (h) If the liquid crystal material leaks from the panel, it should be kept away from the eyes or mouth . In case of contact with hands, legs or clothes, it must be washed away with soap thoroughly.
- (i) Protect the module from Electrostatic discharge. Otherwise the ASIC IC or Semiconductor would be damaged.
- (j) Use finger-stalls with soft gloves in order to keep display clean during the incoming inspection and assembly process.
- (k) Do not disassemble the Module.
- (l) Do not disassemble shield case of inverter & LVDS board.
- (m) Do not connect N.C pins. (Samsung internal use only)
- (n) Protection film for polarizer on the Module should be slowly peeled off just before use so that the electrostatic charge can be minimized. Must put on antistatic glove while handle a module
- (o) Pins of I/F connector should not be touched directly with bare hands.

MODEL

LTA400HF05

Doc. No

06-000-G-090312

Page

27 / 29

10.2 Storage

- (a) Do not leave the Module in high temperature, and high humidity for a long time. It is highly recommended to store the Module with temperature from 0 to 35 °C and relative humidity of less than 70%.
- (b) Do not store the TFT-LCD Module in direct sunlight.
- (c) The Module should be stored in a dark place. It is prohibited to apply sunlight or fluorescent light in storing.

10.3 Operation

- (a) Do not connect or disconnect the Module in the "Power On" condition.
- (b) Power supply should always be turned on/off by the "Power on/off sequence"
- (c) Module has high frequency circuits. Sufficient suppression to the electromagnetic interference should be done by system manufacturers. Grounding and shielding methods may be important to minimize the interference.
- (d) The cable between the back light connector and its inverter power supply should be connected directly with a minimized length. A longer cable between the back light and the inverter may cause lower luminance of LED and may require higher startup voltage(Vs).

10.4 Operation Condition Guide

- (a) The LCD product should be operated under normal conditions.
Normal condition is defined as below;
 - Temperature : 20 ± 15 °C
 - Humidity : 55 ± 20 %
 - Display pattern : continually changing pattern (Not stationary)
- (b) If the product will be used in extreme conditions such as high temperature, humidity, display patterns or operation time etc., It is strongly recommended to contact SEC for Application engineering advice. Otherwise, its reliability and function may not be guaranteed. Extreme conditions are commonly found at Airports, Transit Stations, Banks, Stock market, and Controlling systems.

MODEL	LTA400HF05	Doc. No	06-000-G-090312	Page	28 / 29
--------------	-------------------	----------------	------------------------	-------------	----------------

10.5 Others

- (a) Ultra-violet ray filter is necessary for outdoor operation.
- (b) Avoid condensation of water. It may result in improper operation or disconnection of electrode.
- (c) Do not exceed the absolute maximum rating value. (supply voltage variation, input voltage variation, variation in part contents and environmental temperature, and so on)
Otherwise the Module may be damaged.
- (d) If the Module keeps displaying the same pattern for a long period of time, the image may be "sticked " to the screen.
To avoid image sticking, it is recommended to use a screen saver.
- (e) This Module has its circuitry PCB's on the rear side and should be handled carefully in order not to be stressed.
- (f) Please contact SEC in advance when you display the same pattern for a long time.

MODEL	LTA400HF05	Doc. No	06-000-G-090312	Page	29 / 29
--------------	-------------------	----------------	------------------------	-------------	----------------