

THE INFORMATION CONTAINED IN THIS DRAWING IS THE SOLE PROPERTY OF BUD INDUSTRIES INC. ANY REPRODUCTION IN PART OR WHOLE WITHOUT THE WRITTEN PERMISSION OF BUD INDUSTRIES INC. IS PROHIBITED.

DWG. NO.	SNB-3735
ISSUE	REVISIONS
(A)	PER ECN #10446 1-13-09 BT

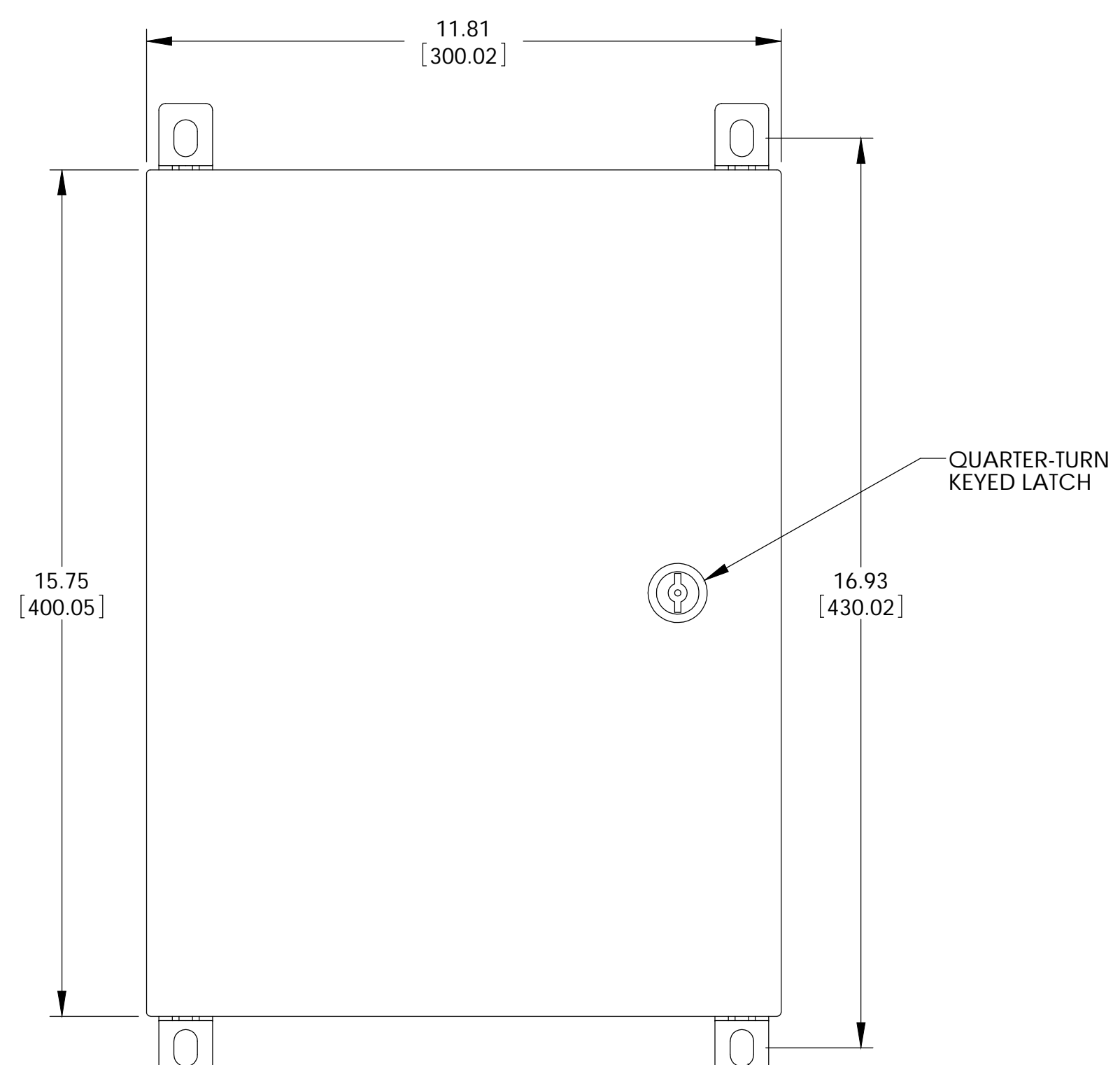

WALL MOUNTING BRACKET KIT TO CONTAIN THE FOLLOWING:  
(4) BRACKETS, (4) BOLTS, (4) SEALING WASHERS, (4) FLAT WASHERS, (4) LOCKWASHERS & (4) HEX NUTS

(A) 10.35 [262.94] .437 [11.10] x .687 [17.45] OBLONG EACH BRACKET

M8 x 16mm LG. WELD STUD/STANDOFF (4x) (FLAT WASHER, LOCKWASHER & HEX NUT FOR INTERNAL PANEL MOUNTING)

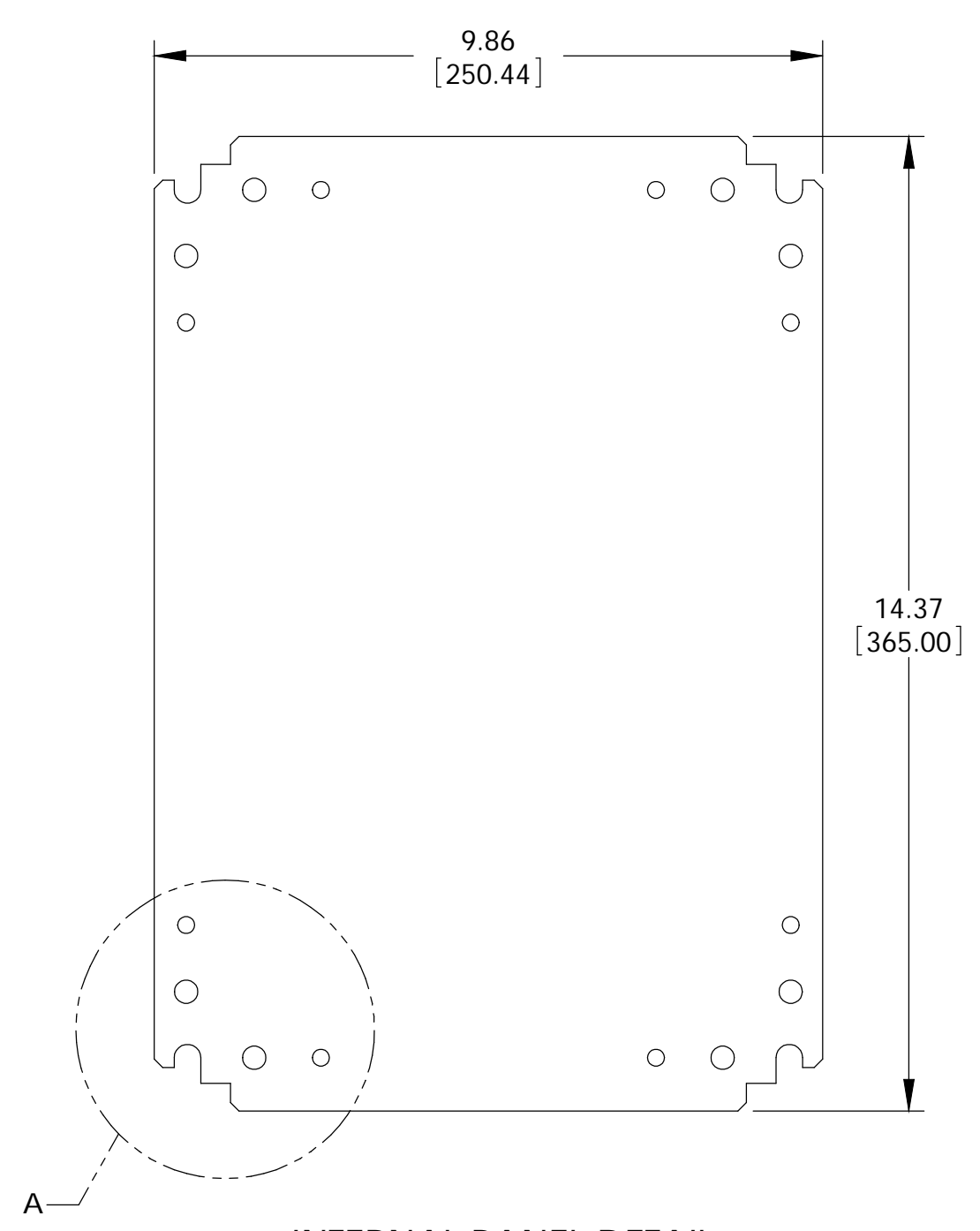

INTERNAL PANEL DETAIL

FRONT VIEW (LESS COVER)

NO GAP BETWEEN GASKET JOINT. OPTIONALLY JOINT MAY BE SEALED WITH ADHESIVE.

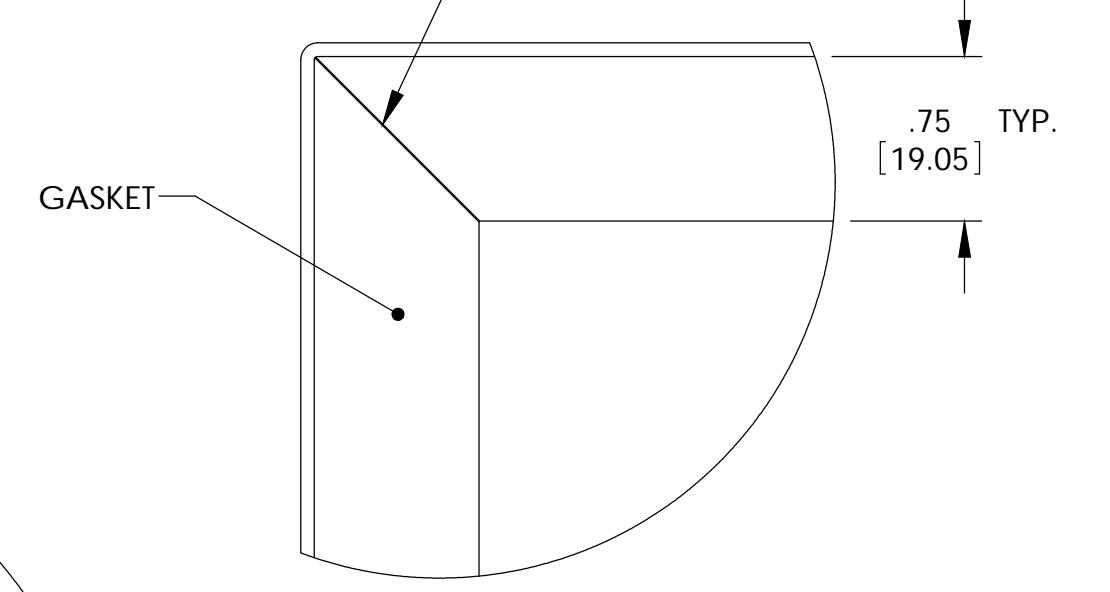

DETAIL B SCALE 2 : 1.75

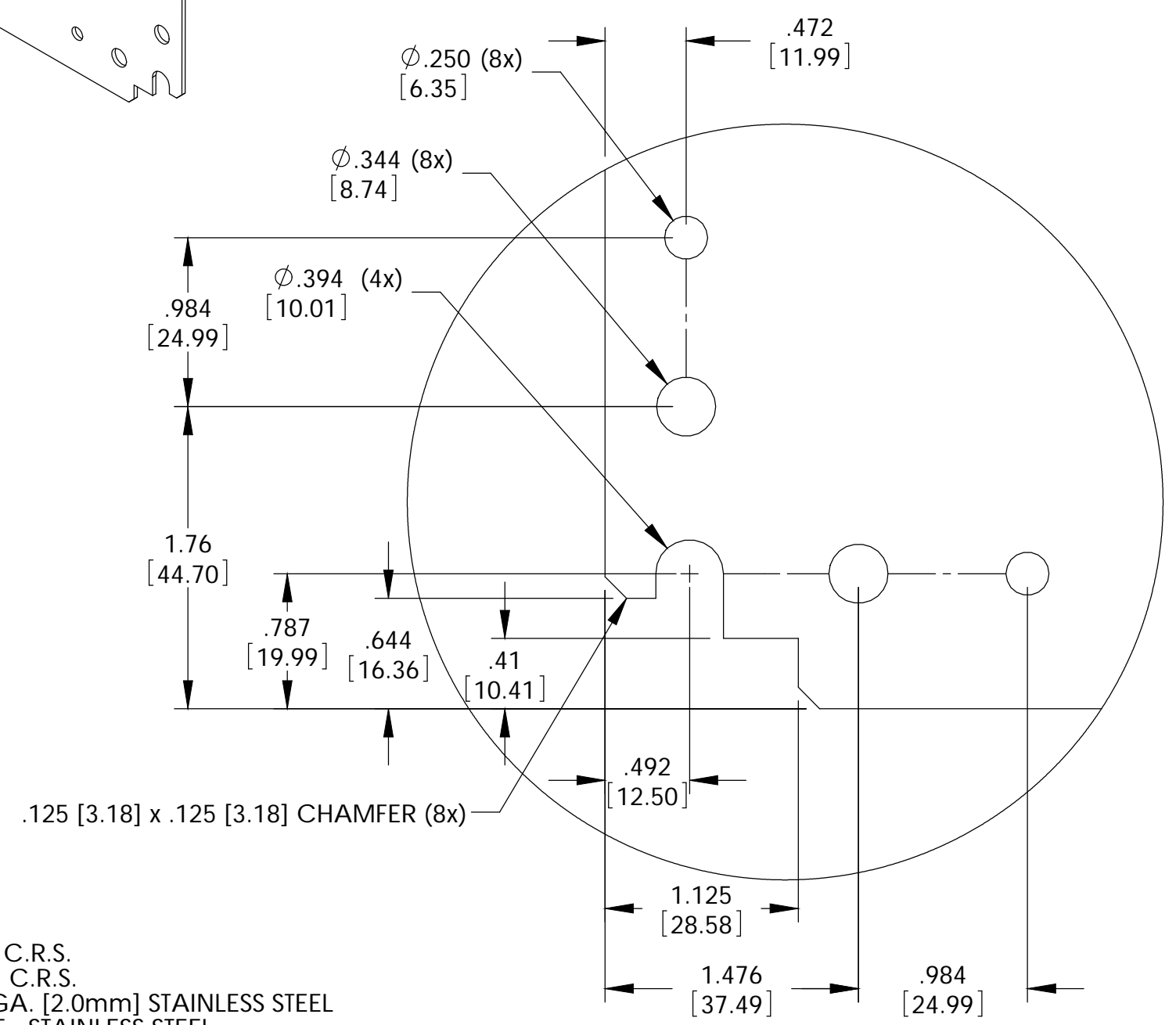

DETAIL A SCALE 2 : 1.75

**MATERIAL:**  
 BODY & COVER - 16 GA. [1.5mm] C.R.S.  
 INTERNAL PANEL - 14 GA. [2.0mm] C.R.S.  
 WALL MOUNTING BRACKETS - 14 GA. [2.0mm] STAINLESS STEEL  
 HINGE PINS, STRIKER & HARDWARE - STAINLESS STEEL  
 GASKET - .250 [6.35] THICK NEOPRENE (BLACK) OR EQUIVALENT  
 SEALING WASHERS - BLACK NEOPRENE OR EQUIVALENT

**FINISH:**  
 BODY & COVER - LIGHT GRAY SMOOTH POWDER COAT  
 INTERNAL PANEL - ZINC CHROMATE  
 WALL MOUNTING BRACKETS, HINGE PINS, STRIKER - NATURAL

PARTS LIST		BUD INDUSTRIES INC.	
UNLESS OTHERWISE SPECIFIED ALL DIMENSIONS ARE IN INCHES (MILLIMETERS)	CAD GENERATED DRAWING. DO NOT MANUALLY UPDATE.	DATE	9-21-07
DESIGNED BY	APPROVED BY	DRAWN BY	DAB
CHECKED BY	DATE	DATE	9-21-07
MATERIAL		NEMA SHEET METAL BOX	
AS NOTED		AS NOTED	

QTY.	USED ON	DO NOT SCALE DRAWING	APPROVED	SCALE	DWG. NO.	REV.
					SNB-3735	
					SCALE	SHEET 1 OF 1