

T-1 (3 mm) Auto Insertable LED Lamps

Technical Data

HLMP-E100	HLMP-E150
HLMP-E200	HLMP-E250
HLMP-E300	HLMP-E350
HLMP-E400	HLMP-E450
HLMP-E500	HLMP-E550

Features

- **T-1 Auto Insertable**
- **High Light Output**
- **Tinted Diffused and Tinted Non-Diffused Lens Options**
- **Wide Viewing Angle**
- **Variety of Colors**
- **Available with Straight Lead Tape and Reel Options or in Bulk**

Description

This family of 3 mm LED Lamps is specially designed for automatic insertion and wave soldering processes.

Designed with a thick epoxy flange, it is ideal for flush mount auto insertion.

Applications

- **General Purpose**
- **High Volume Manufacturing**

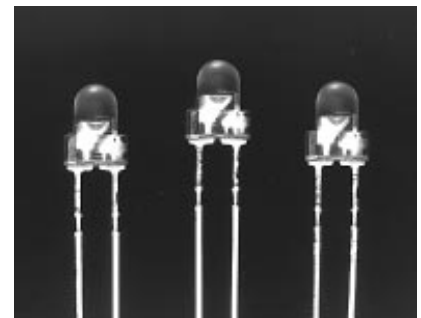

Device Selection Guides

Part Number	Color	Package		Luminous Intensity I _v (mcd @ 20 mA) Typ.	Typical Viewing Angle (Degrees) 2θ _{1/2} ^[1]
		Diff.	Tint		
HLMP-E100 HLMP-E150	AS AlGaAs Red	X	X	42 110	60 45
HLMP-E200 HLMP-E250	Orange	X	X	22 28	60 45
HLMP-E300 HLMP-E350	High Efficiency Red (HER)	X	X	12 38	60 45
HLMP-E400 HLMP-E450	Yellow	X	X	15 27	60 45
HLMP-E500 HLMP-E550	High Performance Green	X	X	28 48	60 45

Note:

1. 2θ_{1/2} is the off axis angle where the luminous intensity is 1/2 the on axis intensity.

Package Dimensions

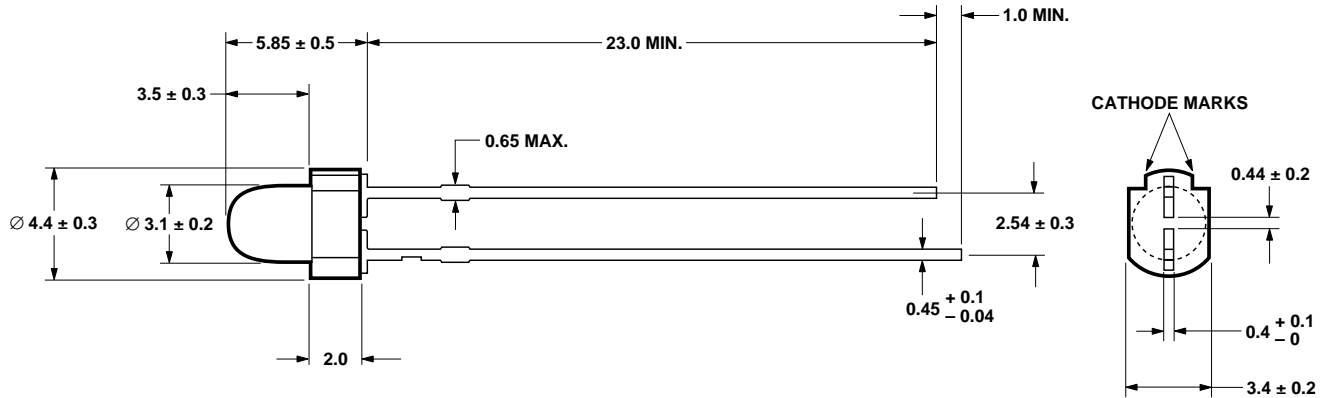

NOTES:

1. ALL DIMENSIONS ARE IN MILLIMETERS (INCHES).
2. LEADS ARE MILD STEEL, SOLDER DIPPED.
3. ALL EPOXY MENISCUS MAY EXTEND ABOUT 0.8 mm (0.030 in.) DOWN THE LEADS.

Absolute Maximum Ratings at $T_A = 25\text{ }^\circ\text{C}$

Parameter	High Efficiency Red and Orange	Yellow	High Performance Green	AS AlGaAs Red	Units
DC Forward Current	30	20	30	30	mA
Reverse Voltage ($I_r = 100\text{ }\mu\text{A}$)	5				V
Junction Temperature, T_{jmax}	110				$^\circ\text{C}$
Storage Temperature Range	-40 to +85				$^\circ\text{C}$
Operating Temperature Range	-20 to +85			-40 to +85	$^\circ\text{C}$
Lead Soldering Temperature [1.6 mm (0.063 in.) from seating plane]	A) DIP/DRAG Soldering: 260 $^\circ\text{C}$ for 5 seconds B) Wave Solder Temperature: 245 $^\circ\text{C}$ for 3 seconds				

Notes:

1. See Figure 4 for maximum current derating vs. ambient temperature.
2. Suggested minimum DC current: 10 mA
3. Maximum Peak Pulsed Forward Current: 50 mA, 30 mA average.

Electrical Characteristics at $T_A = 25\text{ }^\circ\text{C}$

Part Number	Forward Voltage Vf (Volts)			Capacitance C (pF) Vf = 0, f = 1 MHz Typ.	Thermal Resistance $R\theta_{J-PIN}$ ($^\circ\text{C/W}$)	Speed of Response τ_s (ns) Time Constant e^{-t}/τ_s Typ.
	Typ.	Max.	If (mA)			
HLMP-E1XX	1.80	2.2	20	30	290	30
HLMP-E2XX	1.90	2.4	10	4	290	280
HLMP-E3XX	1.90	2.4	10	11	290	90
HLMP-E4XX	2.00	2.4	10	15	290	90
HLMP-E5XX	2.10	2.7	10	18	290	500

Optical Characteristics at $T_A = 25\text{ }^\circ\text{C}$

Part Number	Luminous Intensity I_v (mcd) ^[1]			Peak Wavelength λ_{peak} (nm) Typ.	Color Dominant Wavelength λ_d ^[2] (nm) Typ.	Spectral Half Width Typ.	Luminous Efficacy η_v ^[3] (lm/W)
	Min.	Typ.	If (mA)				
HLMP-E100	13.8	42	20	645	637	27	80
HLMP-E150	35.2	110	20				
HLMP-E200	5.4	22	10	600	604	37	380
HLMP-E250	13.8	28	10				
HLMP-E300	8.6	12	10				
HLMP-E350	13.8	38	10	635	626	40	145
HLMP-E400	9.2	15	10				
HLMP-E450	14.7	27	10	583	585	36	500
HLMP-E500	10.6	28	10				
HLMP-E550	17	48	10	565	570	28	595

Notes:

1. The luminous intensity, I_v , is measured at the mechanical axis of the lamp package. The actual peak of the spatial radiation pattern may not be aligned with this axis.
2. The dominant wavelength, λ_d , is derived from the CIE Chromaticity Diagram and represents the color of the device.
3. The radiant intensity, I_e , in watts per steradian, may be found from the equation $I_e = I_v/\eta_v$, where I_v is the luminous intensity in candelas and η_v is the luminous efficacy in lumens/watt.

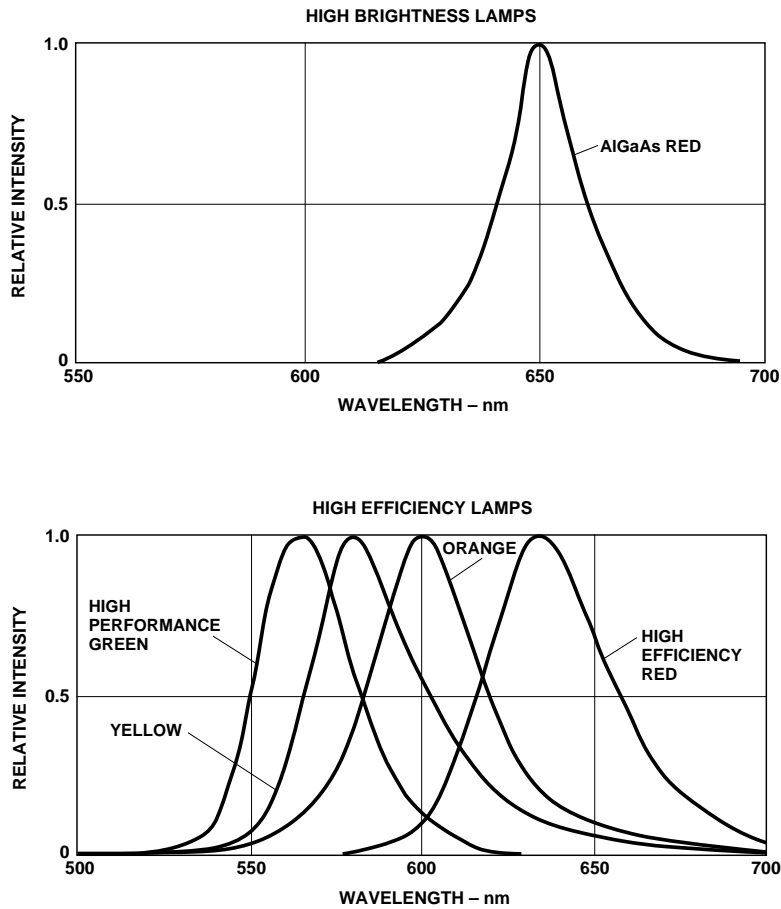

Figure 1. Relative Intensity vs. Peak Wavelength.

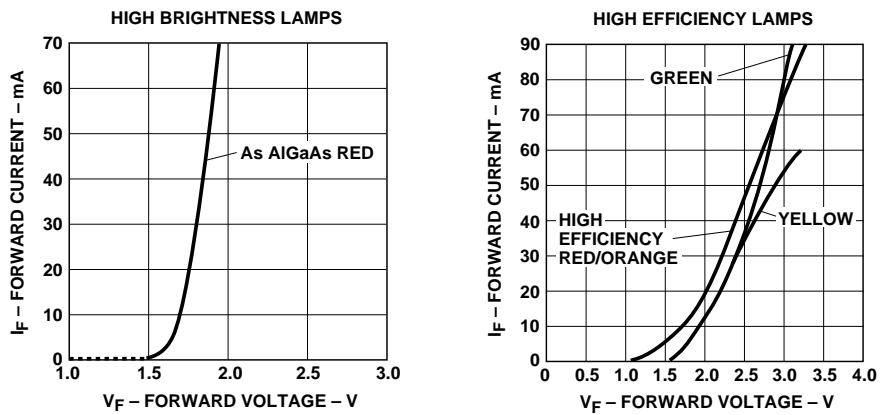

Figure 2. Forward Current vs. Forward Voltage.

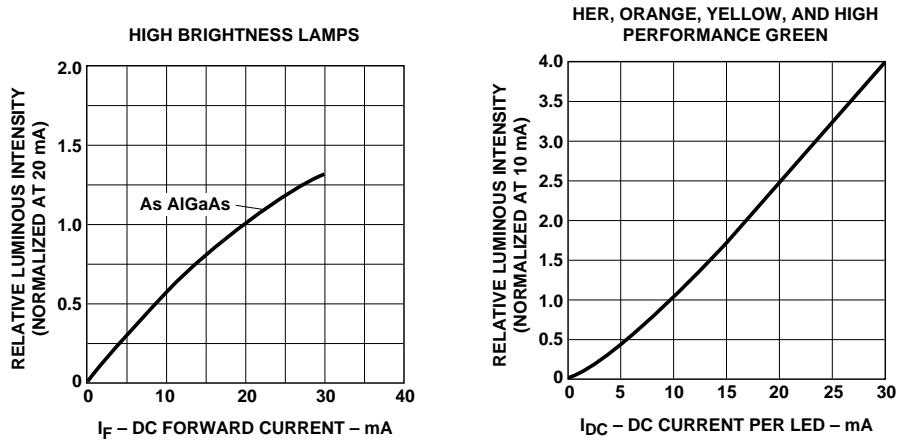

Figure 3. Relative Luminous Intensity vs. Forward Current.

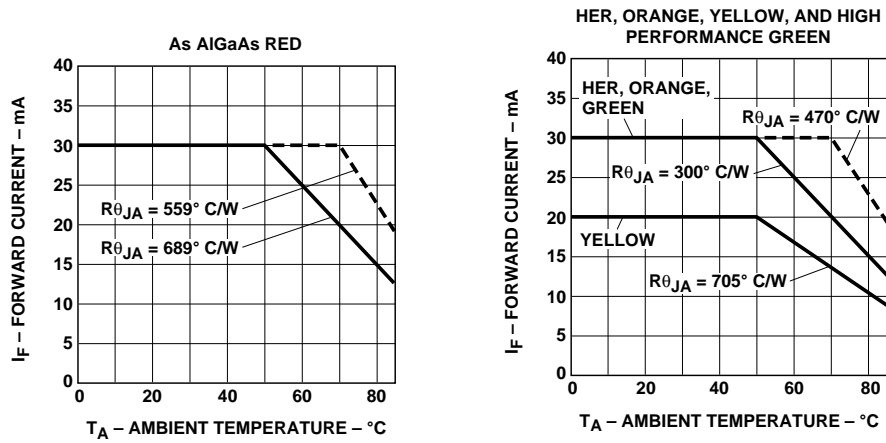

Figure 4. Maximum Forward DC Current vs. Ambient Temperature.

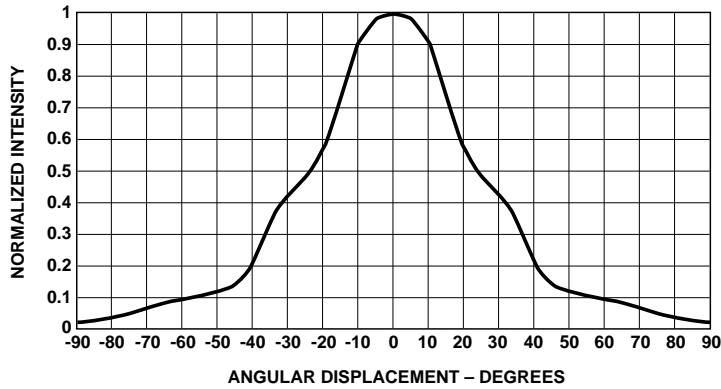

Figure 5. Representative Spatial Radiation Pattern for 45° Viewing Angle.

Taping Options

Option	Straight Lead		
	#002	#2CA	#2CD
Dimension "B"	-	-	-
Dimension "H"	20.5 ± 1.0 (0.81 ± 0.04)	18.0 ± 1.0 (0.71 ± 0.04)	20.5 ± 1.0 (0.81 ± 0.04)

Units: mm (inches)

Tape Outline Drawing

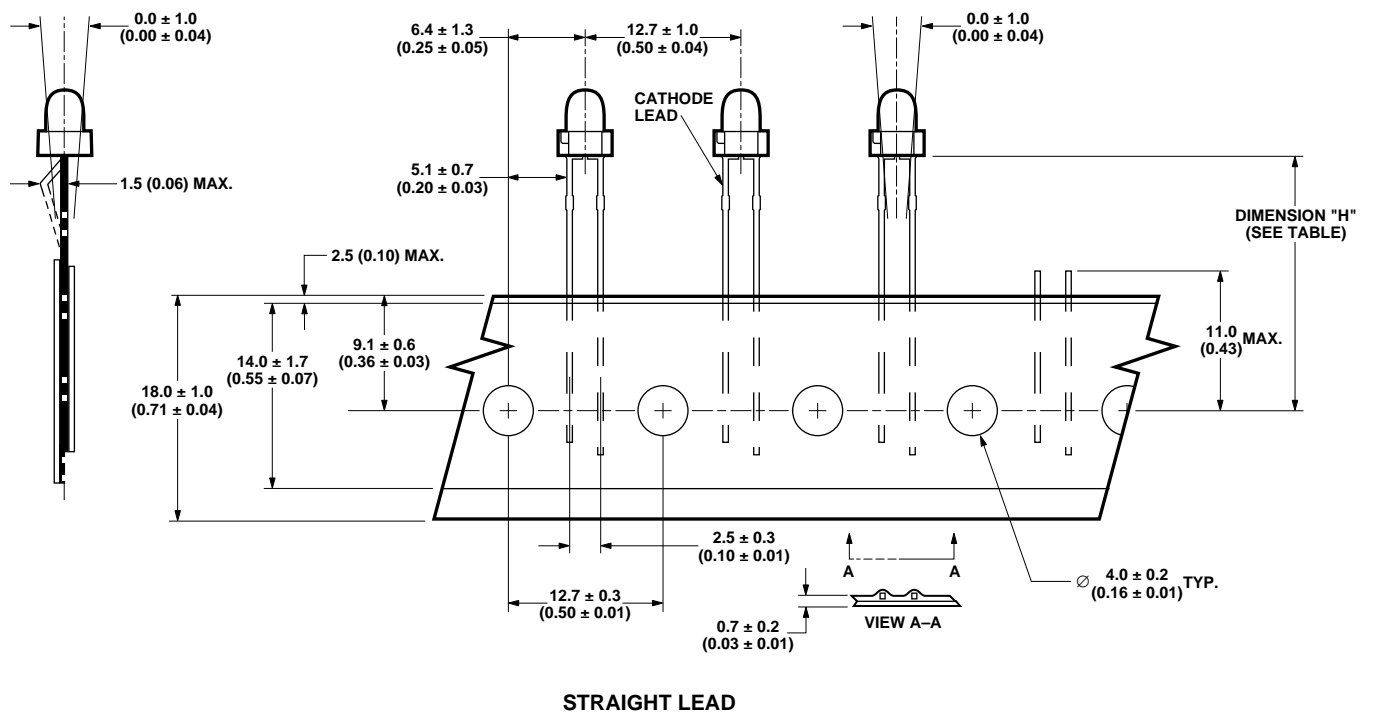

Package Options

Lead Option	Ammo Pack (1000 pcs.)	Tape & Reel (2000 pcs.)
Straight Lead	#2C —	#002

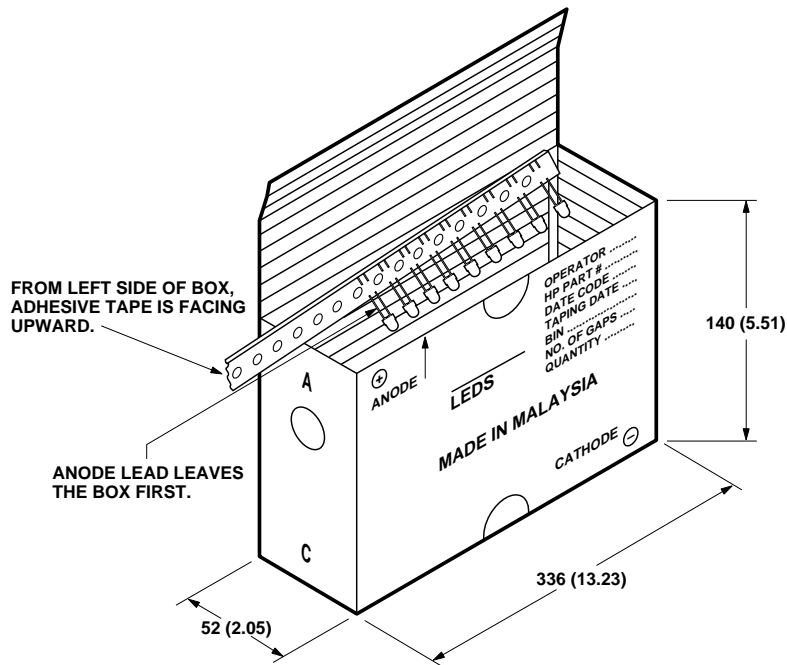

DIMENSIONS IN MILLIMETERS (INCHES).

AMMO PACK (for All options except #002)

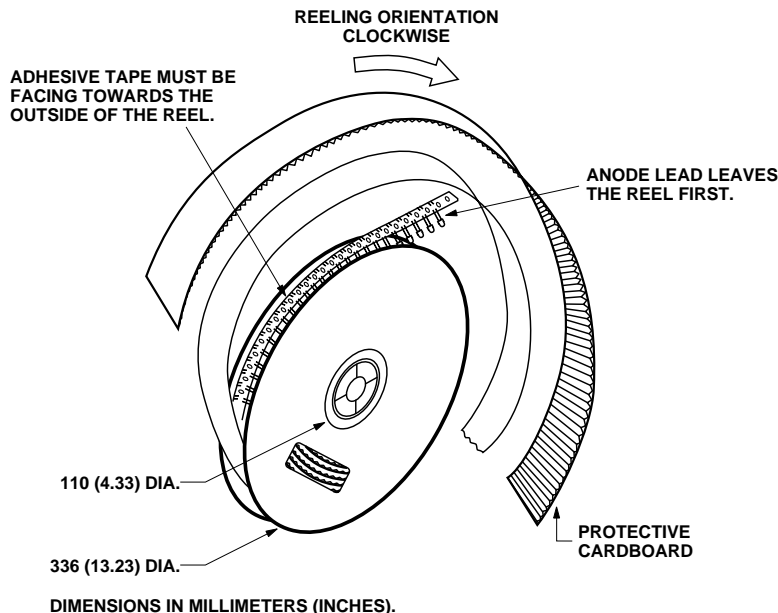

DIMENSIONS IN MILLIMETERS (INCHES).

TAPE & REEL (for option #002 only)

Recommended Assembly Condition

- A single-sided phenolic printed circuit board (PCB) is preferred. Double-sided PCB and other materials may cause greater lead stress. Recommended through-hole diameter is 0.9 to 2.0 mm. Leadlength below the PCB should be 1.5 to 2.0 mm, and the clinching angle (angle between the lead and PCB) should be 30 ± 10 degrees.

- If SMT devices and an adhesive are used on the same pcb as these lamps, the adhesive should be cured before the lamps are auto-inserted. If curing must be done after lamp insertion, the cure temperature and time should not exceed 140°C , 100 seconds. This is the temperature of the surface normal to the IR source.

Solder Condition:

Preheat: Temperature ramp rate of 2 to 4°C per second. Do not exceed 150°C delta temperature between preheat and solder temperatures. The maximum time at preheat should not exceed 10 seconds.

Solder: 245°C maximum, 3 seconds (1.6 mm below seating plane).

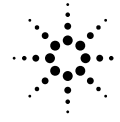

Agilent Technologies
Innovating the HP Way

www.semiconductor.agilent.com

Data subject to change.
Copyright © 1999 Agilent Technologies, Inc.
5968-4402E (11/99)