

CMOS VOLTAGE DETECTOR

DESCRIPTION

The SCI7700Y Series/SCI7701Y Series are a series of low-power precision voltage detectors, which do not require external adjustments. The SCI7700Y Series/SCI7701Y Series have such applications as battery-life detection, power supply fault monitoring, over/under-voltage protection and battery back-up switching. The SCI7700Y Series is an open-drain Nch output type and the SCI7701Y Series is a CMOS output type. Both are available in SOT 89-3pin (plastic) packages.

FEATURES

- Many types see the next page
- Low operating supply current Typ 1.8 μ A (SCI7700YNA, V_{DD}=3.0V)
- Low range of operating voltage Typ 1.2V (SCI7700YNA)
- Temperature coefficient of detection voltage Typ (detection voltage/reference voltage) x 0.1 (mV/°C)
- Hysteresis difference Typ detection voltage x 0.05V
- Package SOT 89-3pin (plastic)

BLOCK DIAGRAM

● SCI7700Y Series

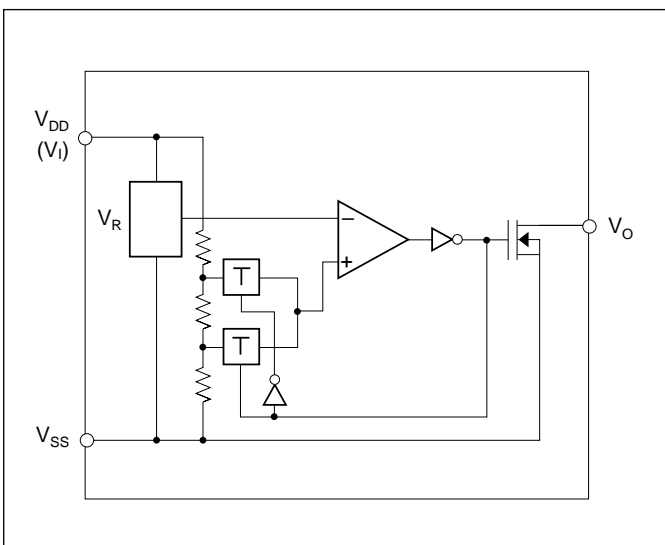

● SCI7701Y Series

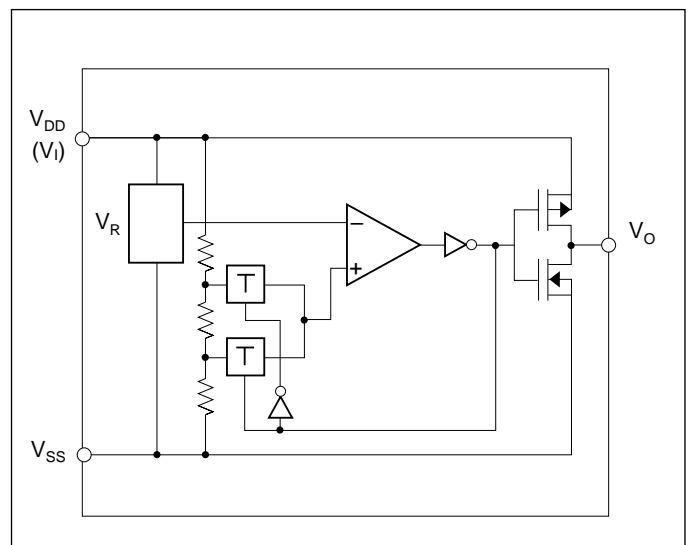

November 1996

■ PIN CONFIGURATION

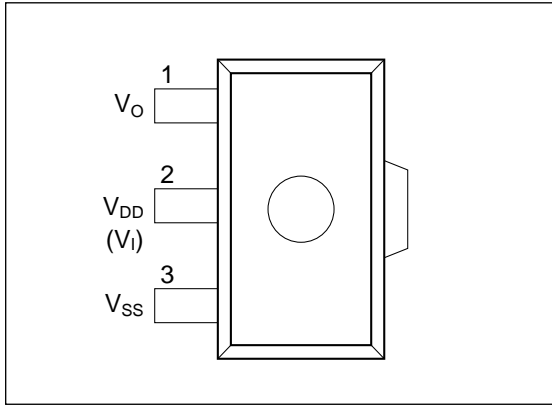

(Ta = 25°C)

Type No.	Output Mode	Detection Voltage (V)			Operating Voltage (V)	Operating Supply Current (μA)
		Min	Typ	Max		
SCI7700YVA	Open drain Nch	0.90	0.95	1.00	0.8 to 5.0	Typ 1.4 (VDD=1.5V)
SCI7700YAA	Open drain Nch	1.00	1.05	1.10	0.9 to 5.0	Typ 1.4 (VDD=1.5V)
SCI7700YAS	Open drain Nch	1.05	1.10	1.15	0.8 to 10.0	Typ 1.4 (VDD=1.5V)
SCI7700YBA	Open drain Nch	1.10	1.15	1.20	0.9 to 5.0	Typ 1.4 (VDD=1.5V)
SCI7700YNA	Open drain Nch	1.85	1.90	1.95	1.2 to 10.0	Typ 1.8 (VDD=3.0)
SCI7700YCA	Open drain Nch	2.10	2.15	2.20	0.9 to 5.0	Typ 1.8 (VDD=3.0V)
SCI7700YFA	Open drain Nch	2.60	2.70	2.80	1.5 to 10.0	Typ 1.8 (VDD=3.0V)
SCI7700YTA	Open drain Nch	3.80	4.00	4.20	1.5 to 10.0	Typ 2.6 (VDD=6.0V)
SCI7701YCA	CMOS	2.10	2.15	2.20	1.5 to 10.0	Typ 1.8 (VDD=3.0V)
SCI7701YCB*						
SCI7701YPA	CMOS	2.20	2.25	2.30	1.5 to 10.0	Typ 1.8 (VDD=3.0V)
SCI7701YSA	CMOS	2.30	2.35	2.40	1.5 to 10.0	Typ 1.8 (VDD=3.0V)
SCI7701YEA	CMOS	2.50	2.55	2.60	1.5 to 10.0	Typ 1.8 (VDD=3.0V)
SCI7701YFA	CMOS	2.60	2.70	2.80	1.5 to 10.0	Typ 1.8 (VDD=3.0V)
SCI7701YFB*						
SCI7701YRA	CMOS	2.70	2.80	2.90	1.5 to 10.0	Typ 1.8 (VDD=3.0V)
SCI7701YGA	CMOS	2.90	3.00	3.10	1.5 to 10.0	Typ 2.2 (VDD=4.5V)
SCI7701YHA	CMOS	3.10	3.20	3.30	1.5 to 10.0	Typ 2.2 (VDD=4.5V)
SCI7701YTA	CMOS	3.80	4.00	4.20	1.5 to 10.0	Typ 2.6 (VDD=6.0V)
SCI7701YMA	CMOS	4.00	4.15	4.30	1.5 to 10.0	Typ 2.6 (VDD=6.0V)
SCI7701YJA	CMOS	4.30	4.45	4.60	1.5 to 10.0	Typ 2.6 (VDD=6.0V)
SCI7701YKA	CMOS	4.60	4.75	4.90	1.5 to 10.0	Typ 2.6 (VDD=6.0V)
SCI7701YLA	CMOS	4.90	5.10	5.30	1.5 to 10.0	Typ 2.6 (VDD=6.0V)

* Reverse output polarity

■ **ABSOLUTE MAXIMUM RATINGS**

Parameter	Symbol	Ratings	Unit
Input voltage (supply voltage)	VDD (VI) – VSS	12	V
Output voltage	VO	VDD + 0.3 to VSS – 0.3	V
Output current	IO	50	mA
Power dissipation (TA ≤ 25°C)	PD	400	mW
Operating temperature	Topr	–30 to 85	°C
Storage temperature	Tstg	–65 to 150	°C
Soldering temperature and time	Tsol	260°C, 10s (at lead)	—

Note: Although this IC has electrostatic protection circuit, damage may still occur if very high electrostatic potentials are applied.

Note: When this IC is soldered in the solder-reflow process, be sure to maintain the reflow furnace at the curve shown in “Fig. 3–5 Reflow Furnace Temperature Curve” of DATA BOOK. This IC cannot be exposed to the high temperature of the the solder dipping.

November 1996

■ ELECTRICAL CHARACTERISTICS

● SCI7700YSeries/SCI7701YSeries

Parameter	Symbol	Conditions	Min	Typ	Max	Unit
Detection voltage	V _{DET}	T _a =25°C	See page 2			V
Operating supply current	I _{DDO}	V _{DD} =1.5V, T _a =25°C	—	1.4	3.0	μA
		V _{DD} =3.0V, T _a =25°C	—	1.8	4.0	
		V _{DD} =4.5V, T _a =25°C	—	2.2	5.0	
		V _{DD} =6.0V, T _a =25°C	—	2.6	6.0	
Supply (Operating) voltage	V _{DD} (V _I)	T _a =-30 to 85°C	See page 2			V
Hysteresis difference	ΔV _{DET}	T _a =-30 to 85°C	—	V _{DET} x0.05*	—	V
Temperature coefficient of V _{DET}	$\frac{V_{DET}(T_a=70^\circ C)-V_{DET}(T_a=-20^\circ C)}{90}$	T _a =-30 to 85°C	Typ(V _{DET} /V _R)x0.1			mV/°C
	90					

* V_{DET} x 0.04 (Typ) about SCI7700Y_{TA}/SCI7701Y_{TA}/SCI7701Y_{MA}/SCI7701Y_{JA}/SCI7701Y_{KA}/SCI7701Y_{LA}

● SCI7700Y_{VA}/SCI7700Y_{AA}/SCI7700Y_{BA}

Parameter	Symbol	Conditions	Min	Typ	Max	Unit
Output current		V _{DD} = 0.85V, V _{DS} = 0.5V, T _a = 25°C	0.05	0.40	1.00	mA
	I _O (Nch)	V _{DD} = 0.95V, V _{DS} = 0.5V, T _a = 25°C	0.15	0.70	1.50	
		V _{DD} = 1.05V, V _{DS} = 0.5V, T _a = 25°C	0.30	1.00	2.00	
Reference voltage supply	V _R	T _a = 25°C	0.70	0.80	0.90	V

V_{DS}: Voltage between drain and source

■ ELECTRICAL CHARACTERISTICS (Cont.)

- SCI7700YNA/SCI7700YTA/SCI7701YCA/SCI7701YPA/SCI7701YSA/SCI7701YEA/SCI7701YFA/
SCI7701YRA/SCI7701YGA/SCI7701YHA/SCI7701YTA/SCI7701YMA/SCI7701YJA/SCI7701YKA/
SCI7701YLA

Parameter	Symbol	Conditions	Min	Typ	Max	Unit
Output current	Io (Nch)	VDD=0.95V, VDS=0.5V, Ta=25°C	0.03	0.15	0.50	mA
		VDD=1.00V, VDS=0.5V, Ta=25°C	0.05	0.22	0.60	
		VDD=1.20V, VDS=0.5V, Ta=25°C	0.30	0.70	1.50	
		VDD=2.40V, VDS=0.5V, Ta=25°C	1.40	2.00	2.30*1	
		VDD=3.60V, VDS=0.5V, Ta=25°C	1.50	2.30	2.60*2	
	Io (Pch)	VDD=4.50V, VDS=2.1V, Ta=25°C	1.7	2.0	2.3	
		VDD=8.00V, VDS=2.1V, Ta=25°C	2.8	3.1	3.8	
Reference voltage supply	VR	Ta=25°C	0.90	1.00	1.10	V

- * 1: 3.30 mA about SCI7700YTA, * 2: 4.00 mA about SCI7700TA Vds: Voltage between drain and source
- * Please inquire IC sales department about SCI7700YCA.

- SCI7700YAS/SCI7700YFA/SCI7701YCB/SCI7700YFB

Parameter	Symbol	Conditions	Min	Typ	Max	Unit
Output current	Io (Nch)	VDD=0.8V, VOUT=0.1V, Ta=25°C*1	0.01	—	—	mA
		VDD=2.4V, VOUT=0.5V, Ta=25°C*2	1.7	2.5	3.3	
		VDD=2.4V, VOUT=0.5V, Ta=25°C*3	1.4	1.8	2.3	
		VDD=3.0V, VOUT=0.5V, Ta=25°C*4	1.5	2.0	2.5	
	Io (Pch)	VDD=2.0V, VOUT=1.5V, Ta=25°C*3	0.1	0.3	0.9	
		VDD=2.0V, VOUT=1.5V, Ta=25°C*4	0.1	2.0	2.5	
Reference voltage supply	VR	Ta=25°C*1	0.7	0.8	0.9	V
		Ta=25°C*2,*3,*4	0.9	1.0	1.1	

- * 1: Applicable to SCI7700YAS
- * 2: Applicable to SCI7700YFA
- * 3: Applicable to SCI7701YCB
- * 4: Applicable to SCI7701YFB

November 1996

■ PERFORMANCE CURVES

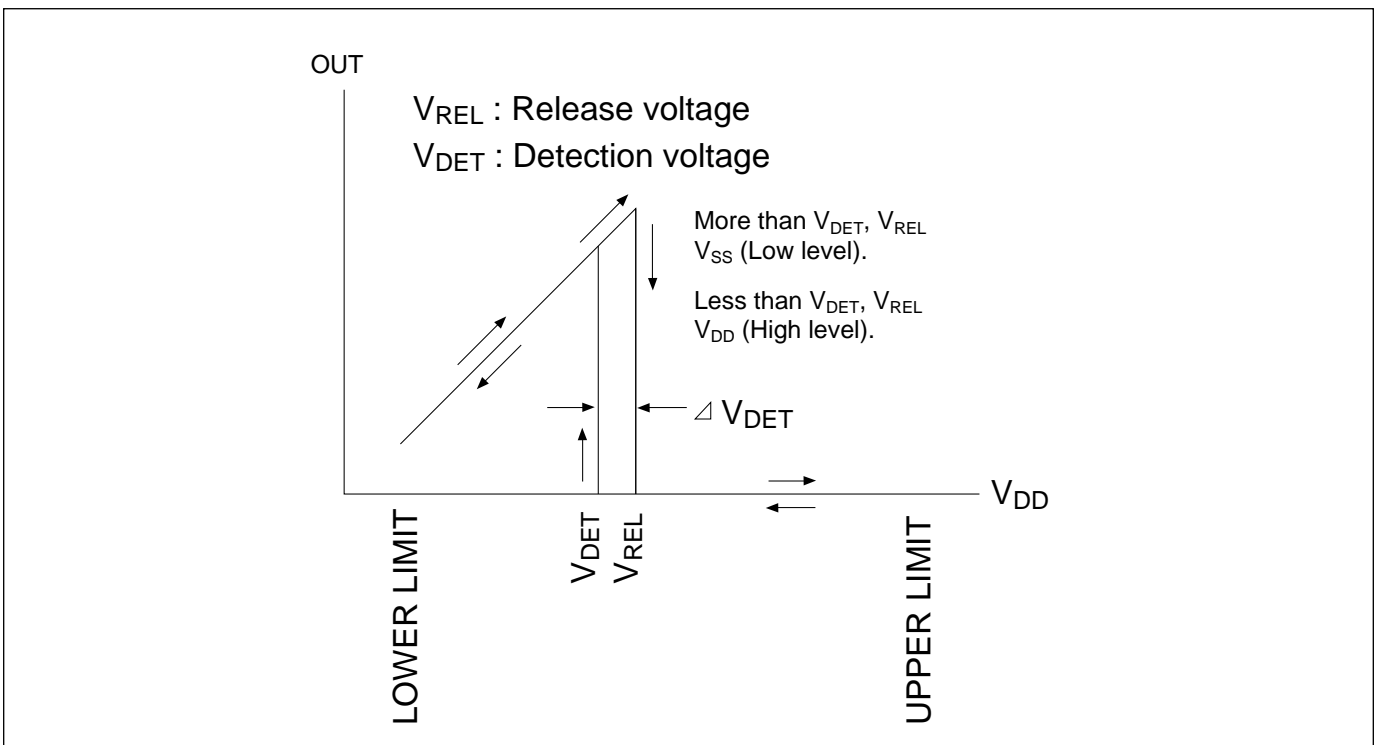
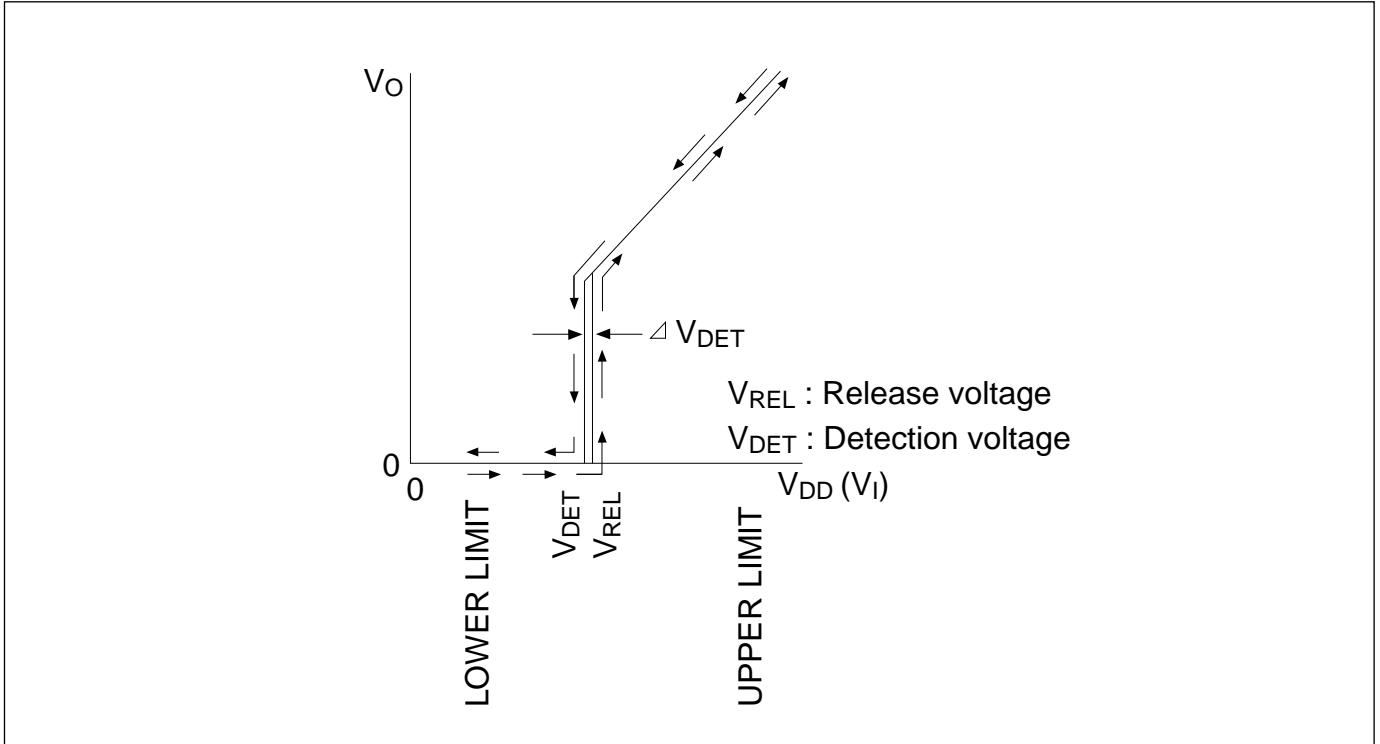

■ **MARKING**

An abbreviation is printed on SCI7700Yseries/SCI7701Yseries below, because its package size is very small.

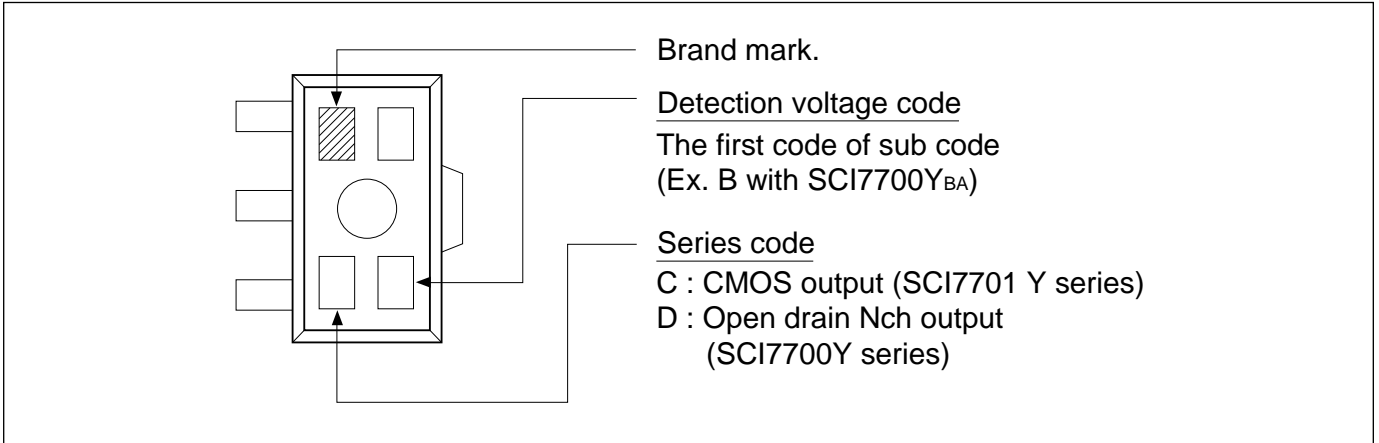

■ **PACKAGE DIMENSIONS**

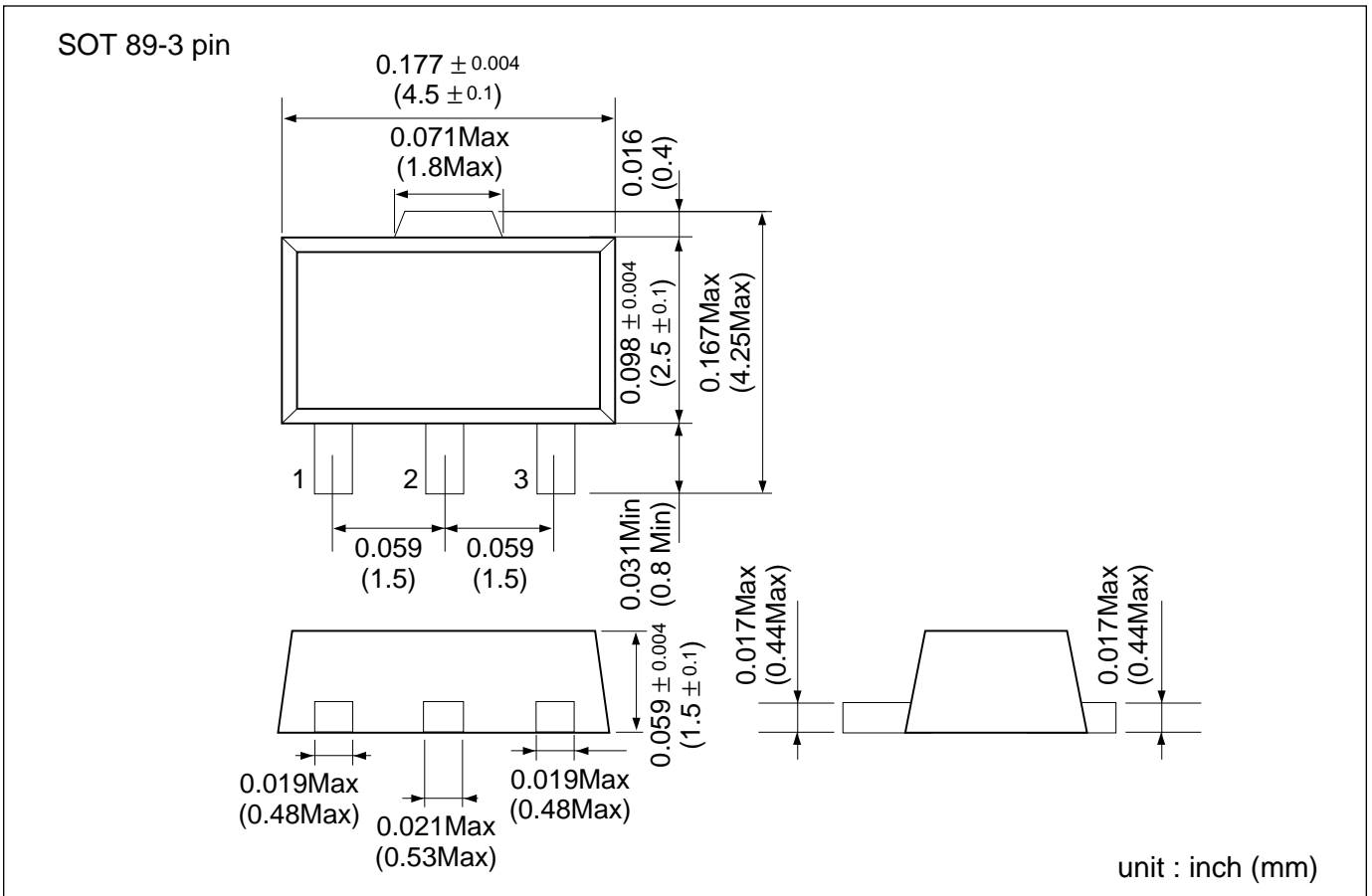

November 1996

West Coast S-MOS Systems, Inc. 150 River Oaks Parkway San Jose, CA 95134 Tel. (408) 922-0200 Fax (408) 922-0238	North East and North Central S-MOS Systems, Inc. 301 Edgewater Place, Suite 120 Wakefield, MA 01880 Tel. (617) 246-3600 Fax (617) 246-5443	South East and South Central S-MOS Systems, Inc. 4300 Six Forks Road, Suite 430 Raleigh, NC 27609 Tel. (919) 781-7667 Fax (919) 781-6778	More info... World Wide Web: http://www.smos.com
---	--	--	---

S-MOS assumes no responsibility or liability for (1) any errors or inaccuracies contained in the information herein and (2) the use of the information or a portion thereof in any application, including any claim for (a) copyright or patent infringement or (b) direct, indirect, special or consequential damages. There are no warranties extended or granted by this document. The information herein is subject to change without notice from S-MOS.