



Features

- Wideband Performance
- P_{OUT}= +4.0dBm Typical
- External Resonator Not Required
- Single Bias Supply: +5V at 53mA
- Output Phase Noise: -99dBc/Hz at 100kHz
- Low Profile 4mmx4mm QFN
- RoHS Compliant

Applications

- Military - Radar, Communications, ECM/IED
- Satcomm - Communication Modems
- Test Instrumentation
- Industrial/Medical Equipment

Frequency and Output Power versus V_{TUNE}
(V_S=5V, T=25 °C)

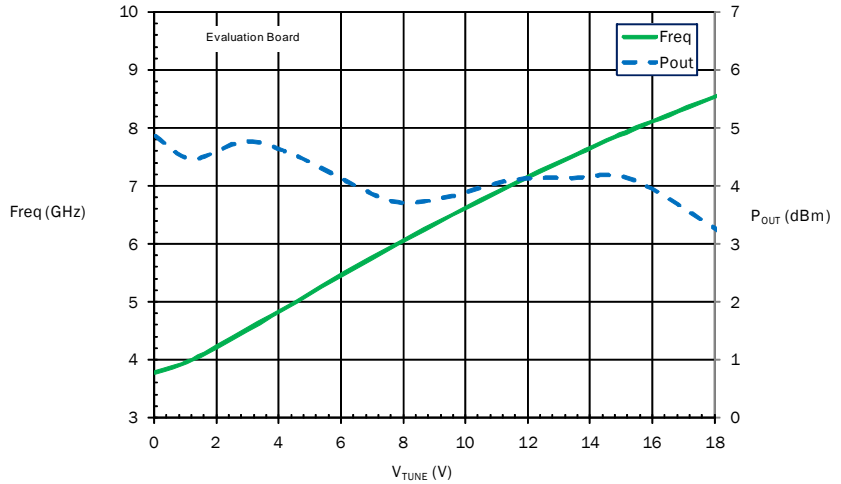

Functional Block Diagram

Product Description

RFMD's RFVC1802 wideband Voltage Controlled Oscillator is a GaAs InGaP HBT MMIC with integrated VCO core and RF output buffer. The part operates from a single +5V supply for circuit bias and 0V to +18V V_{TUNE} for frequency control. The RFVC1802 is a RoHS Compliant, compact QFN, 4mmx4mm package that offers low phase noise and low power consumption.

Ordering Information

RFVC1802S2	2 pc Sample Bag
RFVC1802PCK-410	Fully Assembled Evaluation Board
RFVC1802	5 pcs or more

Optimum Technology Matching® Applied

- | | | | |
|---|--------------------------------------|-------------------------------------|------------------------------------|
| <input type="checkbox"/> GaAs HBT | <input type="checkbox"/> SiGe BiCMOS | <input type="checkbox"/> GaAs pHEMT | <input type="checkbox"/> GaN HEMT |
| <input type="checkbox"/> GaAs MESFET | <input type="checkbox"/> Si BiCMOS | <input type="checkbox"/> Si CMOS | <input type="checkbox"/> BiFET HBT |
| <input checked="" type="checkbox"/> InGaP HBT | <input type="checkbox"/> SiGe HBT | <input type="checkbox"/> Si BJT | <input type="checkbox"/> LD MOS |

RF MICRO DEVICES®, RFMD®, Optimum Technology Matching®, Enabling Wireless Connectivity™, PowerStar®, POLARIS™ TOTAL RADIO™ and UltimateBlue™ are trademarks of RFMD, LLC. BLUETOOTH is a trademark owned by Bluetooth SIG, Inc., U.S.A. and licensed for use by RFMD. All other trade names, trademarks and registered trademarks are the property of their respective owners. ©2006, RF Micro Devices, Inc.

Absolute Maximum Ratings

Parameter	Rating	Unit
Device Operating Voltage (V_S)	5.5	V
V_{TUNE} (V_T)	0 to +20	V
Device Operating Current	80	mA
Operating Temperature Range	-40 to +85	°C
Storage Temperature Range	-65 to +150	°C
Operating Junction Temperature (T_J)	+140	°C
ESD Rating - Human Body Model (HBM)	Class 0	



Caution! ESD sensitive device.

Exceeding any one or a combination of the Absolute Maximum Rating conditions may cause permanent damage to the device. Extended application of Absolute Maximum Rating conditions to the device may reduce device reliability. Specified typical performance or functional operation of the device under Absolute Maximum Rating conditions is not implied.

RoHS status based on EUDirective2002/95/EC (at time of this document revision).

The information in this publication is believed to be accurate and reliable. However, no responsibility is assumed by RF Micro Devices, Inc. ("RFMD") for its use, nor for any infringement of patents, or other rights of third parties, resulting from its use. No license is granted by implication or otherwise under any patent or patent rights of RFMD. RFMD reserves the right to change component circuitry, recommended application circuitry and specifications at any time without prior notice.

Parameter	Specification			Unit	Condition
	Min.	Typ.	Max.		
Overall					$V_S = 5V$, Freq = 4GHz to 8GHz, $T = 25^\circ C$ unless noted otherwise.
Frequency of Operation	4.0		8.0	GHz	
Supply Voltage (V_S)	4.75	5.00	5.25	V	Recommended operating range
Supply Current	40	53	70	mA	
Tuning Voltage (V_{TUNE})	0		18	V	
Tuning Sensitivity		270		MHz/V	
Output Power		4.0		dBm	
Output Phase Noise at 10kHz		-74		dBc/Hz	
Output Phase Noise at 100kHz		-99		dBc/Hz	
2nd Harmonic		-20		dBc	
Frequency Pushing		15		MHz/V	
Frequency Pulling (2:1 VSWR)		3		MHz pp	
RF Output Return Loss		10		dB	
Frequency Drift Rate		-0.6		MHz/°C	
V_{TUNE} Port Input Capacitance		4		pF	
Thermal Resistance		45		°C/W	Junction to paddle

Typical Evaluation Board Performance ($V_S = 5.0V$ unless otherwise noted)

Supply Current versus V_{TUNE}

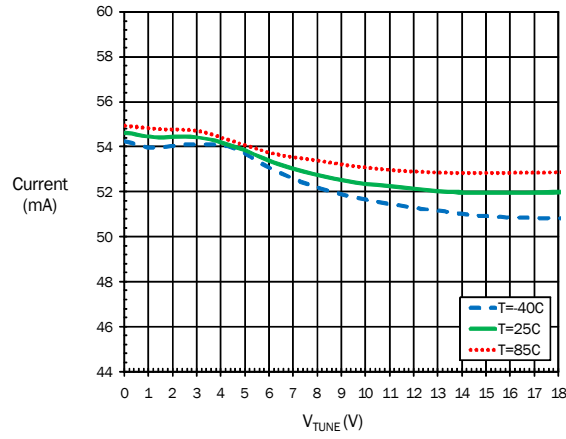

Typical Evaluation Board Performance ($V_S = 5.0V$ unless otherwise noted)

Frequency versus V_{TUNE}

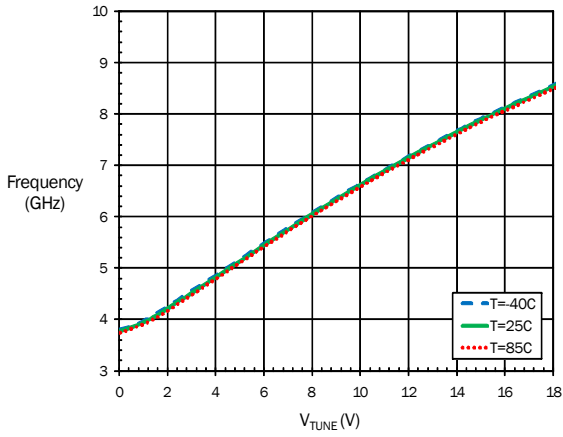

Output Power versus V_{TUNE}

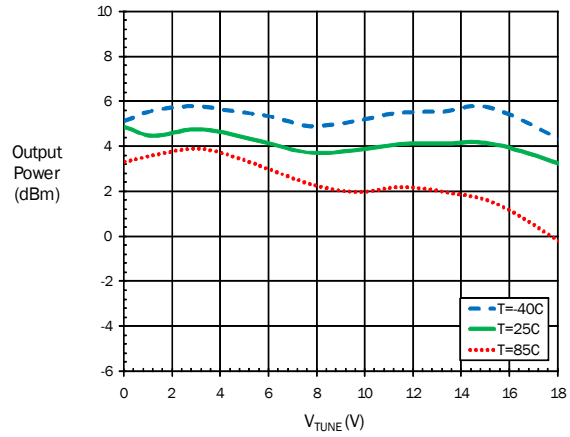

Phase Noise at 10kHz Offset versus Frequency

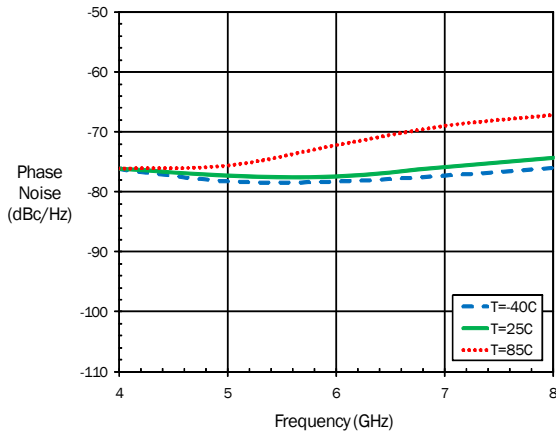

Phase Noise at 100kHz Offset versus Frequency

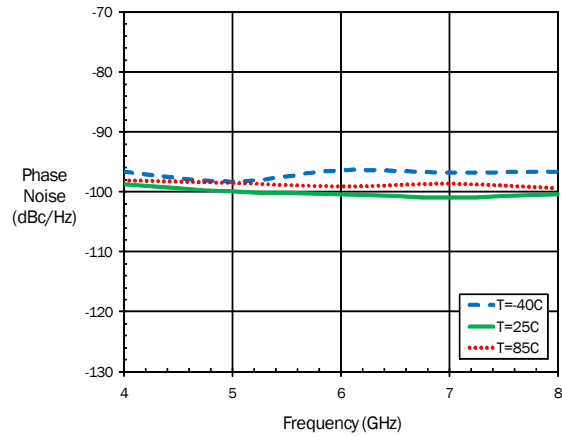

Modulation Sensitivity versus Frequency

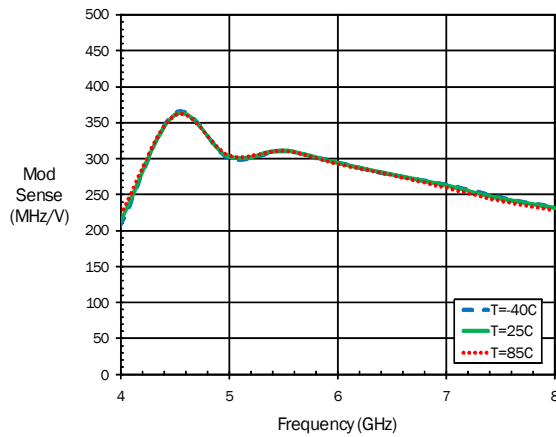

Pushing versus Frequency

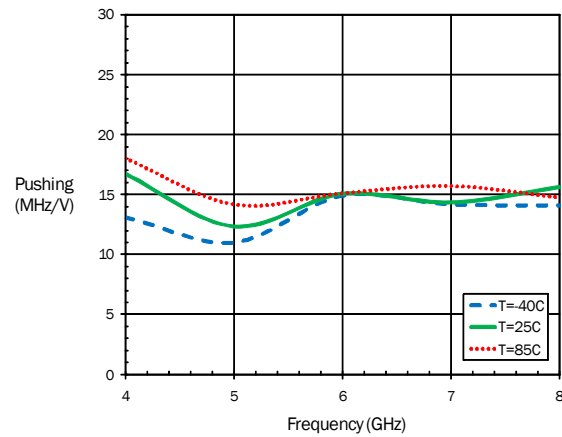

Pin	Function	Description
1-3, 5-11, 13, 17-24	NC	No internal connection. Connect to PCB ground.
4	VTUNE	VCO control voltage input
12	VS	Supply voltage input for the VCO and Buffer stage.
14,16	GND	Pin internally bonded to package paddle. Connect to PCB ground.
15	RFOUT	VCO RF output. Pin is internally DC-blocked.
Pad- dle	GND	Exposed paddle on backside needs to be soldered to PCB ground.

Pin Out

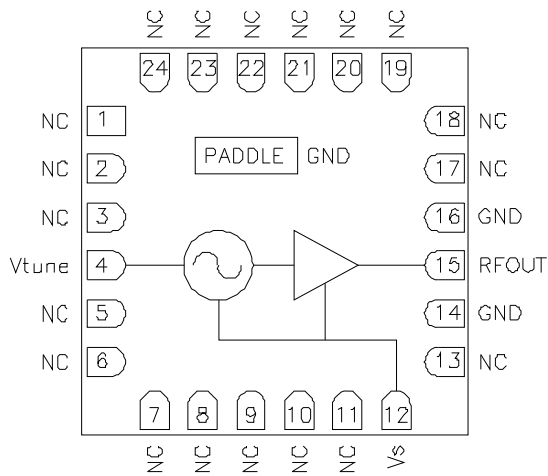

Evaluation Board Schematic

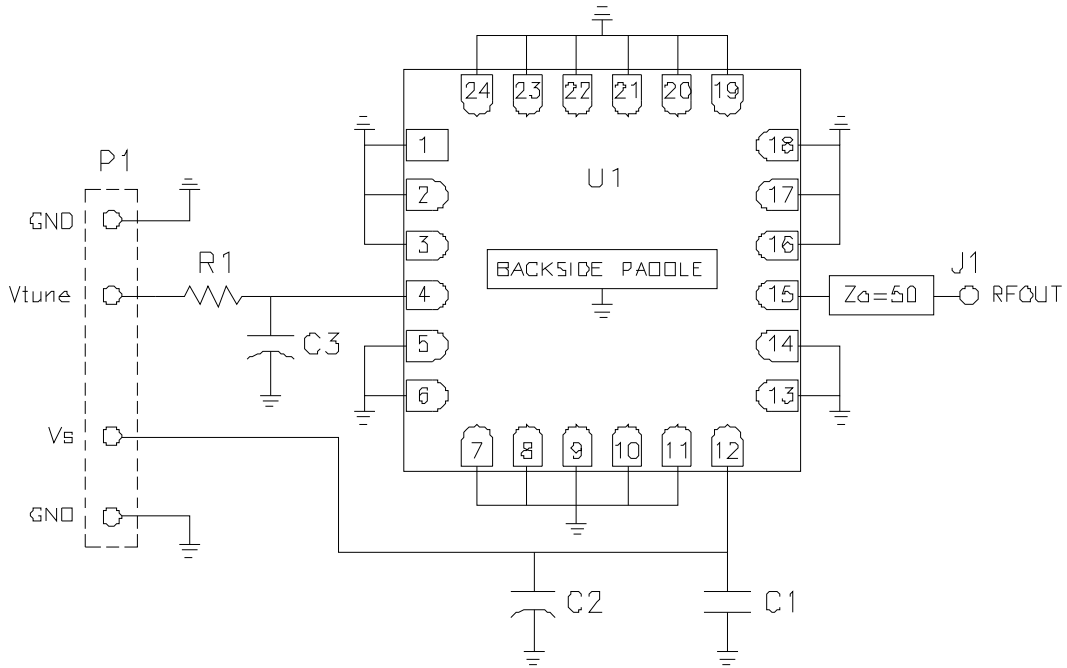

Item	Description
U1	RFVC1802
C1	CAP, 1000pF, 0402
C2	CAP, 4.7 uF, TANT-A
C3	CAP, 22 uF, TANT-D
R1	Jumper, 0Ω, 0402
P1	CONN, HDR, ST, PLRZD, 4-Pin, 0.100"
J1	CONN, SMA, END Launch

Evaluation Board Layout

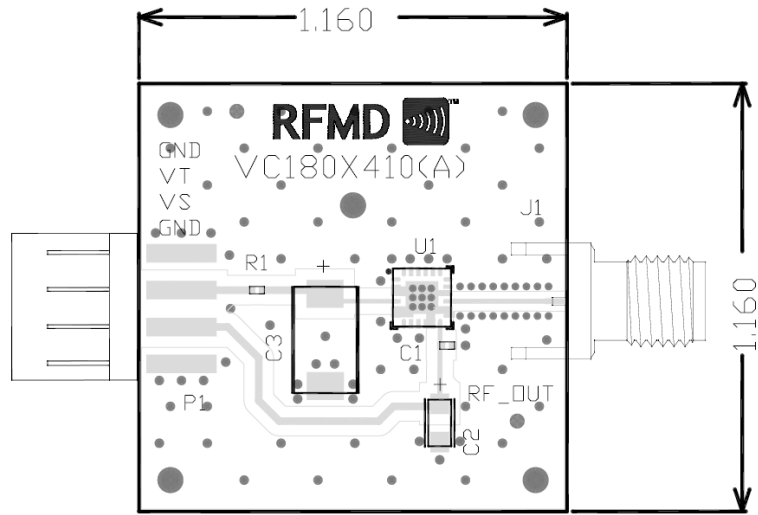

Package Drawing

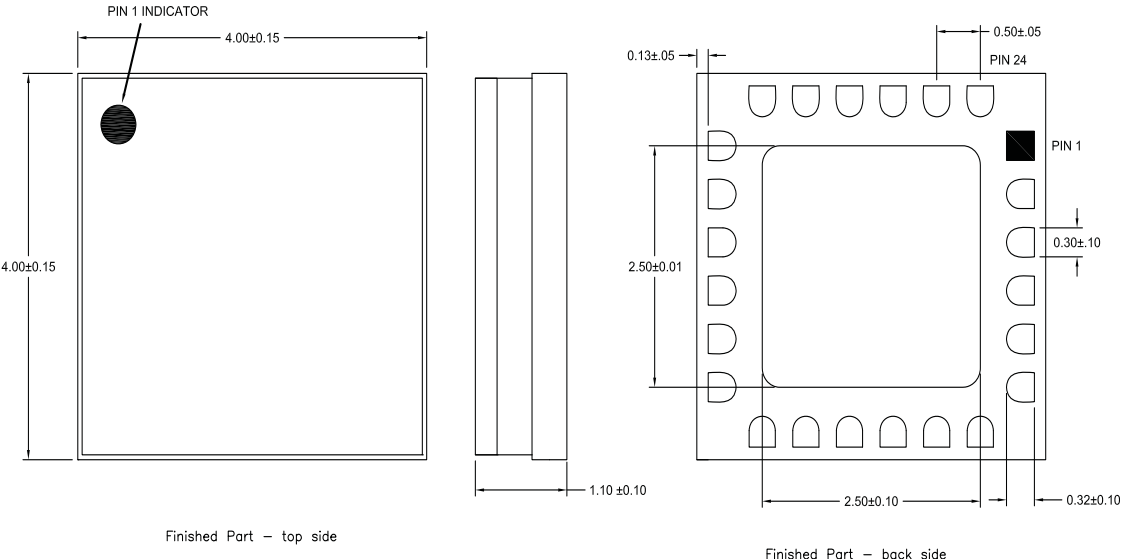

- Notes:
- 1. Dimensions in mm.
 - 2. Dimensions are for reference only.
 - 3. Package body material: Alumina.
 - 4. Lead and Paddle plating: Gold.