

EnerChip™ CC CBC3112 & CBC3150 Evaluation Kit

Overview

The EnerChip CC EVAL-05 Evaluation Kit is used to demonstrate the capabilities of the EnerChip Thin Film Batteries and the EnerChip CC with Integrated Battery Management capabilities. The kit can be used to demonstrate: 1) either EnerChip battery, 2) either EnerChip CC device or 3) the EnerChip CC in parallel with the other EnerChip battery.

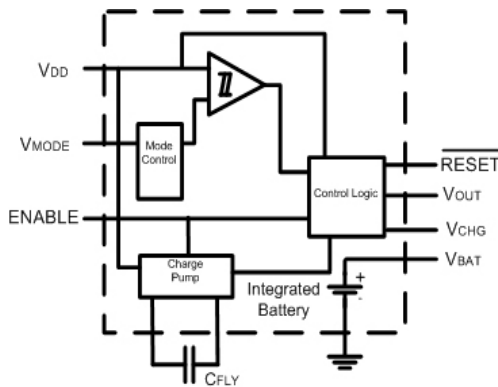

Figure 1: EnerChip CC Block Diagram

EnerChip CC Applications

- **Standby supply** for non-volatile SRAM, real-time clocks, controllers, supply supervisors, and other system-critical components.
- **Wireless sensors and RFID tags** and other powered, low duty cycle applications.
- **Localized power source** to keep microcontrollers and other devices alert in standby mode.
- **Power bridging** to provide back-up power to system during exchange of main batteries.
- **Consumer appliances** that have real-time clocks; provides switchover power from main supply to backup battery.
- **Business and industrial systems** such as: network routers, point-of-sale terminals, single-board computers, test equipment, multi-function printers, industrial controllers, and utility meters
- **Energy Harvesting** by coupling the EnerChip with energy transducers such as solar panels.

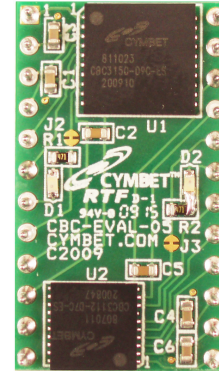

Figure 2: EnerChip CC Evaluation Module

Evaluation Kit Description

The EnerChip CC is the world's first Intelligent Thin Film Battery. It is an integrated solution that provides battery backup and power management for systems requiring power bridging and/or secondary power. A single EnerChip CC can charge up to 10 additional EnerChips connected in parallel.

Two EnerChip CC devices are on the EVAL-05, a CBC3112 and a CBC3150, with battery capacities of 12 μ Ah and 50 μ Ah, respectively. The CBC-EVAL-05 evaluation board utilizes a 24-pin DIP format that mates with a 24-pin DIP socket on a target board.

During normal operation, the EnerChip CC charges itself with a controlled voltage using an internal charge pump that operates from 2.5V to 5.5V. An ENABLE pin allows the designer to activate and deactivate the charge pump using an external control line in order to minimize current consumption and take advantage of the fast recharge time of the EnerChip.

When the primary power supply dips below a user-defined threshold voltage, the EnerChip CC will signal this event and route the battery voltage to Vout. The EnerChip CC also has battery protection circuitry to enable thousands of recharge cycles.

The CBC3112 and CBC3150 data sheets contain complete specifications and application circuits.

CBC-EVAL-05 Input/Output Descriptions and Pin-outs

Pin Number	Label	Description
1	VBAT	Positive Battery Terminal - Tie to Pin 4 ⁽¹⁾
2	VOUT	System Voltage
3	VDD	Input Voltage
4	VCHG	Battery Charge Voltage - Tie to Pin 1 and/or Optional EnerChip(s)
5	ENABLE	Charge Pump Enable
6	VMODE	Mode Select for Battery Switchover Threshold
7	GND	System Ground
8	RESET	Reset Signal (Active Low)
9	CP	Flying Capacitor Positive
10	CN	Flying Capacitor Negative
11	No Connect	No Connection
12	No Connect	No Connection
13	VBAT	Positive Battery Terminal - Tie to Pin 16 ⁽¹⁾
14	VOUT	System Voltage
15	VDD	Input Voltage
16	VCHG	Battery Charge Voltage - Tie to Pin 13 and/or Optional EnerChip(s)
17	ENABLE	Charge Pump Enable
18	VMODE	Mode Select for Battery Switchover Threshold
19	GND	System Ground
20	RESET	Reset Signal (Active Low)
21	CP	Flying Capacitor Positive
22	CN	Flying Capacitor Negative
23	No Connect	No Connection
24	No Connect	No Connection

⁽¹⁾ See EVAL-05 Operational Modes on page 4 for optional connections to VBAT.

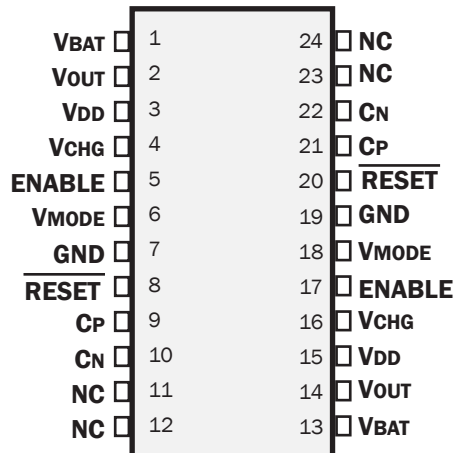

24-Pin DIP Module

CBC-EVAL-05 Dimensions	
Attribute	Size
width	0.7 in [17.18mm]
length	1.2in [30.48mm]
height	0.9in [5.00mm]



The EVAL05 module is sensitive to electrostatic discharge (ESD) and must be handled accordingly. In cases where the EVAL-05 module is removed from its original packaging, it is a requirement to maintain the same type of anti-static, non-conductive packaging to prevent discharge of the on-board EnerChips. Do not store the EVAL-05 in conductive black foam, as it will discharge and destroy the EnerChips on the module.

Evaluation Kit Schematic

The CBC-EVAL-05 board is configured symmetrically so that a single external circuit can be used to evaluate the CBC3150 when the board is plugged into the DIP socket in the pin 1 to pin 1 orientation, and the CBC3112 when the board is rotated 180 degrees. Pins 1-12 pertain to the CBC3150. Pins 13-24 pertain to the CBC3112. A circuit schematic of CBC-EVAL-05 is shown in Figure 3. Figure 4 is a typical application circuit.

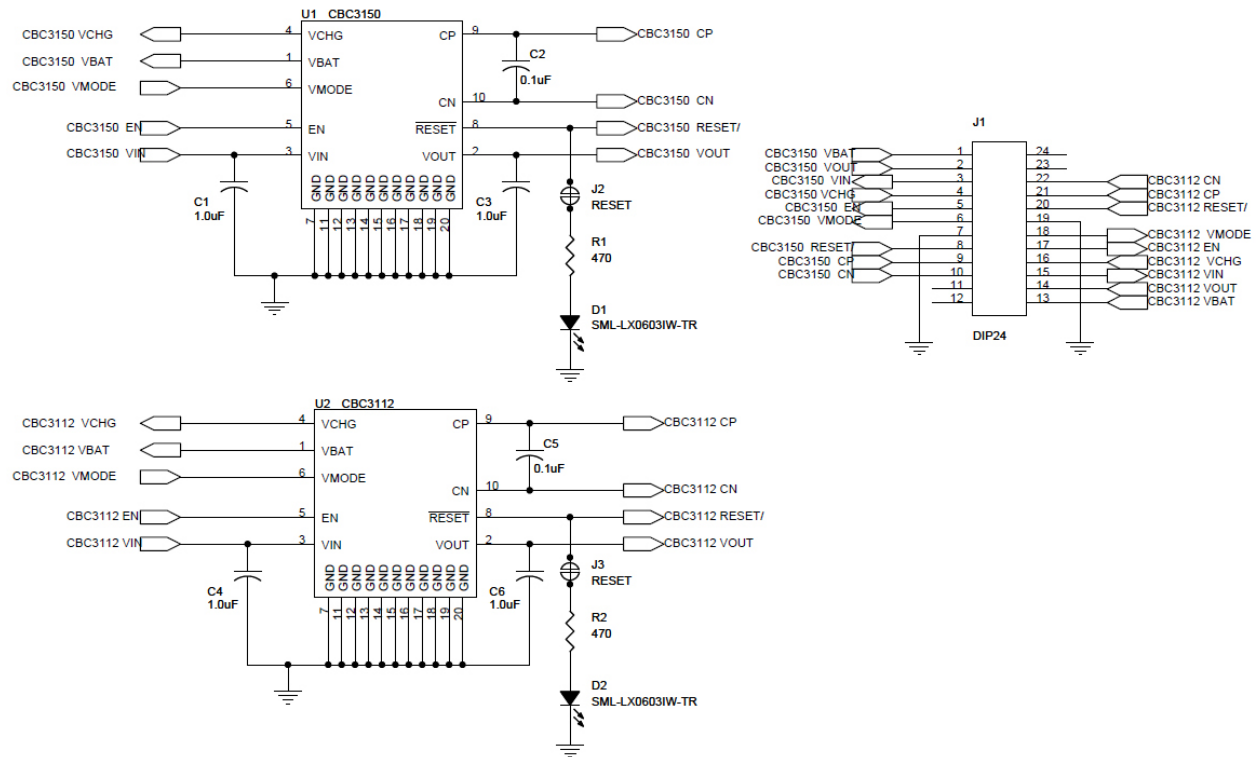

Figure 3: CBC-EVAL-05 Circuit Schematic

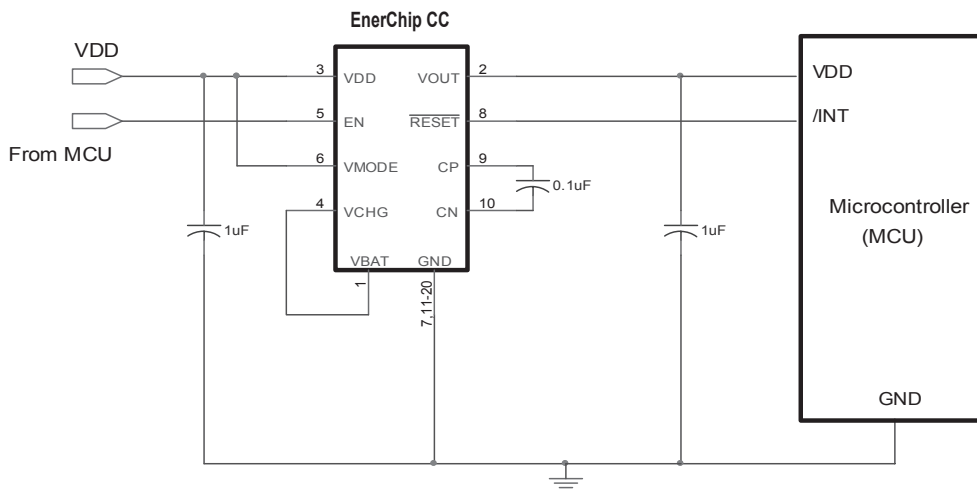

Figure 4: Typical EnerChip CC Application Circuit

EVAL-05 Operational Modes

The CBC-EVAL-05 board can be used in seven different ways:

1. CBC3150 only - Connect to pins 1-12.
2. CBC3112 only - Connect to pins 13-24 or rotate the EVAL-05 so that pin 13 is inserted into socket pin 1 and connect to pins 1-12 on EVAL-05.
3. CBC050 only - the EnerChip 50 μ Ah battery is tested alone. Do not connect pins 1 and 4 together; pin 1 is the positive EnerChip terminal and can be charged and discharged independently of the integrated battery management circuitry. See the CBC050 data sheet for EnerChip operating and use conditions.
4. CBC012 only - the Enerchip 12 μ Ah battery is tested alone. Do not connect pins 13 and 16 together; pin 13 is the positive EnerChip terminal and can be charged and discharged independently of the integrated battery management circuitry. See the CBC012 data sheet for EnerChip operating and use conditions.
5. CBC3150 controlling the CBC012 - The CBC3150 can be used to control external EnerChips, including the CBC012 embedded in the CBC3112 package on board the EVAL-05. This is accomplished by connecting pin 4 (VCHG) to pin 13 (VBAT).
6. CBC3112 controlling the CBC050 - The CBC3112 can be used to control external EnerChips, including the CBC050 embedded in the CBC3150 package on board the EVAL-05. This is accomplished by connecting pin 16 (VCHG) to pin 1 (VBAT).
7. CBC3112 and CBC3150 simultaneously - Connect the two VBAT pins (1 and 13) together and tie them to EITHER VCHG pin (not both). Leave the other VCHG disconnected from the circuit.

Using the EVAL-05

- Place the 24-pin EVAL-05 module into solderless breadboard or socket with pin 1 in pin 1.
- Note that if only one EnerChip CC is to be evaluated at a time, only pins 1 to 12 need to be connected on the test board. With board pin 1 in socket pin 1, the CBC3150 is accessible. To access the CBC3112, turn the EVAL-05 180 degrees and place EVAL-05 pin 13 in socket pin 1.
- Tie VBAT to VCHG on the test board.
- When operating under main power, LED D1 (CBC3150) or D2 (CBC3112) will be illuminated. When operating in battery backup mode, LED D1 (CBC3150) and D2 (CBC3112) will not be illuminated.
- Tie V_{MODE} to V_{DD} or GND depending the system voltage and the desired switchover voltage. Optionally, use a resistor divider. See the CBC3112 or CBC3150 datasheets for switchover voltage details.
- Tie the ENABLE pin to V_{DD}.
- Tie V_{OUT} to V_{DD} of a microcontroller or any device requiring power backup.
- Tie the $\overline{\text{RESET}}$ pin to the interrupt pin of a microcontroller if desired. When operation is under battery backup mode, the LED will not be illuminated.
- Allow the EnerChip CC to charge for at least 30 minutes before attempting to use backup power.
- Monitor VBAT for battery voltage and monitor V_{OUT} for output voltage to the system.
- Place current meter between $\overline{\text{VBAT}}$ and VCHG to monitor battery charging current if desired.
- Disconnect V_{DD} and the $\overline{\text{RESET}}$ pin will go low and system will switchover to battery backup mode.

Ordering Information

EnerChip Part Number	Description	Notes
CBC-EVAL-05	EnerChip CC Evaluation Kit	---

Disclaimer of Warranties; As Is

The information provided in this data sheet is provided "As Is" and Cymbet Corporation disclaims all representations or warranties of any kind, express or implied, relating to this data sheet and the Cymbet battery product described herein, including without limitation, the implied warranties of merchantability, fitness for a particular purpose, non-infringement, title, or any warranties arising out of course of dealing, course of performance, or usage of trade. Cymbet battery products are not approved for use in life critical applications. Users shall confirm suitability of the Cymbet battery product in any products or applications in which the Cymbet battery product is adopted for use and are solely responsible for all legal, regulatory, and safety-related requirements concerning their products and applications and any use of the Cymbet battery product described herein in any such product or applications.

Cymbet, the Cymbet logo, and EnerChip are Cymbet Corporation Trademarks