

# MX-COM, INC. MiXed Signal ICs

DATA BULLETIN

## MX429A

1200/2400bps MSK Modem  
for Trunked Radio Systems

### Features

- Band III & General Purpose Trunked Radio Apps
- Full-Duplex 1200 and 2400 Baud Operation
- Error Check Word Generation and Checking
- Preamble Generation
- $\mu$ Processor Compatible Interface
- Frame SYNC and SYNT Detection
- Low Power Consumption
- General Purpose Timer

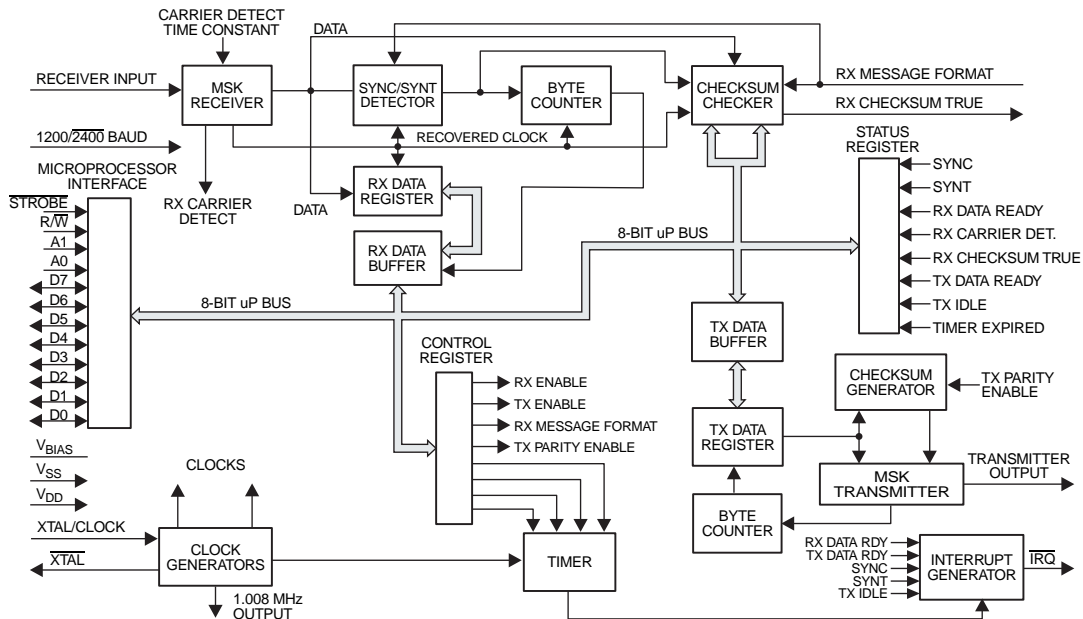

The MX429A is a single-chip CMOS 1200 and 2400 baud MSK modem, designed primarily for use in Trunked Radio Systems but may also be employed in other general purpose radio or line data communication applications. The device has been designed to conform to the UK Band III trunked radio protocols MPT 1317/1327.

The MX429A is full duplex at 1200 and 2400 baud and includes an 8-bit parallel microprocessor interface and a programmable timer which may be set for interrupt periods of 8 to 120 bits. Preamble may be generated by the device in transmit. The 16-bit SYNC or SYNT words are detected in receive. An error check word is automatically generated in transmit and error checking is performed in the receive mode. An on-chip Xtal/clock generator requiring an external 4.032MHz Xtal or clock input provides both 4.032MHz and 1.008MHz outputs and performs all modem timings.

The MX429A requires a single 5-volt power supply, has a powersave facility, and is available in the following package styles: 24-pin CDIP (MX429AJ), 24-pin PDIP (MX429AP), and 24-pin PLCC (MX429ALH).

# CONTENTS

Section	Page
<b>1 Block Diagram</b> .....	<b>3</b>
<b>2 Signal List</b> .....	<b>3</b>
<b>3 External Components</b> .....	<b>5</b>
<b>4 General Description</b> .....	<b>6</b>
4.1 Modems in Mobile Data Signaling.....	6
4.1.1 Digital Code Format.....	6
4.1.2 Operation.....	6
4.1.3 Non MPT Application – Full-Duplex.....	7
4.1.4 Control Register (A1 = 1, A0 = 1, $R/\overline{W}$ = 0, Write Only).....	7
4.1.5 Status Register (A1 = 1, A0 = 1, $R/\overline{W}$ = 1, Read Only).....	8
4.1.6 Rx Data Buffer (A1 = 1, A0 = 0, $R/\overline{W}$ = 1, Read Only).....	9
4.1.7 Tx Data Buffer (A1 = 1, A0 = 0, $R/\overline{W}$ = 0, Write Only).....	9
4.2 Syndrome Word.....	10
4.2.1 Syndrome Low Byte (A1 = 0, A0 = 0, $R/\overline{W}$ = 1, Read Only).....	10
4.2.2 Syndrome High Byte (A1 = 0, A0 = 1, $R/\overline{W}$ = 1, Read Only).....	10
4.3 Carrier Detect Time Constant.....	10
<b>5 Application</b> .....	<b>11</b>
5.1 Checksum Generation and Checking.....	11
5.2 Receive Operation.....	11
5.3 Transmit Operation.....	12
5.4 Basic Power Up Software.....	13
5.5 Basic Software Interrupt Flow.....	14
5.6 Bus Interface Timing.....	15
5.6.1 Bus interface design migration from MX429 to MX429A.....	15
<b>6 Performance Specification</b> .....	<b>15</b>
6.1 Electrical Performance.....	15
6.1.1 Absolute Maximum Ratings.....	15
6.1.2 Operating Limits.....	15
6.1.3 Operating Characteristics.....	16
6.1.4 Timing.....	18
6.2 Packaging.....	18

MX•COM, Inc. reserves the right to change specifications at any time and without notice.

## 1 Block Diagram

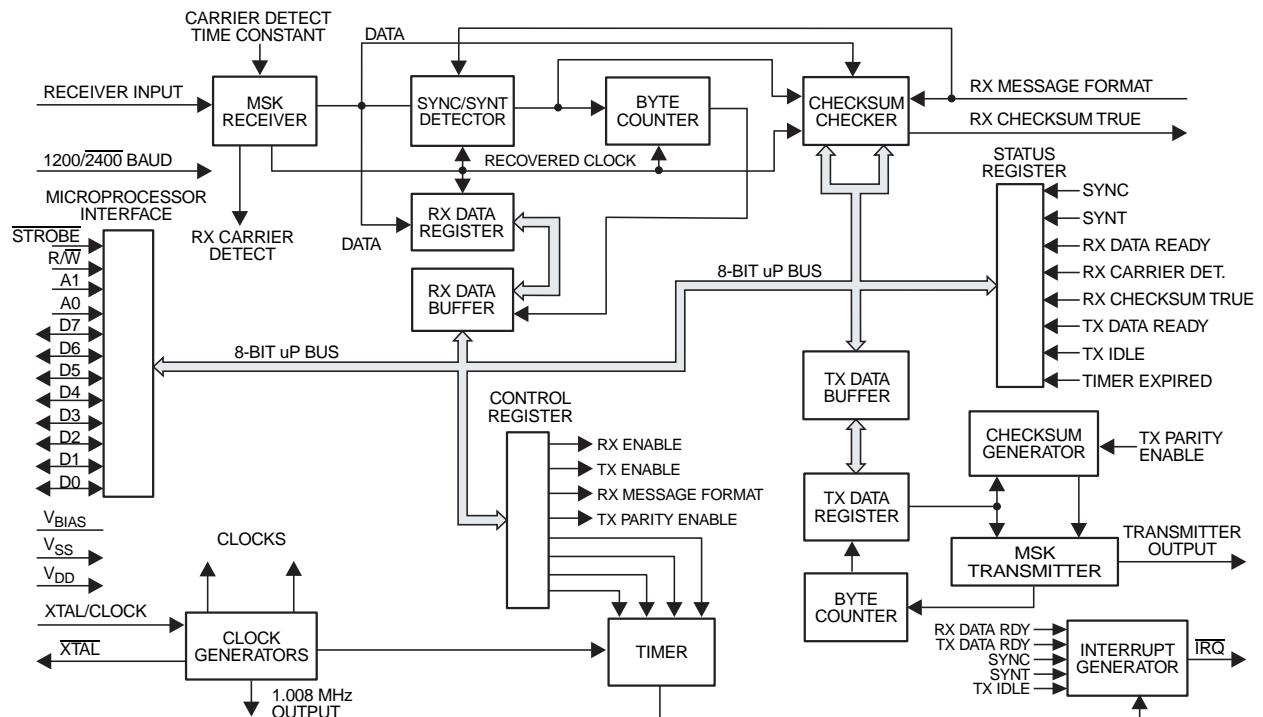

Figure 1: Block Diagram

## 2 Signal List

Pin No.		Signal		Description
J/P	LH	Name	Type	
1	1	V <sub>BIAS</sub>		The internal circuitry bias line, held at V <sub>DD</sub> /2 this pin must be decoupled to V <sub>SS</sub> by a capacitor, see Figure 2.
2	2	Transmit Output	Output	The 1200 baud, 1200Hz/1800Hz and 2400 baud, 1200Hz/2400Hz MSK Tx output. When not enabled by the Control Register (D0) its output impedance is set high.
3	4	Receiver Input	Input	The 1200/2400 baud received MSK signal input. The 1200Hz/1800Hz, 1200Hz/2400Hz audio to this pin must be ac coupled via a capacitor, see Figure 2.
5	5	V <sub>DD</sub>	Power	Positive Supply. A single +5V regulated supply is required. It is recommended that this power rail be decoupled to V <sub>SS</sub> by a capacitor, see Figure 2.
6	6	Carrier Detect Time Constant:		The on-chip Carrier Detect function requires external component(s) on this pin. See Figure 2 for recommended component(s).
7	7	Xtal/Clock		The input to the clock oscillator inverter. A 4.032 MHz Xtal or externally derived clock pulse input should be connected here, see Figure 2.
8	8	XTAL		The output of the 4.032 MHz clock oscillator.

Pin No.		Signal		Description
J/P	LH	Name	Type	
9	9	D0		Microprocessor Data Interface These 8 lines are used by the device to communicate with a micro-processor with the $R/\overline{W}$ , A0 and A1 inputs determining register selection.
10	10	D1		
11	11	D2		
12	12	D3		
13	13	D4		
14	14	D5		
15	15	D6		
16	16	D7		
17	17	A0		Register Selection: These inputs, with the $R/\overline{W}$ input, select the required register to the data bus as shown in Table 2
18	18	A1		
19	19	$\overline{\text{STROBE}}$		Performs the dual functions of selecting the device for Read or Write and strobing data in or out. It should be generated by gating the high order address bits with a Read/Write clock. The MX429A is selected when this pin is a logic '0'.
20	20	$R/\overline{W}$		Used in conjunction with A1 and A0 to determine which internal registers are connected to the data interface pins (D0 to D7) during Strobe.
21	21	$\overline{\text{IRQ}}$		Interrupt Request. This line will go to a logic '0' when an interrupt occurs. This output can be "wire OR'd" with other active low components (100k $\Omega$ pullup to $V_{DD}$ ). The conditions that cause the interrupts are indicated at the Status Register and are as follows: Timer Expired, Rx Data Ready, Tx Data Ready, Tx Idle, Rx SYNC Detect, Rx SYNT Detect
22	24	1200/ $\overline{2400}$ Baud Select		A logic '1' on this pin selects the 1200 baud option. Tone frequencies are: one cycle of 1200Hz represents a logic '1', one and a half cycles of 1800Hz represents a logic '0'. A logic '0' on this pin selects the 2400 baud option. Tone frequencies are: one half cycle of 1200Hz represents a logic '1', one cycle of 2400Hz represents a logic '0'. This pin has an internal 1M $\Omega$ pullup resistor.
23	22	$V_{SS}$	Power	Negative Supply (GND)
24	23	Clock/4		A 1.008 MHz ( $X1 \div 4$ ) clock is available at this output for external circuit use, note the source impedance and source current limits.
4	3			Leave this pin open-circuit

Table 1: Signal List

Register	R/W	A0	A1
Control	0	1	1
Status	1	1	1
Rx Data	1	0	1
Tx Data	0	0	1
Syndrom Low	1	0	0
Syndrom High	1	1	0

Table 2: Register Selection

### 3 External Components

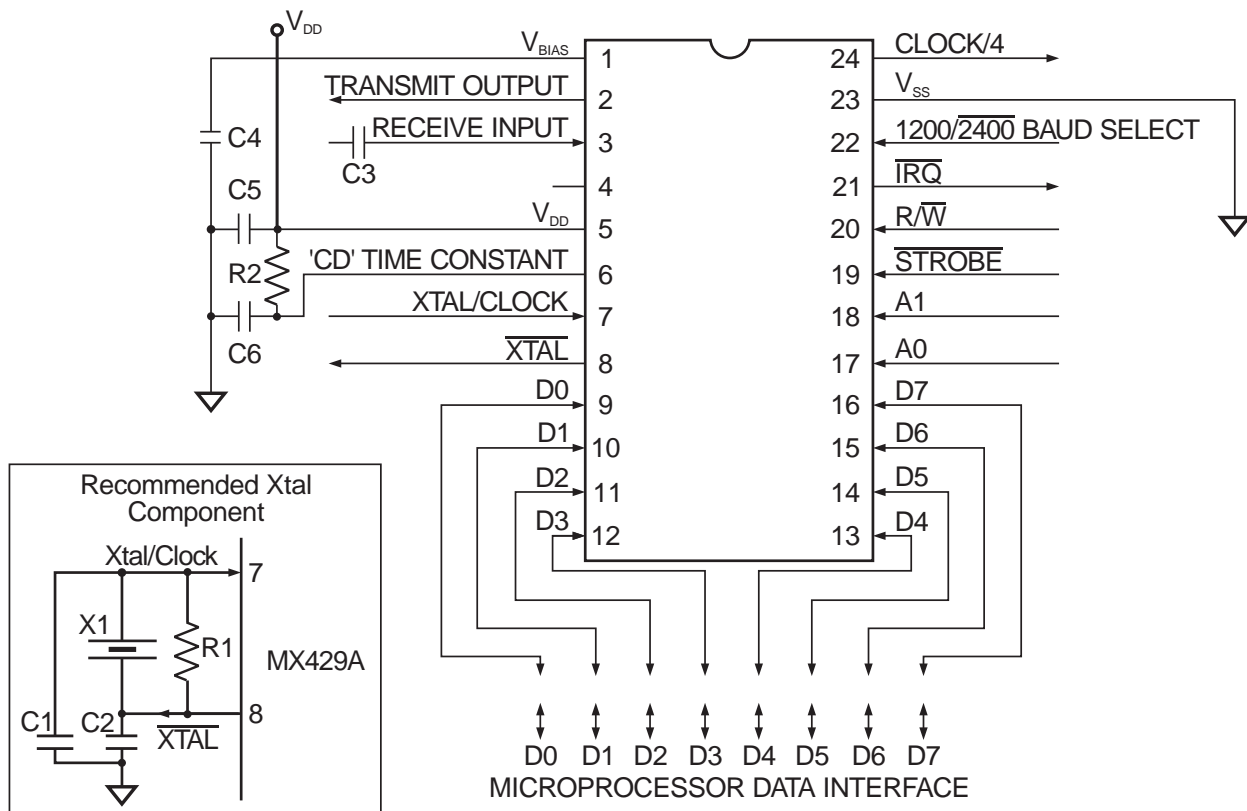

Figure 2: Recommended External Components

R1		1M $\Omega$	$\pm 10\%$	C4		1.0 $\mu\text{F}$	$\pm 20\%$
R2		1M $\Omega$	$\pm 10\%$	C5		1.0 $\mu\text{F}$	$\pm 20\%$
C1		33pF	$\pm 20\%$	C6		1.0 $\mu\text{F}$	$\pm 20\%$
C2		33pF	$\pm 20\%$				
C3		0.1 $\mu\text{F}$	$\pm 20\%$	X1	Note 1	4.032MHz	

Table 3: Recommended External Components

#### Notes:

1. For best results, a crystal oscillator design should drive the clock inverter input with signal levels of at least 40% of V<sub>DD</sub>, peak to peak. Tuning fork crystals generally cannot meet this requirement. To obtain crystal oscillator design assistance, consult your crystal manufacturer.

## 4 General Description

### 4.1 Modems in Mobile Data Signaling

#### 4.1.1 Digital Code Format

The MPT 1327 Signaling Standard for Trunked LMR Systems protocol is used by the MX429 for communication between a Trunking System Controller (TSC) and users' radio units. These data stream formats are summarized in Figure 3.

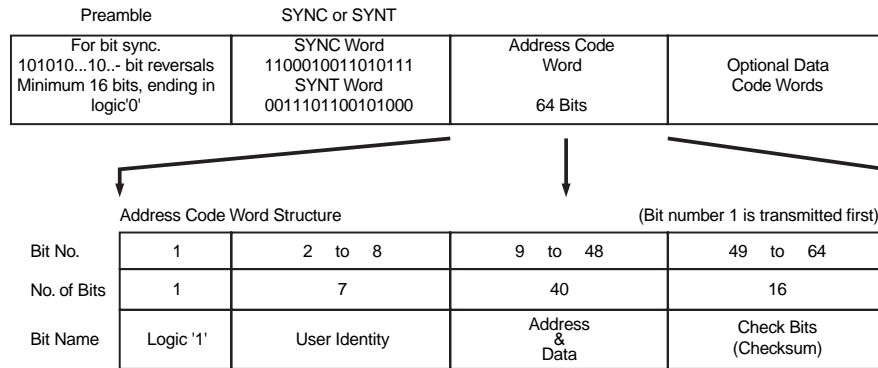

**Figure 3: Tx and Rx Data Stream**

#### 4.1.2 Operation

The MX429A can be used for Full-Duplex operation with the host microprocessor only having to operate on the data while the modem (MX429A) handles all other signaling routines and requirements.

In the Tx mode the MX429A will :

1. Internally generate and transmit a preamble – bit reversals, for system bit synchronization.
2. Accept from the host, and transmit, a 16-bit 'SYNC' or 'SYNT' word.
3. Accept from the host, and transmit, 6 bytes of data (Address Code Word):
  - A. Upon a software command, internally calculate and transmit a 2-byte checksum based on the previous 6 data bytes.
  - B. Upon a software command, disable internal checksum generation and allow continuous data transmission.
4. Transmit 1 'hang bit' and go idle when all loaded data traffic has been sent (followed by a "Tx Idle" interrupt).

In the Rx mode the MX429A will:

1. Detect and achieve bit synchronization within 16 bits.
2. Search for and detect the 16-bit 'SYNC'/'SYNT' word.
3. Output all received data after 'SYNC/SYNT,' in byte form.
4. Upon a software command (Rx Message Format), use the received checksum to calculate the presence (if any) of errors, and advise the host with an interrupt and a 16-bit Syndrome word.

Note: In Rx, a software command is used to determine whether a 'SYNC'/'SYNT' word is required after every 8 (6 data + 2 checksum ) received bytes, or "data" is received continually. Normally the 'SYNC' word is used on the Control data channel and the 'SYNT' word is used on the Traffic data channel.

#### 4.1.3 Non MPT Application – Full-Duplex

The functions described in this section, to allow the MX429A modem to operate as a general purpose device, are obtained using the commands and indications detailed in the "Register Instructions" pages.

**Tx:** When enabled the device transmits a "101010.....10" preamble until data for transmission is loaded by the host microprocessor. Transmits 6 bytes of the loaded data followed by a 2-byte checksum based on that data. As long as Tx data is loaded the transmitter will transmit, the 2-byte checksum being produced after every 6 bytes (8 byte packages). Automatic checksum generation can be inhibited by a software command to allow transmission of continuous data streams.

**Rx:** When enabled requires the 16-bit SYNC or SYNT word (see notes) before outputting data bytes. The modem receiver will then output continuous bytes of data, after every 6 bytes received a 2-byte checksum word will be output and can be ignored or used for error checking.

#### 4.1.4 Control Register (A1 = 1, A0 = 1, R/W = 0, Write Only)

The Control Register, when selected, directs the modem's operation as described in Table 4

Bit	Description	Function
Bit 0 D0	Tx Enable	<b>Set:</b> D0 enables the transmitter for operation. A '0 – 1' transition causes bit synchronization and the start of 1010.....10 preamble pattern transmission. At least one byte of preamble will be transmitted. If data is loaded into the Tx Data Buffer before one byte has been sent then that data will follow, otherwise whole bytes of preamble will continue until data is loaded. <b>Clear:</b> The Transmitter Output pin is set to a high impedance and no transmitter interrupts are produced.
Bit 1 D1	Tx Parity Enable	<b>Set:</b> D1 indicates to the transmitter that 2-byte checksums are to be generated by the modem. A '0 – 1' transition starts checksum generation on the next six bytes loaded from the Tx Data Buffer into the Tx Data Register. Checksum generation continues for every 6 bytes loaded until this bit is cleared. The transmitter will send the generated checksum (2 bytes) after the last of each 6 bytes have been sent. If an underrun (no more data loaded) condition occurs before 6 bytes have been loaded checksum generation will abort, the transmission will cease after one 'hang' bit has been sent and Bit 4 in the Status Register (Tx Idle) will be set. No checksum will be transmitted. <b>Clear:</b> No checksum generation is carried out and the host may supply the checksum bytes. The output is then "as written".
Bit 2 D2	Rx Enable	<b>Set:</b> D2 enables the receiver for operation. No data is produced (i.e. No Rx Data Ready interrupts) until a 'SYNC' or 'SYNT' word is found in the received bit stream. <b>Clear:</b> The receiver is disabled and all interrupts caused by the receiver are inhibited.
Bit 3 D3	Rx Message Format	<b>Set:</b> D3 is sampled after a checksum has been received and allows the host to control the way the receiver handles the following data bits. If 'set' the receiver will assume that the next 6 bytes are data and will start error checking accordingly. <b>Clear:</b> The receiver will stop data transfer to the host after the 2 checksum bytes until another 'SYNC' or 'SYNT' frame word is received.
Bit 4 D4	Timer LSB	Reference Table 5
Bit 5 D5	Timer	
Bit 6 D6	Timer	
Bit 7 D7	Timer MSB	If a new timer value is written to these inputs within 1 byte period of the last timer interrupt then the next timer period will be correct without first having to reset the timer, otherwise the timer must be reset to zero and then set to the new time.
Tx Enable		If using the internal Tx preamble generation facility, e.g. with the internal timer setting the preamble length, the device may occasionally produce a Tx Ready interrupt immediately after a Tx Enable command. User software should handle this occurrence by either: a. Detecting that the timer interrupt status bit is not set and that it is not appropriate to load Tx data at this time. b. Not using the timer. i.e. immediately after Tx Enable, reading the Status Register and loading a byte of preamble. This resets any interrupt. The length of preamble transmitted is now controlled by the number of bytes loaded.

Table 4: Control Register

D7	D6	D5	D4	Reset counter and disable timer interrupts				
0	0	0	0	Count and interrupt every				
0	0	0	1	"	"	"	8	bits
0	0	1	0	"	"	"	16	bits
0	0	1	1	"	"	"	24	bits
0	1	0	0	"	"	"	32	bits
0	1	0	1	"	"	"	40	bits
0	1	1	0	"	"	"	48	bits
0	1	1	1	"	"	"	56	bits
1	0	0	0	"	"	"	64	bits
1	0	0	1	"	"	"	72	bits
1	0	1	0	"	"	"	80	bits
1	0	1	1	"	"	"	88	bits
1	1	0	0	"	"	"	96	bits
1	1	0	1	"	"	"	104	bits
1	1	1	0	"	"	"	112	bits
1	1	1	1	"	"	"	120	bits

Table 5: Timer Control Bits

#### 4.1.5 Status Register (A1 = 1, A0 = 1, R/W = 1, Read Only)

When an interrupt is generated, the  $\overline{IRQ}$  Output goes low with the Status Register bits indicating the sources of the interrupt.

Bit	Description	Function
Bit 0 D0	Rx Data Ready	<b>D0:</b> when set, causes an interrupt indicating that received data is ready to be read from the Rx Data Buffer. This data must be read within 8 bit periods. <b>Set</b> when a byte of data is loaded into the Rx Data Buffer, if a frame (SYNC/SYNT) word has been received. <b>Bit and Interrupt Cleared:</b> (i). by a read of the Status Register followed by a read of the Rx Data Buffer (ii). by Rx Enable going Low.
Bit 1 D1	Rx Checksum True	<b>D1:</b> when set, indicates that the error checking on the previous 6 bytes agreed with the received checksum. This function, which is valid when the Rx Data Ready bit (D0) is set for the second byte of the received checksum, does not cause an interrupt. <b>Set:</b> by a correct comparison between the received and generated checksums. <b>Cleared:</b> (i). by a read of the Status Register followed by a read of the Rx Data Buffer (ii). by Rx Enable going Low.
Bit 2 D2	Rx Carrier Detect	<b>D2:</b> is a "Real Time" indication from the modem receiver's carrier detect circuit and does not cause an interrupt. When MSK tones are present at the receiver input this bit goes High, for no MSK input this bit goes Low. When the Rx Enable bit (D2- Control Register) is Low Rx Carrier Detect will go Low.
Bit 3 D3	Tx Data Ready	<b>D3:</b> when set, causes an interrupt to indicate that a byte of data should be written to the Tx Data Buffer within 8 bit periods. <b>Set:</b> (i). when the contents of the Tx Data Buffer are transferred to the Tx Data Register (ii). when the Tx Enable is set (No interrupt is generated in this case). <b>Bit Cleared:</b> (i). by a read of the Status Register followed by a write to the Tx Data Buffer (ii). by Tx Enable going Low. <b>Interrupt Cleared:</b>



Bit	Description	Function
		(i). by a read of the Status Register (ii). by Tx Enable going Low.
Bit 4 D4	Tx Idle	<b>D4:</b> causes an interrupt when set, to indicate that all loaded data and one 'hang' bit have been transmitted. <b>Set:</b> one bit period after the last byte is transmitted. This last byte could be either "checksum" or "loaded data" depending upon the Tx Parity Enable state (Control Register D1). <b>Bit Cleared:</b> (i). by a write to the Tx Data Buffer (ii). by Tx Enable going Low. <b>Interrupt Cleared:</b> (i). by a read of the Status Register (ii). by Tx Enable going Low.
Bit 5 D5	Timer Interrupt	<b>D4:</b> causes an interrupt when set, to indicate that all loaded data and one 'hang' bit have been transmitted. <b>Set:</b> one bit period after the last byte is transmitted. This last byte could be either "checksum" or "loaded data" depending upon the Tx Parity Enable state (Control Register D1). <b>Bit Cleared:</b> (i). by a write to the Tx Data Buffer (ii). by Tx Enable going Low <b>Interrupt Cleared:</b> (i). by a read of the Status Register (ii). by Tx Enable going Low.
Bit 6 D6	Rx SYNC Detect *	<b>D6:</b> when set, causes an interrupt to indicate that a 16-bit 'SYNC' word (1100010011010111) has been detected in the received bit stream. <b>Set:</b> on receipt of the 16th bit of a 'SYNC' word. <b>Bit and Interrupt Cleared:</b> (i). by a read of the Status Register (ii). by Rx Enable going Low.
Bit 7 D7	Rx SYNT Detect *	<b>D7:</b> when set, causes an interrupt to indicate that a 16-bit 'SYNT' word (0011101100101000 ) has been detected in the received bit stream. <b>Set:</b> on receipt of the 16th bit of a 'SYNT' word. <b>Bit and Interrupt Cleared:</b> (i). by a read of the Status Register (ii). by Rx Enable going Low.

\* SYNC and SYNT Detection is disabled while the checksum checker is running.

**Table 6: Status Register**

#### 4.1.6 Rx Data Buffer (A1 = 1, A0 = 0, R/W = 1, Read Only)

These 8 bits are the last byte of data received with bit 7 being received first. Note the relative positions of the MSB and LSB presented in this bit stream, the position may be different to the convention used in other  $\mu$ Processor peripherals.

D0 LSB	D1	D2	D3	D4	D5	D6	D7 MSB
-----------	----	----	----	----	----	----	-----------

#### 4.1.7 Tx Data Buffer (A1 = 1, A0 = 0, R/W = 0, Write Only)

These 8 bits loaded to the Tx Data Buffer are the next byte of data that will be transmitted, with bit 7 being transmitted first. Note the relative positions of the MSB and LSB presented in this bit stream, the position may be different to the convention used in other  $\mu$ Processor peripherals. If the Tx Parity Enable bit (Control Register D1 ) is set, a 2-byte checksum will be inserted and transmitted by the modem after every 6 transmitted "message" bytes.

D0 LSB	D1	D2	D3	D4	D5	D6	D7 MSB
-----------	----	----	----	----	----	----	-----------

## 4.2 Syndrome Word

This 16-bit word (both Low and High bytes) may be used to correct errors. Bits S1 to S15 are the 15 bits remaining in the polynomial divider of the checksum checker at the end of 6 bytes of “received message.” For a correct message all 15 bits (S1 to S15) will be zero. The 2 Syndrome bytes are valid when the Rx Data Ready bit (Status Register D0) is set for the second byte of the received checksum and should be read, if required, before 8 byte periods.

### 4.2.1 Syndrome Low Byte (A1 = 0, A0 = 0, R/W = 1, Read Only)

D0	D1	D2	D3	D4	D5	D6	D7
S1	S2	S3	S4	S5	S6	S7	S8

### 4.2.2 Syndrome High Byte (A1 = 0, A0 = 1, R/W = 1, Read Only)

D0	D1	D2	D3	D4	D5	D6	D7
S9	S10	S11	S12	S13	S14	S15	Parity Error

**D7:** This is a “Parity Error Bit”. Indicating an error between the received parity bit and the parity bit internally generated from the incoming message. Therefore a correctly received message all 16 bits of the Syndrome Word

(S1 to S15 and Parity Error) will be zero.

## 4.3 Carrier Detect Time Constant

The value of the Carrier Detect capacitor, C5, determines the carrier detect time constant. A long time constant (larger value C5) results in improved noise immunity but increased response time. C5 may be varied to optimize noise immunity/response time.

1. With R2 = 1M $\Omega$  and C5 = 1 $\mu$ F as external components for the carrier detect function at 1200 baud only.
2. By using C5 = 0.1 $\mu$ F and removing R2 completely the MX429A will operate at both 1200 and 2400 baud rates.

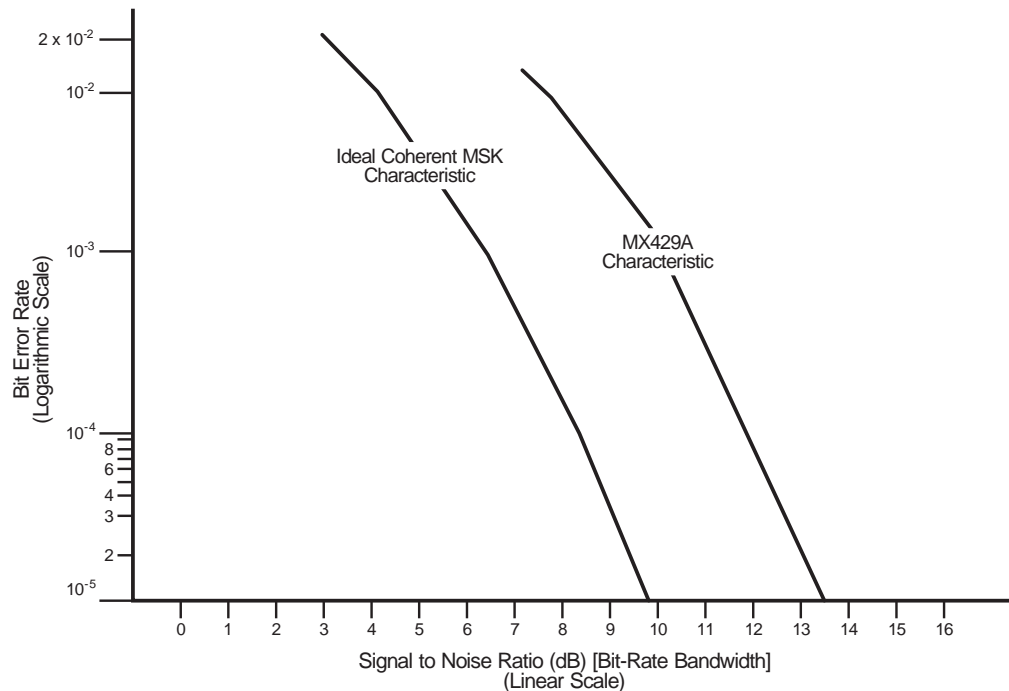

Figure 4: Bit Error Rate vs. Signal to Noise Ratio

## 5 Application

### 5.1 Checksum Generation and Checking

Generation – The checksum generator takes the 48 bits from the 6 bytes loaded into the Tx Data Buffer and divides them modulo–2, by the generating polynomial;–

$$X^{15} + X^{14} + X^{13} + X^{11} + X^4 + X^2 + 1$$

It then takes the 15-bit remainder from the polynomial divider, inverts the last bit and appends an EVEN parity bit generated from the initial 48 bits and the 15 bit remainder (with the last bit inverted). This 16–bit word is used as the "Checksum."

Checking – The checksum checker does two things:

It takes the first 63 bits of a received message, inverts bit 63, and divides them modulo–2, by the generating polynomial;–

$$X^{15} + X^{14} + X^{13} + X^{11} + X^4 + X^2 + 1$$

The 15 bits remaining in the polynomial divider are checked for all zero. Secondly, it generates an EVEN parity bit from the first 63 bits of a received message and compares this bit with the received parity bit (bit 64). If the 15 bits in the polynomial divider are all zero, and the two parity bits are equal, then the Rx Checksum True bit (SR D1) bit is set.

### 5.2 Receive Operation

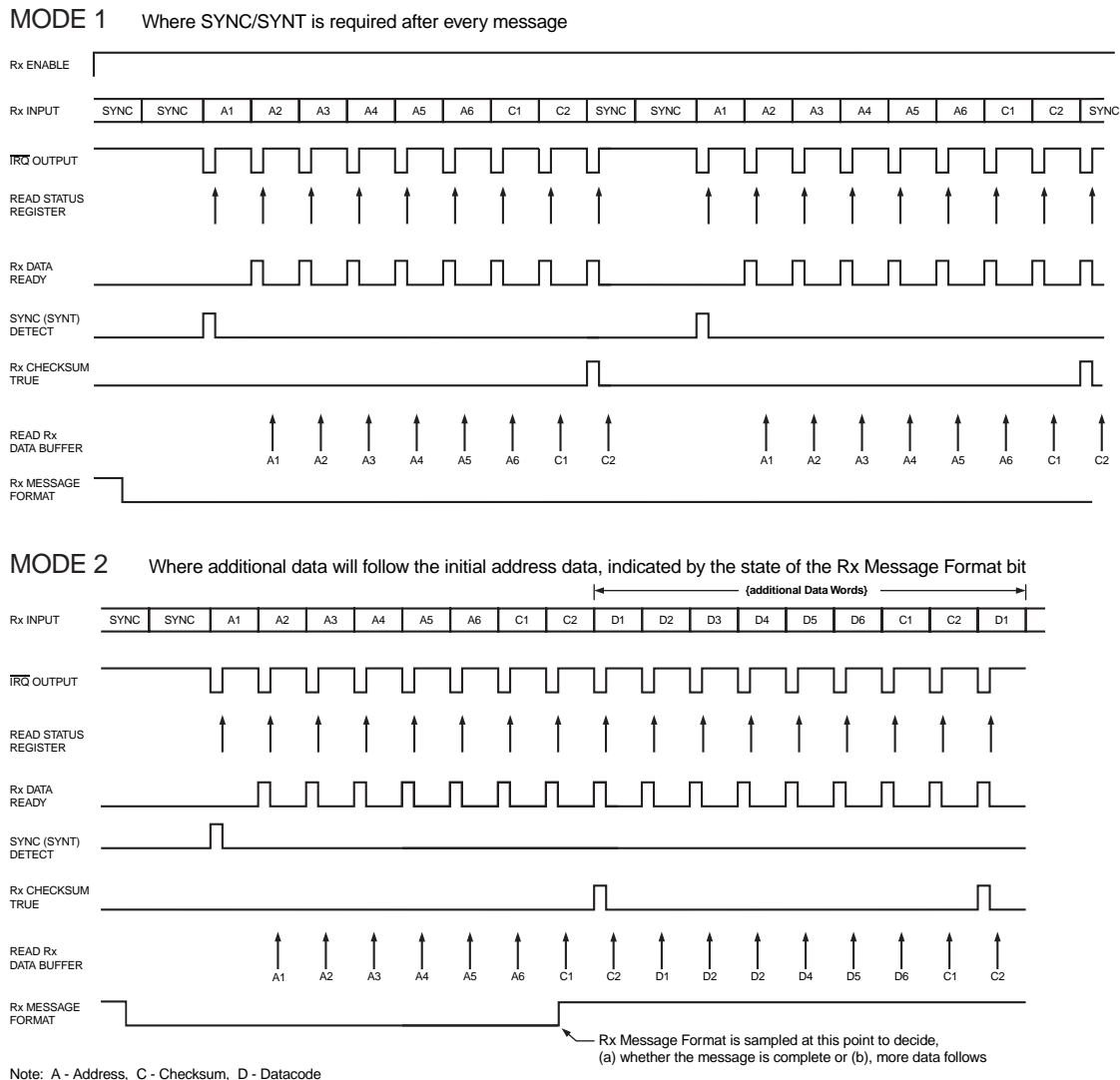

**Figure 5: Receive Operation**

### 5.3 Transmit Operation

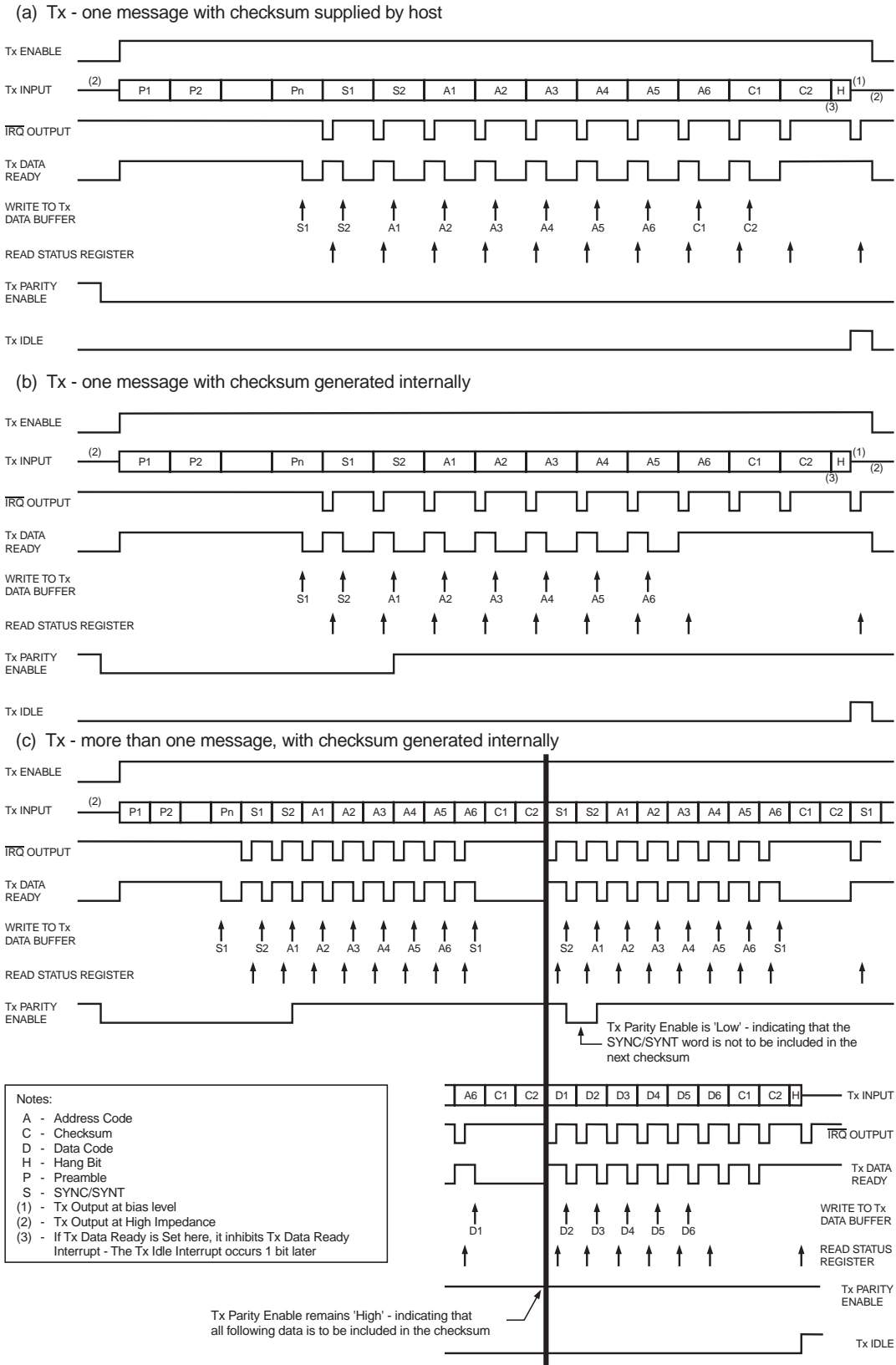

Figure 6: Transmit Operation

## 5.4 Basic Power Up Software

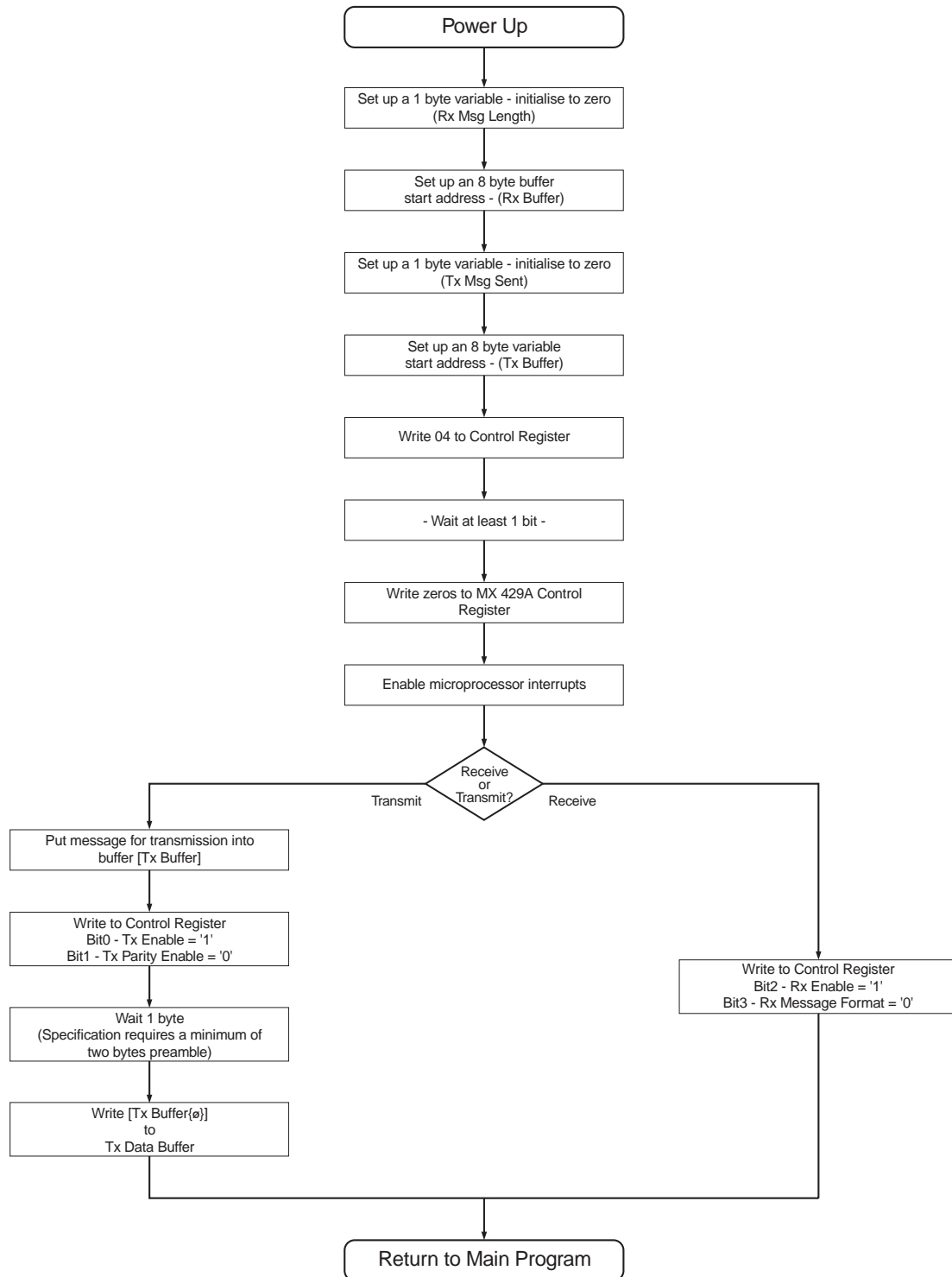

Figure 7: Basic Power-Up Software

### 5.5 Basic Software Interrupt Flow

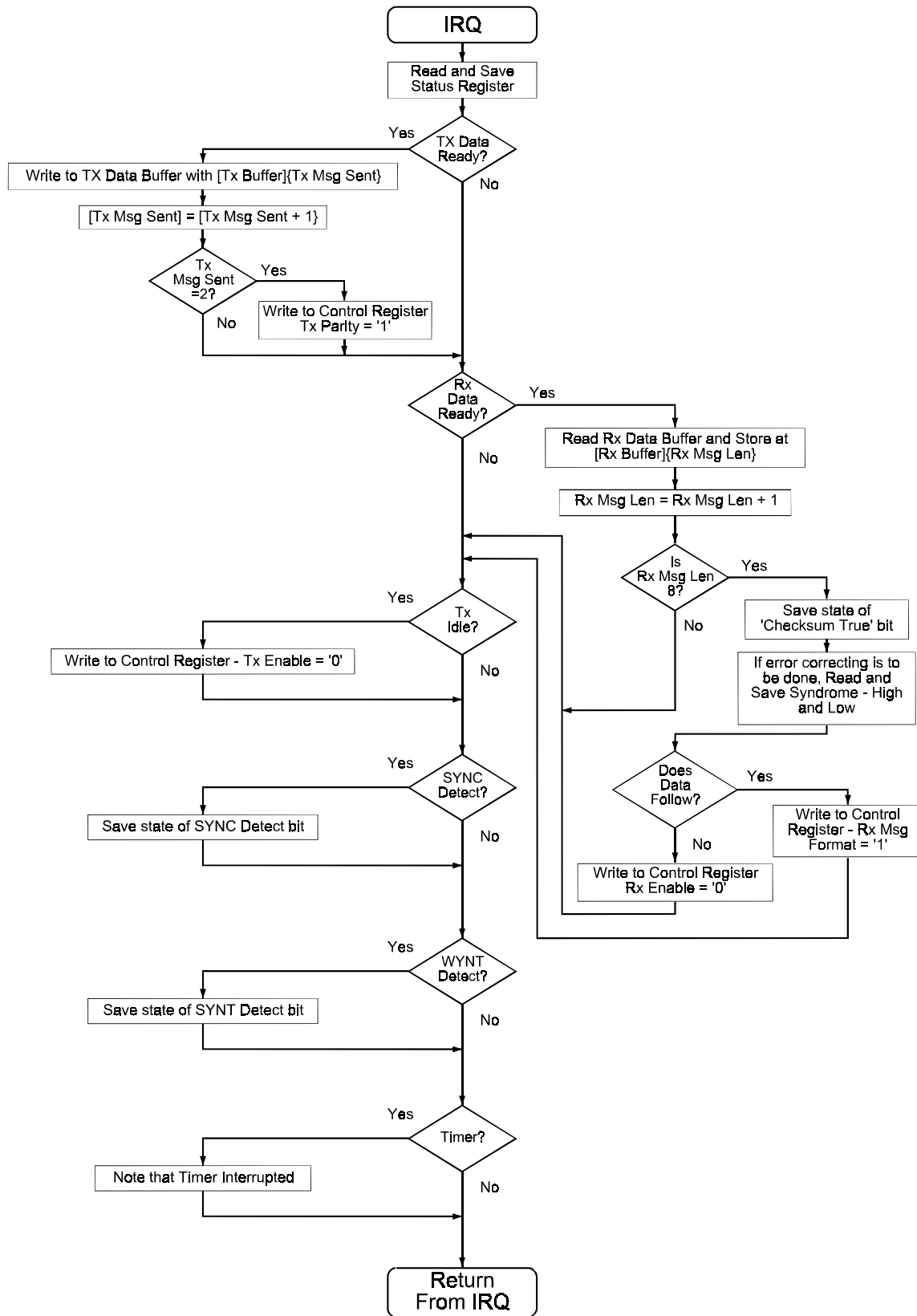

Figure 8: Basic Software Interrupt Flow

## 5.6 Bus Interface Timing

It is very important that circuit designs conform to the bus interface timing specification as described in Section 6.1.4. Failure to do so can result in intermittent operation that is difficult to troubleshoot.

For example, if the bus timing is incorrect, the required two step READ Rx data transaction (1: Read Status Register, 2: Read Rx Data Buffer) may fail on step 2. As a result, the MX429A IRQ will not be reset and subsequently expected IRQ's will not occur. This symptom might be incorrectly interpreted as an MX429A functional failure but is, in fact, caused by the circuit design's bus interface timing violation.

Other examples can occur on WRITE transactions that fail to properly clear the IRQ and so prevent subsequently expected IRQ's from occurring.

Circuit designs should be careful to strictly conform to the  $t_{DHW}$  specification, the Data Hold Time (Write), as assumed requirements may be incorrect.

### 5.6.1 Bus interface design migration from MX429 to MX429A

The MX429A bus interface timing requirements precisely match those of its predecessor, the MX429. As a result, properly designed and operated MX429 bus interface circuits are compatible with the MX429A device.

It should be noted that the MX429 and MX429A device may behave ***differently in those designs, which violate the bus timing specification.*** However, this is caused by the timing violation rather than an incompatibility between the two devices.

## 6 Performance Specification

### 6.1 Electrical Performance

#### 6.1.1 Absolute Maximum Ratings

Exceeding these maximum ratings can result in damage to the device.

General	Notes	Min.	Typ.	Max.	Units
Supply ( $V_{DD}-V_{SS}$ )		-0.3		7.0	V
Voltage on any pin to $V_{SS}$		-0.3		$V_{DD} + 0.3$	V
Current					
$V_{DD}$		-30		30	mA
$V_{SS}$		-30		30	mA
Any other pin		-20		20	mA
<b>J / P / LH Package</b>					
Total allowable Power Dissipation at $T_{AMB} = 25^{\circ}C$				800	mW
Derating above $25^{\circ}C$			10		mW/ $^{\circ}C$ above $^{\circ}C$
Operating Temperature		-40		85	$^{\circ}C$
Storage Temperature		-55		125	$^{\circ}C$

#### 6.1.2 Operating Limits

Correct operation of the device outside these limits is not implied.

	Notes	Min.	Typ.	Max.	Units
Supply ( $V_{DD}-V_{SS}$ )		4.5	5.0	5.5	V
Operating Temperature		-40		85	$^{\circ}C$
Xtal Frequency			4.032		MHz

### 6.1.3 Operating Characteristics

For the following conditions unless otherwise specified:

$V_{DD} = 5.0V$ ,  $T_{AMB} = 25^{\circ}C$ , Xtal/Clock  $f_0 = 4.032MHz$

Bit Rate Bandwidth = 1200Hz, Audio Level 0dB ref: = 300mV<sub>RMS</sub>

Static Values	Notes	Min.	Typ.	Max.	Units
<b>Static Values</b>					
Supply Current Ranges					
Rx and Tx Enabled				7.0	mA
Rx Enabled, Tx Disabled			4.0	6.0	mA
Rx Disabled, Tx Enabled				7.0	mA
Rx and Tx Disabled			1.5	2.5	mA
<b>Dynamic Values</b>					
Modem Internal Delay			1.5		ms
<b>Interface Levels</b>					
Output Logic '1' Source Current	2			120	$\mu A$
Output Logic '0' Sink Current	3			360	$\mu A$
Three State Output Leakage Current				4.0	$\mu A$
<b>D0 – D7 Data In/Out</b>					
Logic '1' Level		3.5			V
Logic '0' Level				1.5	V
<b>A1, A0, R/W, STROBE, IRQ</b>					
Logic '1' Level	4	4.0			V
Logic '0' Level				1.0	V
<b>Analog Impedance's</b>					
Rx Input		100			k $\Omega$
Tx Output (Enabled)			10		k $\Omega$
Tx Output (Disabled)			5.0		M $\Omega$
<b>On-Chip Xtal Oscillator</b>					
R <sub>IN</sub>		10.0			M $\Omega$
R <sub>OUT</sub>	5		30.0		k $\Omega$
Oscillator Gain			25.0		dB
Xtal frequency			4.032		MHz
<b>Receiver</b>					
Signal Input Levels	6	-9.0	-2.0	10.5	dB
Bit Error Rate	7				
@ 12dB Signal/Noise Ratio			7.0		10 <sup>-4</sup>
@ 20dB Signal/Noise Ratio			1.0		10 <sup>-8</sup>
Synchronization @ 12dB Signal/Noise Ratio	8				
Probability of Bit 16 being correct			99.5		%
Carrier Detect Response Time	8		13.0		ms



Static Values	Notes	Min.	Typ.	Max.	Units
<b>Transmitter</b>					
Output Level			8.25		dB
Output Level Variation	10	-1.0		1.0	dB
Output Distortion			3.0	5.0	%
3rd Harmonic Distortion			2.0	3.0	%
Logic '1' Frequency	1200 baud	9	1200		Hz
	2400 baud	9	1200		Hz
Logic '0' Frequency	1200 baud	9	1800		Hz
	2400 baud	9	2400		Hz
Isochronous Distortion					
	1200Hz – 1800Hz/1200Hz - 2400Hz		25	40	μs
	1800Hz – 1200Hz/2400Hz - 1200Hz		20	40	μs

### Operating Characteristics Notes:

1. With each data line loaded as, C = 50pf and R = 10kΩ.
2.  $V_{OUT} = 4.6V$ .
3.  $V_{OUT} = 0.4V$
4. Sink/Source currents  $\leq 0.1mA$ .
5. Both Xtal and Xtal  $\div 4$  Outputs.
6. With 50dB Signal/Noise Ratio.
7. See Figure 4, Bit Error Rate.
8. This Response Time is measured using a 10101010101.... 01 pattern input signal at a level of  $230mV_{RMS}$  (-2.3dB) with no noise.
9. Dependent upon Xtal tolerance.
10. The amplitude difference between the Transmit Output signals (tones) representing a logic '0' a logic '1'.

### 6.1.4 Timing

Timing see Figure 9		Min.	Typ.	Max.	Units
( $t_{ACS}$ )	Access Time			135	ns
( $t_{AH}$ )	Address Hold Time	0			ns
( $t_{AS}$ )	Address Set-up Time	0			ns
( $t_{DHW}$ )	Data Hold Time (Write)	85			ns
( $t_{DS}$ )	Data Set-up Time (Write)	0			ns
( $t_{OHR}$ )	Output Hold Time (Read)	15		105	ns
( $t_{ST}$ )	Strobe Time	140			ns

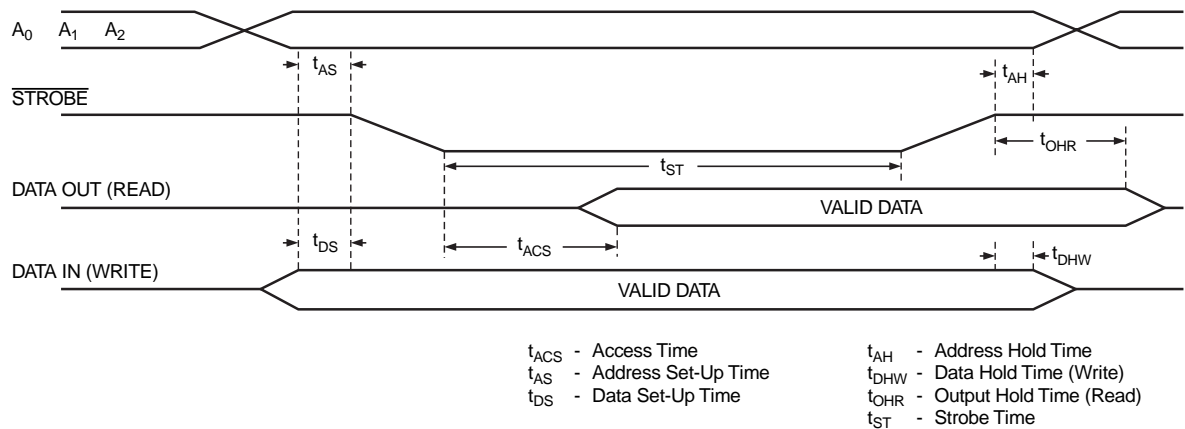

Figure 9: Timing Diagram

### 6.2 Packaging

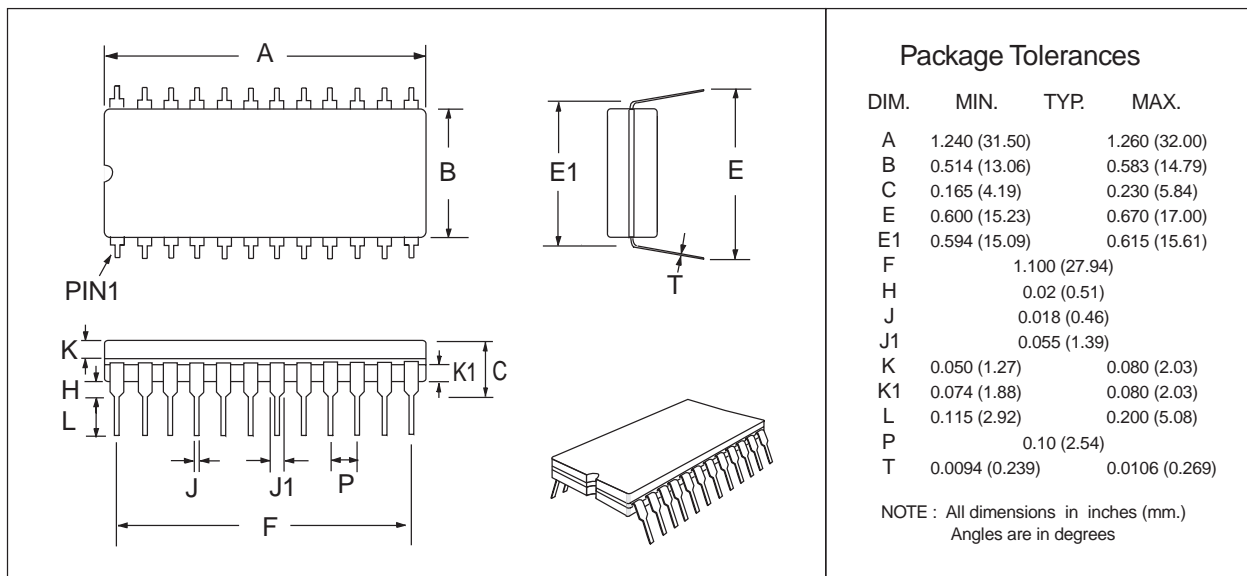

Figure 10: 24-pin CDIP Mechanical Outline: *order as part no. MX429AJ*

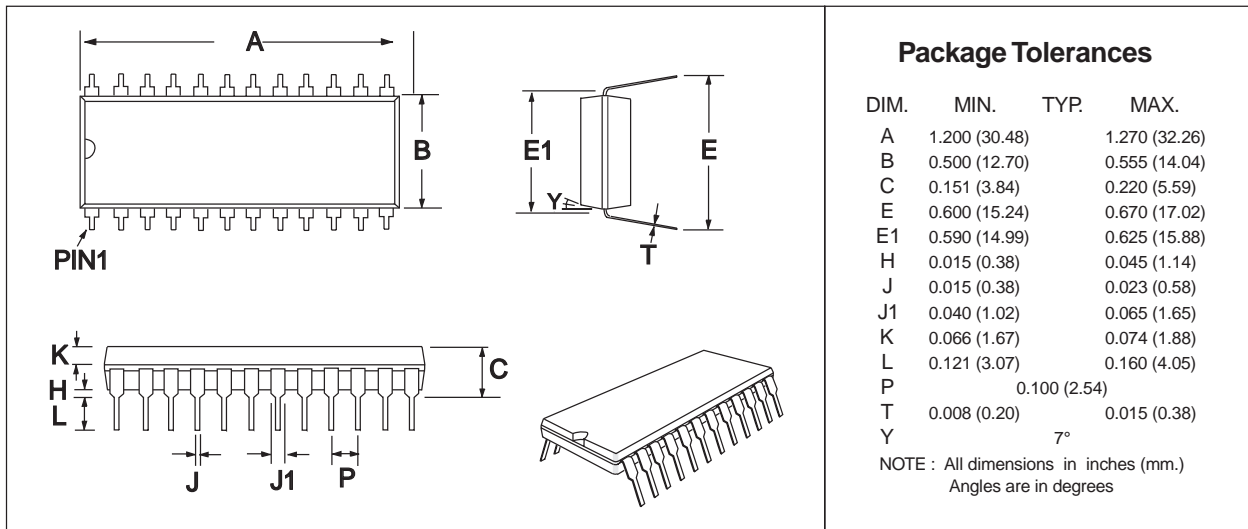

Figure 11: 24-pin PDIP Mechanical Outline: *order as part no. MX429AP*

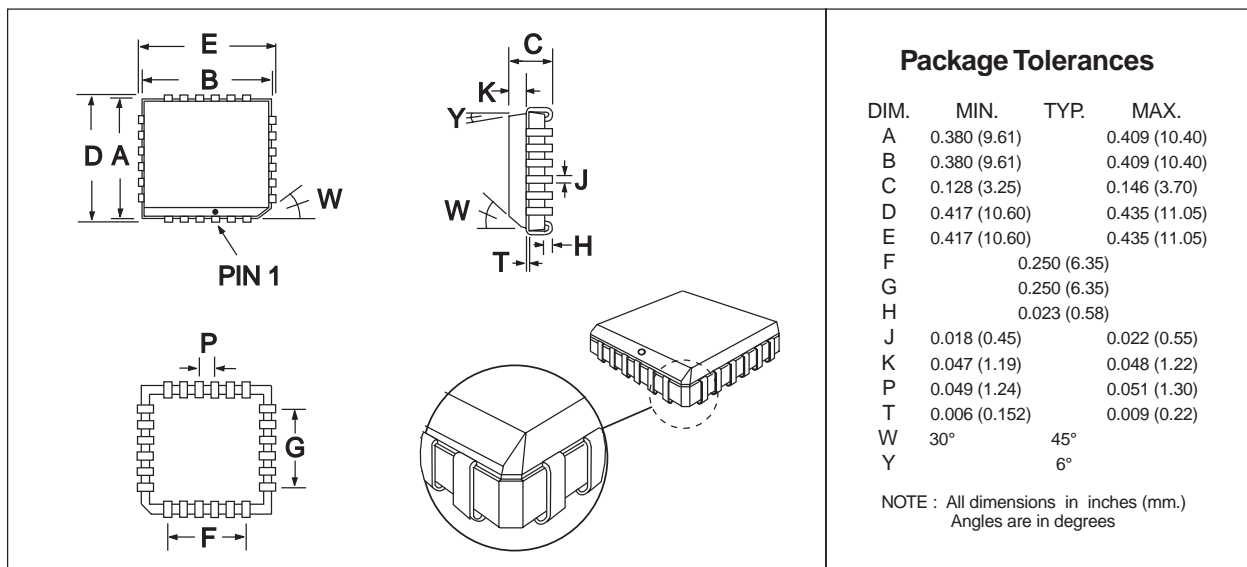

Figure 12: 24-pin PLCC Mechanical Outline: *order as part no. MX429ALH*