

# HDMI<sup>®</sup> Port

## HDMI 1.3 - ESD & Overcurrent Protection

### Solution Products

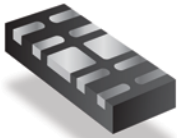

CDDFN10-0524P

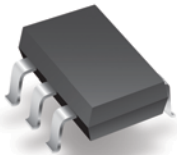

CDSOT236-0504LC



MF-FSMF020X-2

### Design Kit



PN-DESIGNKIT 11

### Objective

HDMI 1.3 interfaces are 3.3 V differential digital signals with single-link bandwidths up to 340 MHz (10.2 Gbit/s). As usage of HDMI ports increases, HDMI ports face a growing threat of ESD damage.

### Solution

2 TVS Diode Arrays: CDDFN10-0524P  
1 TVS Diode Array: CDSOT236-0504LC  
1 Multifuse<sup>®</sup> PPTC: MF-FSMF020X-2

### Compliance

IEC 61000-4-2 Level 4 (8 kV / 15 kV)

### Alternate Recommendations

Other PortNote<sup>®</sup> Solutions:

- HDMI: HDMI 1.4 - ESD & Overcurrent Protection

### Benefit

This solution provides IEC 61000 Level 4 ESD protection without impairing the HDMI signal.

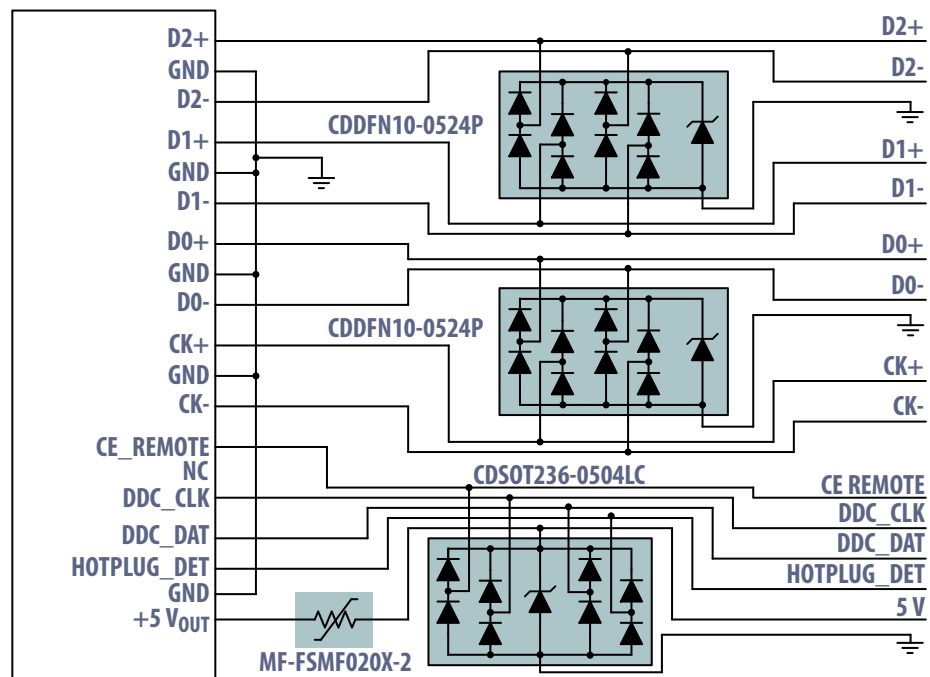

The schematic above illustrates the application protection and does not constitute the complete circuit design. Customers should verify actual device performance in their specific applications.