

Features

- 95% Efficient possible DC/DC Converter
- Combine Step-Up and Step-Down for 90% Efficient Boost-Buck
- Built-in LED Driver and Open LED Overvoltage Protection
- Transformerless Inverting Controller for CCD Bias
- 2 Channel Built-in MOSFET Current- Mode PWM and 4 Channel Extra PWM Controllers (CH-3 Synchronous Output)
- Up to 1MHz Operating Frequency
- Shutdown Current <1uA
- Built-in Soft-Start Function
- Built-in Short-Circuit Protection Function
- QFN48 Package

Applications

- DSC Power Supply

General Description

The AT1396A/B/C/D provide a complete power supply solution for digital cameras. They improve performance, component count, and size compared to other multi-channel controllers in 2-cell AA, 1-cell Li-Ion, and dual-battery designs. On-chip MOSFETs provide up to 92~95% efficiency for critical power supplies, while additional channels operate with external FETs for optimum design flexibility. All channels DC/DC operate at one fixed frequency settable from 100KHz to 1MHz to optimize size, cost, and efficiency.

Pin Assignment

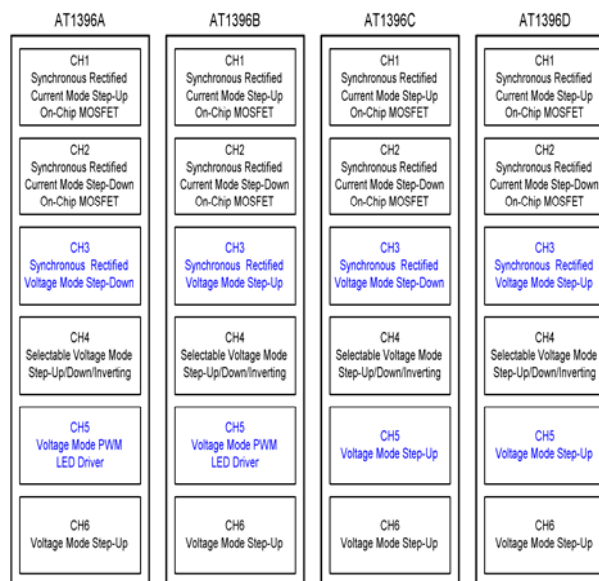
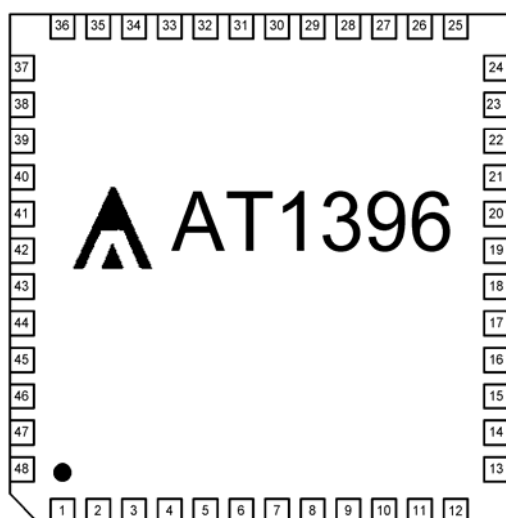

Ordering Information

Part Number	Package	Marking
AT1396AN	QFN48,Green	AT1396AN
AT1396BN	QFN48,Green	AT1396BN
AT1396CN	QFN48,Green	AT1396CN
AT1396DN	QFN48,Green	AT1396DN

Aimtron reserves the right without notice to change this circuitry and specifications.

Block Diagram

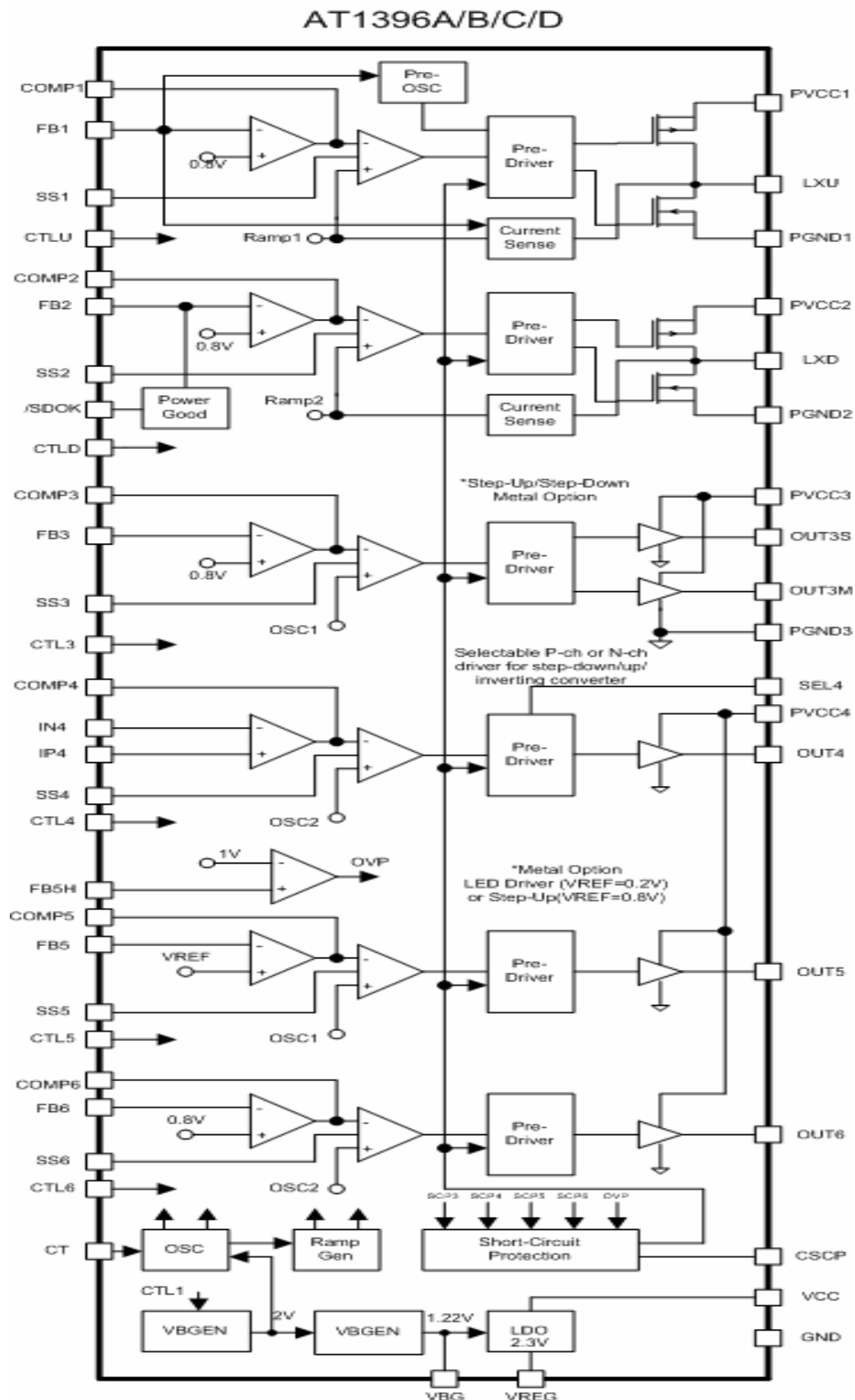

Pin Description

Pin No.	Pin name	I/O	Description
1	SS1	I	CH1 Soft-Start Input
2	CTL5	I	CH5 Enable Input
3	CTL6	I	CH6 Enable Input
4	LXU	O	Step-Up Converter Switching Node
5	CTLU	I	CH1 Enable and Chip Enable Input
6	PGND1	P	Power Ground
7	PGND2	P	Power Ground
8	CTLD	I	CH2 Enable Input
9	LXD	O	Step-Down Converter Switching Node
10	CTL3	I	CH3 Enable Input
11	CTL4	I	CH4 Enable Input
12	SS2	I	CH2 Soft-Start Input
13	/SDOK	O	Open-Drain, Active Low, Power Good for Step-Down
14	CSCP	I	Short Circuit Protection Input
15	PVCC2	P	Step-Down Converter Input
16	COMP2	O	Step-Down Converter Compensation Node
17	FBD	I	Step-Down Converter Feedback Input
18	SS3	I	CH3 Soft-Start Input
19	COMP3	O	CH3 Compensation Node
20	FB3	I	CH3 Feedback Input
21	SS4	I	CH4 Soft-Start Input
22	COMP4	O	CH4 Compensation Node
23	IN4	I	CH4 Negative Feedback Input
24	IP4	I	CH4 Positive Feedback Input
25	PVCC3	P	CH3 Power
26	OUT3M	O	CH3 Master Output Driver
27	OUT3S	O	CH3 Slave Output Driver
28	PGND3	P	Power Ground
29	OUT4	O	CH4 Output Driver
30	OUT5	O	CH5 Output Driver
31	OUT6	O	CH6 Output Driver
32	PVCC4	P	CH4 Power
33	GND	P	Power Ground
34	FB5H	I	CH5 Controller Voltage Feedback Input
35	FB5	I	CH5 Controller Voltage Feedback/Current Feedback
36	COMP5	O	CH5 Compensation Node
37	VBG	O	Reference Bypass
38	SS5	I	CH5 Soft-Start Input
39	FB6	I	CH6 Feedback input
40	COMP6	O	CH6 Compensation Node
41	CT	O	Oscillator Control
42	VREG	P	Reference Output
43	FBU	I	Step-Up Converter Input
44	COMP1	O	Step-Up Controller Compensation Node
45	VCC	P	IC power Input
46	PVCC1	P	Power Output of the Step-Up Converter
47	SS6	I	CH6 Soft-Start Input
48	SEL4	I	Configures the CH4 as a Step-Up or Step-Down

Absolute Maximum Ratings

Item	Symbol	Ratings	Units
Storage temperature	T _{STG}	-55 ~ +150	°C
Operating temperature	T _{OPR}	-30 ~ +85	°C
PVCC1,PVCC2,PVCC3,PVCC4 4 input voltage		-0.3 ~ +5.5	V
LXU,LXD, OUT3M,OUT3S input voltage	V _{LX/OUT}	-0.3V ~ +5.5	V
Other input Pin		-0.3V ~ +5.5	V
LXU Current		3.6	A
LXD Current		2.25	A
OUT3M,OUT3S Current		200	mA
Power consumption	Pd	1000	mW
ESD Classification		2	KV

Electrical Characteristics

(PVCC1=PVCC2=PVCC3=PVCC4=VCC=3.6V, Ta=+25°C)

Parameter	Symbol	Condition	Values			Unit
			Min.	Typ.	Max.	
GENERAL						
Input Voltage Range	VCC	Channel 1 DC/DC	1.2	-	5.5	V
CH1,CH2 Switch- Off Input Current	I _{VCC}	No Switching, FBU=FBD=0.9V CTLU=CTLD=3.6V,other disable	-	1	1.1	mA
CH1,CH2, CH3(or 4,5,6) Switch- Off Input Current	I _{VCC}	No Switching, FBU=FBD=FB3=0.9V CTLU=CTLD=CTL3=3.6V other disable	-	1.2	1.3	mA
Shutdown Current	I _{VCC}	All CTL disable	-	1	10	μA
REFERENCE						
Reference Output Voltage	V _{REG}	I _{REG} =1mA	2.275	2.30	2.325	V
Reference Load Regulation	ΔV _{REG1}	1mA < I _{REG} < 10mA	-	5	10	mV
Reference Line Regulation	ΔV _{REG2}	2.5 < VCC < 5.5V	-	-	5	mV
OSC						
Frequency	f _{OSC}	CT=82pF	-	500	-	KHz
Frequency variation with Temperature	Δf _{OSC1}	T _a =-20°C ~+85°C	-	1	10	%



圓創科技股份有限公司

AT1396A/B/C/D

Preliminary Product Information 6-Channel DC-DC Converter for DSC

Frequency variation with Input Voltage	Δf_{OSC2}	$V_{CC} = 2.5V \sim 5.5V$	-	1	5	%
CHANNEL 1(STEP-UP)						
Pre-OSC to OSC Trip Level	V_{CC1}	VCC rising edge	-	2.45	-	V
Pre-OSC to OSC Hysteresis	ΔV_{CC1}		-	100	-	mV
Under Voltage Lockout	VCC		-	2.45	-	V
Input Voltage Range	PVCC1	Channel 1 DC/DC	1.2	-	6.0	V
Normal Operating Soft-Start Charge Current	I_{SS1}	$V_{CC} = 2.5V \sim 5.5V$	0.8	1	1.5	μA
FBU Regulation Voltage	V_{FBU}	$T_a = -20^\circ C \sim +85^\circ C$	0.784	0.8	0.816	V
FBU input Current	I_{FBU}	FBU=0.8V	-	-	100	nA
Current-Sense Amplifier Transresistance	R_{CS}		-	0.285	-	V/A
Transconductance	G_{MEA}		-	140	-	μs
Maximum Duty Cycle	D_{MAX}	FBU=0.7V	85	90	95	%
PVCC1 Leakage Current	I_{L1}	$V_{LXU} = 0V, PVCC1 = 5.5V$	-	5	12	μA
LX Leakage Current	I_{LX1}	$V_{LXU} = 5.5V$	-	1	5	μA
Switch On-Resistance	R_N	N-Channel	-	95	150	m Ω
	R_P	P-Channel	-	150	250	m Ω
N-Channel Current Limit	I_{Limit1}		1.8	2.1	2.4	A
P-Channel Turn-off Current	I_{REV1}		-	20	-	mA
Startup Current Limit	$I_{Limit-s}$	PVCC1=1.5V	-	450	-	mA
Startup Frequency	f_{START}	PVCC1=1.5V	-	200	-	KHz
CHANNEL 2(STEP-DOWN)						
Input Voltage Range	PVCC2	Channel 2 DC/DC	1.2	-	6.0	V
Normal Operating Soft-Start Charge Current	I_{SS2}	$V_{CC} = 2.5V \sim 5.5V$	0.8	1	1.5	μA
FBD Regulation Voltage	V_{FBD}	$T_a = -20^\circ C \sim +85^\circ C$	0.784	0.8	0.816	V
FBD input Current	I_{FBD}	FBD=0.8V	-	-	100	nA
Current-Sense Amplifier Transresistance	R_{CS}		-	0.6	-	V/A
Transconductance	G_{MEA}		-	140	-	μs
Maximum Duty Cycle	D_{MAX}	FBD=0.7V	-	100	-	%

LX Leakage Current	I_{LX2}	$V_{LX}=0\sim 3.6V, PVCC2=3.6V$	-	1	5	μA
Switch On-Resistance	R_N	N-Channel	-	95	150	$m\Omega$
	R_P	P-Channel	-	150	250	$m\Omega$
P-Channel Current Limit	I_{Limit2}		1.0	1.2	1.4	A
N-Channel Turn-off Current	I_{REV2}		-	20	-	mA
/SDOK Output Low Voltage	V_{SDOK}	0.1mA into /SDOK	-	0.01	0.1	V
/SDOK Leakage current	I_{L_SDOK}	CTLD=0V,/SDOK=5.5V	-	0.1	1	μA
CHANNEL 3						
Input Voltage Range	PVCC3	Channel 3 DC/DC	1.2	-	6.0	V
Normal Operating Soft-Start Charge Current	I_{SS3}	$V_{CC}=2.5V\sim 5.5V$	0.8	1	1.5	μA
FB3 input Current	I_{FB3}	FB3=0.8V	-	-	100	nA
FB3 Regulation Voltage	V_{FB3}	$T_a=-20^{\circ}C\sim +85^{\circ}C,$ FB3=COMP3	0.784	0.8	0.816	V
Error Amplifier Voltage Gain	AV	DC	80	-	-	dB
Error Amplifier Frequency Bandwidth	BW	AV=0dB	-	5	-	MHz
Error Amplifier Output Voltage	V_{OH}		-	1.0	-	V
	V_{OL}		-	10	-	mV
Error Amplifier Output Source Current	I_{source}	COMP=0.8V	-	-0.5	-	mA
	I_{sink}	COMP=0.8V	-	60	-	μA
Output Source Current	I_{source}	DUTY=90%,OUT=1/2VCC	-	-130	-80	mA
Output Sink Current	I_{sink}	DUTY=0%,OUT=1/2VCC	65	100	-	mA
Output On-Resistor	R_{OH}	OUT=-15mA	-	18	30	Ω
	R_{OL}	OUT=15mA	-	16	25	Ω
Maximum Duty Cycle	D_{MAX}	Step-Up Mode	85	90	95	%
	D_{MAX}	Step-Down Mode	-	100	-	%
CHANNEL 4,5,6						



圓創科技股份有限公司

AT1396A/B/C/D

Preliminary Product Information 6-Channel DC-DC Converter for DSC

Input Voltage Range	PVCC4	Channel 4,5,6 DC/DC	1.2	-	6.0	V
Normal Operating Soft-Start Charge Current	$I_{SS4/5/6}$	$V_{CC}=2.5V\sim 5.5V$	0.8	1	1.5	μA
FB4/5/6 Regulation Voltage	$V_{FB4/5/6}$	$T_a=-20^{\circ}C\sim +85^{\circ}C$, FB_=COMP_	0.784	0.8	0.816	V
FB5 Regulation Voltage for LED Driver	V_{FB5}	$T_a=-20^{\circ}C\sim +85^{\circ}C$, FB5=COMP5	0.19	0.20	0.21	V
FB5H OVP Trip Level	V_{FB5H}	$T_a=-20^{\circ}C\sim +85^{\circ}C$,	0.98	1.00	1.02	V
Error Amplifier Voltage Gain	AV	DC	80	-	-	dB
Error Amplifier Frequency Bandwidth	BW	AV=0dB	-	5	-	MHz
Error Amplifier Output Voltage	V_{OH}		-	1.0	-	V
	V_{OL}		-	10	-	mV
Error Amplifier Output Source Current	I_{source}	COMP=0.8V	-	-0.5	-	mA
	I_{sink}	COMP=0.8V	-	60	-	μA
Maximum Duty Cycle	D_{MAX}	FB_=0.7V	85	90	95	%
	D_{MAX}	FB5=0.1V	85	90	95	%
Output Source Current	I_{source}	DUTY=90%,OUT=1/2VCC	-	-130	-80	mA
Output Sink Current	I_{sink}	DUTY=0%,OUT=1/2VCC	65	100	-	mA
Output On-Resistor	R_{OH}	OUT=-15mA	-	18	30	Ω
	R_{OL}	OUT=15mA	-	16	25	Ω
SHORT CIRCUIT PROTECTION						
Threshold Voltage	V_{TH}	CH3,CH4,CH5,CH6	-	0.9	-	V
CSCP Charge Current	I_{CSCP}		0.8	1.0	1.5	μA
CONTROL BLOCK						
CTLU input Voltage	V_{IH}	PVCC1=VCC=1.5 ~5.5V	1.1	-	VCC	V
	V_{IL}	PVCC1=VCC=1.5 ~5.5V	0	-	0.5	V
CTLD input Voltage	V_{IH}	PVCC1 , 2=VCC=1.5 ~5.5V CTLD= V_{IH}	1.1	-	VCC	V
	V_{IL}	PVCC1 , 2=VCC=1.5 ~5.5V CTLD= V_{IH}	0	-	0.5	V



圓創科技股份有限公司

AT1396A/B/C/D

Preliminary Product Information 6-Channel DC-DC Converter for DSC

CTL3 input Voltage	V _{IH}	PVCC1 , 3=VCC=1.5 ~5.5V CTLU=V _{IH}	1.4	-	VCC	V
	V _{IL}	PVCC1 , 3=VCC=1.5 ~5.5V CTLU=V _{IH}	0	-	0.5	V
CTL4 , 5 , 6 input Voltage	V _{IH}	PVCC1 , 4=VCC=1.5 ~5.5V CTLU=V _{IH}	1.4	-	VCC	V
	V _{IL}	PVCC1 , 4=VCC=1.5 ~5.5V CTLU=V _{IH}	0	-	0.5	V
SEL4 input Voltage	V _{IH}	PVCC1 , 4=VCC=1.5 ~5.5V CTLU=CTL4=V _{IH}	1.4	-	VCC	V
	V _{IL}	PVCC1 , 4=VCC=1.5 ~5.5V CTLU=CTL4=V _{IH}	0	-	0.5	V

Typical Characteristics

CH1 Efficiency VS. Load Current

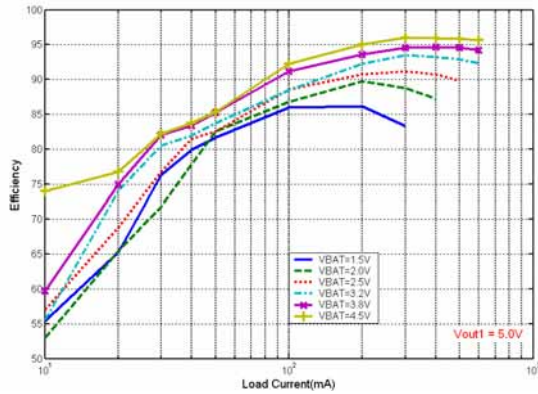

CH3 Efficiency VS. Load Current

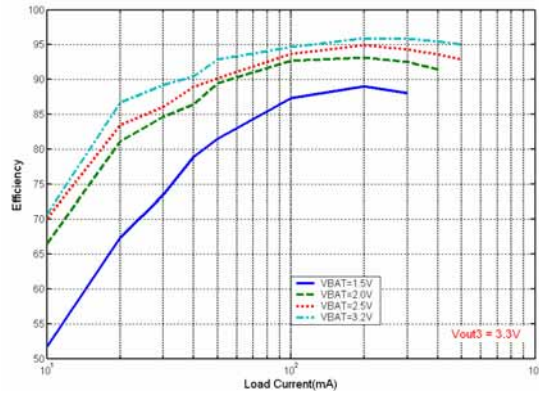

CH1 + CH2 Efficiency VS. Load Current

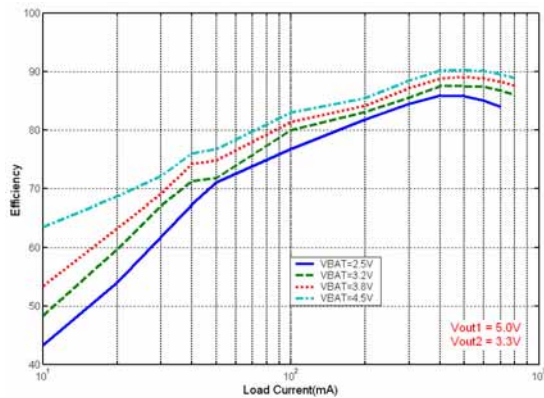

CH2 Efficiency VS. Load Current

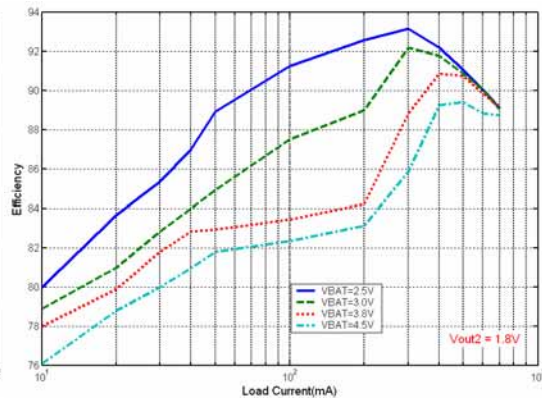

CH1 + CH2 Efficiency VS. Load Current

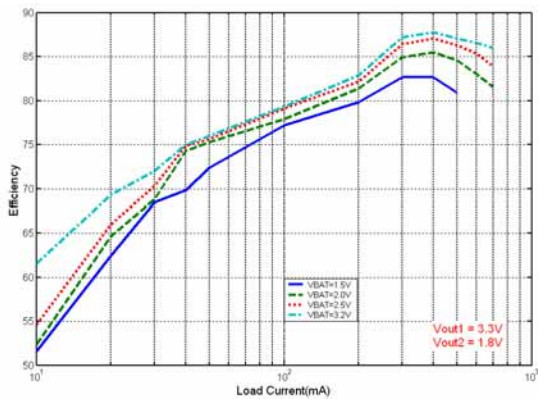

CH4 , 5 , 6 Efficiency VS. Load Current

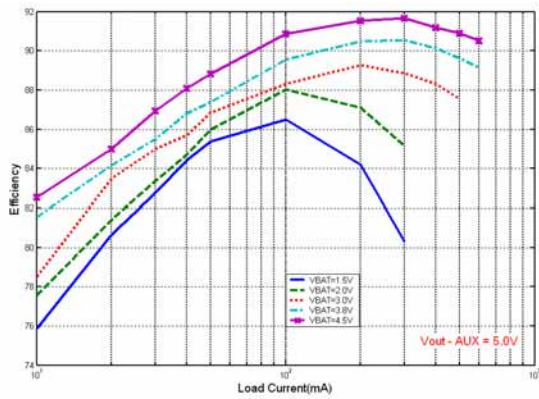

CH4 , 5 , 6 Efficiency VS. Load Current

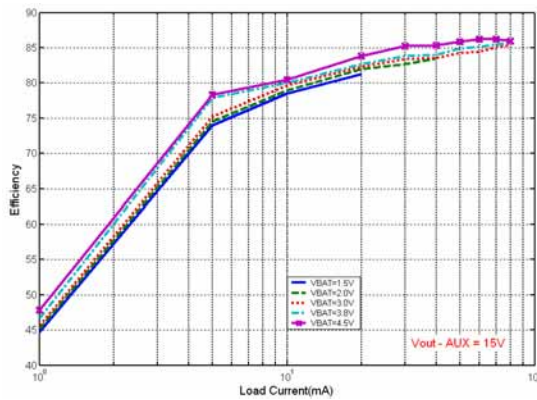

CH4 , 5 , 6 Efficiency VS. Load Current

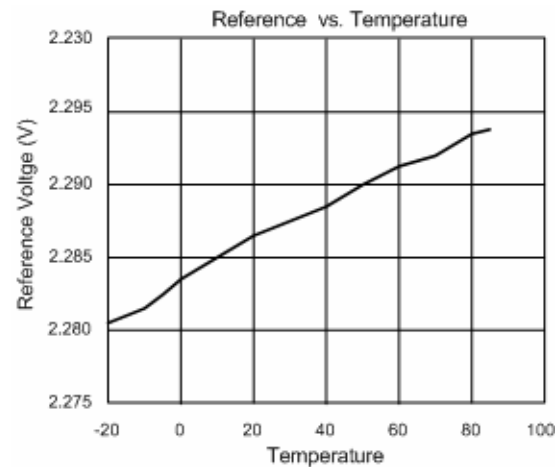
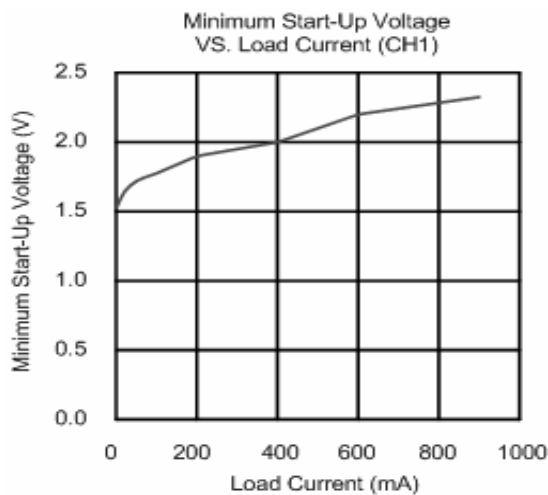
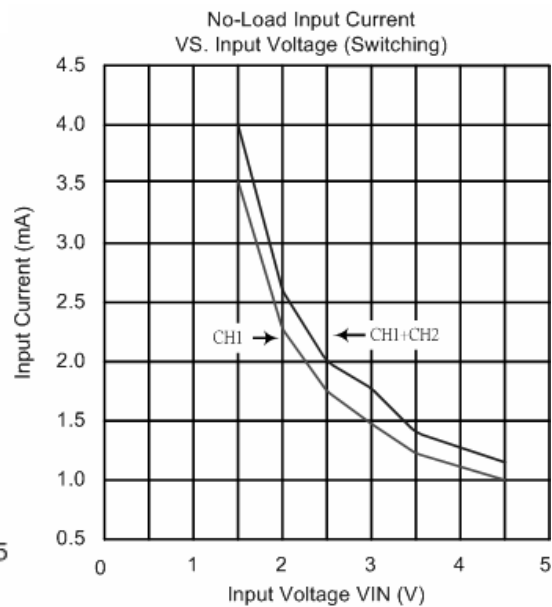
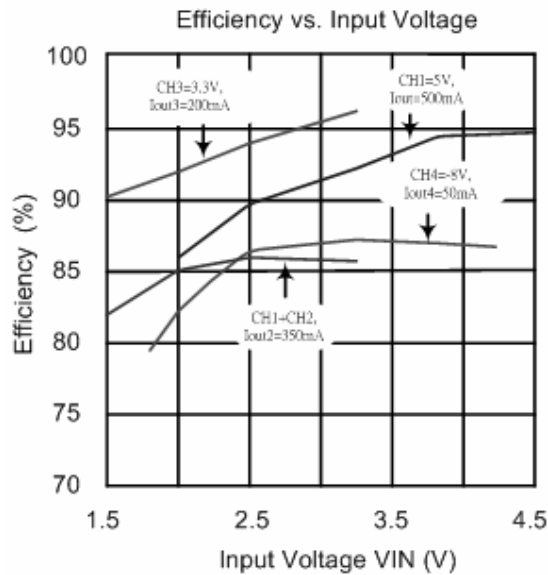
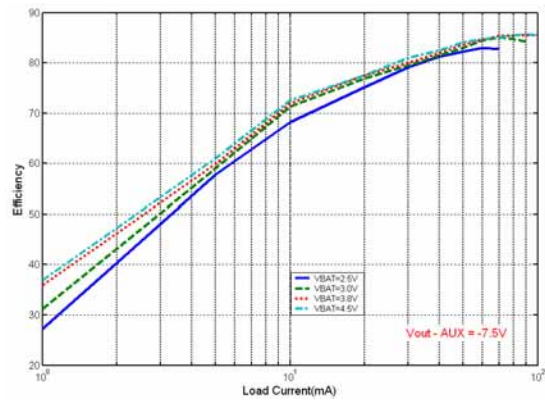

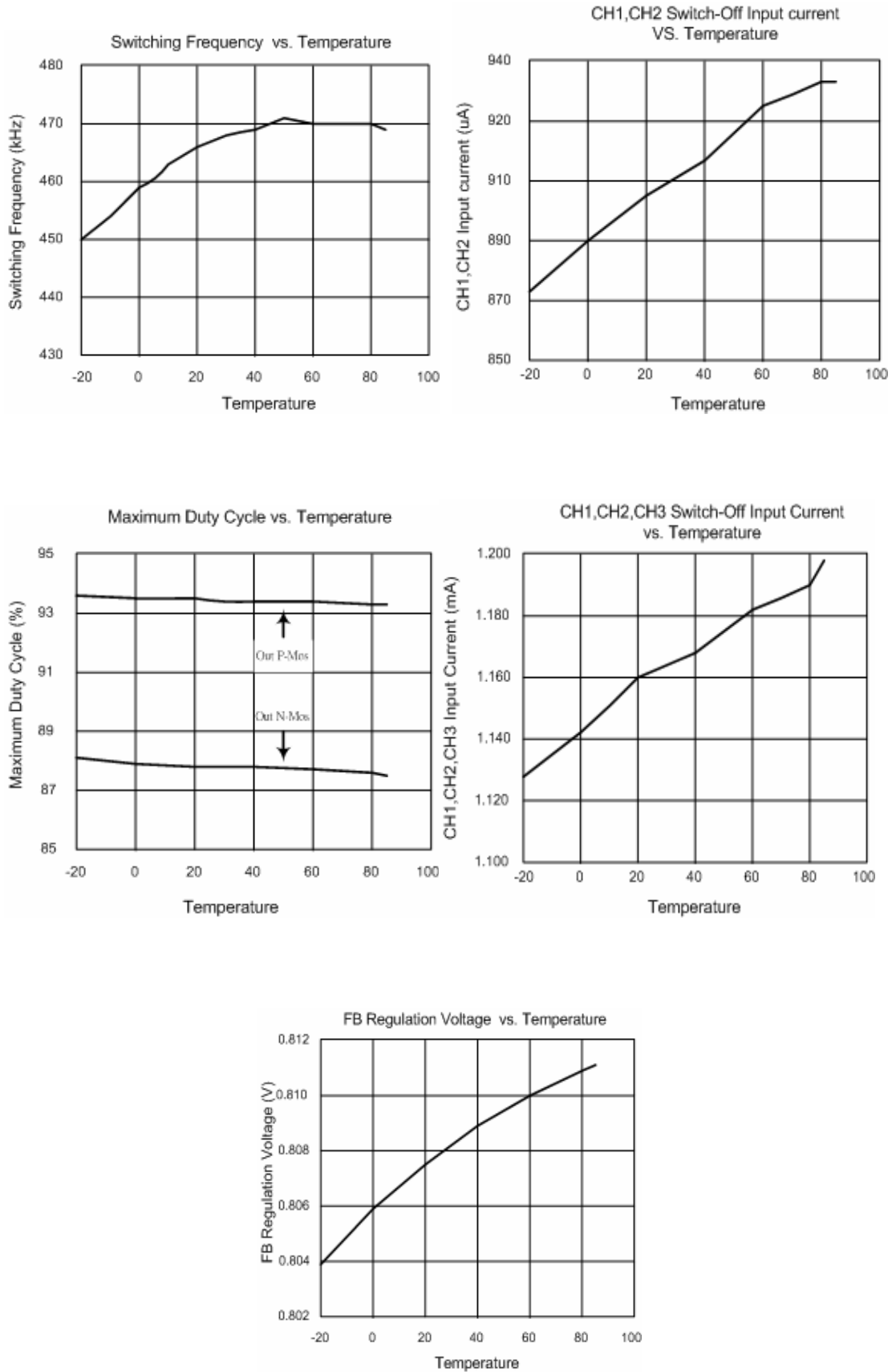

CH3 Start-Up Waveform

VBAT = 2.0V

Time : 20mS/Div

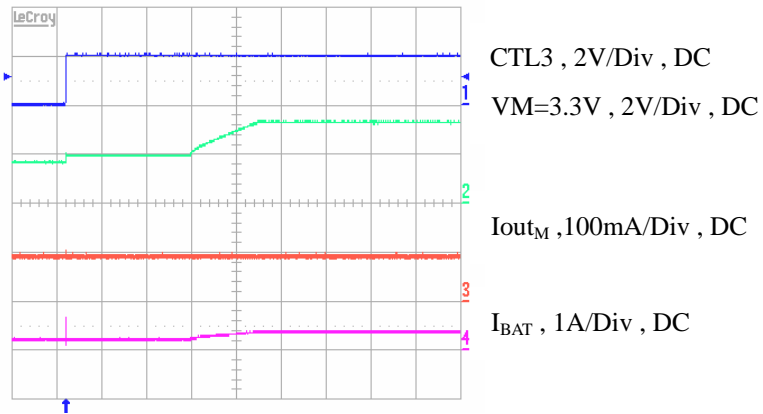

CH3 Start-Up Waveform

VBAT = 3.0V

Time : 20mS/Div

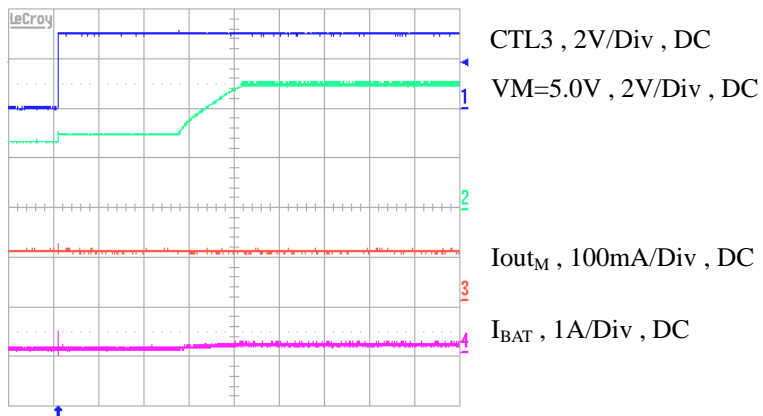

CH1,CH2,CH3 Start-Up Waveform

VBAT = 3.0V

Time : 50mS/Div

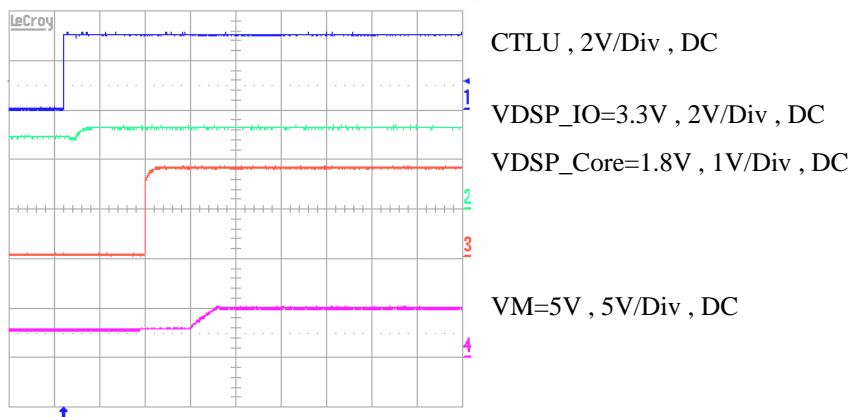

CH1 Load Transient Response

VBAT = 3.0V

Time : 1mS/Div

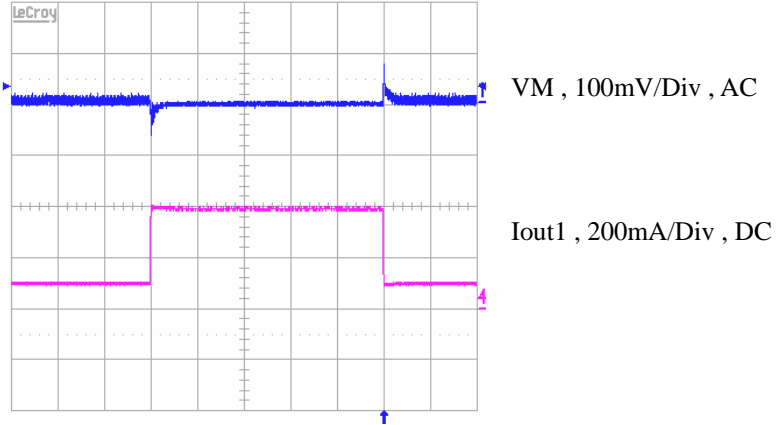

CH2 Load Transient Response

VBAT = 2.0V

Time : 1mS/Div

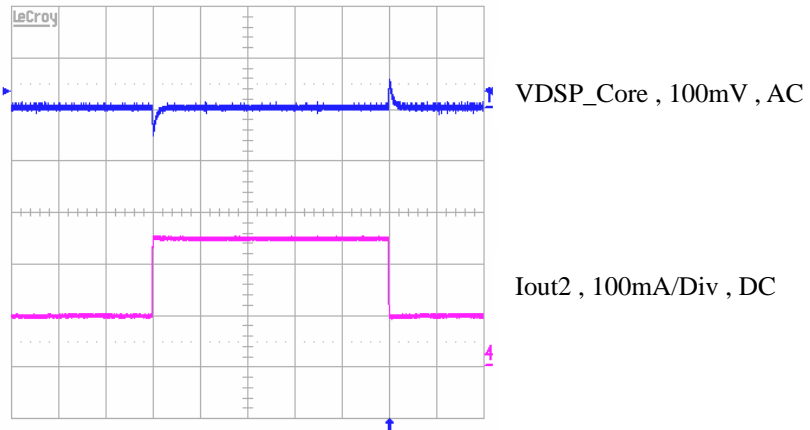

CH3 Load Transient Response

VBAT = 3.0V

Time : 1mS/Div

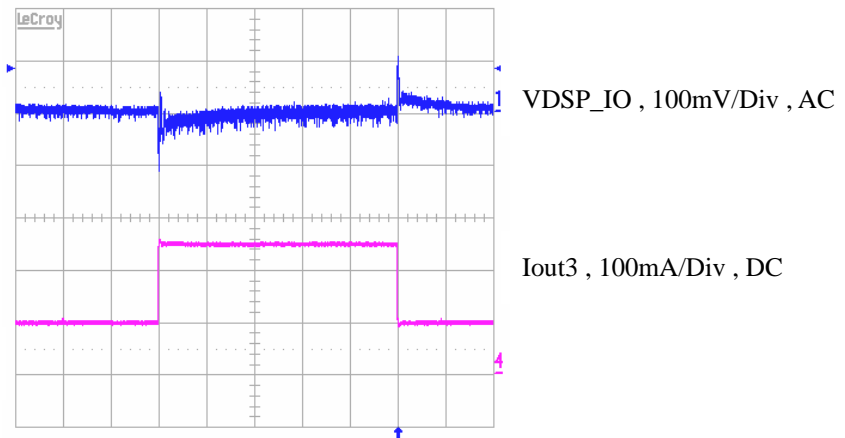

Typical Application Circuit

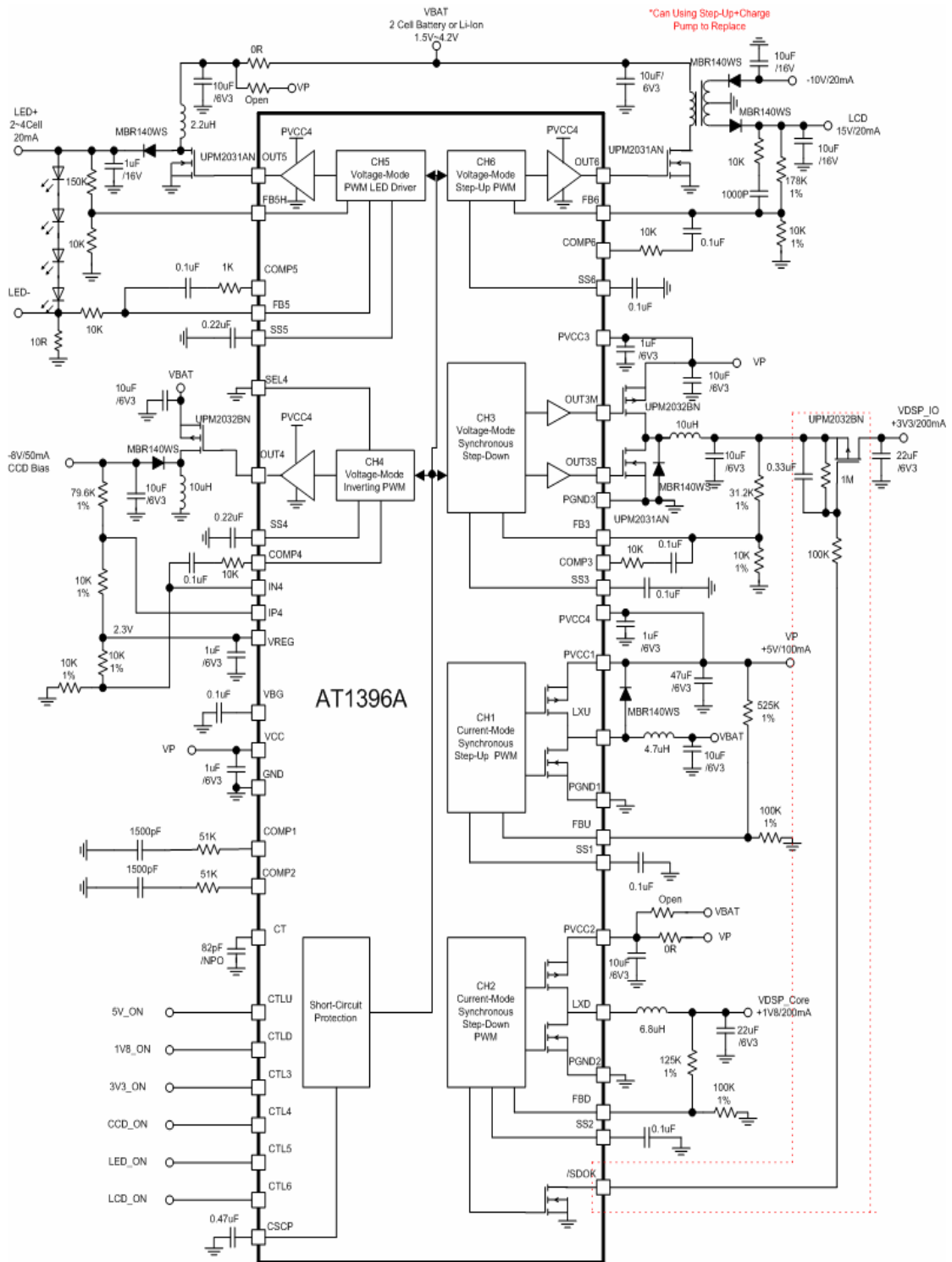

*If CH5 not for LED Driver, Change to use AT1396C

Multi-Battery Application

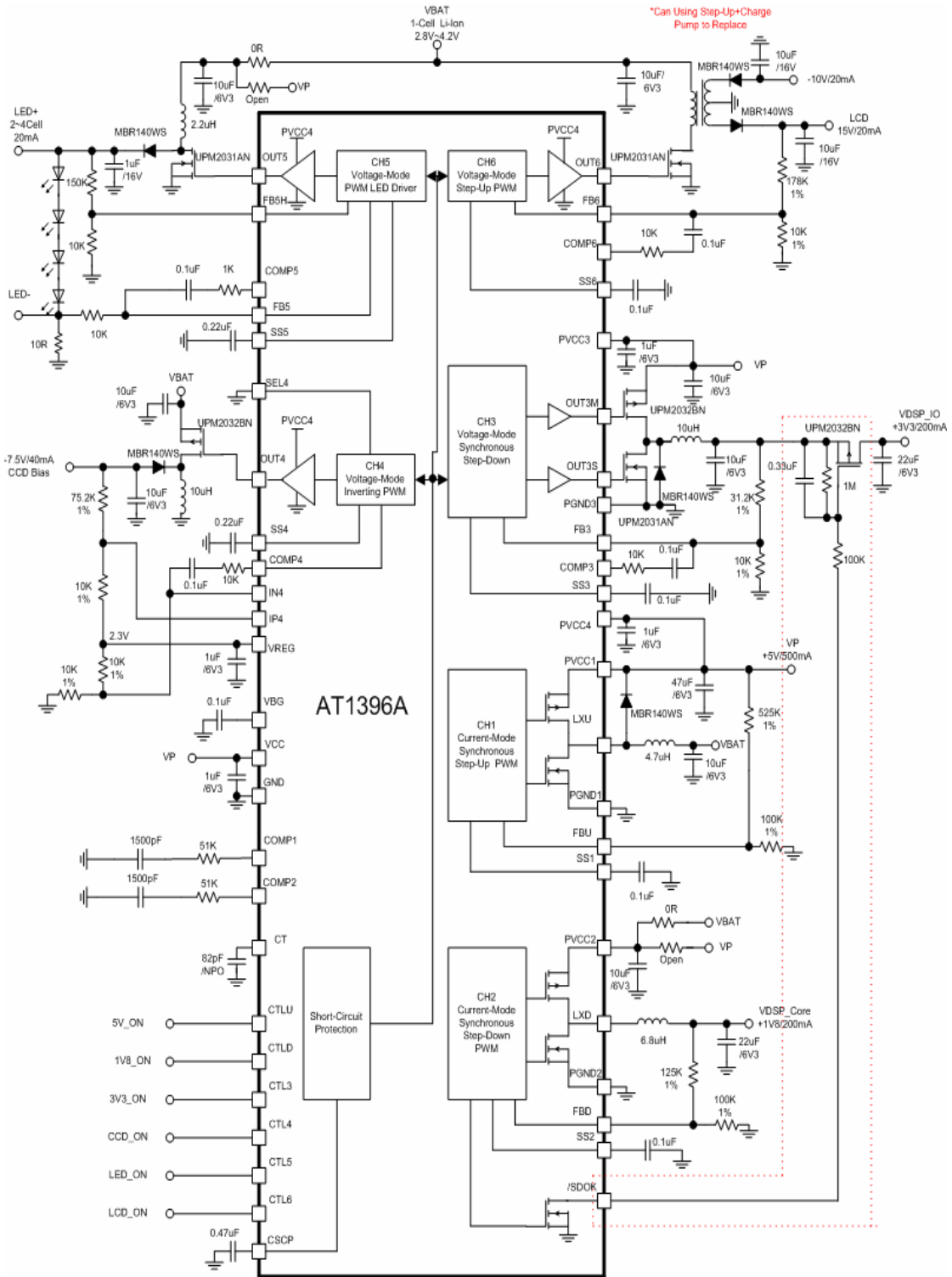

* If CH5 not for LED Driver, Change to use AT1396C

1-Li Battery Application

Application Information

The AT1396A/B/C/D include 6 channels DC/DC to generate a multiple-output digital camera power-supply system. It include:

- Step-Up DC/DC converter with on-chip synchronous MOSFETs.(CH1)
- Step-Down DC/DC converter with on-chip synchronous MOSFETs.(CH2)
- Main synchronous DC/DC controller can be configured as either a Step-Up or Step-Down converter.(CH3)
- Selectable DC/DC controller for boost/flyback/buck/inverting converters.(CH4)
- White LED driver with open LED protection or boost controller.(CH5)
- Boost/flyback controller.(CH6)

Step-Up DC/DC Converter (CH1)

The step-up DC/DC converter typically is used to generate a 5V or the highest of the DSC power system requirement from a 1.5V to 4.2V battery input and self-power the AT1396. The efficiency is up to 95% with an internal MOSFET and external synchronous rectifier.

Step-Down DC/DC Converter (CH2)

The step-down DC/DC is optimized for generating DSP core voltage (down to 0.8V) at high efficiency. It runs from the voltage at PVCC2. This pin can be connected directly to the battery if sufficient headroom exists to avoid dropout. It can be powered from the output of another converter (CH1 or CH3) for boost-buck operation.

The CH2 also features an open-drain /SDOK output that goes low when the CH2 is in regulation. /SDOK may be used to drive an external P-MOSFET that gates 3.3V power to the DSP after the core voltage is in regulation (Figure 1). The R1,R2 and C1 is for MOSFET soft-start function to avoid the more inrush current .

Step-Up or Step-Down DC/DC Converter (CH3)

The CH3 can be as a step-up (AT1396B/D) or step-down (AT1396A/C) voltage mode PWM converter. An external MOSFET and synchronous rectifier allow conversion efficiencies as high as 93%. Step-down operation can be direct from Li-Ion cell if the minimum input voltage exceeds the desired output by approximately 200mV. When

Auxiliary Controller (CH4,CH5,CH6)

The three auxiliary controllers operate as fixed-frequency voltage-mode PWM controllers. They use the external MOSFETs, so output power is determined by external components. All of auxiliary controllers have a guaranteed duty cycle of minimum duty cycle of 85%(boost-type) or 100%(buck/inverting type). In boost designs that employ continuous current (CCM), the maximum duty cycle limits the boost ratio so:

$$1 - \frac{V_{IN}}{V_{OUT}} \leq 85\%$$

With discontinuous inductor current(DCM), no such limit exists for the input/output ratio since the inductor has time to fully discharge before the next cycle begins. The discontinuous conduction mode boost voltage conversion relationship is given by:

$$V_o = V_i \times \frac{1 + \sqrt{1 + \frac{4 \times D^2}{K}}}{2} \quad D = \sqrt{K \times M \times (M - 1)}$$

Where K is defined as:

$$K = \frac{2 \times L}{R \times T_s} \quad M = \frac{V_o}{V_i}$$

The CH4 is selectable DC/DC controller for drive N-channel MOSFETs (SEL=high) or P-channel MOSFETs (SEL=low). It can be configure as the inverting circuit (Figure 2), typically for CCD and LCD bias. This is useful in height-Limited designs where transformers may not be desired. The efficiency is more than the charge-pump inversion for some load conditions.

The CH5 can be configure as a switching-mode boost current source for white LEDs, FB5(0.2V) provides current-sensing feedback, while FB5H(1.0V) provides (optional) open-LED over-voltage protection(Figure 3). If used as a boost converter, FB5H is grounded and FB5(0.8V) is used as the feedback input. In this case, CH5 behaves exactly like CH4 and CH6.

The CH6 can be used for conventional DC/DC boost and flyback designs.(Figure 4 ,Figure 5 and Figure 6)

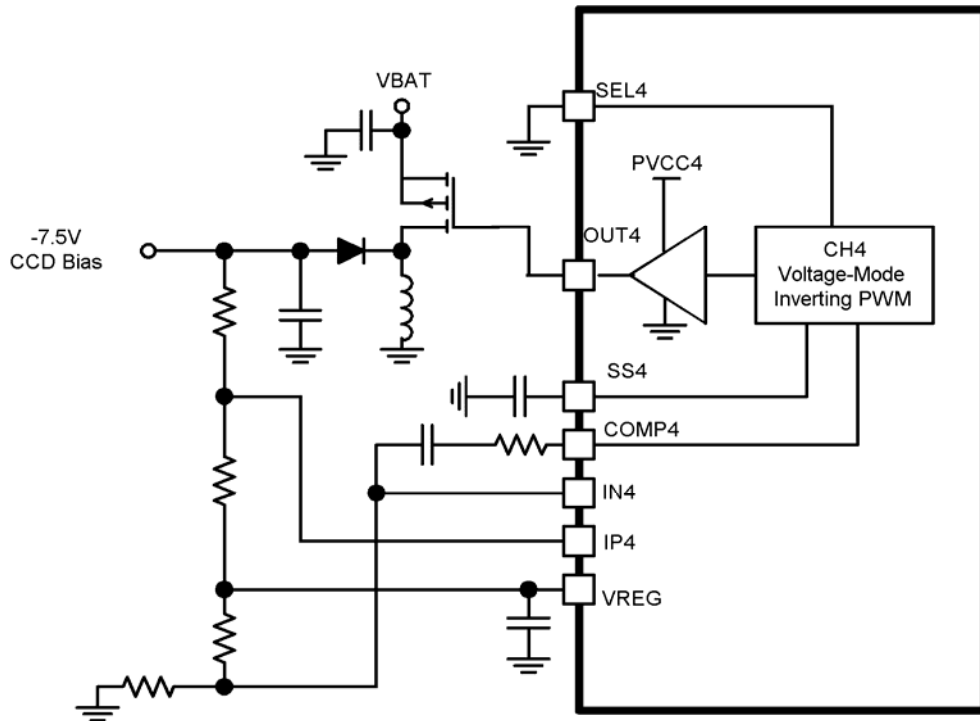

Figure 2. Regulated -7.5V negative CCD Bias.

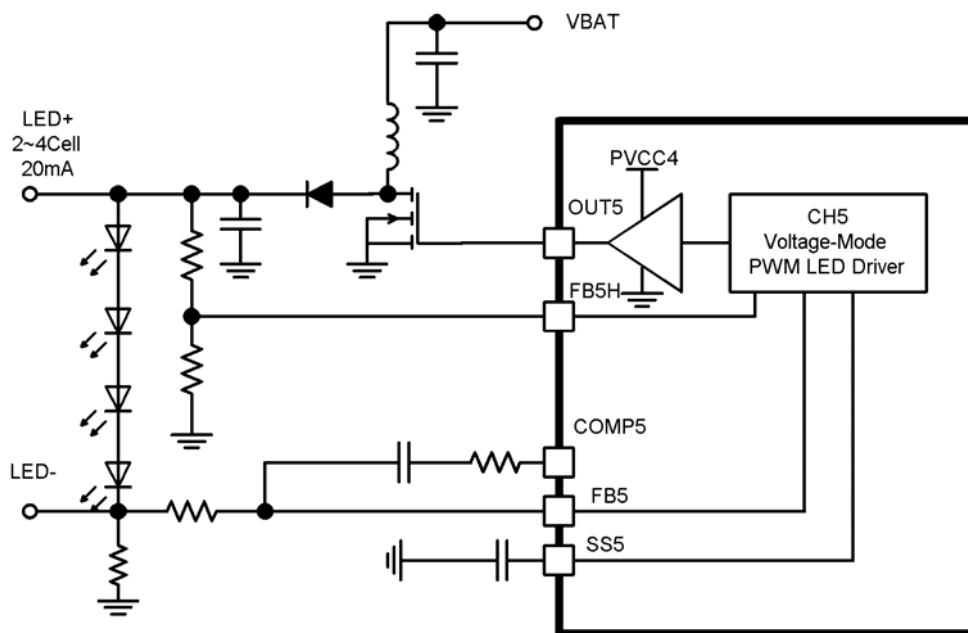

Figure 3. LED Drive with open LED over-voltage protection

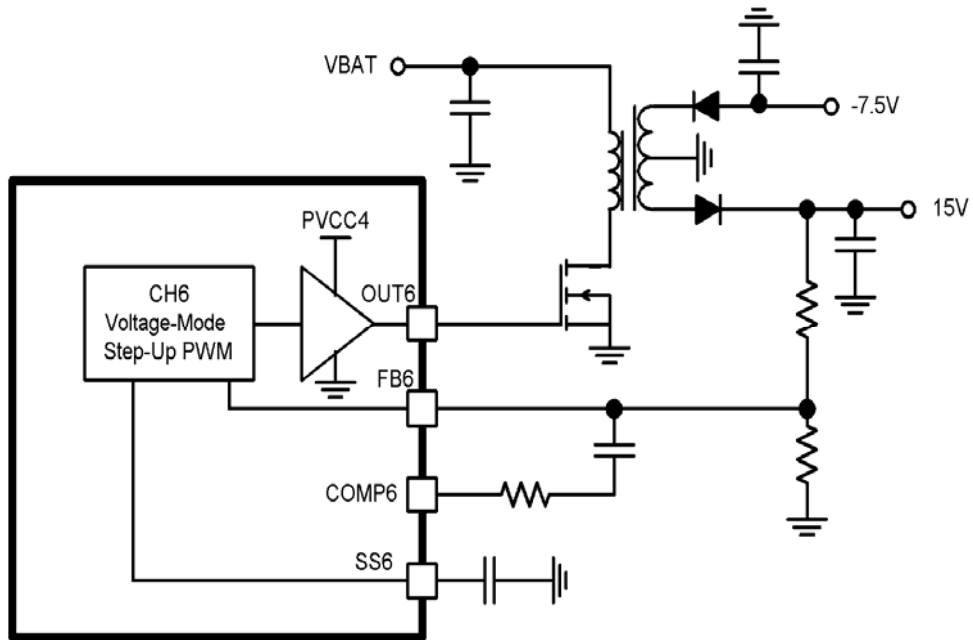

Figure 4. +15V and -7.5V CCD Bias with transformer

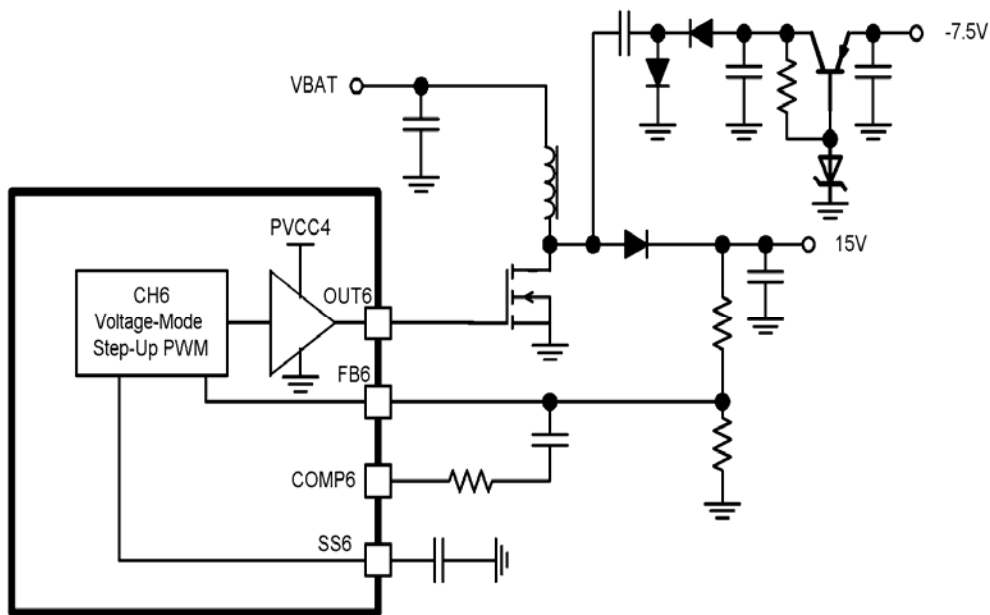

Figure 5. +15V and -7.5V CCD Bias with Charge-Pump Inversion

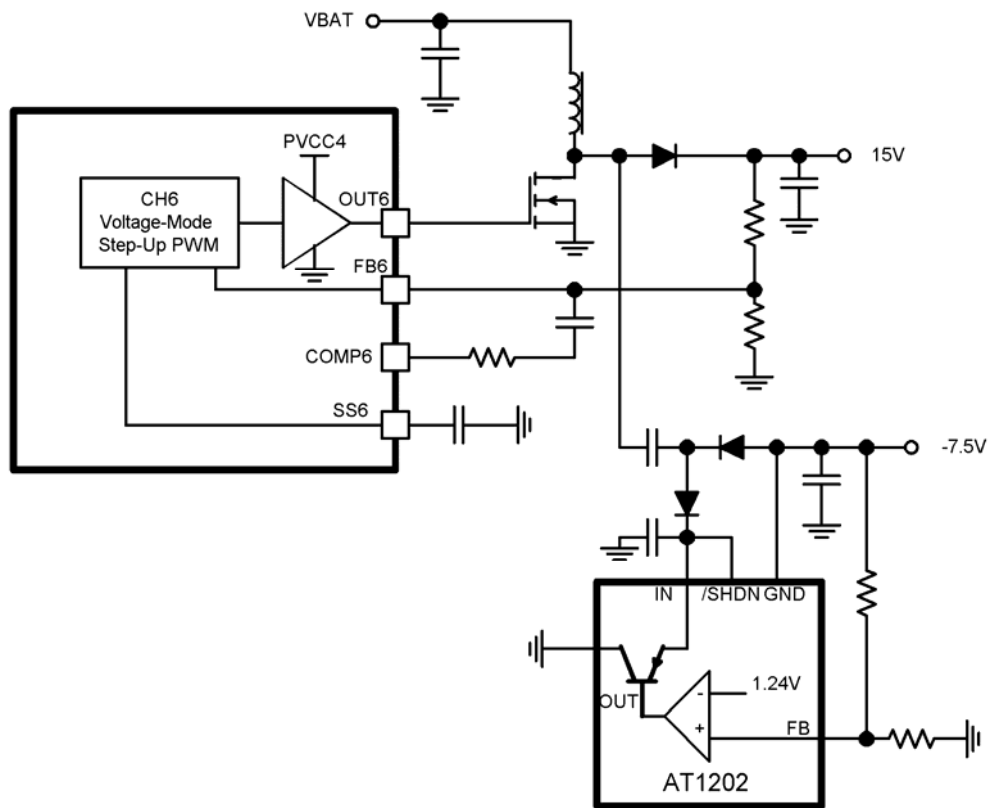

Figure 6. +15V and -7.5V CCD Bias with Charge-Pump (using AT1202 to regulated the negative output)

Soft-Start Setting (CH1~CH6)

The AT1396 all channels feature a soft-start function that limits inrush current and prevents excessive battery loading at start-up by ramping the output voltage of each channel up to the regulation voltage. Consider the input voltage and load current to design the capacitor connected to the SS pin. It can calculate the CH1~6 soft start time $T_s(s)$ (valid threshold 0.3~0.8V interval).

$$C \times \frac{\Delta V}{\Delta t} = I$$

$$T_s(s) = 0.5 \times C(\mu F)$$

Note : It could be disabled soft start function by floating SS pin.

SCP Protection Setting (CH3~CH6)

The CSCP comparator detects CH3,CH4,CH5 and CH6 output voltage while the power converter work at normal condition. At the same time, the voltage level of CSCP pin is held at low level. If the output load of these converters rapidly malfunction or short, causing the output voltage to drop, the CSCP comparator detects that to enable short circuit protection. The time period when short circuit protection show as follow equation.

Short detection time ($T_{PE}(s)$)

$$T_{PE}(s) = 0.9 * C_{CSCP} (\mu F)$$

Note : It could be disabled short circuit protection function by connecting CSCP pin into the ground.

Determine the triangular Oscillator Frequency

The triangular oscillator frequency is determined by the timing capacitor (C_T). It is difficult to incorporate these non-linear characteristics into the equation. This difference is caused by characteristics, such as changes in the maximum voltage amplitude of the sawtooth waveform with the C_T value and the circuit delay causing the maximum amplitude to become large in the case of a high oscillating frequency even for the same capacitor. In practical use, therefore, the user should read the C_T values from the characteristic curve or should determine an approximate target value by using the equation.

$$f_{osc}(KHz) = \frac{41000}{C_T(pF)}$$

Package Outline: QFN48

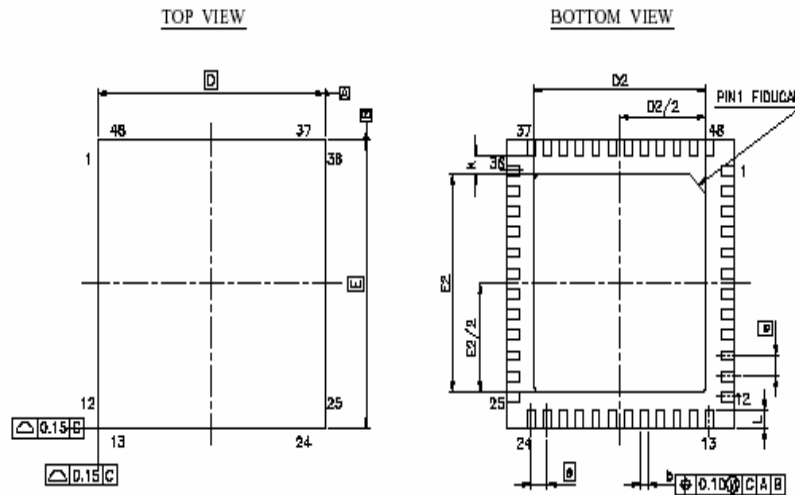

SYMBOL	DIMENSION (MM)			DIMENSION (MIL)		
	MIN.	NOM.	MAX.	MIN.	NOM.	MAX.
A	0.70	0.75	0.80	27.6	29.5	31.5
A1	0	0.02	0.05	0	0.79	1.97
A3	0.203 REF			8 REF		
b	0.19	0.23	0.30	7.1	9.1	11.8
D	7.00 BSC			276 BSC		
D2	5.10	5.30	5.50	201	209	217
E	7.00 BSC			276 BSC		
E2	5.10	5.30	5.50	201	209	217
e	0.50 BSC			19.7 BSC		
k	0.20			7.9		
L	0.30	0.40	0.50	11.8	15.7	19.7
y	0.08			3.15		

