

**Clock Generator for Intel  
PCI-Express Server Chipset**
**Features**

- 14.318 MHz Crystal Input
- Selectable of 100, 133, 166, 200, 266, 333, and 400 MHz CPU Output Frequencies
- SMBus: Power Management Control
- Spread Spectrum support (-0.5% down spread)
- Packaging (Pb-free & Green):
  - 56-Pin SSOP (V)
  - 56-Pin TSSOP (A)

**Output Features**

- Four Pairs of Differential CPU Clocks
- Five Pairs of SRC Clocks
- Seven PCI Clocks
- One 48 MHz USB clock
- Two REF clocks

**Description**

PI6C410B is a high-speed, low-noise clock generator designed to work with Intel Server PCI-Express Chipset. The Spread Spectrum PLL based clock generator reduces EMI emission and supports a wide range of frequencies.

**Jitter Performance**

- < 85ps Cycle-to-Cycle CPU clock jitter
- < 350ps Cycle-to-Cycle 48MHz clock jitter
- < 500ps Cycle-to-Cycle PCI clock jitter
- < 125ps Cycle-to-Cycle SRC clock jitter
- < 1000ps Cycle-to-Cycle REF clock jitter

**Skew Performance**

- < 100ps Output to output CPU clock skew
- < 500ps Output to output PCI clock skew
- < 250ps Output to output SRC clock skew

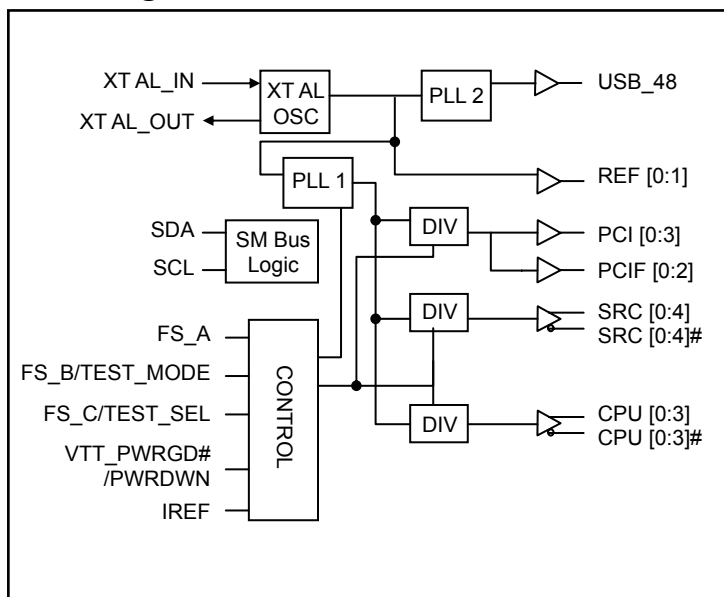
**Block Diagram**

**Pin Configuration**

VDD_PCI	1	56	FS_C / TEST_SEL
VSS_PCI	2	55	REF_0
PCI_0	3	54	REF_1
PCI_1	4	53	VDD_REF
PCI_2	5	52	XTAL_IN
PCI_3	6	51	XTAL_OUT
VSS_PCI	7	50	VSS_REF
VDD_PCI	8	49	FS_B/TEST_MODE
PCIF_0	9	48	FS_A
PCIF_1	10	47	VDD_CPU
PCIF_2	11	46	CPU_0
VDD_48	12	45	CPU_0#
USB_48	13	44	VDD_CPU
VSS_48	14	43	CPU_1
VDD_SRC	15	42	CPU_1#
SRC_0	16	41	VSS_CPU
SRC_0#	17	40	CPU_2
SRC_1#	18	39	CPU_2#
SRC_1	19	38	VDD_CPU
VSS_SRC	20	37	CPU_3
SRC_2	21	36	CPU_3#
SRC_2#	22	35	VDD_A
SRC_3#	23	34	VSS_A
SRC_3	24	33	IREF
VDD_SRC	25	32	NC
SRC_4	26	31	VTT_PWRGD# / PWRDWN
SRC_4#	27	30	SDA
VDD_SRC	28	29	SCL

### Pin Descriptions

Pin Name	Type	Pin No	Descriptions
REF[0:1]	Output	54, 55	3.3V 14.31818 MHz outputs
XTAL_IN	Input	52	14.31818 MHz crystal input
XTAL_OUT	Output	51	14.31818 MHz crystal output
CPU[0:3] & CPU[0:3]#	Output	36, 37; 39, 40; 42, 43; 45, 46	Differential CPU outputs
SRC[0:4] & SRC[0:4]#	Output	16, 17; 18, 19; 21, 22; 23, 24; 26, 27	Differential Serial Reference Clock outputs
PCIF[0:2]	Output	9, 10, 11	33 MHz clocks outputs (free running)
PCI[0:3]	Output	3, 4, 5, 6	33 MHz clocks outputs
USB_48	Output	13	48 MHz clock output
FS_A	Input	48	3.3V LVTTTL inputs for CPU frequency selection
FS_B / TEST_MODE	Input	49	3.3V LVTTTL inputs for CPU frequency selection / Test Mode select: 0 = Hi-Z, 1 = Ref/N
FS_C / TEST_SEL	Input	56	3.3V LVTTTL inputs for CPU frequency selection / Test Mode select if pulled to 3.3V when Vtt_PwrGD# is asserted LOW
IREF	Input	33	External resistor connection for internal current reference
VTT_PWRGD# / PWRDWN	Input	31	3.3V LVTTTL Level sensitive strobe used to determine to latch the FS_A, FS_B/TEST_MODE and FS_C/TEST_SEL inputs (active low) / 3.3V LVTTTL active high input for Power Down operation.
SDA	I/O	30	SMBus compatible SDATA
SCL	Input	29	SMBus compatible SCLOCK
VDD_PCI	Power	1, 8	3.3V Power Supply for Outputs
VDD_48	Power	12	3.3V Power Supply for Outputs
VDD_SRC	Power	15, 25, 28	3.3V Power Supply for Outputs
VDD_CPU	Power	38, 44, 47	3.3V Power Supply for Outputs
VDD_REF	Power	53	3.3V Power Supply for Outputs
VSS_PCI	Ground	2, 7	Ground for Outputs
VSS_48	Ground	14	Ground for Outputs
VSS_SRC	Ground	20	Ground for Outputs
VSS_CPU	Ground	41	Ground for Outputs
VSS_REF	Ground	50	Ground for Outputs
VDD_A	Power	35	3.3V Power Supply for PLL
VSS_A	Ground	34	Ground for PLL

## Functionality

### Frequency Selection

FS_C	FS_B	FS_A	CPU	SRC	PCIF / PCI	REF	USB_48	Note
1	0	1	100 MHz	100 MHz	33 MHz	14.318 MHz	48 MHz	1
0	0	1	133 MHz	100 MHz	33 MHz	14.318 MHz	48 MHz	1
0	1	1	166 MHz	100 MHz	33 MHz	14.318 MHz	48 MHz	1
0	1	0	200 MHz	100 MHz	33 MHz	14.318 MHz	48 MHz	1
0	0	0	266 MHz	100 MHz	33 MHz	14.318 MHz	48 MHz	1
1	0	0	333 MHz	100 MHz	33 MHz	14.318 MHz	48 MHz	1
1	1	0	400 MHz	100 MHz	33 MHz	14.318 MHz	48 MHz	1
1	1	1	Reserved	100 MHz	33 MHz	14.318 MHz	48 MHz	1

**Notes:**

1. Refer to DC Electrical Characteristics for FS\_A, FS\_B and FS\_C (Vih\_FS, Vil\_FS) threshold levels

### Test Mode Selection

TEST_MODE	CPU	SRC	PCIF / PCI	REF	USB_48	Note
1	REF/N	REF/N	REF/N	REF	REF/N	2
0	Hi-Z	Hi-Z	Hi-Z	Hi-Z	Hi-Z	2

**Notes:**

2. Test mode will occur where the SMBus Bit 6 of Byte 6 = 1, or FS\_C/TEST\_SEL is set to logic high level.

### PWRDWN Functionality

PWRDWN	CPU	CPU#	SRC	SRC#	PCIF / PCI	REF	USB_48
0	Normal	Normal	Normal	Normal	33 MHz	14.318 MHz	48 MHz
1	Iref × 2 or Float	Float	Iref × 2 or Float	Float	Low	Low	Low

### Serial Data Interface (SMBus)

PI6C410B is a slave only SMBus device that supports indexed block read and indexed block write protocol using a single 7-bit address and read/write bit as shown below.

#### Address Assignment

A6	A5	A4	A3	A2	A1	A0	R/W
1	1	0	1	0	0	1	0/1

#### Data Protocol

1 bit	7 bits	1	1	8 bits	1	8 bits	1	8 bits	1		8 bits	1	1 bit
Start bit	Slave Addr	R/W	Ack	Register offset	Ack	Byte Count = N	Ack	Data Byte 0	Ack	...	Data Byte N - 1	Ack	Stop bit

**Note:**

1. Register offset for indicating the starting register for indexed block write and indexed block read. Byte Count in write mode cannot be 0.

#### Data Byte 0: Control Register

Bit	Descriptions	Type	Power-Up Condition	Output(s) Affected	Pin	Source Pin
0	SRC_0 Output Enable 1 = Enabled, 0 = Disabled (Hi-Z)	RW	1 = Enabled	SRC_0	17, 18	NA
1	SRC_1 Output Enable 1 = Enabled, 0 = Disabled (Hi-Z)	RW	1 = Enabled	SRC_1	19, 20	NA
2	SRC_2 Output Enable 1 = Enabled, 0 = Disabled (Hi-Z)	RW	1 = Enabled	SRC_2	22, 23	NA
3	SRC_3 Output Enable 1 = Enabled, 0 = Disabled (Hi-Z)	RW	1 = Enabled	SRC_3	24, 25	NA
4	SRC_4 Output Enable 1 = Enabled, 0 = Disabled (Hi-Z)	RW	1 = Enabled	SRC_4	26, 27	NA
5	Reserved	RW				
6	Reserved	RW				
7	Reserved	RW				

**Data Byte 1: Control Register**

Bit	Descriptions	Type	Power-Up Condition	Output(s) Affected	Pin	Source Pin
0	Spread Spectrum 1 = On, 0 = Off	RW	0 = Spread off	CPU[0:3], SRC[0:4], PCI[0:3], PCIF[0:2]	3, 4, 5, 6, 9, 10, 11, 16, 17, 18, 19, 21, 22, 23, 24, 26, 27, 36, 37, 39, 40, 42, 43, 45, 46	NA
1	CPU_0 output enable 1 = Enabled, 0 = Disabled (Hi-Z)	RW	1 = Enabled	CPU_0, CPU_0#	45, 46	NA
2	CPU_1 output enable 1 = Enabled, 0 = Disabled (Hi-Z)	RW	1 = Enabled	CPU_1, CPU_1#	42, 43	NA
3	Reserved	RW				
4	CPU_2 output enable 1 = Enabled, 0 = Disabled (Hi-Z)	RW	1 = Enabled	CPU_2, CPU_2#	39, 40	NA
5	CPU_3 output enable 1 = Enabled, 0 = Disabled (Hi-Z)	RW	1 = Enabled	CPU_3, CPU_3#	36, 37	NA
6	REF0 Output Enable 1 = Enabled, 0 = Disabled	RW	1 = Enabled	REF_0	55	NA
7	REF1 Output Enable 1 = Enabled, 0 = Disabled	RW	1 = Enabled	REF_1	54	NA

**Data Byte 2: Control Register**

Bit	Descriptions	Type	Power-Up Condition	Output(s) Affected	Pin	Source Pin
0	USB_48 Output Enable 1 = Enabled, 0 = Disabled	RW	1 = Enabled	USB_48	13	NA
1	PCIF_0 Output Enable 1 = Enabled, 0 = Disabled	RW	1 = Enabled	PCIF_0	9	NA
2	PCIF_1 Output Enable 1 = Enabled, 0 = Disabled	RW	1 = Enabled	PCIF_1	10	NA
3	PCIF_2 Output Enable 1 = Enabled, 0 = Disabled	RW	1 = Enabled	PCIF_2	11	NA
4	PCI_0 Output Enable 1 = Enabled, 0 = Disabled	RW	1 = Enabled	PCI_0	3	NA
5	PCI_1 Output Enable 1 = Enabled, 0 = Disabled	RW	1 = Enabled	PCI_1	4	NA
6	PCI_2 Output Enable 1 = Enabled, 0 = Disabled	RW	1 = Enabled	PCI_2	5	NA
7	PCI_3 Output Enable 1 = Enabled, 0 = Disabled	RW	1 = Enabled	PCI_3	6	NA

**Data Byte 3: Control Register**

Bit	Descriptions	Type	Power-Up Condition	Output(s) Affected	Pin	Source Pin
0	SRC_0 Output Control 0 = Free Running 1 = Stopped with PCI_STOP#	RW	0 = Free running	SRC_0, SRC_0#	16, 17	NA
1	SRC_1 Output Control 0 = Free Running 1 = Stopped with PCI_STOP#	RW	0 = Free running	SRC_1, SRC_1#	18, 19	NA
2	SRC_2 Output Control 0 = Free Running 1 = Stopped with PCI_STOP#	RW	0 = Free running	SRC_2, SRC_2#	21, 22	NA
3	SRC_3 Output Control 0 = Free Running 1 = Stopped with PCI_STOP#	RW	0 = Free running	SRC_3, SRC_3#	23, 24	NA
4	SRC_4 Output Control 0 = Free Running 1 = Stopped with PCI_STOP#	RW	0 = Free running	SRC_4, SRC_4#	26, 27	NA
5	PCIF0 Output Control 0 = Free Running 1 = Stopped with PCI_STOP#	RW	0 = Free running	PCIF_0	9	NA
6	PCIF1 Output Control 0 = Free Running 1 = Stopped with PCI_STOP#	RW	0 = Free running	PCIF_1	10	NA
7	PCIF2 Output Control 0 = Free Running 1 = Stopped with PCI_STOP#	RW	0 = Free running	PCIF_2	11	NA

**Data Byte 4: Control Register**

Bit	Descriptions	Type	Power-Up Condition	Output(s) Affected	Pin	Source Pin
0	CPU_0 Output Control 0 = Free Running 1 = Stopped with CPU_STOP#	RW	1 = Stopped with CPU_STOP# assertion	CPU_0, CPU0#	45, 46	NA
1	CPU_1 Output Control 0 = Free Running 1 = Stopped with CPU_STOP#	RW	1 = Stopped with CPU_STOP# assertion	CPU_1, CPU1#	42, 43	NA
2	CPU_2 Output Control 0 = Free Running 1 = Stopped with CPU_STOP#	RW	1 = Stopped with CPU_STOP# assertion	CPU_2, CPU2#	39, 40	NA
3	CPU_3 Output Control 0 = Free Running 1 = Stopped with CPU_STOP#	RW	1 = Stopped with CPU_STOP# assertion	CPU_3, CPU3#	36, 37	NA
4	CPU_0 Pwrdsn drive mode 1 = Hi-Z, 0 = Driven in Pwrdsn	RW	0 = Driven in power down	CPU_0, CPU0#	45, 46	NA
5	CPU_1 Pwrdsn drive mode 1 = Hi-Z, 0 = Driven in Pwrdsn	RW	0 = Driven in power down	CPU_1, CPU1#	42, 43	NA
6	CPU_2 Pwrdsn drive mode 1 = Hi-Z, 0 = Driven in Pwrdsn	RW	0 = Driven in power down	CPU_2, CPU2#	39, 40	NA
7	CPU_3 Pwrdsn drive mode 1 = Hi-Z, 0 = Driven in Pwrdsn	RW	0 = Driven in power down	CPU_3, CPU3#	36, 37	NA

**Data Byte 5: Control Register**

Bit	Descriptions	Type	Power-Up Condition	Output(s) Affected	Pin	Source Pin
0	CPU_0 CPU_Stop drive mode 1 = Hi-Z, 0 = Driven in CPU Stop	RW	0 = Driven in CPU_Stop	CPU_0, CPU0#	45, 46	NA
1	CPU_1 CPU_Stop drive mode 1 = Hi-Z, 0 = Driven in CPU Stop	RW	0 = Driven in CPU_Stop	CPU_1, CPU1#	42, 43	NA
2	CPU_2 CPU_Stop drive mode 1 = Hi-Z, 0 = Driven in CPU Stop	RW	0 = Driven in CPU_Stop	CPU_2, CPU2#	39, 40	NA
3	CPU_3 CPU_Stop drive mode 1 = Hi-Z, 0 = Driven in CPU Stop	RW	0 = Driven in CPU_Stop	CPU_3, CPU3#	36, 37	NA
4	Reserved	RW				
5	SRC_Pwrdsn drive mode 1 = Hi-Z, 0 = Driven in Pwrdsn	RW	0 = Driven in power down	SRC[0:4] & SRC[0:4]#	16, 17, 18, 19, 21, 22, 23, 24, 26, 27	NA
6	SRC_Stop drive mode 1 = Hi-Z, 0 = Driven in PCI_STOP	RW	0 = Driven in PCI_STOP	SRC[0:4] & SRC[0:4]#	16, 17, 18, 19, 21, 22, 23, 24, 26, 27	NA
7	Reserved	RW				

**Data Byte 6: Control Register**

Bit	Descriptions	Type	Power-Up Condition	Output(s) Affected	Pin	Source Pin
0	FS_A Reflects the value of the FS_A pin sampled on power up 0 = FS_A was low during Vtt_Pwrgd# assertion	R	Externally Selected	CPU[0:3]	36, 37, 39, 40, 42, 43, 45, 46	NA
1	FS_B Reflects the value of the FS_B pin sampled on power up 0 = FS_B was low during Vtt_Pwrgd# assertion	R	Externally Selected	CPU[0:3]	36, 37, 39, 40, 42, 43, 45, 46	NA
2	FS_C Reflects the value of the FS_C pin sampled on power up 0 = FS_C was low during Vtt_Pwrgd# assertion	R	Externally Selected	CPU[0:3]	36, 37, 39, 40, 42, 43, 45, 46	NA
3	PCI_Stop Output Control 0 = Enabled, all stoppable PCI and SRC clocks are stopped, 1 = Disabled	RW	1 = Disabled	All PCI & SRC clocks except PCIF and SRC clocks set to free-running	3, 4, 5, 6, 16, 17, 18, 19, 21, 22, 23, 24, 26, 27	NA
4	REF Output Drive Strength 0 = 1X, 1 = 2X	RW	1 = 2X	REF_0, REF_1	54, 55	NA
5	Reserved	RW				
6	Test Clock Mode Entry Control 0 = Normal, 1 = REF/N or Hi-Z	RW	0 = Disabled			
7	Test Clock Mode 0 = Hi-Z, 1 = REF/N	RW	0 = Hi-Z			NA

**Data Byte 7: Pericom ID Register**

Bit	Descriptions	Type	Power-Up Condition	Output(s) Affected	Pin
0	Vendor ID	R	0	NA	NA
1		R	0	NA	NA
2		R	0	NA	NA
3		R	0	NA	NA
4	Revision Code	R	1	NA	NA
5		R	0	NA	NA
6		R	1	NA	NA
7		R	0	NA	NA

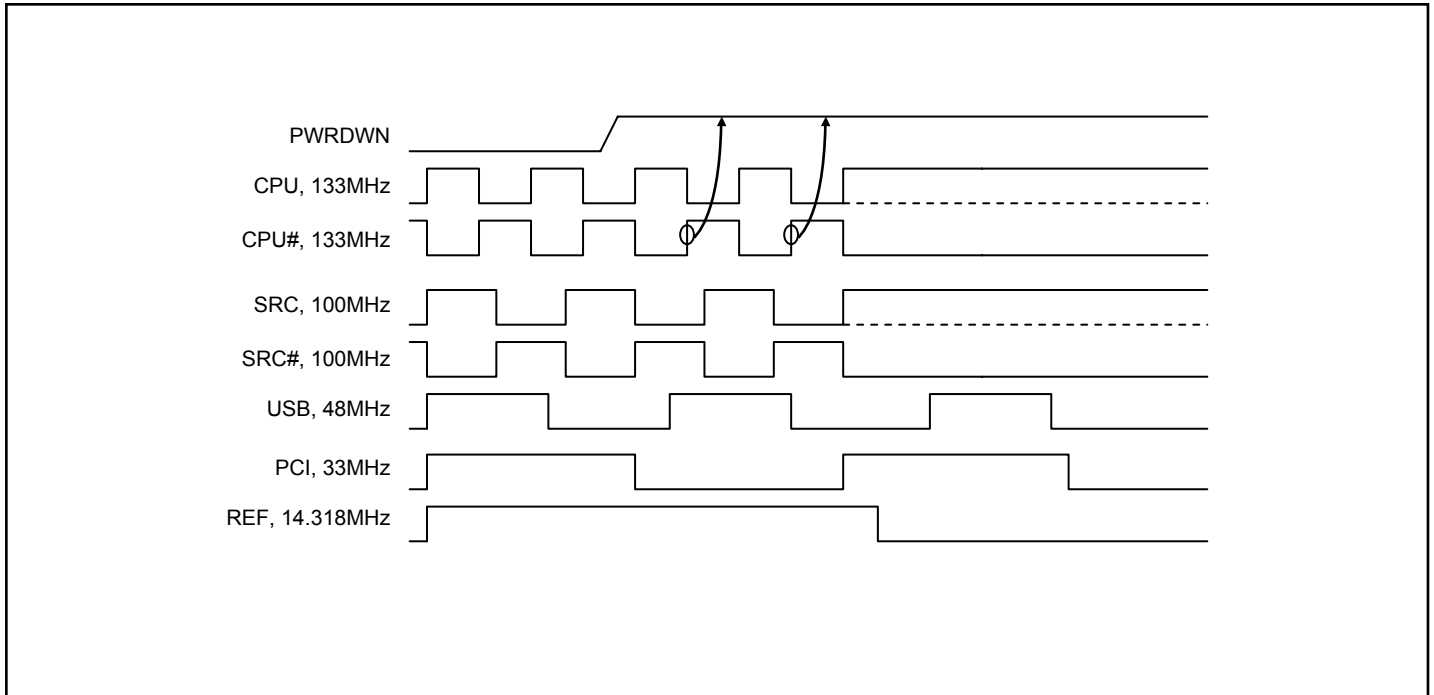
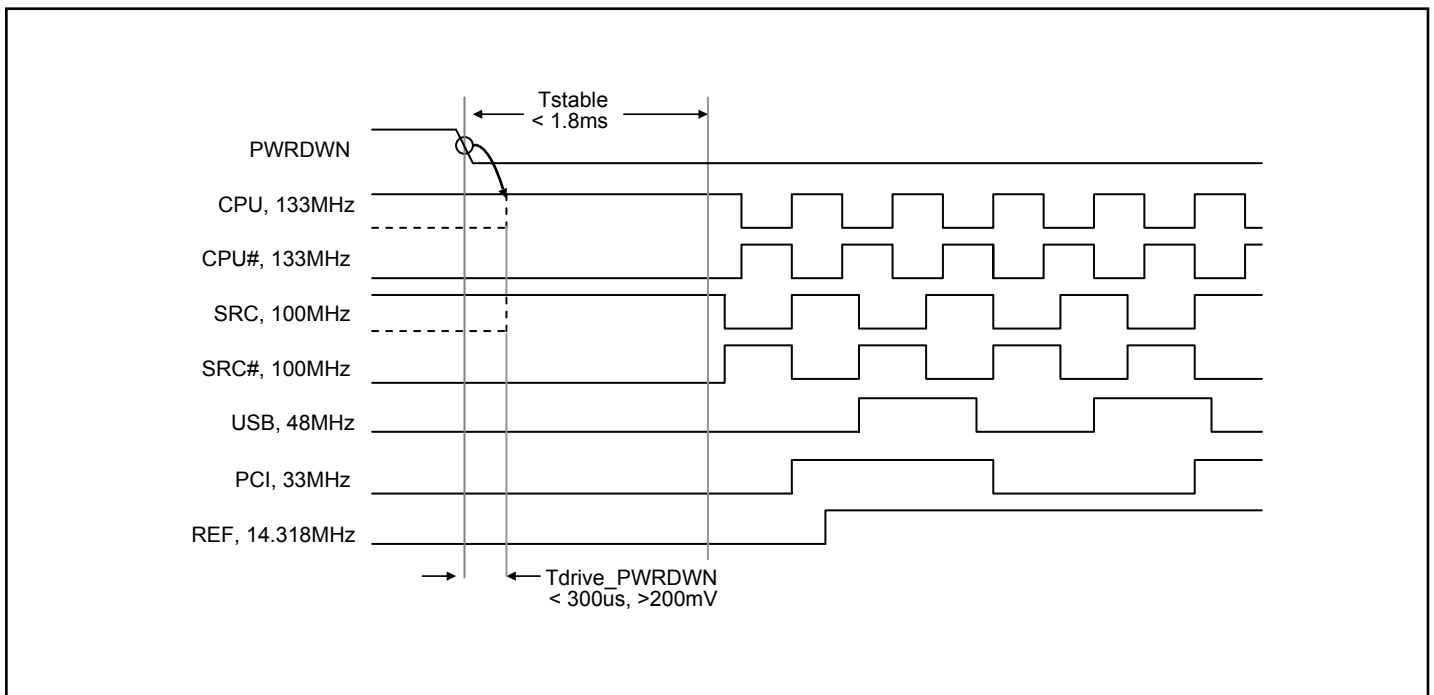

**Power Down (PWRDWN assertion)**

**Figure 1. Power down sequence**
**Power Down (PWRDWN De-assertion)**

**Figure 2. Power down de-assert sequence**

### Tristate Specifications

#### CPU & SRC Tristate clock truth table

Signal	Pwrdown pin	Pwrdown Tristate Bit	Stoppable Outputs	Non-stop Outputs
CPU[0:3], SRC[0:4],	0	X	Running	Running
	1	0	Driven @ Iref x 2	Driven @ Iref x 2
	1	1	Tristate	Tristate

### Spread Spectrum Specifications

Supports Spread Spectrum clocking and can be enabled and disabled via SMBus control. The maximum Spread Spectrum Modulation is -0.5% down spread with frequency from 30KHz to 33K Hz.

SSC ON	Tperiod		SSC OFF	Tperiod		Unit
	Min	Max		Min	Max	
CPU @ 399.000MHz	2.4993	2.5133	CPU @ 400.000MHz	2.4993	2.5008	ns
CPU @ 332.500MHz	2.9991	3.0160	CPU @ 333.333MHz	2.9991	3.0009	
CPU @ 266.000MHz	3.7489	3.7700	CPU @ 266.666MHz	3.7489	3.7511	
CPU @ 199.500MHz	4.9985	5.0266	CPU @ 200.000MHz	4.9985	5.0015	
CPU @ 166.250MHz	5.9982	6.0320	CPU @ 166.666MHz	5.9982	6.0018	
CPU @ 133.000MHz	7.4978	7.5400	CPU @ 133.333MHz	7.4978	7.5023	
CPU @ 99.750MHz	9.9970	10.0533	CPU @ 100.000MHz	9.9970	10.0030	
SRC @ 99.750MHz	9.9970	10.0533	SRC @ 100.000MHz	9.9970	10.0030	
PCIF / PCI @ 33.250MHz	29.9910	30.1598	PCIF / PCI @ 33.333MHz	29.9910	30.0090	

### Crystal Recommendations

Frequency	Cut	Loading	Load Cap	Drive Max.	Shunt Cap Max.	Motional Cap Max.	Tolerance Max.	Stability Max.	Aging Max.
14.31818 MHz	AT	Parallel	20pF	0.1mW	5pF	0.016pF	50ppm	50ppm	5ppm

#### Notes:

- External trim capacitors (Ce) are required by using this formula  $C_e = 2 * C_L - (C_s + C_i)$ . Typical Ce = 33pF when Crystal Load = 20pF, Trace capacitance (Cs) = 2.8pF and XTAL pins capacitance = 4.5pF.

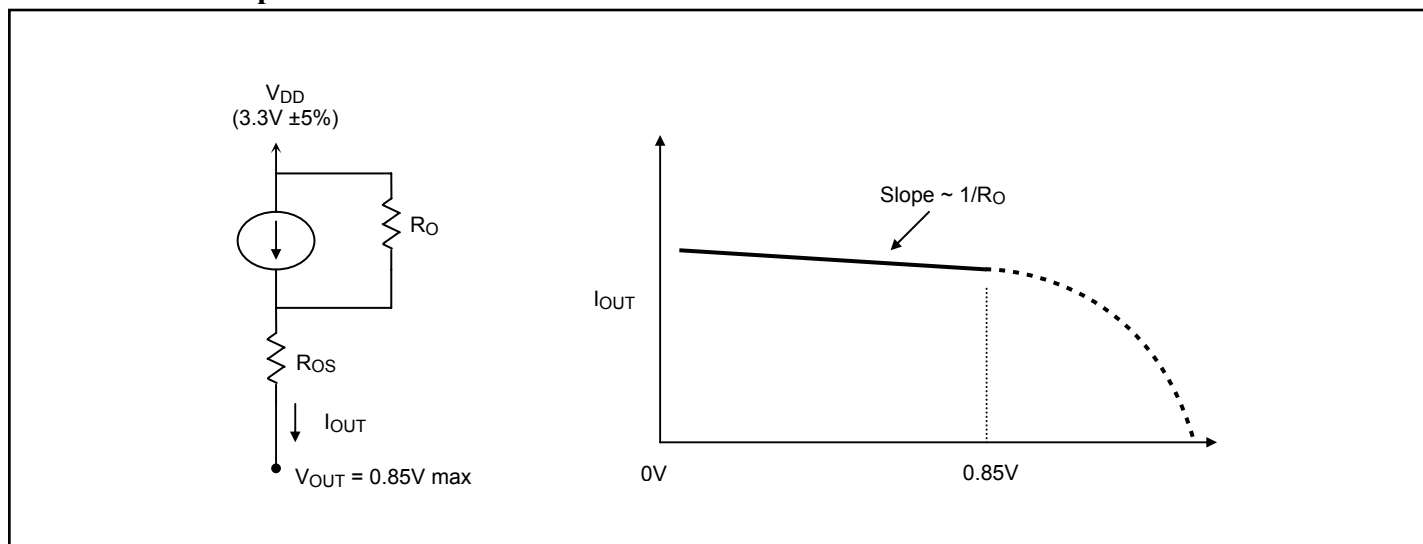
**Current-mode output buffer characteristics of CPU and SRC**

**Figure 3. Simplified diagram of current-mode output buffer**
**Host Clock Buffer characteristics**

Symbol	Minimum	Maximum
$R_O$	3000 $\Omega$	N/A
$R_{OS}$	unspecified	unspecified
$V_{OUT}$	N/A	850mV

**Current Accuracy**

Symbol	Conditions	Configuration	Load	Min.	Max.
$I_{OUT}$	$V_{DD} = 3.30 \pm 5\%$	$R_{REF} = 475\Omega$ 1% $I_{REF} = 2.32\text{mA}$	Nominal test load for given configuration	-12% $I_{NOMINAL}$	+12% $I_{NOMINAL}$

**Note:**

- $I_{NOMINAL}$  refers to the expected current based on the configuration of the device.

**Host Clock Output Current**

Board Target Trace/Term Z	Reference R, $I_{REF} = V_{DD}/(3xRr)$	Output Current	$V_{OH} @ Z$
100 $\Omega$ (100 $\Omega$ differential $\approx$ 8% coupling ratio)	$R_{REF} = 475\Omega$ 1%, $I_{REF} = 2.32\text{mA}$	$I_{OH} = 6 \times I_{REF}$	0.7V @ 50

**Absolute Maximum Ratings** (Over operating free-air temperature range)

Symbol	Parameters	Min.	Max.	Units
V <sub>DD_A</sub>	3.3V Core Supply Voltage	-0.5	4.6	V
V <sub>DD</sub>	3.3V I/O Supply Voltage	-0.5	4.6	
V <sub>IH</sub>	Input High Voltage		4.6	
V <sub>IL</sub>	Input Low Voltage	-0.5		
T <sub>s</sub>	Storage Temperature	-65	150	°C
V <sub>ESD</sub>	ESD Protection	2000		V

**Note:**

1. Stress beyond those listed under “Absolute Maximum Ratings” may cause permanent damage to the device.

**DC Electrical Characteristics** (V<sub>DD</sub> = 3.3±5%, V<sub>DD\_A</sub> = 3.3±5%)

Symbol	Parameters	Condition	Min.	Max.	Units	
V <sub>DD_A</sub>	3.3V Core Supply Voltage		3.135	3.465	V	
V <sub>DD</sub>	3.3V I/O Supply Voltage		3.135	3.465		
V <sub>IH</sub>	3.3V Input High Voltage	V <sub>DD</sub>	2.0	V <sub>DD</sub> + 0.3		
V <sub>IL</sub>	3.3V Input Low Voltage		V <sub>SS</sub> - 0.3	0.8		
I <sub>IK</sub>	Input Leakage Current	0 < V <sub>IN</sub> < V <sub>DD</sub>	-5	+5	µA	
V <sub>IH_FS</sub>	3.3V Input High Voltage		0.7	V <sub>DD</sub> + 0.3	V	
V <sub>IL_FS</sub>	3.3V Input Low Voltage		V <sub>SS</sub> - 0.3	0.35		
V <sub>OH</sub>	3.3V Output High Voltage	I <sub>OH</sub> = -1mA	2.4		V	
V <sub>OL</sub>	3.3V Output Low Voltage	I <sub>OL</sub> = 1mA		0.4		
I <sub>OH</sub>	Output High Current	CPU, SRC: I <sub>OH</sub> = 6 x I <sub>ref</sub> , I <sub>ref</sub> = 2.32mA	12.2	15.6	mA	
			USB	V <sub>OH</sub> = 1.0V		-29
		V <sub>OH</sub> = 3.135V				-23
		REF, PCI	V <sub>OH</sub> = 1.0V	-33		
V <sub>OH</sub> = 3.135V			-33			
I <sub>OL</sub>	Output Low Current	USB	V <sub>OL</sub> = 1.95V	29		
			V <sub>OL</sub> = 0.4V		27	
		REF, PCI	V <sub>OL</sub> = 1.95V	30		
			V <sub>OL</sub> = 0.4V		38	
C <sub>in</sub>	Input Pin Capacitance		3	5	pF	
C <sub>xtal</sub>	Xtal Pin Capacitance		3	6		
C <sub>out</sub>	Output Pin Capacitance			6		
L <sub>pin</sub>	Pin Inductance			7	nH	
I <sub>DD</sub>	Power Supply Current	V <sub>DD</sub> = 3.465V, F <sub>CPU</sub> = 400MHz		500	mA	
I <sub>SS</sub>	Power Down Current	Driven outputs		85		
I <sub>SS</sub>	Power Down Current	Tristate outputs		12		
T <sub>a</sub>	Ambient Temperature		0	70	°C	

**AC Switching Characteristics** ( $V_{DD} = 3.3 \pm 5\%$ ,  $V_{DD\_A} = 3.3 \pm 5\%$ )

Symbol	Outputs	Parameters	Min	Max.	Units	Notes
$T_{rise} / T_{fall}$	CPU, SRC	Rise and Fall Time (measured between 0.175V to 0.525V)	175	700	ps	3, 4
$T_{rise} / T_{fall}$	PCI/PCIF, REF	Rise/Fall Edge Rate (measured between 0.8V to 2.0V)	1.0	4.0	V/ns	6
$T_{rise} / T_{fall}$	USB	Rise/Fall Edge Rate (measured between 0.8V to 2.0V)	1.0	2.0		6
$\Delta T_{rise} / \Delta T_{fall}$	CPU, SRC	Rise and Fall Time Variation		125	ps	3, 4
$T_{skew}$	CPU	CPU – CPU Skew		100	ps	3, 5
$T_{skew}$	SRC	SRC – SRC Skew		250		3, 5
$T_{skew}$	PCI/PCIF, REF	PCI – PCI Skew / REF - REF Skew (measured at 1.5V)		500		6
$T_{jitter}$	CPU	Cycle – Cycle Jitter		85		3, 5
$T_{jitter}$	SRC	Cycle – Cycle Jitter		125		3, 5
$T_{jitter}$	PCI/PCIF	Cycle – Cycle Jitter (measured at 1.5V)		500	6	
$T_{jitter}$	USB	Cycle – Cycle Jitter (measured at 1.5V)		350	6	
$T_{jitter}$	REF	Cycle – Cycle Jitter (measured at 1.5V)		1000	6	
$V_{HIGH}$	CPU, SRC	Voltage High including overshoot	660	1150	mV	3, 4
$V_{LOW}$	CPU, SRC	Voltage Low including undershoot	-300			3, 4
$V_{CROSS}$	CPU, SRC	Absolute crossing point voltages	250	550		3, 4
$\Delta V_{CROSS}$	CPU, SRC	Total Variation of Vcross over all edges		140		3, 4
$T_{DC}$	CPU, SRC	Duty Cycle	45	55	%	3, 5
$T_{DC}$	REF, USB, PCI/PCIF	Duty Cycle (measured at 1.5V)	45	55		6
$T_{stable}$		All clock stabilization from power-up		<1.8	ms	Fig 2
$T_{drive} PwrDwn$		Differential output enable after PwrDwn de-assertion		300	$\mu$ s	Fig 2
$T_{rise} / T_{fall} PwrDwn$		PwrDwn rise and fall time		5.0	ns	

**Notes:**

3. Test configuration is  $R_s = 33.2\Omega$ ,  $R_p = 49.9\Omega$ , and 2pF.
4. Measurement taken from Single Ended waveform.
5. Measurement taken from Differential waveform.
6. Two Loads for PCI/PCIF and USB. Three loads for REF.  $R_S=12\Omega$ 5%, Max 20" into 5pF load with 60 $\Omega$  impedance.

Configuration test load board termination

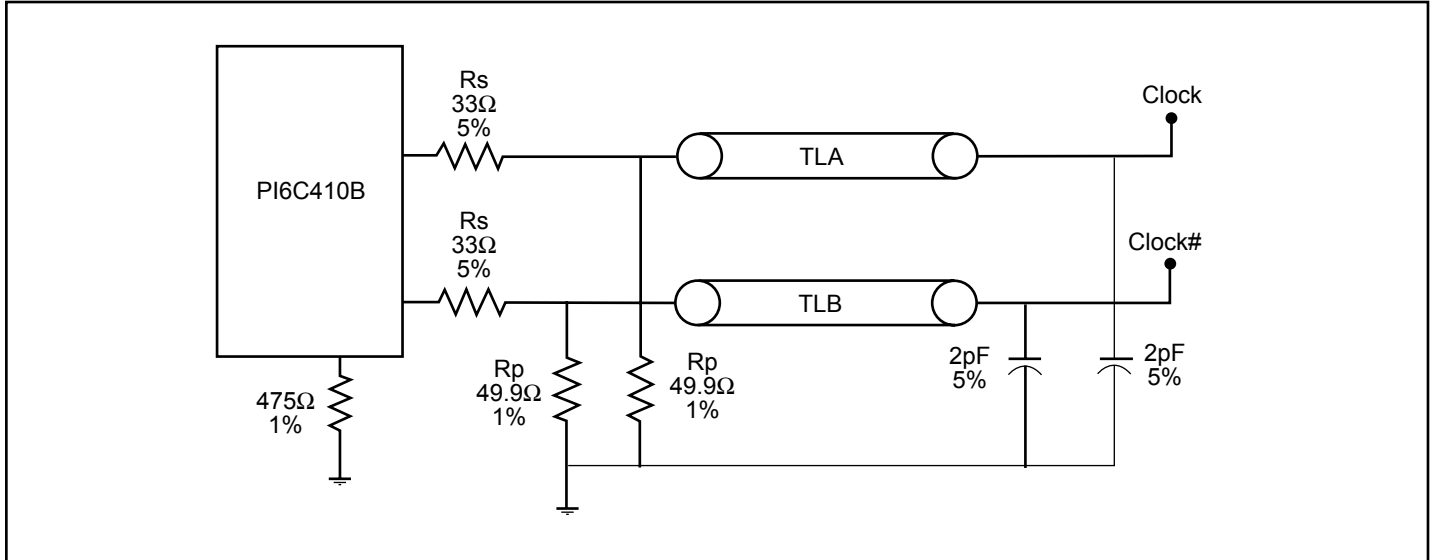
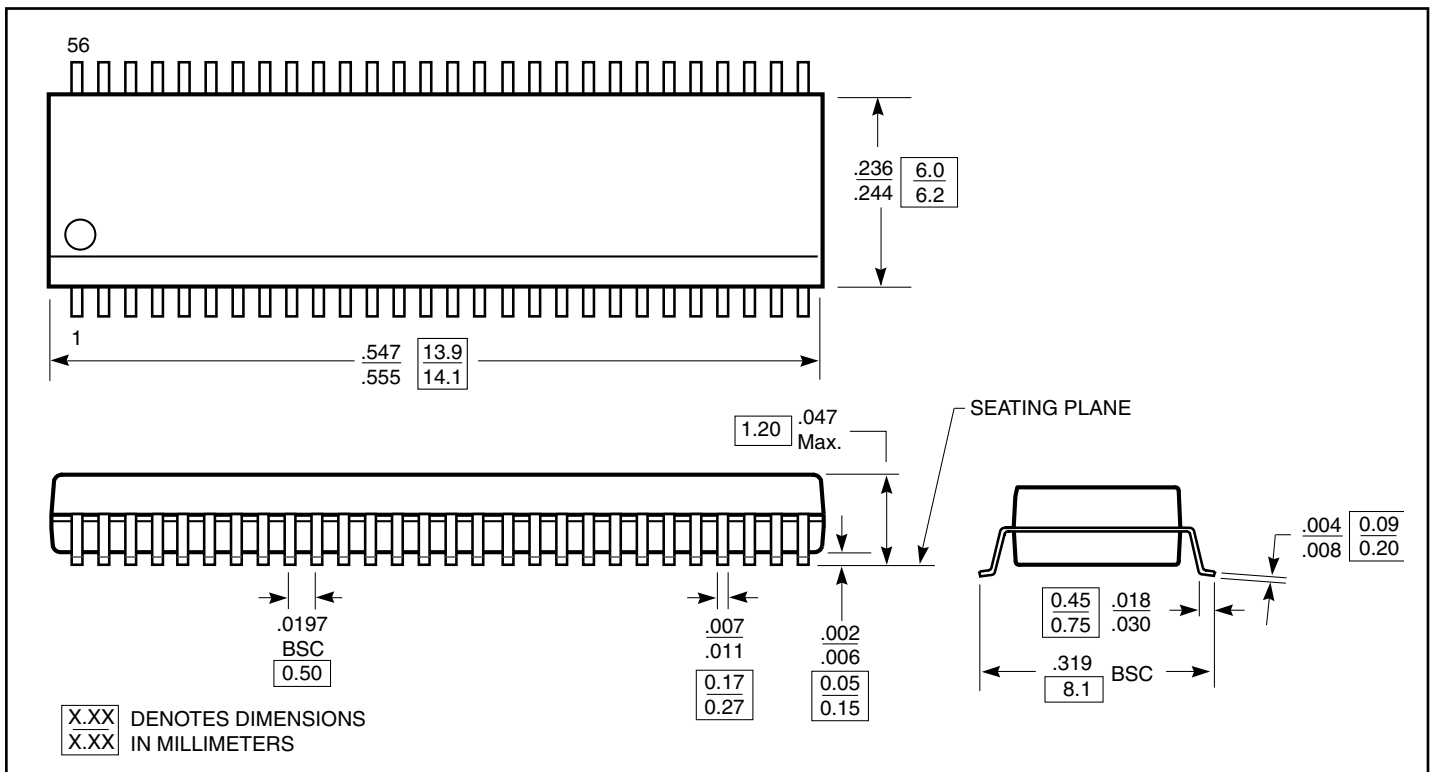

Figure 4. Configuration test load board termination

Note:

1. Maximum 10" trace length for CPU outputs at 200 MHz. Maximum 16" trace length for SRC outputs at 100 MHz.

Packaging Mechanical: 56-Pin, 240-mil wide TSSOP (A)



**Packaging Mechanical: 56-Pin, 300-mil wide SSOP (V)**

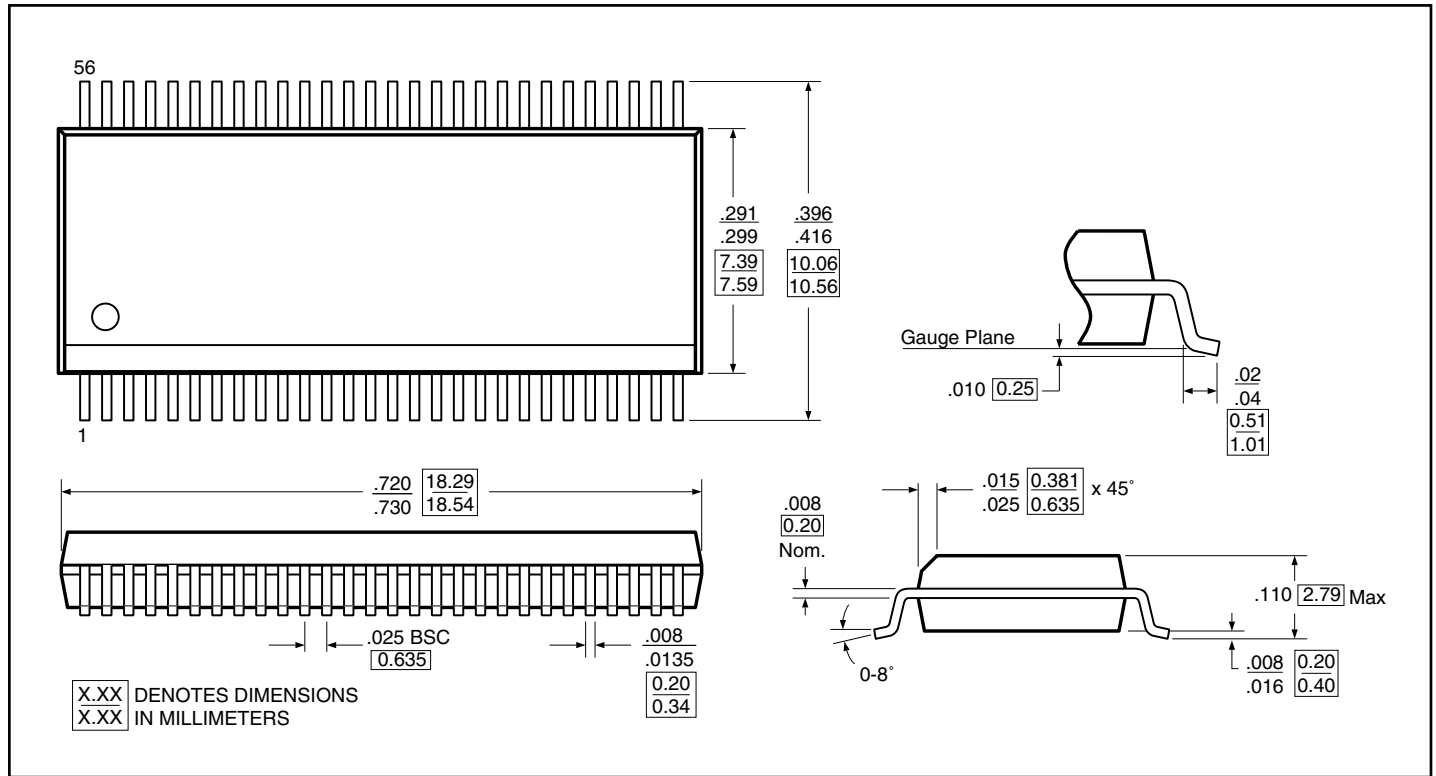

**Ordering Information(1,2,3)**

Ordering Code	Package Code	Package Description
PI6C410BAE	A	Pb-free & Green, 56-pin TSSOP
PI6C410BVE	V	Pb-free & Green, 56-pin SSOP

**Notes:**

1. Thermal characteristics can be found on the company web site at [www.pericom.com/packaging/](http://www.pericom.com/packaging/)
2. Number of transistors = TBD
3. E = Pb-free and Green