

# Agilent Dual Directional Coupler 778D 100 to 2000 MHz

## Data Sheet



- **Multi-octave frequency range: 100 to 2000 MHz**
- **High directivity: 36 dB to 1 GHz, 32 dB to 2 GHz**
- **Reflection coefficient measurement: Over 4 octaves with 1 coupler**

### **Broadband 20 dB Dual Directional Coupler**

---

This dual directional 20 dB coupler has a frequency range extending over 4 octaves from 100 MHz to 2 GHz. The multi-octave capability makes measurements easier—setup and calibration time are reduced, since normally several couplers are required over this frequency band. The coupling factor increases about 6 dB per octave below 100 MHz; thus, usefulness below this frequency is restricted only by the amount of signal source power and/or the sensitivity of the RF detector connected to the coupler. Figure 1 shows typical coupling and directivity characteristics of the 778D.

### **Simultaneous Reflection and Transmission Measurements**

---

The 778D is ideal for measuring the reflection and transmission characteristics of a device from 100 MHz to 2000 MHz. Figure 2 shows a test configuration in which a 778D dual directional coupler is used to separate and isolate the incident, reflected, and transmitted signals in a swept-frequency measurement. These signals are detected and their ratio displayed on a CRT. This coupler is an ideal companion for the Agilent 8755 frequency response test set, a detection and display system operating from 15 MHz to 18 GHz.



The high directivity and close tracking of the auxiliary arms of this coupler make it particularly useful for this type of broadband measurement. The high directivity insures accurate measurements by a true separation of the forward and reflected signals. Close tracking of signal variation from the auxiliary arms gives a flat frequency response that makes display readings easy to interpret.

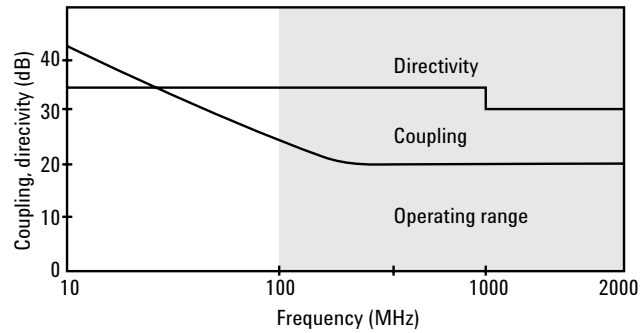

Figure 1. Coupling and directivity characteristics of the 778D coupler.

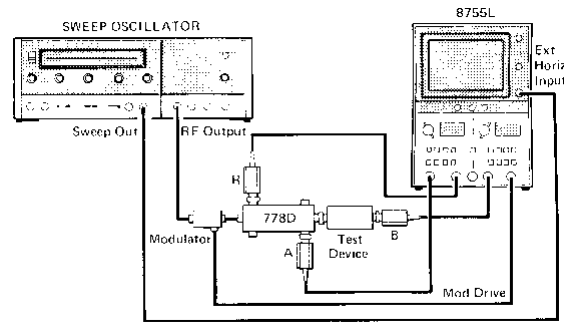

Figure 2. Setup diagram for simultaneous measurements of insertion and return loss.

Maximum amplitude errors in a reflection measuring system are shown in the following table

Frequency range	Maximum magnitude error $\Delta\Gamma_L$	
	Swept frequency	Fixed frequency
0.1 to 1GHz	$\pm (0.015 + 0.02  \Gamma_L  + 0.05  \Gamma_L ^2)$	$\pm (0.015 + 0.05  \Gamma_L ^2)$
1 to 2 GHz	$\pm (0.025 + 0.02  \Gamma_L  + 0.05  \Gamma_L ^2)$	$\pm (0.025 + 0.05  \Gamma_L ^2)$

Maximum phase error =  $\pm \sin^{-1}(\Delta\Gamma_L/\Gamma_L)$   
 $|\Gamma_L|$  = reflection coefficient of unknown

Error components include a fixed term due to coupler directivity, and several  $\Gamma_L$ -dependent terms relating to source match and reference setting (detection errors are not included). These errors apply over broad swept-frequency bands. Somewhat improved accuracy can be achieved by simple recalibration at the frequency of interest.

## **Impedance Measurements**

---

The 778D is also well suited for measurements of impedance when used with the Agilent 8405A vector voltmeter. The technique is described in *Application Note 77-3, Measurement of Complex Impedance*, available at your nearest Agilent sales office. Again, a reflectometry technique is used. With the vector voltmeter, however, both magnitude and phase angle of the reflection coefficient can be measured. This setup is shown in Figure 3.

Data can be read from the two meters of the vector voltmeter and transferred directly to a Smith Chart to provide impedance of such devices as antennas or other passive components. In addition, with an appropriate bias supply, active components, such as transistors, can also be quickly measured and characterized with this setup. The 778D is well-suited for these types of measurements since both the phase and the magnitude variation between the two coupling arms have been closely controlled in the design of the coupler.

## **System Monitoring**

---

Because of the high power capability of the dual directional coupler, it can be permanently installed in coaxial systems to monitor the power traveling in both directions simultaneously. This enables a system to be continually monitored to indicate whether the system is in need of adjustment or maintenance due to excessive standing-wave ratios on the transmission lines.

## **Choice of Output Connectors**

---

To achieve its broad frequency coverage, the 778D's directivity is optimized for mainline energy flowing in one direction. Thus, the test device or system should be connected where the 778D is labeled TEST PORT. To accommodate test devices with type-N or APC-7<sup>1</sup> connectors, a choice of connectors is available on the TEST PORT; see the options outlined in the specifications below.

The APC-7 precision sexless connector is recommended on the output, since the coupler can be conveniently converted to other types of connectors by use of an adapter. Adapters are available to OSM, TNC, GR900, and others, so that the coupler becomes a versatile device for making measurements on many different types of connector configurations. The Amphenol, APC-7 is a sexless connector with very low SWR. This precision connector makes possible the construction of adapters with the lowest possible SWR.

The type-N connectors are stainless steel for long wear and are compatible with connectors whose dimensions conform to MIL-C-39012, or MIL-C-71.

---

1. Amphenol RF Division, Danbury, Conn.

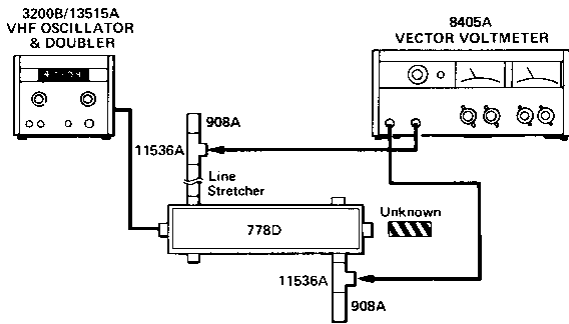
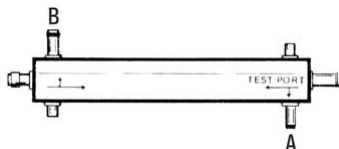

Figure 3. Setup of impedance measurement of coaxial devices from ~10 to 1000 MHz.

## Specifications

**Frequency range** 100 MHz to 2000 MHz (usable below 100 MHz)



Directivity	Auxiliary arm	0.1 to 1 GHz	1 to 2 GHz
	A	36 dB	32 dB
B	30 dB	30 dB	

**Coupling factor** 20 dB nominal  $\pm 1$  dB cyclic variation with frequency (coupling  $\sim 23$  dB at 100 MHz. 6 dB rolloff per octave below 100 MHz).

**Tracking** Auxiliary outputs typically track within 0.7 dB. Phase tracking typically  $4^\circ$ .

**SWR** Primary line: 1.1; auxiliary arms: 1.1.

**Maximum power** 50 W average; 500 W peak.

**Connectors** Choice of mainline connectors (see options); auxiliary arms have type-N female connectors. All type-N connectors stainless steel, compatible with MIL-C-39012 and MIL-C-71.

**Dimensions** 16.75 inches long, 4.375 inches high, 1.189 inches wide (425 x 111 x 30 mm).

**Weight** Net, 3.75 lb (1,5 kg). Shipping, 5 lb (2,3 kg).

### Accessories available

Adapters	Part number
APC-7 to OSM <sup>®</sup> male	11533A
APC-7 to OSM female	11534A
APC-7 to type-N male	11525A
APC-7 to type-N female	11524A

(Adapters from APC-7 to TNC, GR-900, GR-874 as well as the above are available from Amphenol RF Division, Danbury, Conn.)

778D	(type-N female output, type-N male input connectors)
Option 11	(APC-7 output, type-N female input connectors)
Option 12	(type-N male output, type-N female input connectors)

### Agilent Technologies' Test and Measurement Support, Services, and Assistance

Agilent Technologies aims to maximize the value you receive, while minimizing your risk and problems. We strive to ensure that you get the test and measurement capabilities you paid for and obtain the support you need. Our extensive support resources and services can help you choose the right Agilent products for your applications and apply them successfully. Every instrument and system we sell has a global warranty. Support is available for at least five years beyond the production life of the product. Two concepts underlie Agilent's overall support policy: "Our Promise" and "Your Advantage."

#### Our Promise

Our Promise means your Agilent test and measurement equipment will meet its advertised performance and functionality. When you are choosing new equipment, we will help you with product information, including realistic performance specifications and practical recommendations from experienced test engineers. When you receive your new Agilent equipment, we can help verify that it works properly and help with initial product operation.

#### Your Advantage

Your Advantage means that Agilent offers a wide range of additional expert test and measurement services, which you can purchase according to your unique technical and business needs. Solve problems efficiently and gain a competitive edge by contracting with us for calibration, extra-cost upgrades, out-of-warranty repairs, and onsite education and training, as well as design, system integration, project management, and other professional engineering services. Experienced Agilent engineers and technicians worldwide can help you maximize your productivity, optimize the return on investment of your Agilent instruments and systems, and obtain dependable measurement accuracy for the life of those products.

#### Agilent T&M Software and Connectivity

Agilent's Test and Measurement software and connectivity products, solutions and developer network allows you to take time out of connecting your instruments to your computer with tools based on PC standards, so you can focus on your tasks, not on your connections. Visit [www.agilent.com/find/connectivity](http://www.agilent.com/find/connectivity) for more information.

**For more information on Agilent Technologies' products, applications or services, please contact your local Agilent office. The complete list is available at:**

#### Phone or Fax

**United States:**  
(tel) 800 829 4444  
(fax) 800 829 4433  
**Canada:**  
(tel) 877 894 4414  
(fax) 800 746 4866  
**China:**  
(tel) 800 810 0189  
(fax) 800 820 2816  
**Europe:**  
(tel) 31 20 547 2111  
**Japan:**  
(tel) (81) 426 56 7832  
(fax) (81) 426 56 7840

**Korea:**  
(tel) (080) 769 0800  
(fax) (080)769 0900  
**Latin America:**  
(tel) (305) 269 7500  
**Taiwan:**  
(tel) 0800 047 866  
(fax) 0800 286 331  
**Other Asia Pacific Countries:**  
(tel) (65) 6375 8100  
(fax) (65) 6755 0042  
Email: [tm\\_ap@agilent.com](mailto:tm_ap@agilent.com)

#### [www.agilent.com/find/contactus](http://www.agilent.com/find/contactus)

Product specifications and descriptions in this document subject to change without notice.

© Agilent Technologies, Inc. 2004  
Printed in USA, September 13, 2004  
5952-8133



### Agilent Email Updates

[www.agilent.com/find/emailupdates](http://www.agilent.com/find/emailupdates)  
Get the latest information on the products and applications you select.



**Agilent Technologies**