



# QUICKSWITCH® PRODUCTS

## 2.5V / 3.3V 20-BIT 2-PORT, HIGH BANDWIDTH BUS SWITCH

**IDTQS3VH16210**

### FEATURES:

- N channel FET switches with no parasitic diode to Vcc
  - Isolation under power-off conditions
  - No DC path to Vcc or GND
  - 5V tolerant in OFF and ON state
- 5V tolerant I/Os
- Low RON - 4Ω typical
- Flat RON characteristics over operating range
- Rail-to-rail switching 0 - 5V
- Bidirectional dataflow with near-zero delay: no added ground bounce
- Excellent RON matching between channels
- Vcc operation: 2.3V to 3.6V
- High bandwidth - up to 500 MHz
- LVTTTL-compatible control Inputs
- Undershoot Clamp Diodes on all switch and control Inputs
- Low I/O capacitance, 4pF typical
- Available in SSOP and TSSOP packages

### APPLICATIONS:

- Hot-swapping
- 10/100 Base-T, Ethernet LAN switch
- Low distortion analog switch
- Replaces mechanical relay
- ATM 25/155 switching

### DESCRIPTION:

The QS3VH16210 HotSwitch with 20-bit flow-through pin is a high bandwidth bus switch. The QS3VH16210 has very low ON resistance, resulting in under 250ps propagation delay through the switch. The switches are controlled by active low enable ( $\overline{xOE}$ ) controls. The QS3VH16210 is organized as a dual 10-bit, 2-port bus switch with separate,  $\overline{xOE}$  control inputs. In the OFF and ON states, the switches are 5V-tolerant. In the OFF state, the switches offer very high impedance at the terminals.

The combination of near-zero propagation delay, high OFF impedance, and over-voltage tolerance makes the QS3VH16210 ideal for high performance communications applications.

The QS3VH16210 is characterized for operation from -40°C to +85°C.

### FUNCTIONAL BLOCK DIAGRAM

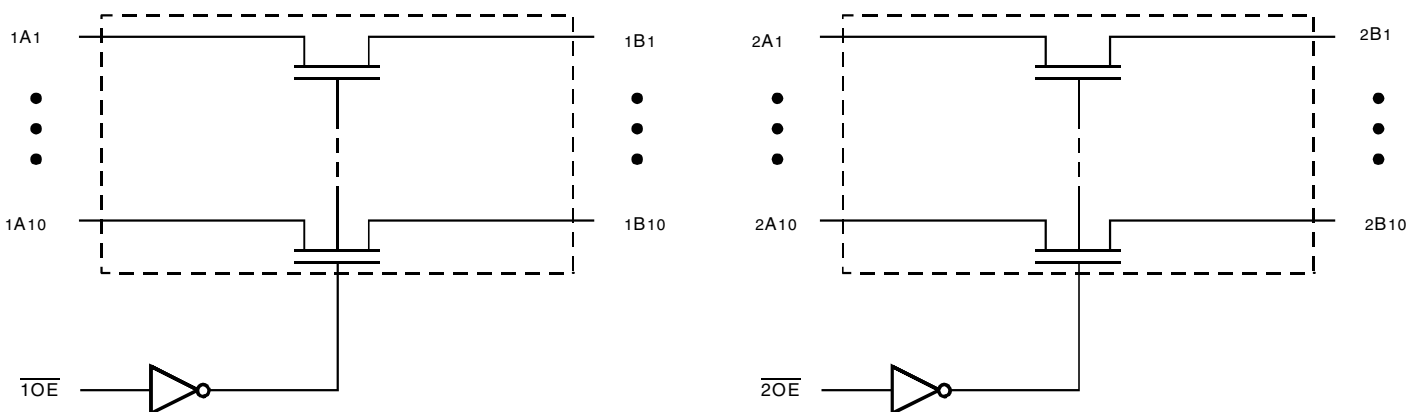

The IDT logo is a registered trademark of Integrated Device Technology, Inc.

## PIN CONFIGURATION

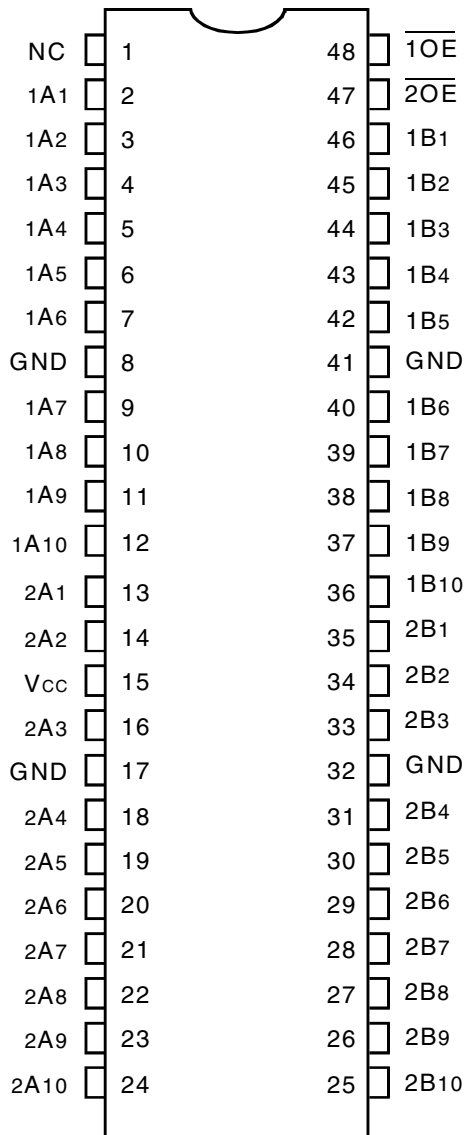

SSOP/ TSSOP  
TOP VIEW

## ABSOLUTE MAXIMUM RATINGS<sup>(1)</sup>

Symbol	Description	Max.	Unit
VTERM <sup>(2)</sup>	Supply Voltage to Ground	-0.5 to 4.6	V
VTERM <sup>(3)</sup>	DC Switch Voltage V <sub>s</sub>	-0.5 to 5.5	V
VTERM <sup>(3)</sup>	DC Input Voltage V <sub>IN</sub>	-0.5 to 5.5	V
V <sub>AC</sub>	AC Input Voltage (pulse width ≤20ns)	-3	V
I <sub>OUT</sub>	DC Output Current (max. current/pin)	120	mA
T <sub>STG</sub>	Storage Temperature	-65 to +150	°C

### NOTES:

- Stresses greater than those listed under ABSOLUTE MAXIMUM RATINGS may cause permanent damage to the device. This is a stress rating only and functional operation of the device at these or any other conditions above those indicated in the operational sections of this specification is not implied. Exposure to absolute maximum rating conditions for extended periods may affect reliability.
- V<sub>CC</sub> terminals.
- All terminals except V<sub>CC</sub>.

## CAPACITANCE (T<sub>A</sub> = +25°C, f = 1MHz, V<sub>IN</sub> = 0V, V<sub>OUT</sub> = 0V)

Symbol	Parameter <sup>(1)</sup>	Typ.	Max.	Unit
C <sub>IN</sub>	Control Inputs	3	5	pF
C <sub>I/O</sub>	Quickswitch Channels (Switch OFF)	4	6	pF
C <sub>I/O</sub>	Quickswitch Channels (Switch ON)	8	12	pF

### NOTE:

- This parameter is guaranteed but not production tested.

## PIN DESCRIPTION

Pin Names	Description
$\overline{xOE}$	Bus Enables (Active LOW)
1A1 - 1A10, 2A1 - 2A10	Bus A
1B1 - 1B10, 2B1 - 2B10	Bus B

## FUNCTION TABLE (EACH 10-BIT BUS SWITCH) <sup>(1)</sup>

Control Input $\overline{xOE}$	Function
L	A port = B port
H	Disconnect

### NOTE:

- H = HIGH Voltage Level  
L = LOW Voltage Level

## DC ELECTRICAL CHARACTERISTICS OVER OPERATING RANGE

Following Conditions Apply Unless Otherwise Specified:

Industrial:  $T_A = -40^{\circ}\text{C}$  to  $+85^{\circ}\text{C}$ ,  $V_{CC} = 3.3\text{V} \pm 0.3\text{V}$

Symbol	Parameter	Test Conditions	Min.	Typ. <sup>(1)</sup>	Max.	Unit		
$V_{IH}$	Input HIGH Voltage	Guaranteed Logic HIGH for Control Inputs	$V_{CC} = 2.3\text{V to }2.7\text{V}$	1.7	—	—	V	
			$V_{CC} = 2.7\text{V to }3.6\text{V}$	2	—	—		
$V_{IL}$	Input LOW Voltage	Guaranteed Logic HIGH for Control Inputs	$V_{CC} = 2.3\text{V to }2.7\text{V}$	—	—	0.7	V	
			$V_{CC} = 2.7\text{V to }3.6\text{V}$	—	—	0.8		
$I_{IN}$	Input Leakage Current (Control Inputs)	$0\text{V} \leq V_{IN} \leq V_{CC}$	—	—	$\pm 1$	$\mu\text{A}$		
$I_{OZ}$	Off-State Current (Hi-Z)	$0\text{V} \leq V_{OUT} \leq 5\text{V}$ , Switches OFF	—	—	$\pm 1$	$\mu\text{A}$		
$I_{OFF}$	Data Input/Output Power Off Leakage	$V_{IN}$ or $V_{OUT}$ 0V to 5V, $V_{CC} = 0\text{V}$	—	—	$\pm 1$	$\mu\text{A}$		
$R_{ON}$	Switch ON Resistance	$V_{CC} = 2.3\text{V}$ (Typ. at $V_{CC} = 2.5\text{V}$ )	$V_{IN} = 0\text{V}$	$I_{ON} = 30\text{mA}$	—	6	8	$\Omega$
			$V_{IN} = 1.7\text{V}$	$I_{ON} = 15\text{mA}$	—	7	9	
		$V_{CC} = 3\text{V}$	$V_{IN} = 0\text{V}$	$I_{ON} = 30\text{mA}$	—	4	6	
			$V_{IN} = 2.4\text{V}$	$I_{ON} = 15\text{mA}$	—	5	8	

**NOTE:**

1. Typical values are at  $V_{CC} = 3.3\text{V}$  and  $T_A = 25^{\circ}\text{C}$ , unless otherwise noted.

### TYPICAL ON RESISTANCE vs $V_{IN}$ AT $V_{CC} = 3.3\text{V}$

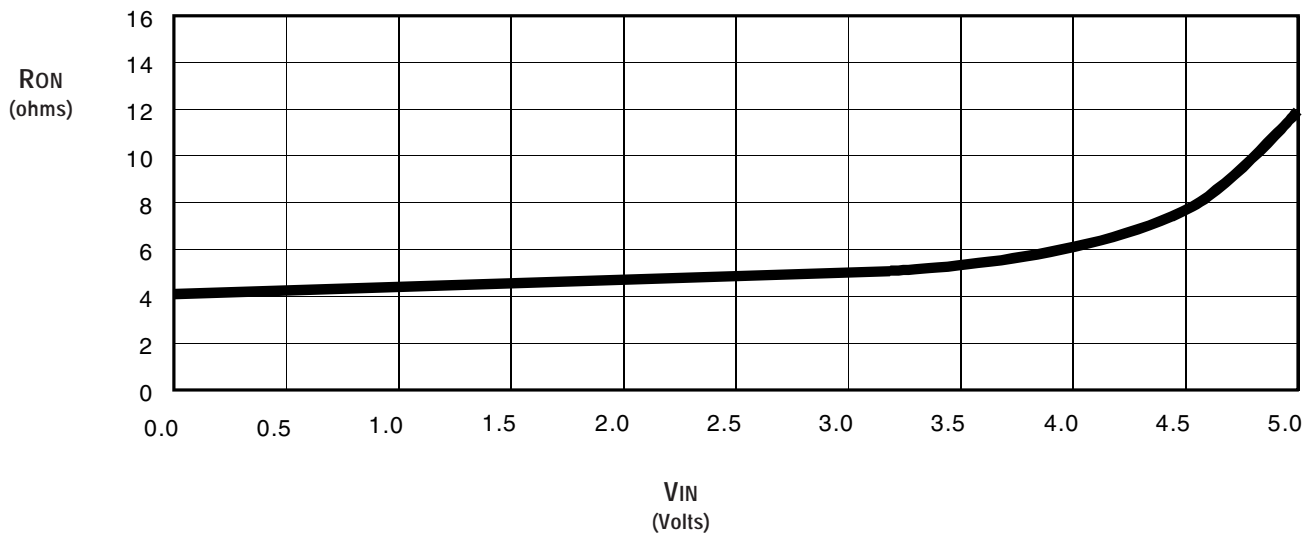

### POWER SUPPLY CHARACTERISTICS

Symbol	Parameter	Test Conditions <sup>(1)</sup>	Min.	Typ.	Max.	Unit
I <sub>CCQ</sub>	Quiescent Power Supply Current	V <sub>CC</sub> = Max., V <sub>IN</sub> = GND or V <sub>CC</sub> , f = 0	—	1.5	3	mA
ΔI <sub>CC</sub>	Power Supply Current <sup>(2,3)</sup> per Input HIGH	V <sub>CC</sub> = Max., V <sub>IN</sub> = 3V, f = 0 per Control Input	—	—	30	μA
I <sub>CCD</sub>	Dynamic Power Supply Current <sup>(4)</sup>	V <sub>CC</sub> = 3.3V, A and B Pins Open, Control Inputs Toggling @ 50% Duty Cycle	See Typical I <sub>CCD</sub> vs Enable Frequency graph below			

**NOTES:**

1. For conditions shown as Min. or Max., use the appropriate values specified under DC Electrical Characteristics.
2. Per input driven at the specified level. A and B pins do not contribute to ΔI<sub>CC</sub>.
3. This parameter is guaranteed but not tested.
4. This parameter represents the current required to switch internal capacitance at the specified frequency. The A and B inputs do not contribute to the Dynamic Power Supply Current. This parameter is guaranteed but not production tested.

### TYPICAL I<sub>CCD</sub> vs ENABLE FREQUENCY CURVE AT V<sub>CC</sub> = 3.3V

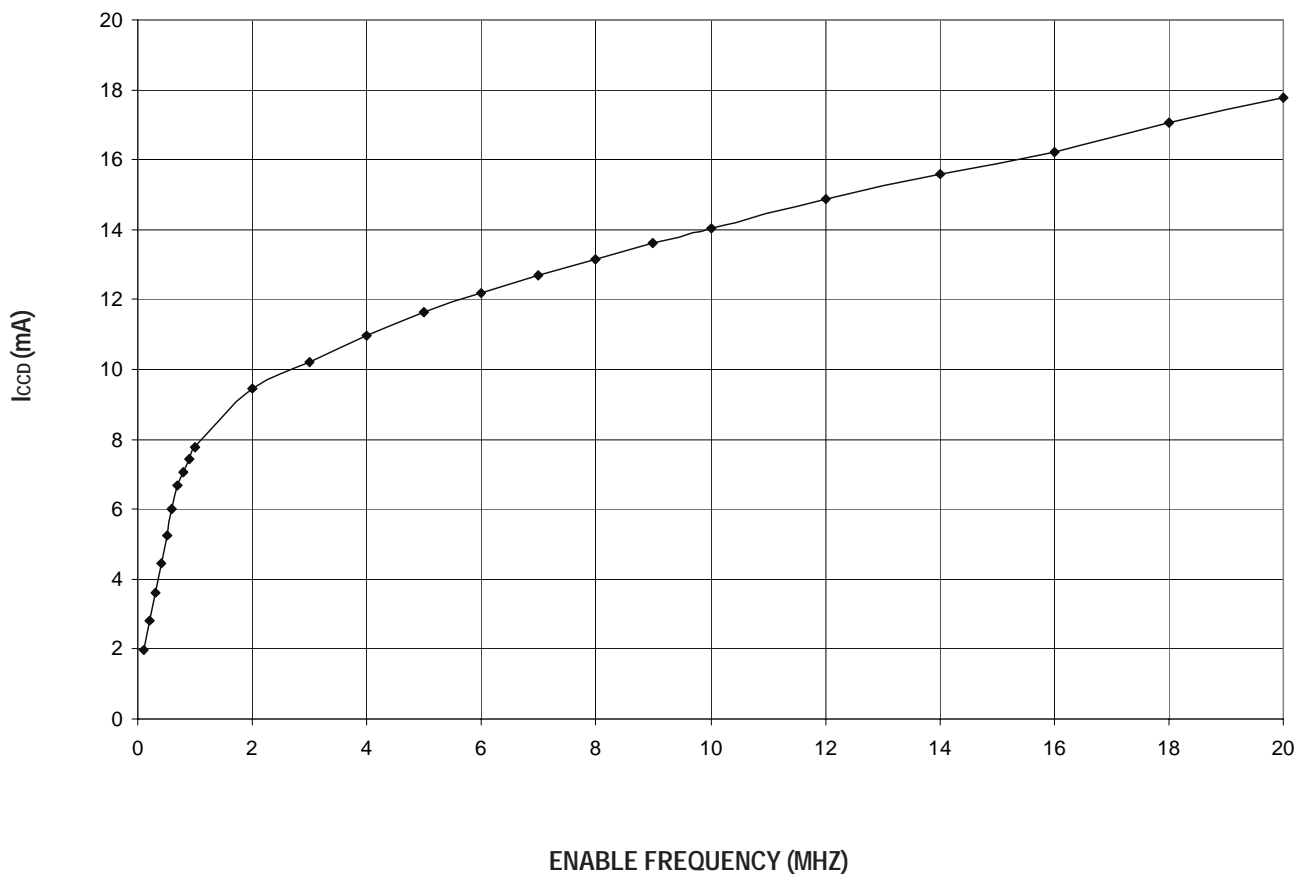

## SWITCHING CHARACTERISTICS OVER OPERATING RANGE

T<sub>A</sub> = -40°C to +85°C

Symbol	Parameter	V <sub>CC</sub> = 2.5 ± 0.2V <sup>(1)</sup>		V <sub>CC</sub> = 3.3 ± 0.3V <sup>(1)</sup>		Unit
		Min. <sup>(4)</sup>	Max.	Min. <sup>(4)</sup>	Max.	
t <sub>PLH</sub> t <sub>PHL</sub>	Data Propagation Delay <sup>(2,3)</sup> A to B or B to A	—	0.2	—	0.2	ns
t <sub>PZH</sub> t <sub>PZL</sub>	Switch Turn-On Delay $\overline{xBE}$ to xA or xB	1.5	9	1.5	9	ns
t <sub>PHZ</sub> t <sub>PLZ</sub>	Switch Turn-Off Delay $\overline{xBE}$ to xA or xB	1.5	8.5	1.5	8.5	ns
$\overline{fxOE}$	Operating Frequency - Enable <sup>(2,5)</sup>	—	7.5	—	20	MHz

### NOTES:

1. See Test Conditions under TEST CIRCUITS AND WAVEFORMS.
2. This parameter is guaranteed but not production tested.
3. The bus switch contributes no propagation delay other than the RC delay of the ON resistance of the switch and the load capacitance. The time constant for the switch alone is of the order of 0.2ns at C<sub>L</sub> = 50pF. Since this time constant is much smaller than the rise and fall times of typical driving signals, it adds very little propagation delay to the system. Propagation delay of the bus switch, when used in a system, is determined by the driving circuit on the driving side of the switch and its interaction with the load on the driven side.
4. Minimums are guaranteed but not production tested.
5. Maximum toggle frequency for  $\overline{fxOE}$  control input (pass voltage > V<sub>CC</sub>, V<sub>IN</sub> = 5V, R<sub>LOAD</sub> > 1MΩ, no C<sub>LOAD</sub>).

SOME APPLICATIONS FOR HOTSWITCH PRODUCTS

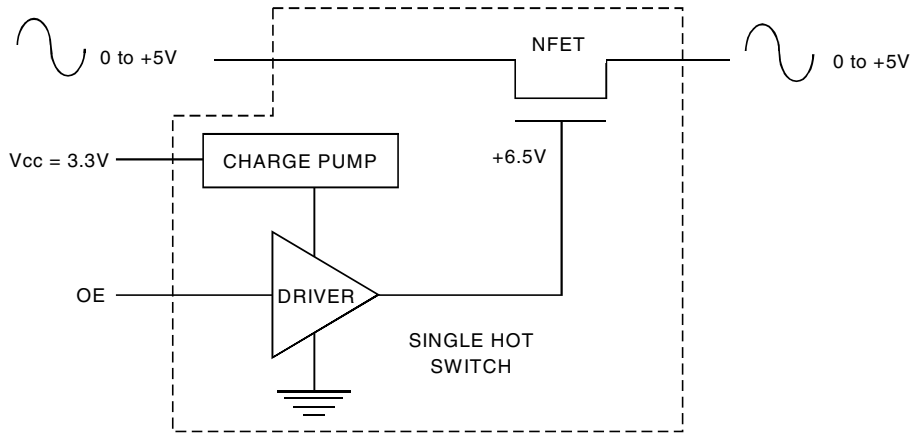

*Rail-to-Rail Switching*

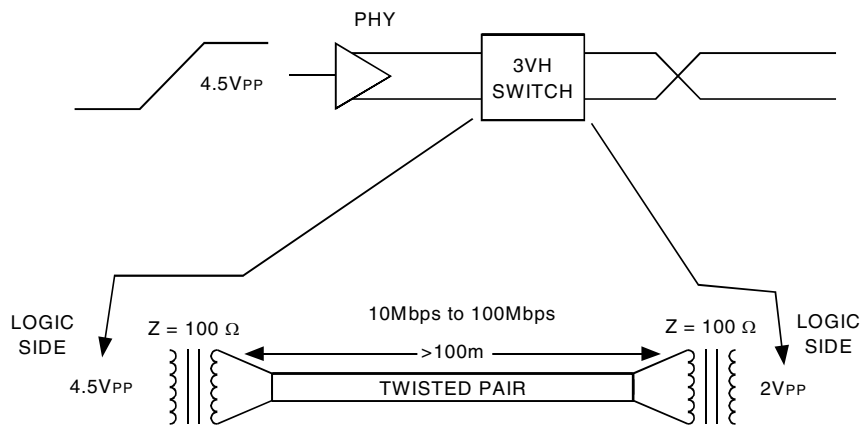

*Fast Ethernet Data Switching (LAN Switch)*

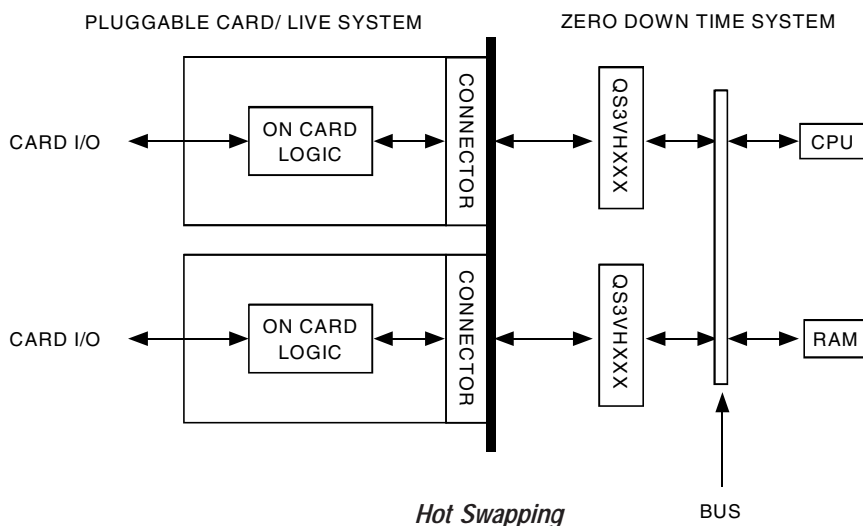

*Hot Swapping*

## TEST CIRCUITS AND WAVEFORMS

### TEST CONDITIONS

Symbol	Vcc <sup>(1)</sup> = 3.3V ± 0.3V	Vcc <sup>(2)</sup> = 2.5V ± 0.2V	Unit
V <sub>LOAD</sub>	6	2 x Vcc	V
V <sub>IH</sub>	3	Vcc	V
V <sub>T</sub>	1.5	Vcc/2	V
V <sub>LZ</sub>	300	150	mV
V <sub>HZ</sub>	300	150	mV
C <sub>L</sub>	50	30	pF

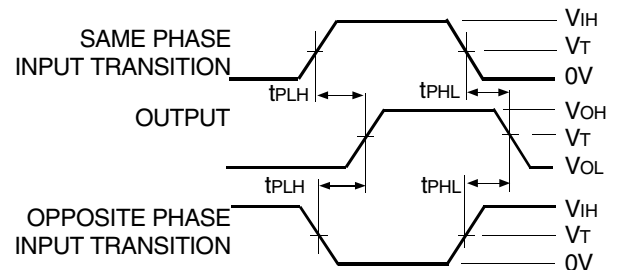

*Propagation Delay*

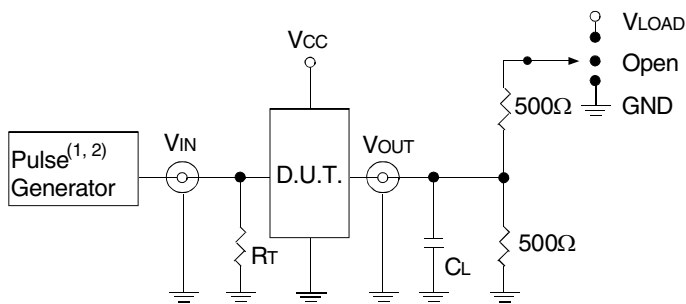

*Test Circuits for All Outputs*

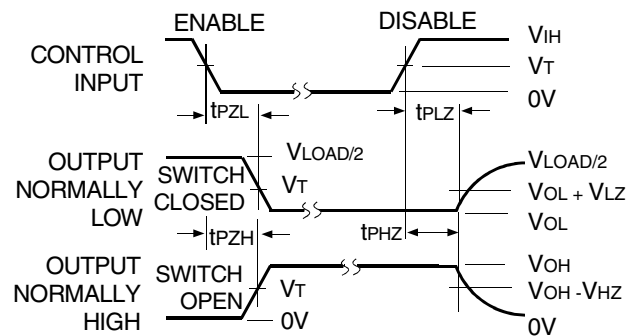

**NOTE:**

1. Diagram shown for input Control Enable-LOW and input Control Disable-HIGH.

*Enable and Disable Times*

**DEFINITIONS:**

C<sub>L</sub> = Load capacitance: includes jig and probe capacitance.  
R<sub>T</sub> = Termination resistance: should be equal to Z<sub>OUT</sub> of the Pulse Generator.

**NOTES:**

1. Pulse Generator for All Pulses: Rate ≤ 1.0MHz; t<sub>r</sub> ≤ 2.5ns; t<sub>r</sub> ≤ 2.5ns.
2. Pulse Generator for All Pulses: Rate ≤ 1.0MHz; t<sub>r</sub> ≤ 2ns; t<sub>r</sub> ≤ 2ns.

### SWITCH POSITION

Test	Switch
t <sub>PLZ</sub> /t <sub>PZL</sub>	V <sub>LOAD</sub>
t <sub>PHZ</sub> /t <sub>PZH</sub>	GND
t <sub>PD</sub>	Open

## ORDERING INFORMATION

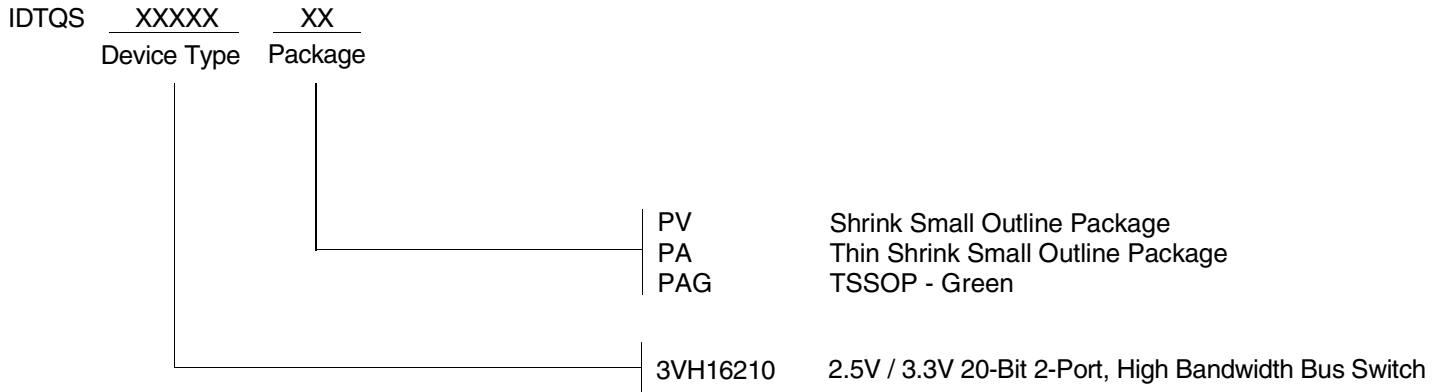

**CORPORATE HEADQUARTERS**  
2975 Stender Way  
Santa Clara, CA 95054

**for SALES:**  
800-345-7015 or 408-727-6116  
fax: 408-492-8674  
www.idt.com

**for Tech Support:**  
logichelp@idt.com  
(408) 654-6459