



PI49FCT805T
PI49FCT2805T
PI49FCT806T
Fast CMOS
Buffer/Clock Driver

Product Features

- Extremely low output skew: 0.5ns
- Monitor output pin
- Clock busing with Hi-Z state control
- TTL input and CMOS output compatible
- Extremely low static power (1mW, typ.)
- Hysteresis on all inputs
- Packages available:
 - 20-pin 209 mil wide SSOP (H)
 - 20-pin 300 mil wide SOIC (S)
 - 20-pin 150 mil wide QSOP (Q)
- Device models available on request
- Industrial Operation at -40°C to +85°C

Product Description

Pericom Semiconductor's PI49FCT series of logic circuits are produced using the Company's advanced 0.8 micron CMOS technology, achieving industry leading speed grades.

The PI49FCT805T and PI49FCT2805T are non-inverting clock drivers. The PI49FCT806T is an inverting clock driver designed with two independent groups of buffers that have Hi-Z state Output Enable inputs (active LOW) with a 1-in, 5-out configuration per group. Each clock driver consists of two banks of drivers, driving five outputs each from a standard TTL-compatible CMOS input.

The PI49FCT2805T also features a 25-ohm on-chip resistor for lower noise.

PI49FCT805T/2805T Logic Block Diagram

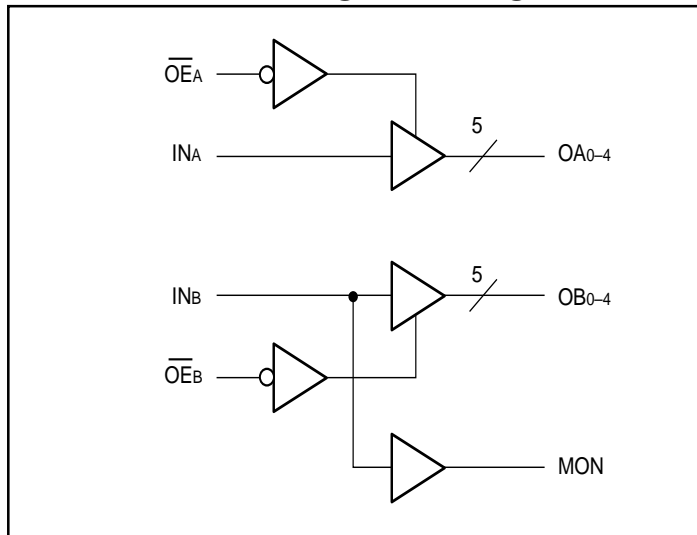

PI49FCT806T Logic Block Diagram

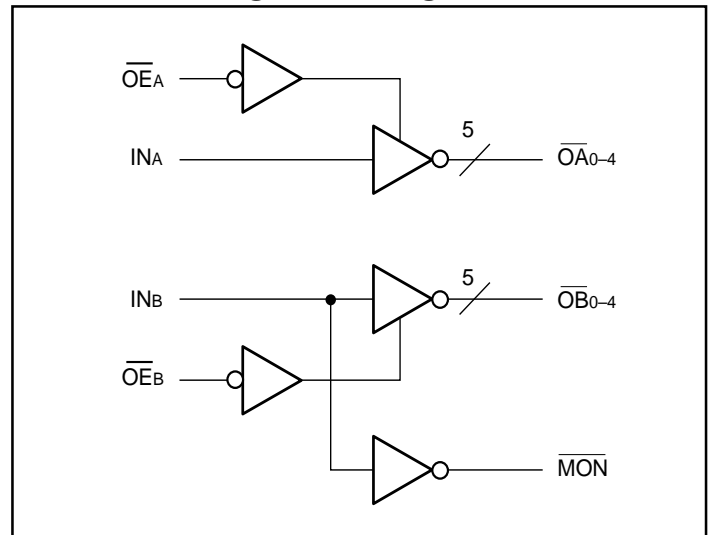



Product Pin Description

Pin Name	Description
$\overline{OE}_A, \overline{OE}_B$	Hi-Z State Output Enable Inputs (Active LOW)
IN_A, IN_B	Clock Inputs
OA_N, OB_N	Clock Outputs (PI49FCT805T/PI49FCT2805T)
$\overline{OA}_N, \overline{OB}_N$	Clock Output (PI49FCT806T)
MON	Monitor Output
GND	Ground
V _{CC}	Power

PI49FCT805T/2805T Truth Table⁽¹⁾

Inputs		Outputs	
$\overline{OE}_A, \overline{OE}_B$	IN_A, IN_B	OA_N, OB_N	MON
L	L	L	L
L	H	H	H
H	L	Z	L
H	H	Z	H

PI49FCT806T Truth Table⁽¹⁾

Inputs		Outputs	
$\overline{OE}_A, \overline{OE}_B$	IN_A, IN_B	$\overline{OA}_N, \overline{OB}_N$	\overline{MON}
L	L	H	H
L	H	L	L
H	L	Z	H
H	H	Z	L

Note:

1. H= High Voltage Level
 L= Low Voltage Level
 Z= High Impedance

PI49FCT805T/2805T Product Pin Configuration

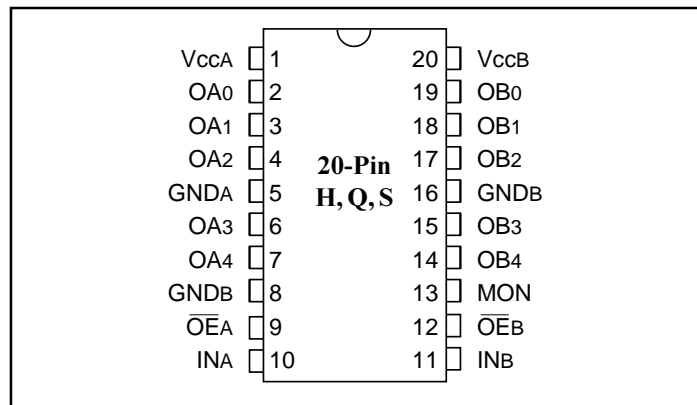

PI49FCT806T Product Pin Configuration

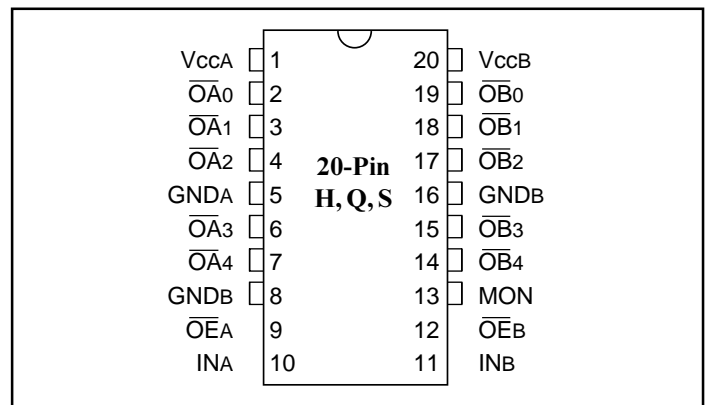



Maximum Ratings

(Above which the useful life may be impaired. For user guidelines, not tested.)

Storage Temperature	-65°C to +150°C
Ambient Temperature with Power Applied	-40°C to +85°C
Supply Voltage to Ground Potential (Inputs & V _{CC} Only)	-0.5V to +7.0V
Supply Voltage to Ground Potential (Outputs & D/O Only)	-0.5V to +7.0V
DC Input Voltage	-0.5V to +7.0V
DC Output Current	120mA
Power Dissipation	0.5W

Note:

Stresses greater than those listed under MAXIMUM RATINGS may cause permanent damage to the device. This is a stress rating only and functional operation of the device at these or any other conditions above those indicated in the operational sections of this specification is not implied. Exposure to absolute maximum rating conditions for extended periods may affect reliability.

DC Electrical Characteristics (Over the Operating Range, T_A = -40°C to +85°C, V_{CC} = 5.0V ± 5%)

Parameters	Description	Test Conditions ⁽¹⁾		Min.	Typ ⁽²⁾	Max.	Units
V _{OH}	Output HIGH Voltage	V _{CC} = Min., V _{IN} = V _{IH} or V _{IL}	I _{OH} = -24.0mA	2.4	3.3		V
V _{OL}	Output LOW Current	V _{CC} = Min., V _{IN} = V _{IH} or V _{IL}	I _{OL} = 64mA		0.3	0.55	V
			I _{OL} = 12mA (25Ω)		0.3	0.50	V
V _{IH}	Input HIGH Voltage	Guaranteed Logic HIGH Level		2.0			V
V _{IL}	Input LOW Voltage	Guaranteed Logic LOW Level				0.8	V
I _{IH}	Input HIGH Current	V _{CC} = Max.	V _{IN} = V _{CC}			1	μA
I _{IL}	Input LOW Current	V _{CC} = Max.	V _{IN} = GND			-1	μA
I _{OZH}	High Impedance	V _{CC} = Max.	V _{OUT} = V _{CC}			1	μA
I _{OZL}	Output Current		V _{OUT} = GND			-1	μA
I _I	Input HIGH Current	V _{CC} = Max., V _{IN} = V _{CC} (Max.)				20	μA
V _{IK}	Clamp Diode Voltage	V _{CC} = Min., I _{IN} = -18mA			-0.7	-1.2	V
I _{OS}	Short Circuit Current	V _{CC} = Max. ⁽³⁾ , V _{OUT} = GND		-60	-120	-225	mA
V _H	Input Hysteresis	V _{CC} = 5V			200		mV

Capacitance (T_A = 25°C, f = 1 MHz)

Parameters ⁽⁴⁾	Description	Test Conditions	Typ	Max.	Units
C _{IN}	Input Capacitance	V _{IN} = 0V	6	10	pF
C _{OUT}	Output Capacitance	V _{OUT} = 0V	8	12	pF

Notes:

1. For Max. or Min. conditions, use appropriate value specified under Electrical Characteristics for the applicable device type.
2. Typical values are at V_{CC} = 5.0V, +25°C ambient and maximum loading.
3. Not more than one output should be shorted at one time. Duration of the test should not exceed one second.
4. This parameter is determined by device characterization but is not production tested.



Power Supply Characteristics

Parameters	Description	Test Conditions ⁽¹⁾		Min.	Typ ⁽²⁾	Max.	Units
I _{CC}	Quiescent Power Supply Current	V _{CC} =Max.	V _{IN} =GND or V _{CC}		3	30	μA
ΔI _{CC}	Supply Current per Input @ TTL HIGH	V _{CC} =Max.	V _{IN} =3.4V ⁽³⁾		0.5	2.0	mA
I _{CCD}	Supply Current per Input per MHz ⁽⁴⁾	V _{CC} =Max., Outputs Open $\overline{OE}_A = \overline{OE}_B = \text{GND}$ Per Output Toggling 50% Duty Cycle	V _{IN} =V _{CC} V _{IN} =GND		0.15	0.25	mA/ MHz
I _C	Total Power Supply Current ⁽⁶⁾	V _{CC} =Max., Outputs Open f _i = 10 MHz 50% Duty Cycle $\overline{OE}_A = \overline{OE}_B = \text{GND}$ Five Outputs Toggling	V _{IN} =V _{CC} V _{IN} =GND		7.7	14.0 ⁽⁵⁾	mA
			V _{IN} =3.4V V _{IN} =GND		8.0	15.0 ⁽⁵⁾	
		V _{CC} =Max., Outputs Open f _i = 2.5 MHz 50% Duty Cycle $\overline{OE}_A = \overline{OE}_B = \text{GND}$ Eleven Outputs Toggling	V _{IN} =V _{CC} V _{IN} =GND		4.3	8.4 ⁽⁵⁾	
			V _{IN} =3.4V V _{IN} =GND		4.8	10.4 ⁽⁵⁾	

Notes:

1. For Max. or Min. conditions, use appropriate value specified under Electrical Characteristics for the applicable device.
2. Typical values are at V_{CC} = 5.0V, +25°C ambient.
3. Per TTL driven input (V_{IN} = 3.4V); all other inputs at V_{CC} or GND.
4. This parameter is not directly testable, but is derived for use in Total Power Supply Calculations.
5. Values for these conditions are examples of the I_{CC} formula. These limits are guaranteed but not tested.
6. $I_C = I_{\text{QUIESCENT}} + I_{\text{INPUTS}} + I_{\text{DYNAMIC}}$
 $I_C = I_{CC} + \Delta I_{CC} D_H N_T + I_{CCD} (f_{CP}/2 + f_i N_i)$
 I_{CC} = Quiescent Current
 ΔI_{CC} = Power Supply Current for a TTL High Input (V_{IN} = 3.4V)
 D_H = Duty Cycle for TTL Inputs High
 N_T = Number of TTL Inputs at D_H
 I_{CCD} = Dynamic Current Caused by an Input Transition Pair (HLH or LHL)
 f_{CP} = Clock Frequency for Register Devices (Zero for Non-Register Devices)
 f_i = Input Frequency
 N_i = Number of Inputs at f_i
 All currents are in milliamps and all frequencies are in megahertz.

PI49FCT805/806T Switching Characteristics over Operating Range

Parameters	Description	Conditions ⁽¹⁾	805T/2805T/ 806T		805AT/2805AT/ 806AT		805BT/2805BT/ 806BT		805CT/2805CT/ 806CT		Units
			Com.		Com		Com.		Com		
			Min.	Max.	Min.	Max.	Min.	Max.	Min.	Max.	
t_{PLH} t_{PHL}	Propagation Delay IN_A to OA_N , IN_B to OB_N	CL = 50pF RL = 500Ω	1.5	6.5	1.5	5.8	1.5	5.0	1.5	4.5	ns
t_{PZH} t_{PZL}	Output Enable Time \overline{OE}_A to \overline{OA}_N , \overline{OE}_B to \overline{OB}_N		1.5	8.0	1.5	8.0	1.5	8.5	1.5	6.2	
t_{PHZ} t_{PLZ}	Output Disable Time ⁽⁴⁾ \overline{OE}_A to \overline{OA}_N , \overline{OE}_B to \overline{OB}_N		1.5	7.0	1.5	7.0	1.5	6.0	1.5	5.0	
$t_{SKEW(o)}$ ⁽³⁾	Skew twx two outputs of same package (same transition)		—	0.7	—	0.5	—	0.4	—	0.4	
$t_{SKEW(p)}$ ⁽³⁾	Skew twx opposite transitions (t_{PHL} - t_{PLH}) of same output		—	1.0	—	0.7	—	0.5	—	0.5	
$t_{SKEW(t)}$ ⁽³⁾	Skew twx two outputs of different package at same temperature (same transition)		—	1.5	—	1.0	—	1.0	—	1.0	

Notes:

1. See test circuit and wave forms.
2. Minimum limits are guaranteed but not tested on Propagation Delays.
3. Skew measured at worse cast temperature (max. temp).
4. This parameter is guaranteed but not production tested.

Tests Circuits For All Outputs⁽¹⁾

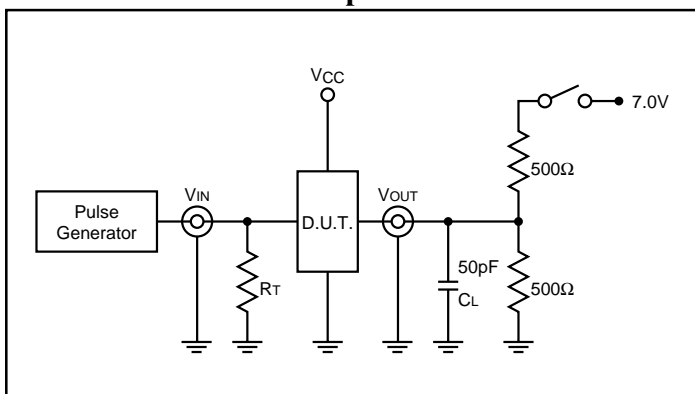

Switch Position

Test	Switch
Open Drain Disable LOW Enable LOW	Closed
All Other Inputs	Open

Definitions:

C_L = Load capacitance: includes jig and probe capacitance.
 R_T = Termination resistance: should be equal to Z_{OUT} of the Pulse Generator.

Switching Waveforms

Propagation Delay

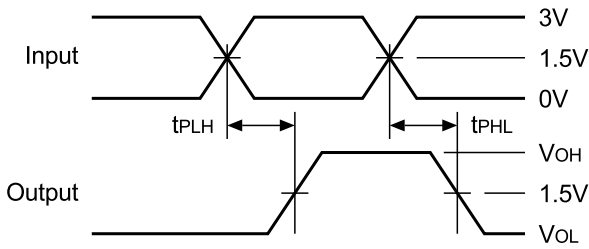

Enable and Disable Times

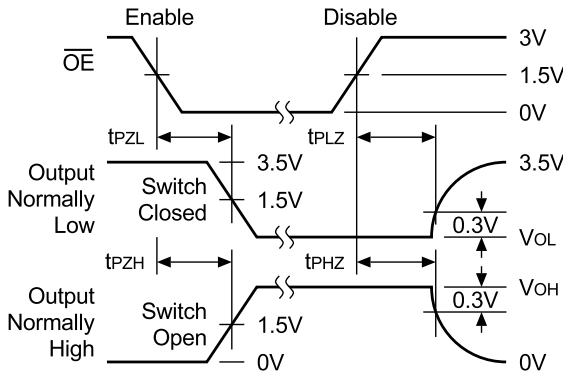

Package Skew – $t_{sk}(t)$

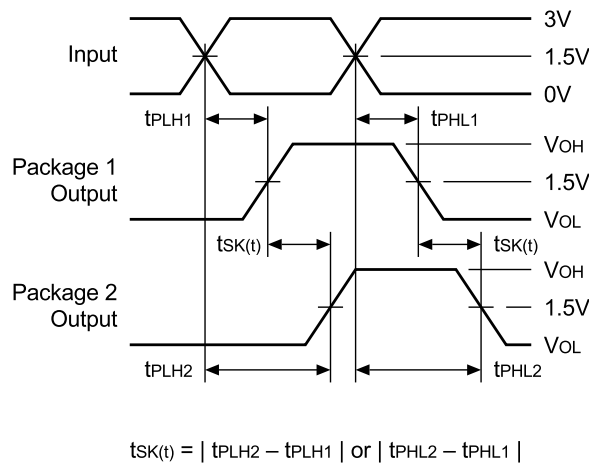

Output Skew – $t_{sk}(o)$

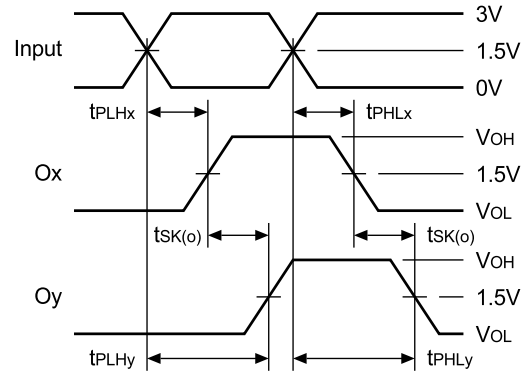

$$t_{sk}(o) = |t_{PLHy} - t_{PLHx}| \text{ or } |t_{PHLy} - t_{PHLx}|$$

Pulse Skew – $t_{sk}(p)$

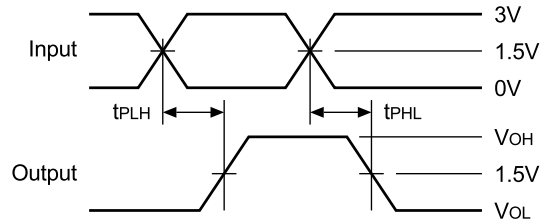

$$t_{sk}(p) = |t_{PHL} - t_{PLH}|$$

20-Pin 209-Mil SSOP (H)

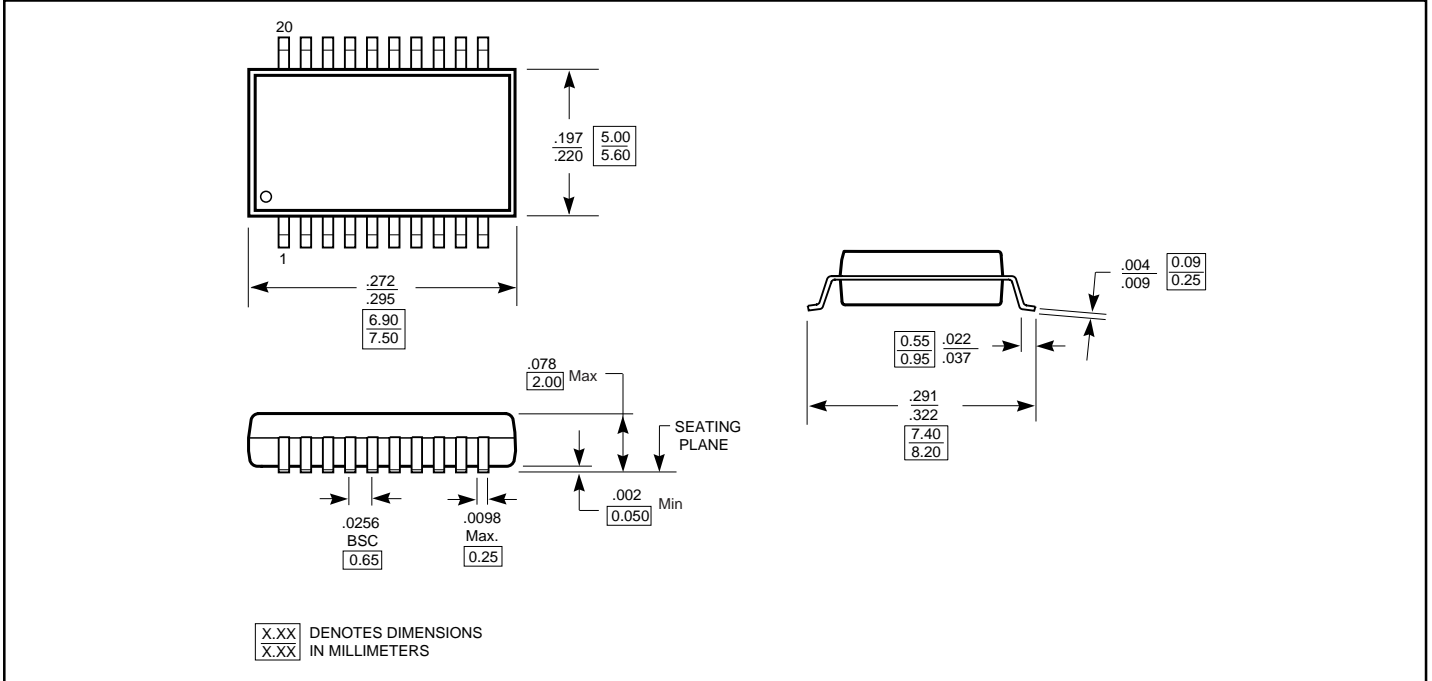

20-Pin 150-Mil QSOP (Q)

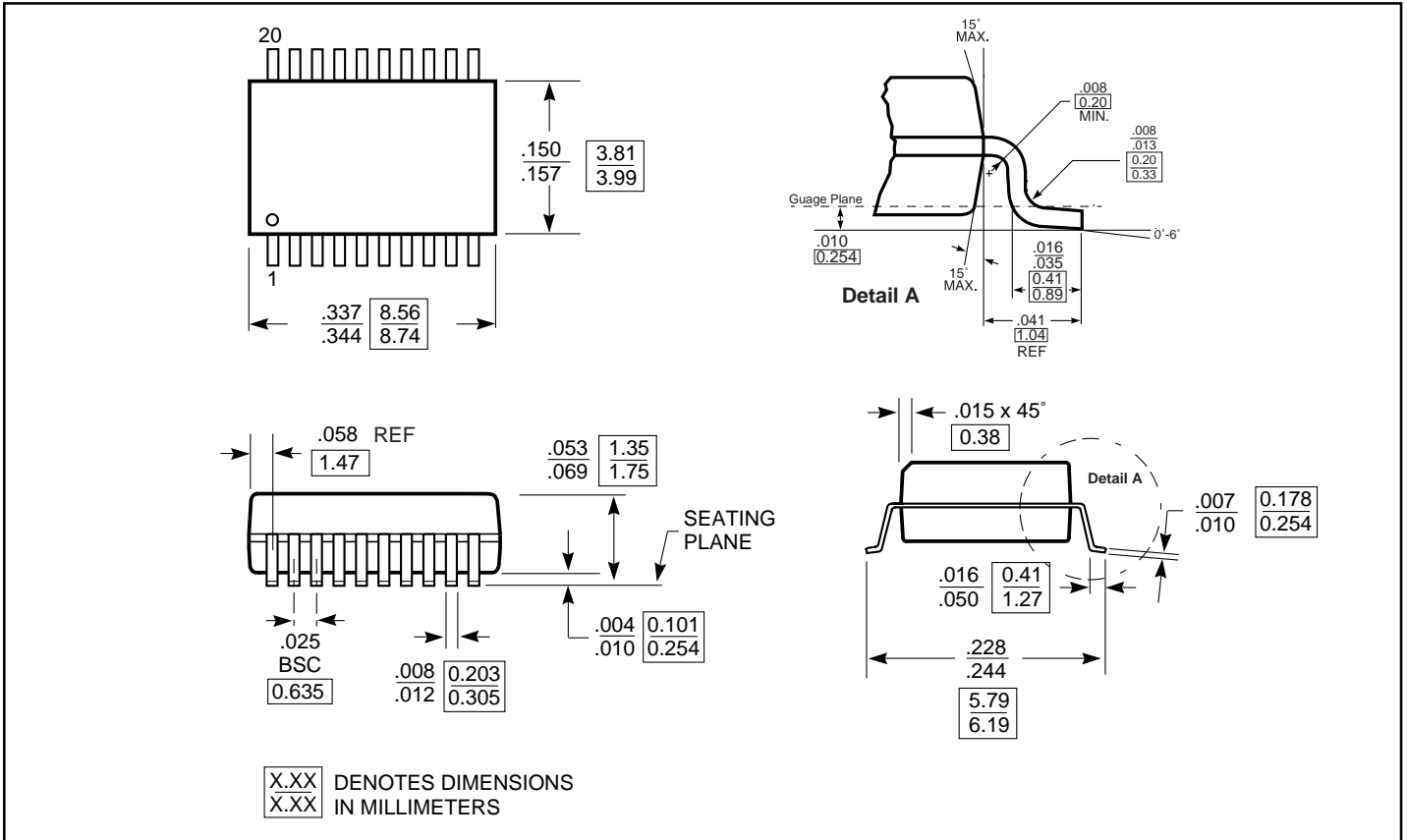

20-Pin 300-Mil SOIC (S)

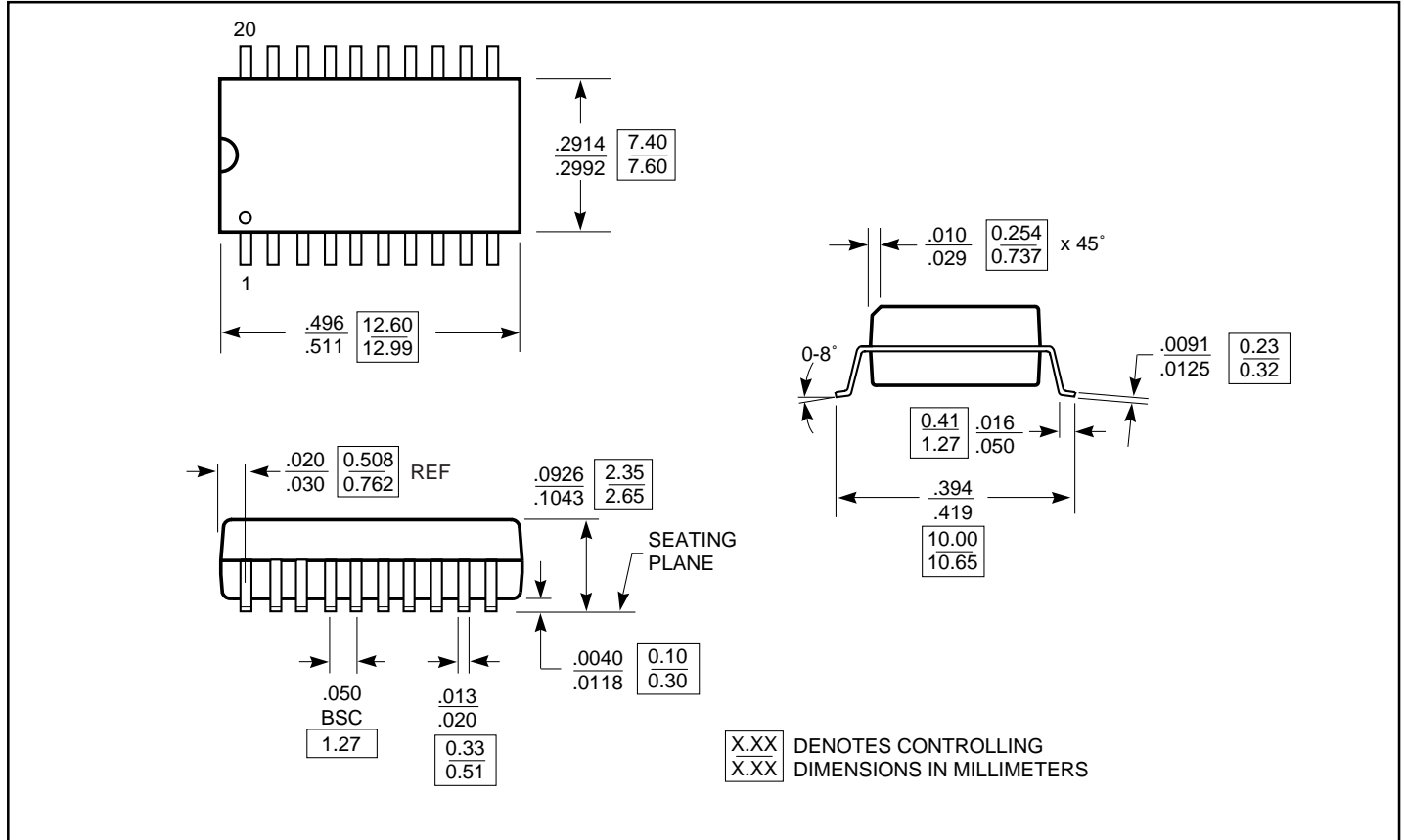

Ordering Information

Ordering Code	Marking Code
PI49FCT805xTp	PI49FCT805Tpx
PI49FCT2805xTp	PI49FCT2805Tpx
PI49FCT806xTp	PI49FCT806Tpx

Note: x = Speed Grades: "blank", A, B, C.
 p = Package Type:
 H=209-mil SSOP
 Q=150-mil QSOP
 S=300-mil SOIC

Example:
 PI49FCT2805ATH = A grade, H pkg marked as PI49FCT2805THA