

DATA SHEET



SAA5360; SAA5361 Multi page intelligent teletext decoder

Product specification
Supersedes data of 2005 Jan 25

2005 Mar 09

Multi page intelligent teletext decoder**SAA5360; SAA5361**

CONTENTS	13	PACKAGE OUTLINE
1 FEATURES	14	SOLDERING
2 GENERAL DESCRIPTION	14.1	Introduction to soldering surface mount packages
3 QUICK REFERENCE DATA	14.2	Reflow soldering
4 ORDERING INFORMATION	14.3	Wave soldering
5 BLOCK DIAGRAM	14.4	Manual soldering
6 PINNING	14.5	Suitability of surface mount IC packages for wave and reflow soldering methods
6.1 Type SAA5360	15	DATA SHEET STATUS
6.2 Type SAA5361	16	DEFINITIONS
7 COMMANDS AND CHARACTER SETS	17	DISCLAIMERS
7.1 High-level command interface	18	PURCHASE OF PHILIPS I²C COMPONENTS
7.2 Character sets		
8 LIMITING VALUES		
9 THERMAL CHARACTERISTICS		
10 QUALITY AND RELIABILITY		
11 CHARACTERISTICS		
12 APPLICATION INFORMATION		
12.1 EMC guidelines		
12.2 Application diagram		
12.3 Application notes		
12.3.1 External data memory access		
12.3.2 Symbol explanations		

Multi page intelligent teletext decoder

SAA5360; SAA5361

1 FEATURES

- Support for 50 or 60 and 100 or 120 Hz and progressive scan display modes
- Complete 625 line teletext decoder in one chip reduces printed-circuit board area and cost
- Automatic detection of transmitted fasttext links or service information (packet 8/30)
- On-Screen Display (OSD) for user interface menus using teletext and dedicated menu icons
- Video Programming System (VPS) decoding
- Wide Screen Signalling (WSS) decoding
- SAA5360 supports Pan-European, Arabic and Iranian character sets
- SAA5361 supports Pan-European, Cyrillic, Greek and Arabic character sets
- High-level command interface via I²C-bus gives easy control with a low software overhead
- High-level command interface is backward compatible to Stand-Alone Fasttext And Remote Interface (SAFARI)
- 625 and 525 line display
- RGB interface to standard colour decoder ICs; current source
- Versatile 8-bit open-drain Input/Output (I/O) expander; 5 V tolerant
- Single 12 MHz crystal oscillator
- Single power supply: from 3.0 V to 3.6 V
- Operating temperature: -20 to +70 °C



- Automatic detection of transmitted pages to be selected by page up and page down
- 8 page fasttext decoder
- Table Of Pages (TOP) decoder with Basic Top Table (BTT) and Additional Information Tables (AITs)
- 4 page user-defined list mode.

2 GENERAL DESCRIPTION

The SAA5360; SAA5361 is a single-chip multi page 625 line world system teletext decoder with a high-level command interface, and is SAFARI compatible.

The device is designed to minimize the overall system cost, due to the high-level command interface offering the benefit of a low software overhead in the TV microcontroller.

The SAA5360 incorporates the following functions:

- 10 page teletext decoder with OSD, fasttext, TOP, default and list acquisition modes
- Automatic channel installation support.

The functionality of the SAA5361 is similar to the SAA5360, but offers the capability to store up to 250 additional pages of teletext in an external SRAM.

3 QUICK REFERENCE DATA

SYMBOL	PARAMETER	CONDITIONS	MIN.	TYP.	MAX.	UNIT
V _{DD}	all supply voltages	referenced to V _{SS}	3.0	3.3	3.6	V
I _{DDP}	periphery supply current	note 1	1	–	–	mA
I _D DC	core supply current	normal mode	–	15	18	mA
		idle mode	–	4.6	6	mA
I _D DA	analog supply current	normal mode	–	45	48	mA
		idle mode	–	0.87	1	mA
f _{xtal(nom)}	nominal crystal frequency	fundamental mode	–	12	–	MHz
T _{amb}	ambient temperature		-20	–	+70	°C
T _{stg}	storage temperature		-55	–	+125	°C

Note

1. Periphery supply current is dependent on external components and I/O voltage levels.

Multi page intelligent teletext decoder

SAA5360; SAA5361

4 ORDERING INFORMATION

TYPE NUMBER	PACKAGE		
	NAME	DESCRIPTION	VERSION
SAA5360HL	LQFP100	plastic low profile quad flat package; 100 leads; body 14 × 14 × 1.4 mm	SOT407-1
SAA5361HL	LQFP100	plastic low profile quad flat package; 100 leads; body 14 × 14 × 1.4 mm	SOT407-1

5 BLOCK DIAGRAM

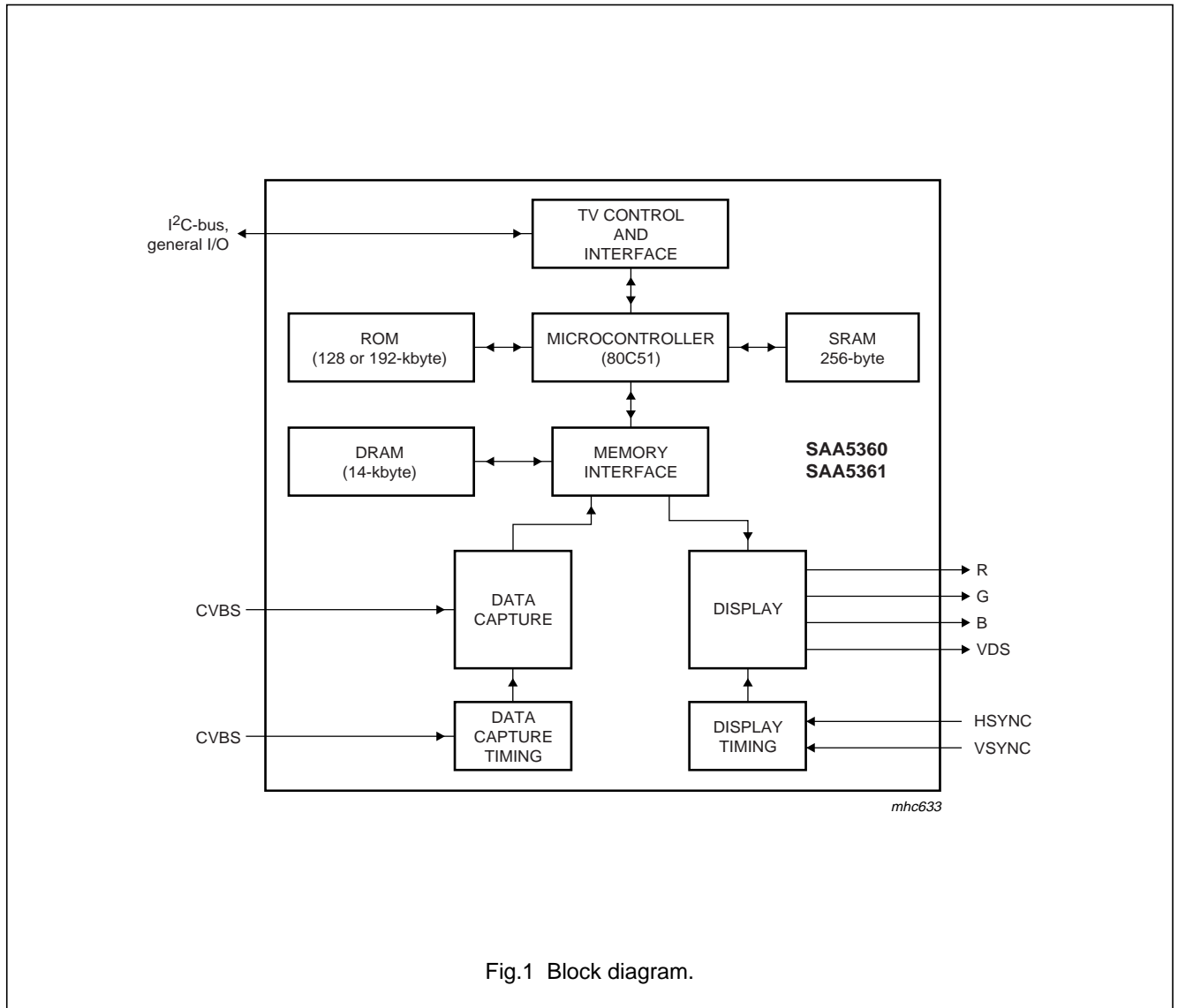

Fig.1 Block diagram.

Multi page intelligent teletext decoder

SAA5360; SAA5361

6 PINNING

6.1 Type SAA5360

SYMBOL	PIN	TYPE	DESCRIPTION
P2_7/PWM6	1	I/O	programmable bidirectional port 2: bit 7 or output bit 6 of the 7-bit PWM
P3_0/ADC0	2	I/O	programmable bidirectional port 3: bit 0 or input 0 for the software ADC facility
n.c.	3	–	not connected
P3_1/ADC1	4	I/O	programmable bidirectional port 3: bit 1 or input 1 for the software ADC facility
P3_2/ADC2	5	I/O	programmable bidirectional port 3: bit 2 or input 2 for the software ADC facility
P3_3/ADC3	6	I/O	programmable bidirectional port 3: bit 3 or input 3 for the software ADC facility
n.c.	7	–	not connected
n.c.	8	–	not connected
n.c.	9	–	not connected
n.c.	10	–	not connected
V _{SSC}	11	–	core ground
V _{SSP}	12	–	periphery ground
P0_5	13	I/O	8 mA current sinking output for direct drive of LED
n.c.	14	–	not connected
n.c.	15	–	not connected
SCL_NVRAM	16	I	I ² C-bus serial clock input to non-volatile RAM
SDA_NVRAM	17	I/O	I ² C-bus serial data input and output of non-volatile RAM
P0_2	18	I/O	programmable bidirectional port 0: bit 2
n.c.	19	–	not connected
n.c.	20	–	not connected
VPE	21	I	OTP programming voltage input; connect to ground
P0_3	22	I/O	programmable bidirectional port 0: bit 3
n.c.	23	–	not connected
P0_4	24	I/O	programmable bidirectional port 0: bit 4
n.c.	25	–	not connected
n.c.	26	–	not connected
n.c.	27	–	not connected
P0_6	28	I/O	8 mA current sinking output for direct drive of LED
P0_7	29	I/O	programmable bidirectional port 0: bit 7
V _{SSA}	30	–	analog ground
CVBS0	31	I	composite video input 0 selectable via SFR; a positive-going 1 V (p-p) input is required and connected via a 100 nF capacitor
CVBS1	32	I	composite video input 1 selectable via SFR; a positive-going 1 V (p-p) input is required and connected via a 100 nF capacitor
n.c.	33	–	not connected
SYNC_FILTER	34	I/O	CVBS sync filter input; this pin should be connected to V _{SSA} via a 100 nF capacitor
IREF	35	I	reference current input for analog circuits and connected to V _{SSA} via a 24 k Ω resistor

Multi page intelligent teletext decoder

SAA5360; SAA5361

SYMBOL	PIN	TYPE	DESCRIPTION
n.c.	36	–	not connected
n.c.	37	–	not connected
n.c.	38	–	not connected
n.c.	39	–	not connected
n.c.	40	–	not connected
FRAME	41	O	de-interlace output synchronized with the VSYNC pulse to produce a non-interlaced display by adjustment of the vertical deflection circuits
VPE	42	I	OTP programming voltage input; connect to ground
COR	43	O	output which allows selective contrast reduction of the TV picture to enhance a mixed mode display; open-drain; active LOW
n.c.	44	–	not connected
V _{DDA}	45	–	3.3 V analog supply voltage
B	46	O	pixel rate output of the blue colour information
G	47	O	pixel rate output of the green colour information
R	48	O	pixel rate output of the red colour information
n.c.	49	–	not connected
n.c.	50	–	not connected
n.c.	51	–	not connected
VDS	52	O	video or data switch push-pull output for dot rate fast blanking
HSYNC	53	I	Schmitt-triggered input for a TTL-level version of the horizontal sync pulse; the polarity of this pulse is programmable by register bit TXT1.H POLARITY
n.c.	54	–	not connected
VSYNC	55	I	Schmitt-triggered input for a TTL-level version of the vertical sync pulse; the polarity of this pulse is programmable by register bit TXT1.V POLARITY
n.c.	56	–	not connected
n.c.	57	–	not connected
n.c.	58	–	not connected
n.c.	59	–	not connected
V _{SSP}	60	–	periphery ground
n.c.	61	–	not connected
V _{SSC}	62	–	core ground
V _{DDC}	63	–	3.3 V core supply voltage
n.c.	64	–	not connected
n.c.	65	–	not connected
n.c.	66	–	not connected
n.c.	67	–	not connected
n.c.	68	–	not connected
OSCGND	69	–	crystal oscillator ground
XTALIN	70	I	12 MHz crystal oscillator input
XTALOUT	71	O	12 MHz crystal oscillator output
RESET	72	I	reset input; if LOW for at least 24 crystal oscillator periods while the oscillator is running, the device is reset; internal pull-up

Multi page intelligent teletext decoder

SAA5360; SAA5361

SYMBOL	PIN	TYPE	DESCRIPTION
RESET	73	I	reset input; if HIGH for at least 24 crystal oscillator periods while the oscillator is running, the device is reset; this pin should be connected to V_{DDC} via a capacitor if an active HIGH reset is required; internal pull-down
n.c.	74	–	not connected
V_{DDP}	75	–	3.3 V periphery supply voltage
P1_0	76	I/O	programmable bidirectional port 1: bit 0
n.c.	77	–	not connected
P1_1	78	I/O	programmable bidirectional port 1: bit 1
P1_2	79	I/O	programmable bidirectional port 1: bit 2
P1_3	80	I/O	programmable bidirectional port 1: bit 3
SCL	81	I	I ² C-bus serial clock input from application
SDA	82	I/O	I ² C-bus serial data input from or output to application
P1_4	83	I/O	programmable bidirectional port 1: bit 4
P1_5	84	I/O	programmable bidirectional port 1: bit 5
n.c.	85	–	not connected
n.c.	86	–	not connected
n.c.	87	–	not connected
n.c.	88	–	not connected
n.c.	89	–	not connected
n.c.	90	–	not connected
n.c.	91	–	not connected
n.c.	92	–	not connected
P2_1/PWM0	93	I/O	programmable bidirectional port 2: bit 1 or output bit 0 of the 7-bit PWM
P2_2/PWM1	94	I/O	programmable bidirectional port 2: bit 2 or output bit 1 of the 7-bit PWM
P2_3/PWM2	95	I/O	programmable bidirectional port 2: bit 3 or output bit 2 of the 7-bit PWM
P2_4/PWM3	96	I/O	programmable bidirectional port 2: bit 4 or output bit 3 of the 7-bit PWM
P2_5/PWM4	97	I/O	programmable bidirectional port 2: bit 5 or output bit 4 of the 7-bit PWM
P2_6/PWM5	98	I/O	programmable bidirectional port 2: bit 6 or output bit 5 of the 7-bit PWM
V_{SSC}	99	–	core ground
P2_0/TPWM	100	I/O	programmable bidirectional port 2: bit 0 or output for 14-bit high precision PWM

Multi page intelligent teletext decoder

SAA5360; SAA5361

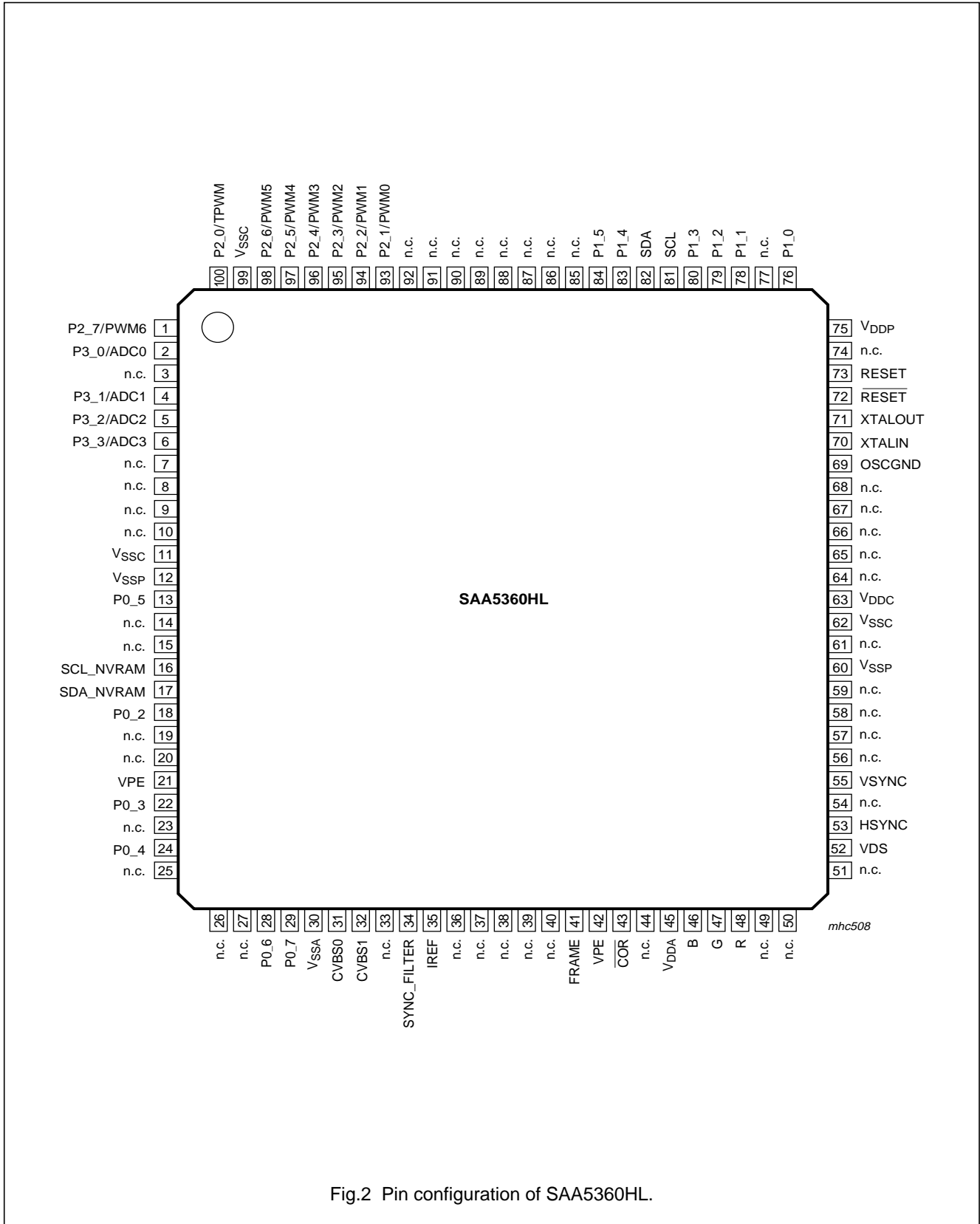

Fig.2 Pin configuration of SAA5360HL.

Multi page intelligent teletext decoder

SAA5360; SAA5361

6.2 Type SAA5361

SYMBOL	PIN	TYPE	DESCRIPTION
P2_7/PWM6	1	I/O	programmable bidirectional port 2: bit 7 or output bit 6 of the 6-bit PWM
P3_0/ADC0	2	I/O	programmable bidirectional port 3 with alternative functions: bit 0 or input 0 for the software ADC facility
n.c.	3	O	not connected
P3_1/ADC1	4	I/O	programmable bidirectional port 3 with alternative functions: bit 1 or input 1 for the software ADC facility
P3_2/ADC2	5	I/O	programmable bidirectional port 3 with alternative functions: bit 2 or input 2 for the software ADC facility
P3_3/ADC3	6	I/O	programmable bidirectional port 3 with alternative functions: bit 3 or input 3 for the software ADC facility
n.c.	7	O	not connected
A14	8	O	address line 14
\overline{RD}	9	O	read control output to external data memory; active LOW
\overline{WR}	10	O	write control output to external data memory; active LOW
V _{SSC}	11	-	core ground
V _{SSP}	12	-	periphery ground
P0_5	13	I/O	8 mA current sinking output for direct drive of LED
n.c.	14	I	not connected
A7	15	O	address line 7
SCL_NVRAM	16	I	I ² C-bus serial clock input to non-volatile RAM
SDA_NVRAM	17	I/O	I ² C-bus serial data input and output of non-volatile RAM
P0_2	18	I/O	programmable bidirectional port 0 with alternative functions: bit 2 input and output for general use
n.c.	19	O	not connected
n.c.	20	O	not connected
VPE	21	I	OTP programming voltage input; connect to ground
P0_3	22	I/O	programmable bidirectional port 0 with alternative functions: bit 3 input and output for general use
A6	23	O	address line 6
P0_4	24	I/O	programmable bidirectional port 0 with alternative functions: bit 4 input and output for general use
n.c.	25	I/O	not connected
A5	26	O	address line 5
A4	27	O	address line 4
P0_6	28	I/O	8 mA current sinking output for direct drive of LED
P0_7	29	I/O	programmable bidirectional port 0 with alternative functions: bit 7 input and output for general use
V _{SSA}	30	-	analog ground
CVBS0	31	I	composite video input 0 selectable via SFR; a positive-going 1 V (p-p) input is required and connected via a 100 nF capacitor
CVBS1	32	I	composite video input 1 selectable via SFR; a positive-going 1 V (p-p) input is required and connected via a 100 nF capacitor

Multi page intelligent teletext decoder

SAA5360; SAA5361

SYMBOL	PIN	TYPE	DESCRIPTION
A15_BK	33	O	address line 15
SYNC_FILTER	34	I/O	CVBS sync filter input; this pin should be connected to V_{SSA} via a 100 nF capacitor
IREF	35	I	reference current input for analog circuits and connected to V_{SSA} via a 24 k Ω resistor
A13	36	O	address line 13
A12	37	O	address line 12
A3	38	O	address line 3
A2	39	O	address line 2
A1	40	O	address line 1
FRAME	41	O	de-interlace output synchronized with the VSYNC pulse to produce a non-interlaced display by adjustment of the vertical deflection circuits
VPE	42	I	OTP programming voltage input; connect to ground
\overline{COR}	43	O	output which allows selective contrast reduction of the TV picture to enhance a mixed mode display; open-drain; active LOW
n.c.	44	I/O	not connected
V_{DDA}	45	-	3.3 V analog supply voltage
B	46	O	pixel rate output of the blue colour information
G	47	O	pixel rate output of the green colour information
R	48	O	pixel rate output of the red colour information
A0	49	O	address line 0
RAMBK1	50	O	RAMBK SFR selection bits input 1 for external program SRAM data storage
RAMBK0	51	O	RAMBK SFR selection bits input 0 for external program SRAM data storage
VDS	52	O	video or data switch push-pull output for dot rate fast blanking
HSYNC	53	I	Schmitt-triggered input for a TTL-level version of the horizontal sync pulse; the polarity of this pulse is programmable by register bit TXT1.H POLARITY
n.c.	54	I/O	not connected
VSYNC	55	I	Schmitt-triggered input for a TTL-level version of the vertical sync pulse; the polarity of this pulse is programmable by register bit TXT1.V POLARITY
n.c.	56	O	not connected
n.c.	57	O	not connected
n.c.	58	O	not connected
n.c.	59	I/O	not connected
V_{SSP}	60	-	periphery ground
n.c.	61	I	not connected (internal pull-up)
V_{SSC}	62	-	core ground
V_{DDC}	63	-	3.3 V core supply voltage
A11	64	O	address line 11
A10	65	O	address line 10
A9	66	O	address line 9
A8	67	O	address line 8
n.c.	68	O	not connected
OSCGND	69	-	crystal oscillator ground

Multi page intelligent teletext decoder

SAA5360; SAA5361

SYMBOL	PIN	TYPE	DESCRIPTION
XTALIN	70	I	12 MHz crystal oscillator input
XTALOUT	71	O	12 MHz crystal oscillator output
RESET	72	I	reset input; if LOW for at least 24 crystal oscillator periods while the oscillator is running, the device is reset; internal pull-up
RESET	73	I	reset input; if HIGH for at least 24 crystal oscillator periods while the oscillator is running, the device is reset; this pin should be connected to V_{DDC} via a capacitor if an active HIGH reset is required; internal pull-down
n.c.	74	O	not connected
V_{DDP}	75	-	3.3 V periphery supply voltage
P1_0	76	I/O	programmable bidirectional port 1 with alternative functions: bit 0 input and output for general use
n.c.	77	O	not connected
P1_1	78	I/O	programmable bidirectional port 1 with alternative functions: bit 1 input and output for general use
P1_2	79	I/O	programmable bidirectional port 1 with alternative functions: bit 2 input and output for general use
P1_3	80	I/O	programmable bidirectional port 1 with alternative functions: bit 3 input and output for general use
SCL	81	I	I ² C-bus serial clock input from application
SDA	82	I/O	I ² C-bus serial data input from or output to application
P1_4	83	I/O	programmable bidirectional port 1 with alternative functions: bit 4 input and output for general use
P1_5	84	I/O	programmable bidirectional port 1 with alternative functions: bit 5 input and output for general use
AD0	85	I/O	address line 0 with multiplexed data line 0
AD1	86	I/O	address line 1 with multiplexed data line 1
AD2	87	I/O	address line 2 with multiplexed data line 2
AD3	88	I/O	address line 3 with multiplexed data line 3
AD4	89	I/O	address line 4 with multiplexed data line 4
AD5	90	I/O	address line 5 with multiplexed data line 5
AD6	91	I/O	address line 6 with multiplexed data line 6
AD7	92	I/O	address line 7 with multiplexed data line 7
P2_1/PWM0	93	I/O	programmable bidirectional port 2: bit 1 or output bit 0 of the 6-bit PWM
P2_2/PWM1	94	I/O	programmable bidirectional port 2: bit 2 or output bit 1 of the 6-bit PWM
P2_3/PWM2	95	I/O	programmable bidirectional port 2: bit 3 or output bit 2 of the 6-bit PWM
P2_4/PWM3	96	I/O	programmable bidirectional port 2: bit 4 or output bit 3 of the 6-bit PWM
P2_5/PWM4	97	I/O	programmable bidirectional port 2: bit 5 or output bit 4 of the 6-bit PWM
P2_6/PWM5	98	I/O	programmable bidirectional port 2: bit 6 or output bit 5 of the 6-bit PWM
V_{SSC}	99	-	core ground
P2_0/TPWM	100	I/O	programmable bidirectional port 2: bit 0 or output for 14-bit high precision PWM

Multi page intelligent teletext decoder

SAA5360; SAA5361

7 COMMANDS AND CHARACTER SETS

7.1 High-level command interface

The I²C-bus interface is used to pass control commands and data between the SAA5360; SAA5361 and the television microcontroller. The interface uses high-level commands, which are backwards compatible with the SAFARI.

The I²C-bus transmission formats are given in Tables 1 to 3.

Table 1 User command

USER COMMAND						
START	I ² C-bus address	write	ACK	command	ACK	STOP

Table 2 System command

SYSTEM COMMAND								
START	I ² C-bus address	write	ACK	command	ACK	parameter	ACK	STOP

Table 3 User read

USER READ						
START	I ² C-bus address	read	ACK	data	ACK	STOP

7.2 Character sets

The SAA5360HL/M1/0004 contains the character set for Pan-Euro, Arabic and Iranian and has slave address 58H.

The SAA5361HL/M1/1651 contains the character set for Pan-Euro, Cyrillic, Greek and Arabic and has slave address 60H.

Multi page intelligent teletext decoder

SAA5360; SAA5361

8 LIMITING VALUES

In accordance with Absolute Maximum Rating System (IEC 60134).

SYMBOL	PARAMETER	CONDITIONS	MIN.	MAX.	UNIT
V_{DD}	all supply voltages		-0.5	+4.0	V
V_I	input voltage (any input)	$V_{DD} < 3.6$ V; note 1	-0.5	$V_{DD} + 0.5$	V
		$V_{DD} \geq 3.6$ V; note 1	-0.5	4.1	V
V_O	output voltage (any output)	note 1	-0.5	$V_{DD} + 0.5$	V
I_O	output current (each output)		-	10	mA
$I_{IO(d)}$	diode DC input or output current		-	20	mA
T_{amb}	ambient temperature		-20	+70	°C
T_j	junction temperature		-20	+125	°C
T_{stg}	storage temperature		-55	+125	°C
V_{esd}	electrostatic discharge voltage	Human body model; C = 100 pF; R = 1.5 k Ω	-	2000	V
		Machine model; C = 200 pF; R = 0 Ω	-	200	V
I_{lu}	latch-up current	$1.5 \times V_{DD}$	-	100	mA

Note

1. This maximum value refers to 5 V tolerant I/Os and may be 6 V maximum but only when V_{DD} is present.

9 THERMAL CHARACTERISTICS

SYMBOL	PARAMETER	CONDITIONS	VALUE	UNIT
$R_{th(j-a)}$	thermal resistance from junction to ambient	in free air	52	K/W
$R_{th(j-c)}$	thermal resistance from junction to case		8	K/W

10 QUALITY AND RELIABILITY

In accordance with "General Quality Specification for Integrated circuits SNW-FQ-611".

Multi page intelligent teletext decoder

SAA5360; SAA5361

11 CHARACTERISTICS

$V_{DD} = 3.3 \text{ V} \pm 10 \%$; $V_{SS} = 0 \text{ V}$; $T_{amb} = -20 \text{ }^\circ\text{C}$ to $+70 \text{ }^\circ\text{C}$; unless otherwise specified.

SYMBOL	PARAMETER	CONDITIONS	MIN.	TYP.	MAX.	UNIT
Supplies						
V_{DD}	any supply voltage	referenced to V_{SS}	3.0	3.3	3.6	V
I_{DDP}	periphery supply current	note 1	1	–	–	mA
I_{DDC}	core supply current	operating mode	–	15	18	mA
		idle mode	–	4.6	6	mA
		power-down mode	–	0.76	1	mA
I_{DDA}	analog supply current	operating mode	–	45	48	mA
		idle mode	–	0.87	1	mA
		power-down mode	–	0.45	0.7	mA
Digital inputs						
PIN RESET						
V_{IL}	LOW-level input voltage		–	–	1.00	V
V_{IH}	HIGH-level input voltage		1.85	–	5.5	V
V_{hys}	hysteresis voltage of Schmitt-trigger input		0.44	–	0.58	V
I_{LI}	input leakage current	$V_I = 0$	–	–	0.17	μA
R_{pd}	equivalent pull-down resistance	$V_I = V_{DD}$	55.73	70.71	92.45	k Ω
PIN RESET						
V_{IL}	LOW-level input voltage		–	–	0.98	V
V_{IH}	HIGH-level input voltage		1.73	–	5.5	V
V_{hys}	hysteresis voltage of Schmitt-trigger input		0.41	–	0.5	V
I_{LI}	input leakage current	$V_I = V_{DD}$	–	–	0.00	μA
R_{pu}	equivalent pull-up resistance	$V_I = 0$	46.07	55.94	70.01	k Ω
PINS HSYNC AND VSYNC						
V_{IL}	LOW-level input voltage		–	–	0.96	V
V_{IH}	HIGH-level input voltage		1.80	–	5.5	V
V_{hys}	hysteresis of Schmitt-trigger input		0.40	–	0.56	V
I_{LI}	input leakage current	$V_I = 0$ to V_{DD}	–	–	0.00	μA
Digital outputs						
PINS FRAME AND VDS						
V_{OL}	LOW-level output voltage	$I_{OL} = 3 \text{ mA}$	–	–	0.13	V
V_{OH}	HIGH-level output voltage	$I_{OH} = 3 \text{ mA}$	2.84	–	–	V
$t_{o(r)}$	output rise time	10 % to 90 % of V_{DD} ; $C_L = 70 \text{ pF}$	7.50	8.85	10.90	ns
$t_{o(f)}$	output fall time	10 % to 90 % of V_{DD} ; $C_L = 70 \text{ pF}$	6.70	7.97	10.00	ns

Multi page intelligent teletext decoder

SAA5360; SAA5361

SYMBOL	PARAMETER	CONDITIONS	MIN.	TYP.	MAX.	UNIT
PIN $\overline{\text{COR}}$ (OPEN-DRAIN)						
V_{OL}	LOW-level output voltage	$I_{OL} = 3 \text{ mA}$	–	–	0.14	V
V_{OH}	HIGH-level pull-up output voltage	$I_{OL} = -3 \text{ mA}$; push-pull	2.84	–	–	V
I_{LI}	input leakage current	$V_I = 0 \text{ to } V_{DD}$	–	–	0.12	μA
$t_{o(r)}$	output rise time	10 % to 90 % of V_{DD} ; $C_L = 70 \text{ pF}$	7.20	8.64	11.10	ns
$t_{o(f)}$	output fall time	10 % to 90 % of V_{DD} ; $C_L = 70 \text{ pF}$	4.90	7.34	9.40	ns
Digital input/outputs						
PINS SCL_NVRAM, SDA_NVRAM, P0_4 TO P0_7, P1_0, P1_1, P2_1 TO P2_7 AND P3_0 TO P3_4						
V_{IL}	LOW-level input voltage		–	–	0.98	V
V_{IH}	HIGH-level input voltage		1.78	–	5.50	V
V_{hys}	hysteresis of Schmitt-trigger input		0.41	–	0.55	V
I_{LI}	input leakage current	$V_I = 0 \text{ to } V_{DD}$	–	–	0.01	μA
V_{OL}	LOW-level output voltage	$I_{OL} = 4 \text{ mA}$	–	–	0.18	V
V_{OH}	HIGH-level output voltage	$I_{OH} = -4 \text{ mA}$; push-pull	2.81	–	–	V
$t_{o(r)}$	output rise time	10 % to 90 % of V_{DD} ; $C_L = 70 \text{ pF}$; push-pull	6.50	8.47	10.70	ns
$t_{o(f)}$	output fall time	10 % to 90 % of V_{DD} ; $C_L = 70 \text{ pF}$	5.70	7.56	10.00	ns
PINS P1_2, P1_3 AND P2_0						
V_{IL}	LOW-level input voltage		–	–	0.99	V
V_{IH}	HIGH-level input voltage		1.80	–	5.50	V
V_{hys}	hysteresis voltage of Schmitt-trigger input		0.42	–	0.56	V
I_{LI}	input leakage current	$V_I = 0 \text{ to } V_{DD}$	–	–	0.02	μA
V_{OL}	LOW-level output voltage	$I_{OL} = 4 \text{ mA}$	–	–	0.17	V
V_{OH}	HIGH-level output voltage	$I_{OH} = -4 \text{ mA}$; push-pull	2.81	–	–	V
$t_{o(r)}$	output rise time	10 % to 90 % of V_{DD} ; $C_L = 70 \text{ pF}$; push-pull	7.00	8.47	10.50	ns
$t_{o(f)}$	output fall time	10 % to 90 % of V_{DD} ; $C_L = 70 \text{ pF}$	5.40	7.36	9.30	ns
PINS P0_5 AND P0_6						
V_{IL}	LOW-level input voltage		–	–	0.98	V
V_{IH}	HIGH-level input voltage		1.82	–	5.50	V
I_{LI}	input leakage current	$V_I = 0 \text{ to } V_{DD}$	–	–	0.11	μA
V_{hys}	hysteresis voltage of Schmitt-trigger input		0.42	–	0.58	V
V_{OL}	LOW-level output voltage	$I_{OL} = 8 \text{ mA}$	–	–	0.20	V
V_{OH}	HIGH-level output voltage	$I_{OH} = -8 \text{ mA}$; push-pull	2.76	–	–	V
$t_{o(r)}$	output rise time	10 % to 90 % of V_{DD} ; $C_L = 70 \text{ pF}$; push-pull	7.40	8.22	8.80	ns

Multi page intelligent teletext decoder

SAA5360; SAA5361

SYMBOL	PARAMETER	CONDITIONS	MIN.	TYP.	MAX.	UNIT
$t_{o(f)}$	output fall time	10 % to 90 % of V_{DD} ; $C_L = 70$ pF	4.20	4.57	5.20	ns
PINS P1_4 AND P1_5 (OPEN DRAIN)						
V_{IL}	LOW-level input voltage		–	–	1.08	V
V_{IH}	HIGH-level input voltage		1.99	–	5.50	V
V_{hys}	hysteresis voltage of Schmitt-trigger input		0.49	–	0.60	V
I_{LI}	input leakage current	$V_I = 0$ to V_{DD}	–	–	0.13	μ A
V_{OL}	LOW-level output voltage	$I_{OL} = 8$ mA	–	–	0.35	V
$t_{o(f)}$	output fall time	10 % to 90 % of V_{DD} ; $C_L = 70$ pF	69.70	83.67	103.30	ns
$t_{o(f)(I2C)}$	output fall time in relation to the I ² C-bus specifications	$V_o = 3$ V to 1.5 V at $I_{OL} = 3$ mA; $C_L = 400$ nF	–	57.80	–	ns
Analog inputs						
PINS CVBS0 AND CVBS1						
V_{sync}	sync voltage amplitude		0.1	0.3	0.6	V
$V_{v(p-p)}$	video input voltage amplitude (peak-to-peak value)		0.7	1.0	1.4	V
Z_{source}	source impedance		0	–	250	Ω
V_{IH}	HIGH-level input voltage		3.0	–	$V_{DDA} + 0.3$	V
C_i	input capacitance		–	–	10	pF
PIN IREF						
R_{gnd}	resistance to ground	resistor tolerance 2 %	–	24	–	k Ω
PINS ADC0 TO ADC3						
V_{IH}	HIGH-level input voltage	range = $V_{DDP} - V_{TN}$; note 2	–	–	V_{DDA}	V
C_i	input capacitance		–	–	10	pF
Analog outputs						
PINS R, G AND B						
$I_{o(b)}$	output current (black level)	$V_{DDA} = 3.3$ V	–10	–	+10	μ A
$I_{o(max)}$	output current (maximum Intensity)	$V_{DDA} = 3.3$ V; intensity level code = 31 decimal	6.0	6.67	7.3	mA
$I_{o(70)}$	output current (70 % of full intensity)	$V_{DDA} = 3.3$ V; intensity level code = 0 decimal	4.2	4.7	5.1	mA
R_L	load resistor	referenced to V_{SSA} ; resistor tolerance 5 %	–	150	–	Ω
C_L	load capacitance		–	–	15	pF
$t_{o(r)}$	output rise time	10 % to 90 % full intensity	–	16.1	–	ns
$t_{o(f)}$	output fall time	90 % to 10 % full intensity	–	14.5	–	ns

Multi page intelligent teletext decoder

SAA5360; SAA5361

SYMBOL	PARAMETER	CONDITIONS	MIN.	TYP.	MAX.	UNIT
Analog input/output						
PIN SYNC_FILTER						
C _{sync}	storage capacitor to ground		–	100	–	nF
V _{sync}	sync filter level voltage for nominal sync amplitude		0.35	0.55	0.75	V
Crystal oscillator						
INPUT: PIN XTALIN						
V _{IL}	LOW-level input voltage		V _{SSA}	–	–	V
V _{IH}	HIGH-level input voltage		–	–	V _{DDA}	V
C _i	input capacitance		–	–	10	pF
OUTPUT: PIN XTALOUT						
C _o	output capacitance		–	–	10	pF
Crystal specification; notes 3 and 4						
f _{xtal}	nominal frequency	fundamental mode	–	12	–	MHz
C _L	load capacitance		–	–	30	pF
C _{mot}	motional capacitance	T _{amb} = 25 °C	–	–	20	fF
R _{res}	resonance resistance	T _{amb} = 25 °C	–	–	60	Ω
C _{osc}	capacitors at pins XTALIN and XTALOUT	T _{amb} = 25 °C	–	note 4	–	pF
C _O	crystal holder capacitance	T _{amb} = 25 °C	–	note 4	–	pF
T _{xtal}	crystal temperature range		–20	+25	+85	°C
X _j	adjustment tolerance	T _{amb} = 25 °C	–	–	±50 × 10 ^{–6}	
X _d	drift		–	–	±100 × 10 ^{–6}	
I²C-bus characteristics for fast mode						
f _{SCL}	SCL clock frequency		0	–	400	kHz
t _{BUF}	bus free time between a STOP and START condition		1.3	–	–	μs
t _{HD;STA}	hold time START condition; after this period; the first clock pulse is generated		0.6	–	–	μs
t _{LOW}	SCL LOW time		1.3	–	–	μs
t _{HIGH}	SCL HIGH time		0.6	–	–	μs
t _{SU;STA}	set-up time repeated START		0.6	–	–	μs
t _{HD;DAT}	data hold time	notes 5 and 6	0	–	0.9	μs
t _{SU;DAT}	data set-up time	note 7	100	–	–	ns
t _r	rise time SDA and SCL	note 7	20	–	300	ns
t _f	fall time SDA and SCL	note 7	20	–	300	ns
t _{SU;STO}	set-up time STOP condition		0.6	–	–	μs
C _b	capacitive load of each bus line	note 8	–	–	400	pF

Multi page intelligent teletext decoder

SAA5360; SAA5361

Notes

1. Periphery current is dependent on external components and voltage levels on I/Os.
2. V_{TN} is the drop across a protection transistor which clamps the input to V_{DD} . The maximum value is $V_{TN} = 0.75 V$
3. Crystal order number 4322 143 05561.
4. If the 4322 143 05561 crystal is not used, the formula in the crystal specification should be used. The mean of the capacitances due to the chip at XTALIN and at XTALOUT is C_{IO} , where $C_{IO} = 7 pF$. C_{ext} is a value for the mean of the stray capacitances due to the external circuits at XTALIN and XTALOUT.
 - a) $C_{osc(typ)} = 2C_L - C_{IO} - C_{ext}$. Capacitor C_{osc} may need to be reduced from the initial selected value.
 - b) $C_{O(max)} = 35 - 0.5 (C_{osc} + C_{IO} + C_{ext}) pF$. The maximum value for the crystal holder capacitance is to ensure start-up.
5. A device must internally provide a hold time of at least 300 ns for the SDA signal, referenced to the $V_{IH(min)}$ of the SCL signal, in order to bridge the undefined region of the falling edge of SCL.
6. The maximum $t_{HD, DAT}$ has only to be met if the device does not stretch the LOW period of the SCL signal ($t_{LOW(SCL)}$).
7. A fast mode I²C-bus device can be used in a standard-mode I²C-bus system, but the requirement $t_{SU, DAT} \geq 250 ns$ must be met. This requirement is met for a device that does not stretch $t_{LOW(SCL)}$. If a device does stretch $t_{LOW(SCL)}$, the next data bit to the SDA line must be output $t_{r(max)} + t_{SU, DAT} = 1000 + 250 = 1250 ns$ before the SCL line is released (according to the standard-mode I²C-bus specification).
8. C_b = total capacitance of one bus line in pF.

12 APPLICATION INFORMATION**12.1 EMC guidelines**

Optimization of circuit return paths and minimization of common mode emission is achieved by a double sided Printed-Circuit Board (PCB) with low inductance ground plane.

On a single-sided PCB a local ground plane under the whole IC should be present. Preferably, the PCB local ground plane connection should not be connected to other grounds on route to the PCB ground. Do not use wire links. Wire links cause ground inductance which increases ground bounce.

The supply pins can be decoupled at the ground pin plane below the IC. This is easily achieved by using surface mount capacitors, which, at high frequency, are more effective than components with leads.

Using a device socket would increase the area and therefore increase the inductance of the external bypass loop.

To provide a high-impedance to any high frequency signals on the V_{DD} supplies to the IC, a ferrite bead or inductor can be connected in series with the supply line close to the decoupling capacitor. To prevent signal radiation, pull-up resistors of signal outputs should not be connected to the V_{DD} supply on the IC side of the ferrite bead or inductor.

OSCGND should only be connected to the crystal load capacitors and not to any other ground connection.

Distances to physical connections of associated active devices should be as short as possible.

PCB output tracks should have close proximity, mutually coupled and ground return paths.

Multi page intelligent teletext decoder

SAA5360; SAA5361

12.2 Application diagram

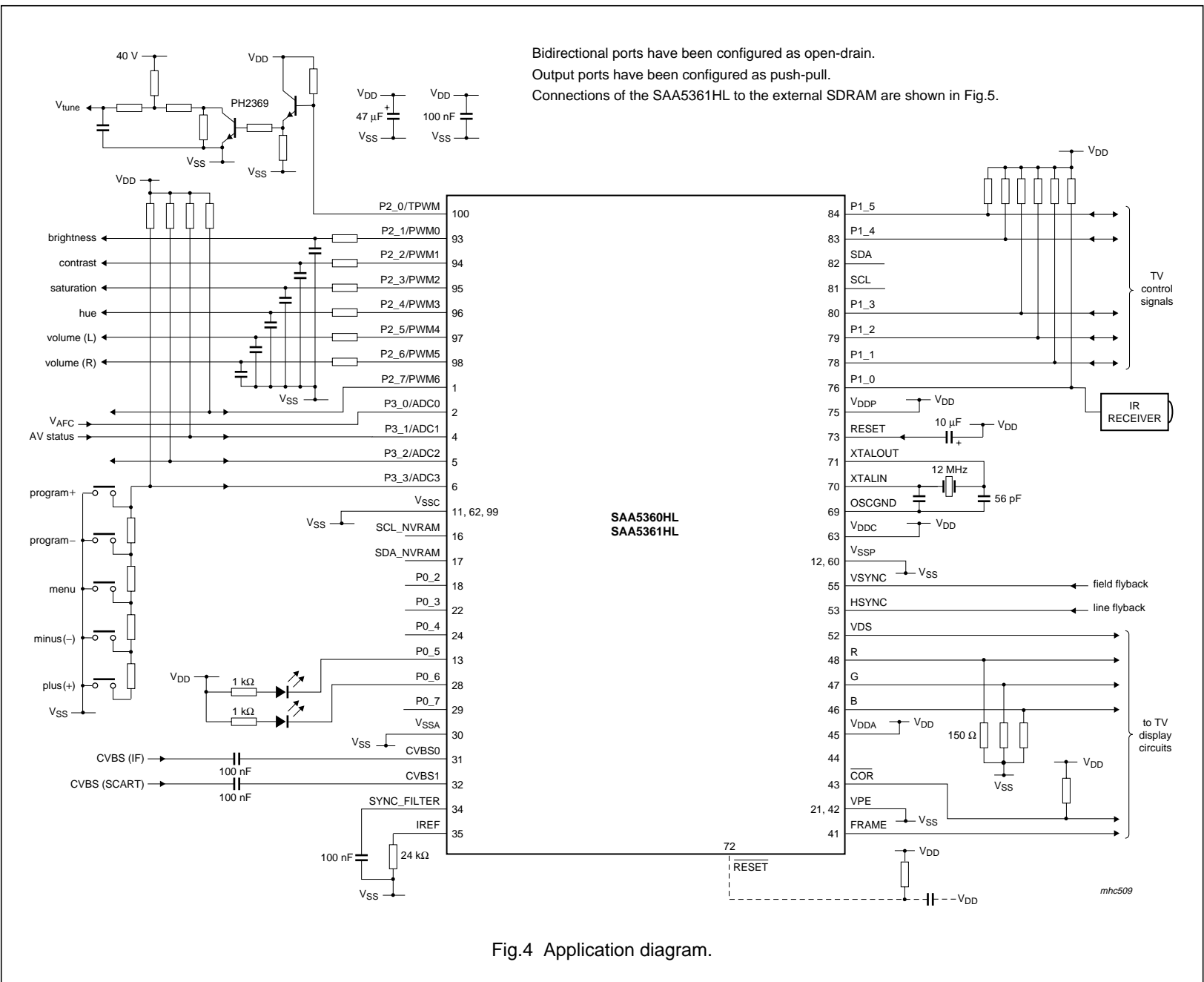
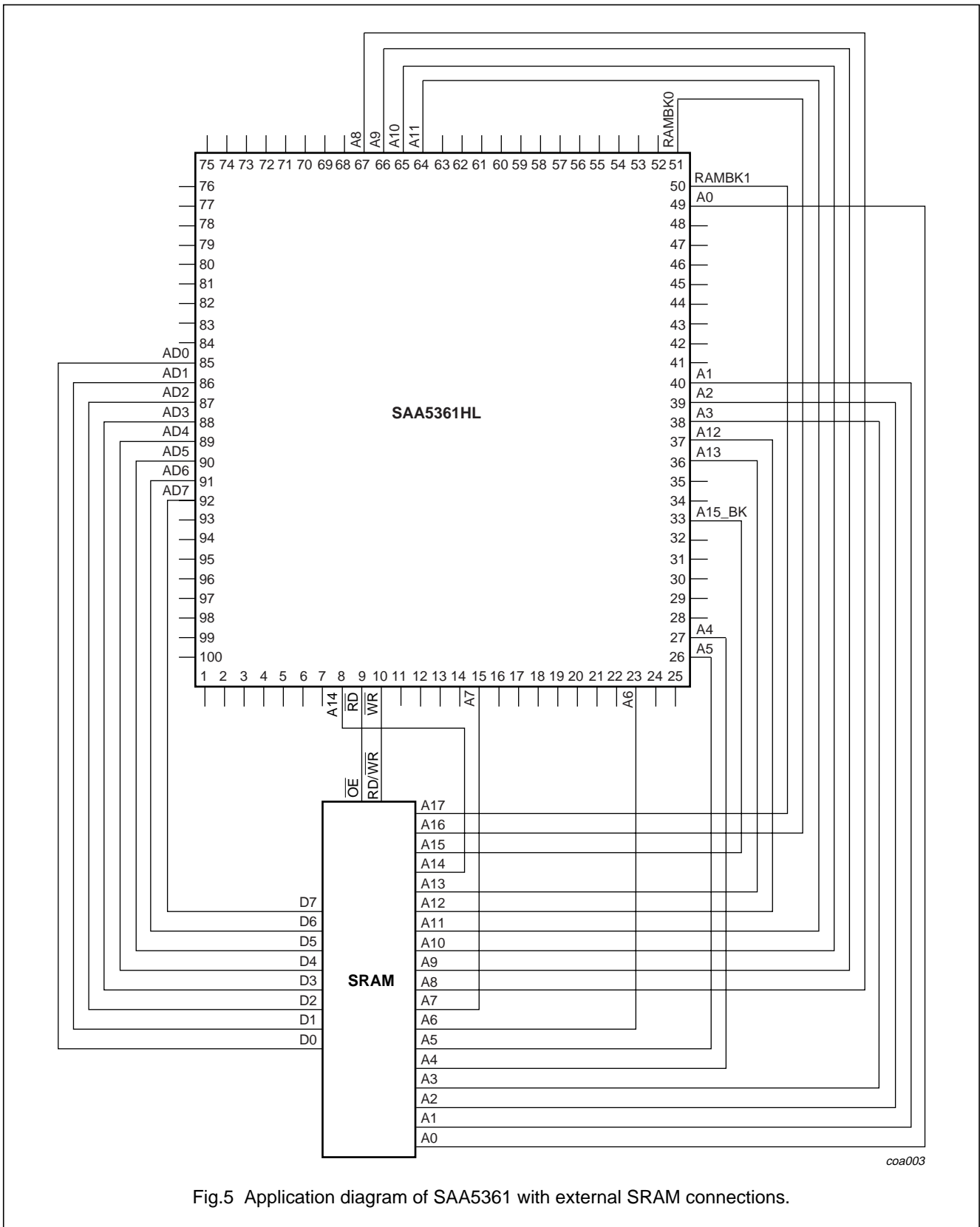

Fig.4 Application diagram.

Multi page intelligent teletext decoder

SAA5360; SAA5361



coa003

Fig.5 Application diagram of SAA5361 with external SRAM connections.

Multi page intelligent teletext decoder

SAA5360; SAA5361

12.3 Application notes

Ports AD0 to AD7 of the microcontroller can be connected to pins D0 to D7 of the SRAM in any order.

For the addressing, the lower group of address lines (A0 to A8) and the upper group of address lines (A9 to A14, A15_BK, RAMBK0 and RAMBK1) may be connected in any order within the groups, provided that the full 256 kbytes of external SRAM is used.

Fig.5 shows the application diagram of the SAA5361 with external SRAM connections.

When using an external SRAM smaller than 256 kbytes, the relevant number of bits from the microcontroller address bus should be disconnected, always removing the most significant bits first.

For power saving modes, it might be advisable to control the CE pin of the SRAM module(s) using one of the microcontroller ports to de-select the SRAM.

12.3.1 EXTERNAL DATA MEMORY ACCESS

Table 4 External data memory access (see Fig.6 and Fig.7)

SYMBOL	PARAMETER	TYPICAL ⁽¹⁾	UNIT
t _{RLRH}	\overline{RD} pulse width	250	ns
t _{WLWH}	\overline{WR} pulse width	250	ns
t _{RLDV}	\overline{RD} LOW to valid data in	198	ns
t _{RHDx}	Data hold after \overline{RD}	0	ns
t _{RHDz}	Data float after \overline{RD}	tbd	ns
t _{LLWL}	ALE LOW to \overline{RD} or \overline{WR} LOW	132	ns
t _{AVWL}	Address valid to \overline{WR} LOW or \overline{RD} LOW	172	ns
t _{QVWX}	Data valid to \overline{WR} LOW	89	ns
t _{WHQX}	Data hold after \overline{WR}	15	ns
t _{RLAZ}	\overline{RD} LOW to address float	tbd	ns
t _{WHLH}	\overline{RD} or \overline{WR} HIGH to ALE HIGH	40	ns

Note

1. The timings are only valid for the nominal 12 MHz clock provided to the microcontroller.

12.3.2 SYMBOL EXPLANATIONS

Each timing symbol has five characters. The first character is always 't' (time). Depending on their positions, the other characters indicate the name of a signal or the logical status of that signal.

The designations are:

- A = Address
- C = Clock
- D = Input data
- H = Logic level HIGH
- I = Instruction (program memory contents)
- L = Logic level LOW, or ALE
- P = PSEN
- Q = Output data
- R = RD signal
- t = Time
- V = Valid
- W = WR signal
- X = No longer a valid logic level
- Z = Float

Examples:

t_{AVLL} = time for address valid to ALE LOW.

t_{LLPL} = time for ALE to PSEN LOW.

Multi page intelligent teletext decoder

SAA5360; SAA5361

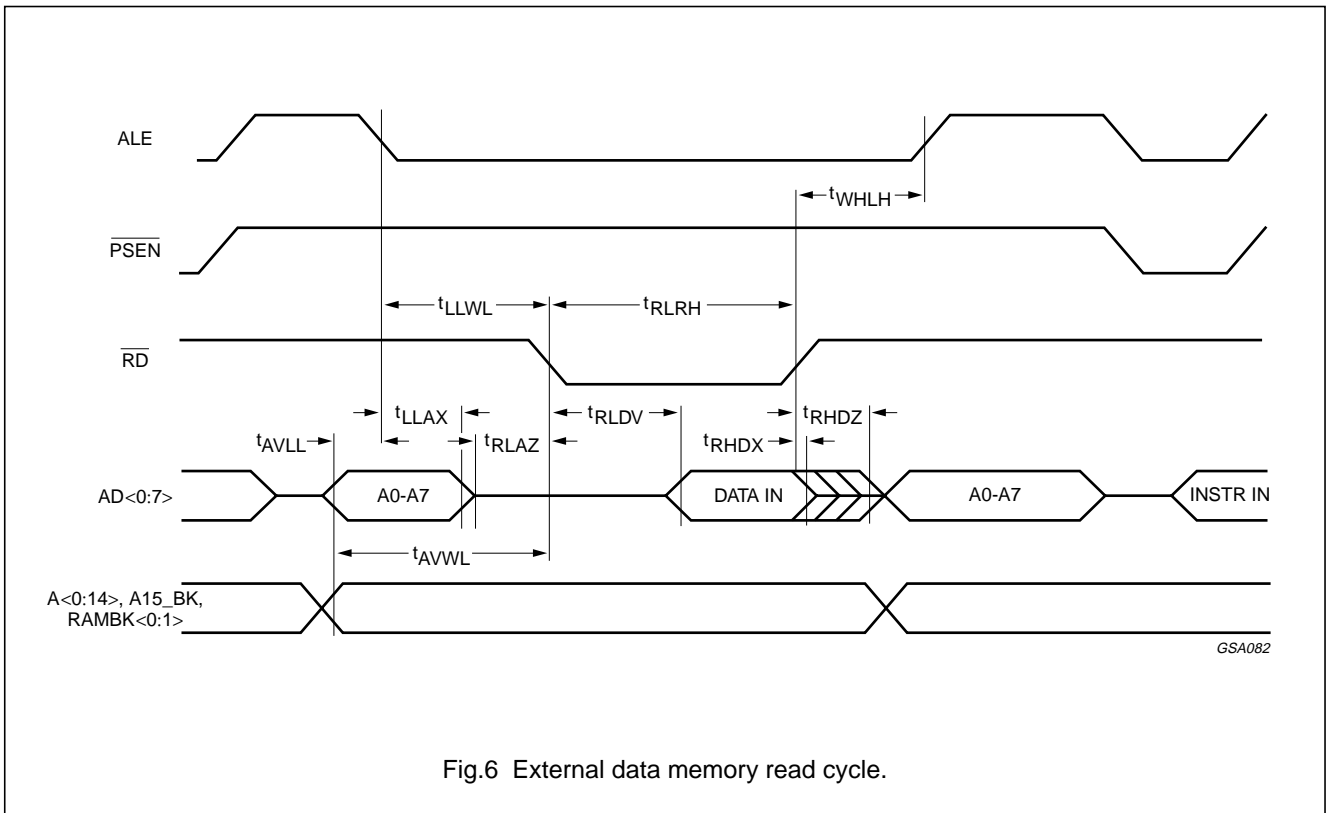

Fig.6 External data memory read cycle.

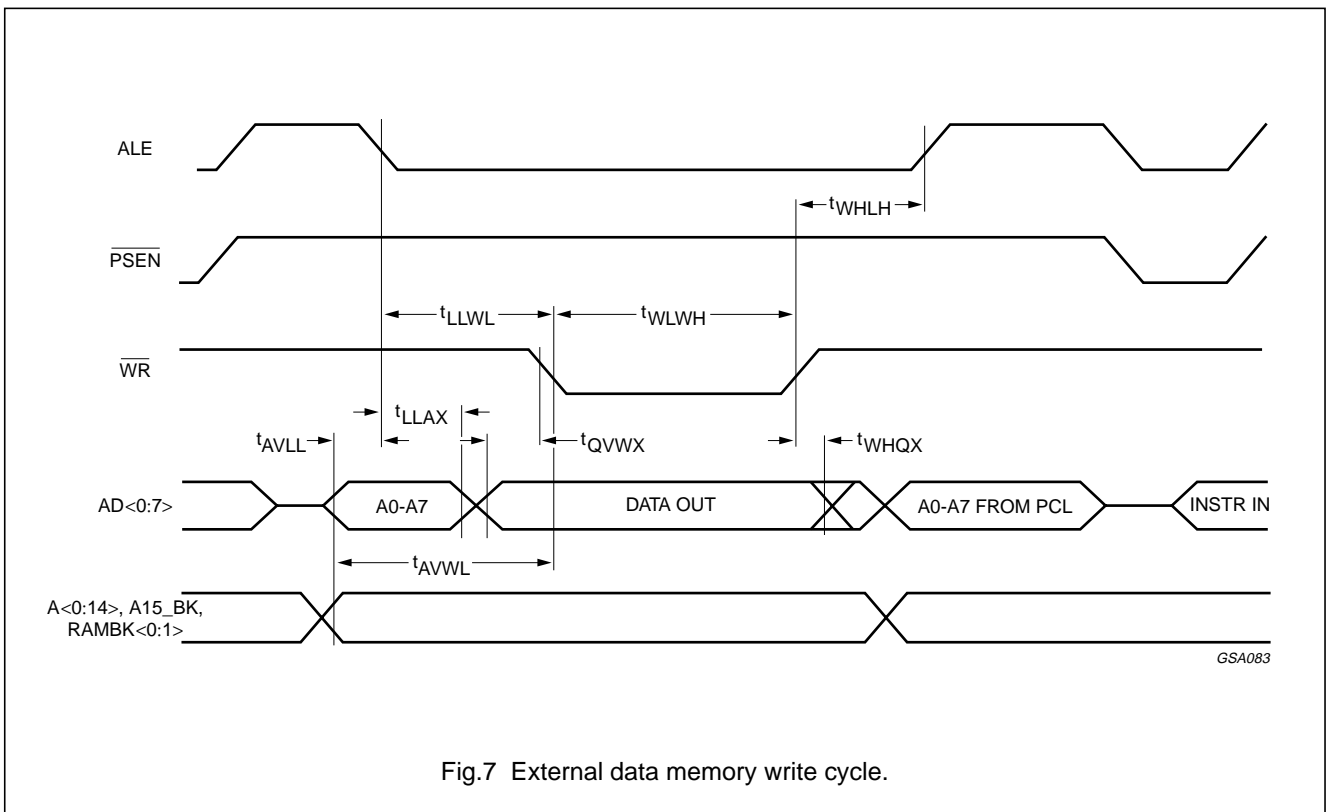

Fig.7 External data memory write cycle.

Multi page intelligent teletext decoder

SAA5360; SAA5361

13 PACKAGE OUTLINE

LQFP100: plastic low profile quad flat package; 100 leads; body 14 x 14 x 1.4 mm

SOT407-1

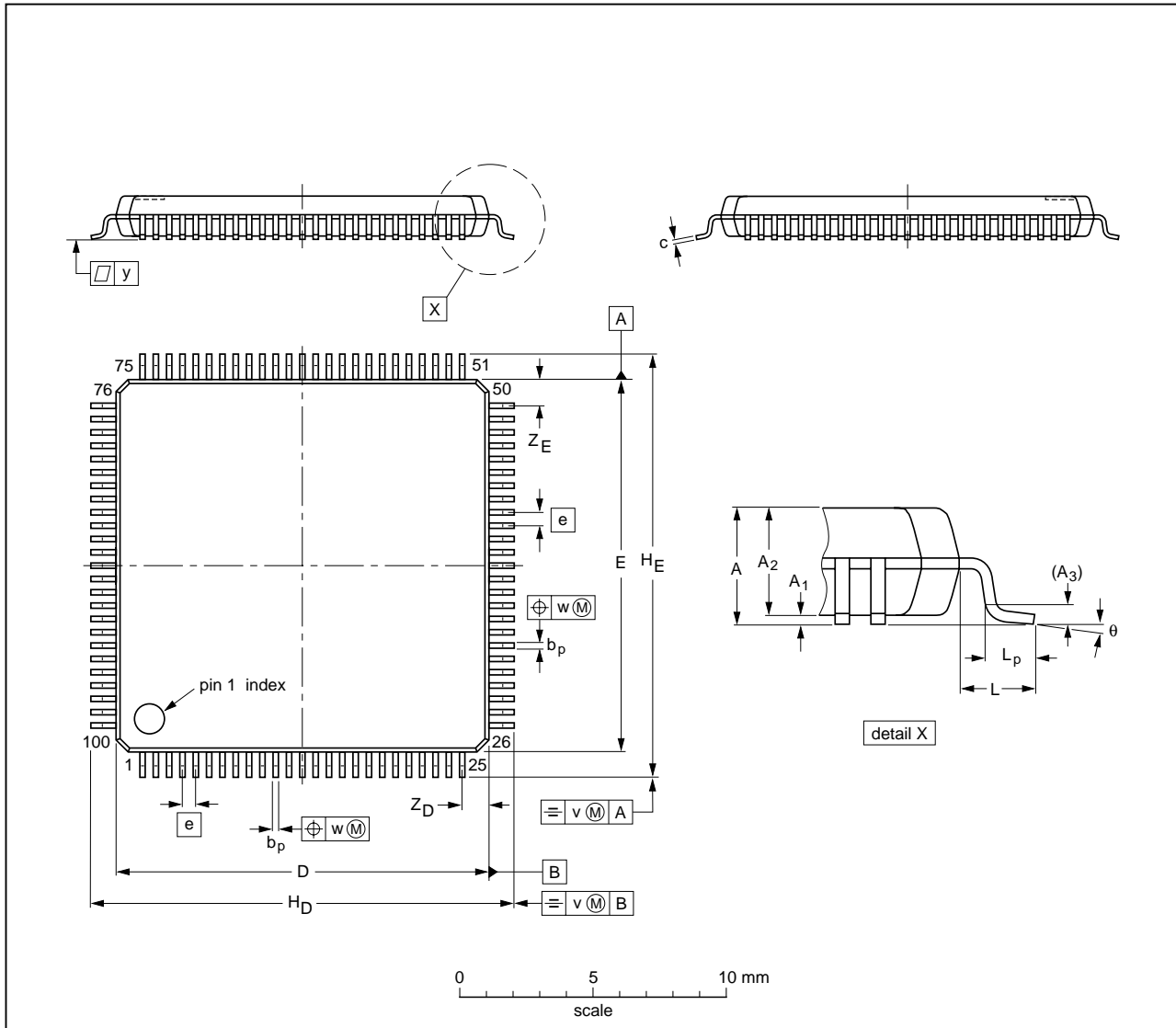

DIMENSIONS (mm are the original dimensions)

UNIT	A max.	A ₁	A ₂	A ₃	b _p	c	D ⁽¹⁾	E ⁽¹⁾	e	H _D	H _E	L	L _p	v	w	y	Z _D ⁽¹⁾	Z _E ⁽¹⁾	θ
mm	1.6	0.15 0.05	1.45 1.35	0.25	0.27 0.17	0.20 0.09	14.1 13.9	14.1 13.9	0.5	16.25 15.75	16.25 15.75	1	0.75 0.45	0.2	0.08	0.08	1.15 0.85	1.15 0.85	7° 0°

Note
1. Plastic or metal protrusions of 0.25 mm maximum per side are not included.

OUTLINE VERSION	REFERENCES				EUROPEAN PROJECTION	ISSUE DATE
	IEC	JEDEC	JEITA			
SOT407-1	136E20	MS-026				00-02-01 03-02-20

Multi page intelligent teletext decoder

SAA5360; SAA5361

14 SOLDERING

14.1 Introduction to soldering surface mount packages

This text gives a very brief insight to a complex technology. A more in-depth account of soldering ICs can be found in our *"Data Handbook IC26; Integrated Circuit Packages"* (document order number 9398 652 90011).

There is no soldering method that is ideal for all surface mount IC packages. Wave soldering can still be used for certain surface mount ICs, but it is not suitable for fine pitch SMDs. In these situations reflow soldering is recommended.

14.2 Reflow soldering

Reflow soldering requires solder paste (a suspension of fine solder particles, flux and binding agent) to be applied to the printed-circuit board by screen printing, stencilling or pressure-syringe dispensing before package placement. Driven by legislation and environmental forces the worldwide use of lead-free solder pastes is increasing.

Several methods exist for reflowing; for example, convection or convection/infrared heating in a conveyor type oven. Throughput times (preheating, soldering and cooling) vary between 100 seconds and 200 seconds depending on heating method.

Typical reflow peak temperatures range from 215 °C to 270 °C depending on solder paste material. The top-surface temperature of the packages should preferably be kept:

- below 225 °C (SnPb process) or below 245 °C (Pb-free process)
 - for all BGA, HTSSON..T and SSOP..T packages
 - for packages with a thickness ≥ 2.5 mm
 - for packages with a thickness < 2.5 mm and a volume ≥ 350 mm³ so called thick/large packages.
- below 240 °C (SnPb process) or below 260 °C (Pb-free process) for packages with a thickness < 2.5 mm and a volume < 350 mm³ so called small/thin packages.

Moisture sensitivity precautions, as indicated on packing, must be respected at all times.

14.3 Wave soldering

Conventional single wave soldering is not recommended for surface mount devices (SMDs) or printed-circuit boards with a high component density, as solder bridging and non-wetting can present major problems.

To overcome these problems the double-wave soldering method was specifically developed.

If wave soldering is used the following conditions must be observed for optimal results:

- Use a double-wave soldering method comprising a turbulent wave with high upward pressure followed by a smooth laminar wave.
- For packages with leads on two sides and a pitch (e):
 - larger than or equal to 1.27 mm, the footprint longitudinal axis is **preferred** to be parallel to the transport direction of the printed-circuit board;
 - smaller than 1.27 mm, the footprint longitudinal axis **must** be parallel to the transport direction of the printed-circuit board.

The footprint must incorporate solder thieves at the downstream end.

- For packages with leads on four sides, the footprint must be placed at a 45° angle to the transport direction of the printed-circuit board. The footprint must incorporate solder thieves downstream and at the side corners.

During placement and before soldering, the package must be fixed with a droplet of adhesive. The adhesive can be applied by screen printing, pin transfer or syringe dispensing. The package can be soldered after the adhesive is cured.

Typical dwell time of the leads in the wave ranges from 3 seconds to 4 seconds at 250 °C or 265 °C, depending on solder material applied, SnPb or Pb-free respectively.

A mildly-activated flux will eliminate the need for removal of corrosive residues in most applications.

14.4 Manual soldering

Fix the component by first soldering two diagonally-opposite end leads. Use a low voltage (24 V or less) soldering iron applied to the flat part of the lead. Contact time must be limited to 10 seconds at up to 300 °C.

When using a dedicated tool, all other leads can be soldered in one operation within 2 seconds to 5 seconds between 270 °C and 320 °C.

Multi page intelligent teletext decoder

SAA5360; SAA5361

14.5 Suitability of surface mount IC packages for wave and reflow soldering methods

PACKAGE ⁽¹⁾	SOLDERING METHOD	
	WAVE	REFLOW ⁽²⁾
BGA, HTSSON..T ⁽³⁾ , LBGA, LFBGA, SQFP, SSOP..T ⁽³⁾ , TFBGA, VFBGA, XSON	not suitable	suitable
DHVQFN, HBCC, HBGA, HLQFP, HSO, HSOP, HSQFP, HSSON, HTQFP, HTSSOP, HVQFN, HVSON, SMS	not suitable ⁽⁴⁾	suitable
PLCC ⁽⁵⁾ , SO, SOJ	suitable	suitable
LQFP, QFP, TQFP	not recommended ⁽⁵⁾⁽⁶⁾	suitable
SSOP, TSSOP, VSO, VSSOP	not recommended ⁽⁷⁾	suitable
CWQCCN..L ⁽⁸⁾ , PMFP ⁽⁹⁾ , WQCCN..L ⁽⁸⁾	not suitable	not suitable

Notes

- For more detailed information on the BGA packages refer to the “(LF)BGA Application Note” (AN01026); order a copy from your Philips Semiconductors sales office.
- All surface mount (SMD) packages are moisture sensitive. Depending upon the moisture content, the maximum temperature (with respect to time) and body size of the package, there is a risk that internal or external package cracks may occur due to vaporization of the moisture in them (the so called popcorn effect). For details, refer to the Drypack information in the “Data Handbook IC26; Integrated Circuit Packages; Section: Packing Methods”.
- These transparent plastic packages are extremely sensitive to reflow soldering conditions and must on no account be processed through more than one soldering cycle or subjected to infrared reflow soldering with peak temperature exceeding $217\text{ °C} \pm 10\text{ °C}$ measured in the atmosphere of the reflow oven. The package body peak temperature must be kept as low as possible.
- These packages are not suitable for wave soldering. On versions with the heatsink on the bottom side, the solder cannot penetrate between the printed-circuit board and the heatsink. On versions with the heatsink on the top side, the solder might be deposited on the heatsink surface.
- If wave soldering is considered, then the package must be placed at a 45° angle to the solder wave direction. The package footprint must incorporate solder thieves downstream and at the side corners.
- Wave soldering is suitable for LQFP, QFP and TQFP packages with a pitch (e) larger than 0.8 mm; it is definitely not suitable for packages with a pitch (e) equal to or smaller than 0.65 mm.
- Wave soldering is suitable for SSOP, TSSOP, VSO and VSSOP packages with a pitch (e) equal to or larger than 0.65 mm; it is definitely not suitable for packages with a pitch (e) equal to or smaller than 0.5 mm.
- Image sensor packages in principle should not be soldered. They are mounted in sockets or delivered pre-mounted on flex foil. However, the image sensor package can be mounted by the client on a flex foil by using a hot bar soldering process. The appropriate soldering profile can be provided on request.
- Hot bar soldering or manual soldering is suitable for PMFP packages.

Multi page intelligent teletext decoder

SAA5360; SAA5361

15 DATA SHEET STATUS

LEVEL	DATA SHEET STATUS ⁽¹⁾	PRODUCT STATUS ⁽²⁾⁽³⁾	DEFINITION
I	Objective data	Development	This data sheet contains data from the objective specification for product development. Philips Semiconductors reserves the right to change the specification in any manner without notice.
II	Preliminary data	Qualification	This data sheet contains data from the preliminary specification. Supplementary data will be published at a later date. Philips Semiconductors reserves the right to change the specification without notice, in order to improve the design and supply the best possible product.
III	Product data	Production	This data sheet contains data from the product specification. Philips Semiconductors reserves the right to make changes at any time in order to improve the design, manufacturing and supply. Relevant changes will be communicated via a Customer Product/Process Change Notification (CPCN).

Notes

1. Please consult the most recently issued data sheet before initiating or completing a design.
2. The product status of the device(s) described in this data sheet may have changed since this data sheet was published. The latest information is available on the Internet at URL <http://www.semiconductors.philips.com>.
3. For data sheets describing multiple type numbers, the highest-level product status determines the data sheet status.

16 DEFINITIONS

Short-form specification — The data in a short-form specification is extracted from a full data sheet with the same type number and title. For detailed information see the relevant data sheet or data handbook.

Limiting values definition — Limiting values given are in accordance with the Absolute Maximum Rating System (IEC 60134). Stress above one or more of the limiting values may cause permanent damage to the device. These are stress ratings only and operation of the device at these or at any other conditions above those given in the Characteristics sections of the specification is not implied. Exposure to limiting values for extended periods may affect device reliability.

Application information — Applications that are described herein for any of these products are for illustrative purposes only. Philips Semiconductors make no representation or warranty that such applications will be suitable for the specified use without further testing or modification.

17 DISCLAIMERS

Life support applications — These products are not designed for use in life support appliances, devices, or systems where malfunction of these products can reasonably be expected to result in personal injury. Philips Semiconductors customers using or selling these products for use in such applications do so at their own risk and agree to fully indemnify Philips Semiconductors for any damages resulting from such application.

Right to make changes — Philips Semiconductors reserves the right to make changes in the products - including circuits, standard cells, and/or software - described or contained herein in order to improve design and/or performance. When the product is in full production (status 'Production'), relevant changes will be communicated via a Customer Product/Process Change Notification (CPCN). Philips Semiconductors assumes no responsibility or liability for the use of any of these products, conveys no licence or title under any patent, copyright, or mask work right to these products, and makes no representations or warranties that these products are free from patent, copyright, or mask work right infringement, unless otherwise specified.

Philips Semiconductors – a worldwide company

Contact information

For additional information please visit <http://www.semiconductors.philips.com>. Fax: +31 40 27 24825

For sales offices addresses send e-mail to: sales.addresses@www.semiconductors.philips.com.

© Koninklijke Philips Electronics N.V. 2005

SCA76

All rights are reserved. Reproduction in whole or in part is prohibited without the prior written consent of the copyright owner.

The information presented in this document does not form part of any quotation or contract, is believed to be accurate and reliable and may be changed without notice. No liability will be accepted by the publisher for any consequence of its use. Publication thereof does not convey nor imply any license under patent- or other industrial or intellectual property rights.

Printed in The Netherlands

R24/06/pp28

Date of release: 2005 Mar 09

Document order number: 9397 750 14857

Let's make things better.

**Philips
Semiconductors**



PHILIPS