



### SOT-25



### Pin Definition:

1. SW
2. Ground
3. Feedback
4. CTRL
5. Input

## General Description

The TS1937 is a step-up DC/DC converter specifically designed to drive white LEDs with a constant current. The device can drive 2 ~ 12 LEDs in series from a Li-Ion cell. Series connection of the LEDs provides identical LED currents resulting in uniform brightness and eliminating the need for ballast resistors. The output capacitor can be as small as 0.22 $\mu$ F, saving space versus alternative solutions. A low 95mV feedback voltage minimizes power loss for better efficiency. Additional features include over output voltage limiting when LEDs are disconnected.

The TS1937 switches at a fixed frequency of 1.2MHz, allowing the use of tiny, low profile inductors and capacitors to minimize footprint and cost in space consideration applications for cellular phone backlighting or other hand held equipment.

## Features

- Inherently Matched LED Current
- High Efficiency: 88% Typical
- Drives Up to 6 LEDs @ Vin 5V
- Drives Up to 12 LEDs @ Vin 12~15V
- 36V Rugged Bipolar Switch
- Fast 1.2MHz Switching Frequency
- Requires Only 0.22 $\mu$ F Output Capacitor
- PWM dimming control 1KHz to 10KHz
- Analog dimming control

## Application

- Cellular Phones
- Digital Still Cameras
- MP3 Players
- White LED Backlighting
- PDAs, Handheld computers

## Ordering Information

Part No.	Package	Packing
TS1937CX5 RF	SOT-25	3Kpcs / 7" Reel

## Typical Application Circuit

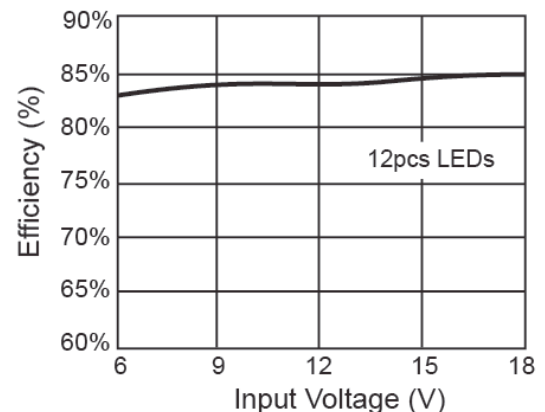
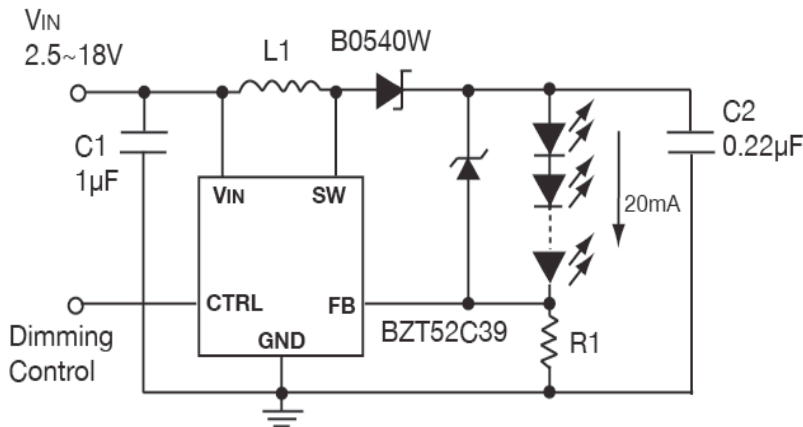

### Absolute Maximum Rating

Parameter	Symbol	Limit	Unit
Input Voltage	$V_{IN}$	20	V
Supply Voltage (Recommended)	$V_{IN}$	2.5 ~ 18	V
FB Voltage	$V_{FB}$	10	V
SW Voltage	$V_{SW}$	36	V
CTRL Voltage	$V_{CTRL}$	10	V
Ambient Temperature Range	$T_A$	-40 to +85	°C
Junction Temperature Range	$T_J$	-40 to +125	°C

### Electrical Specifications ( $T_a = 25^\circ\text{C}$ , $V_{IN} = V_{CTRL} = 3\text{V}$ , $C_{IN} = 1\mu\text{F}$ , $C_{OUT} = 0.22\mu\text{F}$ unless otherwise noted)

Function Parameter	Symbol	Test Conditions	Min	Typ	Max	Units
Input Voltage Range	$V_{IN}$		2.5	--	18	V
Feedback Voltage	$V_{FB}$	Isw=100mA, 66% duty cycle	86	95	104	mV
FB Pin Bias Current	$I_B$		10	45	100	nA
Supply Current	$I_Q$		--	1.9	2.5	mA
		CTRL = 0V	--	0.1	1.0	uA
Switching Frequency	$F_{RSW}$		0.8	1.2	1.6	MHz
Switch Current Limit	$I_{CL}$		--	320	--	mA
Maximum Duty Cycle	$D_{TMX}$		85	90	--	%
Switch Vcesat	$V_{SAT}$	At Isw = 250mA	--	350	--	mV
Switch Leakage Current	$I_{LKG}$	Vsw = 5V	--	0.01	5	μA
Voltage Enable Control	$V_{CTRL}$	High	1.5	--	--	V
		Low	--	--	0.4	V
CTRL Pin Bias Current	$I_{CTRL}$	Ctrl = 2V	--	65	--	μA
Thermal Resistance	$\theta_{JA}$		--	220	--	°C/W

Note:

Absolute maximum ratings are limits beyond which damage to the device may occur.

The maximum allowable power dissipation is a function of maximum junction temperature,  $T_{J(max)}$ , the junction to ambient thermal resistance,  $\theta_{JA}$ , and the ambient temperature. The maximum allowable power dissipation at any ambient temperature is calculated using:  $P_{D(MAX)} = [T_{J(max)} - T_A] / \theta_{JA}$ . Exceeding the maximum allowable power dissipation will cause excessive die temperature. All limits at temperature extremes are guaranteed via correlation using standard statistical methods

**Functional Block**

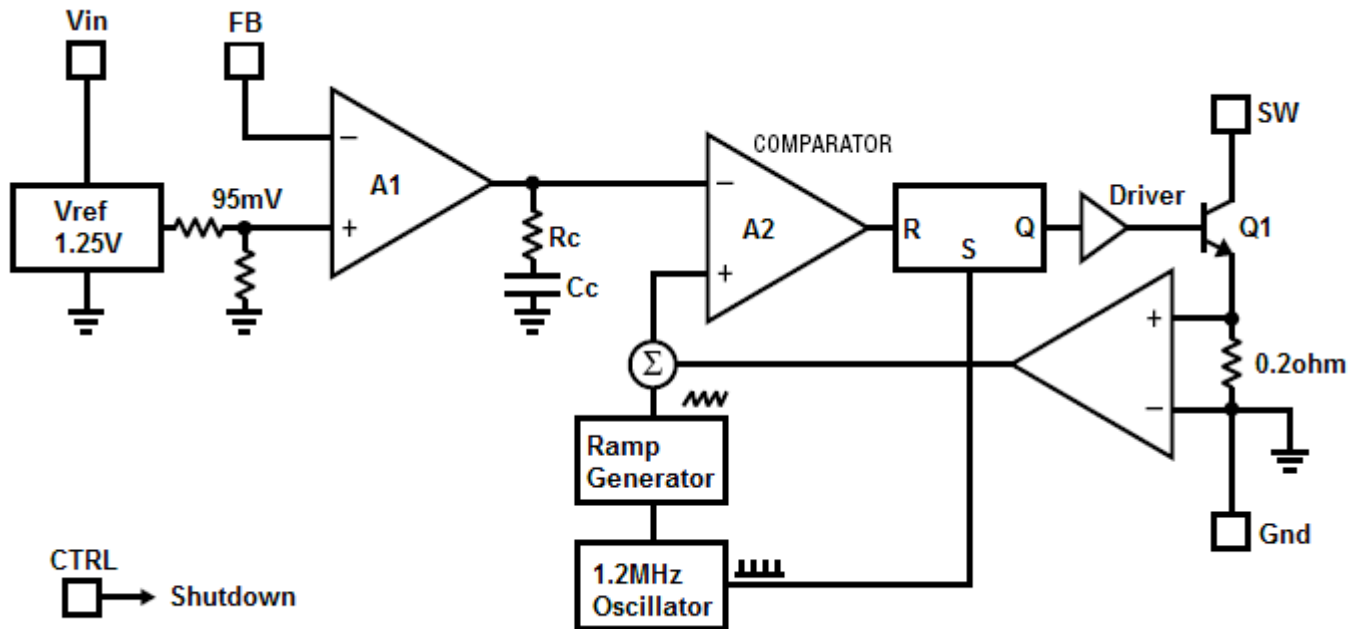

**Pin Description**

Pin	Function	Description
1	SW	Switching Pin. This is the collector of the internal NPN power switch. Connect to inductor and diode. Minimize the metal trace area connected to this pin to reduce EMI.
2	Ground	Ground Pin. Connect directly to local ground plane.
3	Feedback	Feedback Pin. Reference voltage is 95mV. Connect LEDs and a resistor at this pin. LED current is determined by the resistance and CTRL voltage.
4	CTRL	Shutdown Pin and Dimming Control Pin. VCTRL > 1.8V generates full-scale LED current VCTRL < 0.4V chip is off Switching from 0.4V to 2.0V, PWM duty cycle controls the LED current
5	Input	Input Supply Pin. Bypass this pin with a capacitor as close to the device as possible

### Application Information

#### Operation

The TS1937 uses a constant frequency, current mode control scheme to provide excellent line and load regulation. Operation can be best understood by referring to the block diagram. At the start of each oscillator cycle, the RS latch is set, which turns on the power switch Q1. A voltage proportional to the switch current is added to a stabilizing ramp and the resulting sum is fed into the positive terminal of the PWM comparator A2. When this voltage exceeds the level at the negative input of A2, the RS latch is reset turning off the power switch. The level at the negative input of A2 is set by the error amplifier A1, and is simply an amplified version of the difference between the feedback voltage and the reference voltage of 95mV. In this manner, the error amplifier sets the correct peak current level to keep the output in regulation. If the error amplifier's output increases, more current is delivered to the output; if it decreases, less current is delivered.

#### Minimum Output Current

The TS1937 can regulate three series LEDs connected at low output currents, down to approximately 4mA from a 4.2V supply, without pulse skipping, using the same external components as specified for 20mA operation. As the current is further reduced, the device will begin skipping pulses. This will result in some low frequency ripple, although the LED current remains regulated on an average basis down to zero.

#### Soft Start and Current Limit

The internal soft start circuit minimizes the inrush current during turning on TS1937. The Typical switch current is limited to about 320mA by the chip.

#### Over Voltage Protection

The TS1937 has design an internal latched off open-circuit protection circuit, the additional sense pin to detect the voltage when the LEDs are disconnected from the circuit or fail open, the TS1937 will shutdown until input condition changes to bring it out of the shutdown mode.

#### Inductor Selection

A 22mH inductor is recommended for most TS1937 applications. Although small size and high efficiency are major concerns, the inductor should have low core losses at 1.2MHz and low DCR (copper wire resistance).

#### Diode Selection

To maintain high efficiency, the average current rating of the Schottky diode should be large than the peak inductor current, IPK. Schottky diode with a low forward drop and fast switching speeds are ideal for increase efficiency in portable application. Choose a reverse breakdown of the Schottky diode large than the output voltage. A Schottky diode rated at 100mA to 200mA is sufficient for most TS1937 applications.

#### Capacitor Selection

The small size of ceramic capacitors makes them ideal for TS1937 applications. X5R and X7R types are recommended because they retain their capacitance over wider voltage and temperature ranges than other types such as Y5V or Z5U. A 1 $\mu$ F input capacitor and a 0.22 $\mu$ F output capacitor are sufficient for most.

**Application Information (Continue)**

**Reference Design Information**

VIN Range (V)	VOUT Max. (V)	L (uH)	LED (Series)	Current (mA)	Resistor (Ω)	Efficiency (%)
5	36	22	6pcs	20	4.75	83.5
9	36	33	11pcs	20	4.75	84.2
12	36	47	12pcs	20	4.75	84.3
15	36	68	12pcs	20	4.75	84.6

**LED Dimming Control**

There are some different types of dimming control circuits:

1. Using a PWM Signal to SHDN Pin

With the PWM signal applied to the SHDN pin, the TS1937 is turned on or off by the PWM signal. The LEDs operate at either zero or full current. The average LED current increases proportionally with the duty cycle of the PWM signal. A 0% duty cycle will turn off the TS1937 and corresponds to zero LED current. A 100% duty cycle corresponds to full current. The typical frequency range of the PWM signal is 1kHz to 10kHz.

The magnitude of the PWM signal should be higher than the minimum SHDN voltage high.

For some applications, the preferred method of brightness control is a variable DC voltage to adjust the LED current. The dimming control using a DC voltage is shown in Figure 4. As the DC voltage increases, the voltage drop on R2 increases and the voltage drop on R1 decreases. Thus, the LED current decreases. The selection of R2 and R3 will make the current from the variable DC source much smaller than the LED current and much larger than the FB pin bias current. For VDC range from 0V to 2V, the selection of resistors in Figure 4 gives dimming control of LED current from 0mA to 20mA.

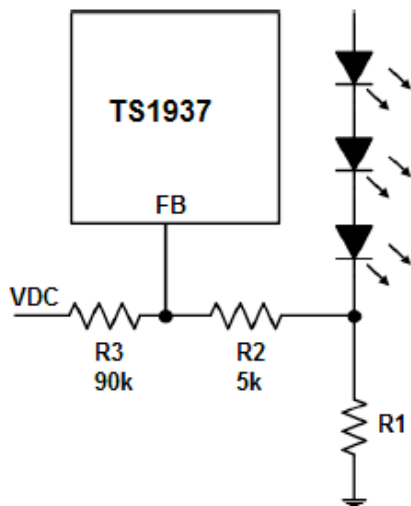

VDC(V)	VFB	Iout(mA)
2	0	0
1.8	2.2	0.43
1.6	9.2	1.8
1.4	19.6	3.6
1.2	31.1	6
1	43.4	8.5
0.8	63	12.3
0.6	74	14.5
0.4	86.4	16.9
0.2	96.9	19
0	102	20

**Dimming Control using a DC Voltage**

**Application Information (Continue)**

**2. Using a Filtered PWM Signal**

The filtered PWM signal can be considered as an adjustable DC voltage. It can be used to replace the variable DC voltage source in dimming control. The circuit is shown as follow:

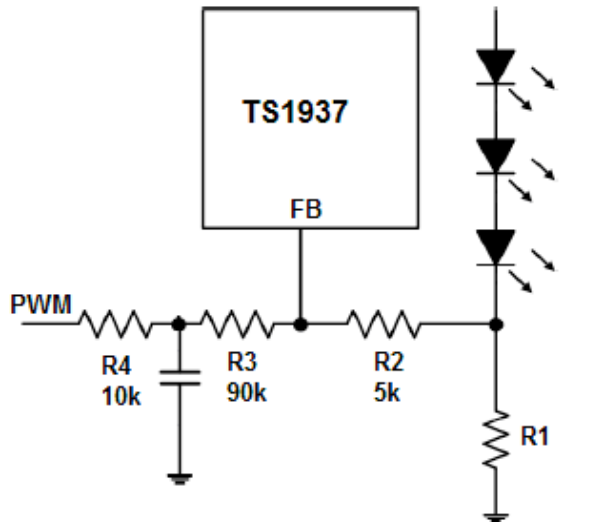

Duty	Iout ( mA)
0%	20
20%	17.4
30%	15
40%	12.4
50%	10
60%	8
70%	6.4
80%	4.07
100%	0

PWM : 2V ; 1KHz ; Vin=3.6V

**Dimming Control using a Filtered PWM Signal**

**LED Current Control**

The LED current is controlled by the feedback resistor (R1). The feedback reference is 95mV. The LED current is 95mV/R1. In order to have accurate LED current, precision resistors are preferred (1% is recommended). The formula and table 3 for R1 selection are shown below.

$R1 = 95mV / I_{LED}$

I <sub>LED</sub> (mA)	R1(Ω)
5	19.1
10	9.53
12	7.87
15	6.34
20	4.75

**SOT-25 Mechanical Drawing**

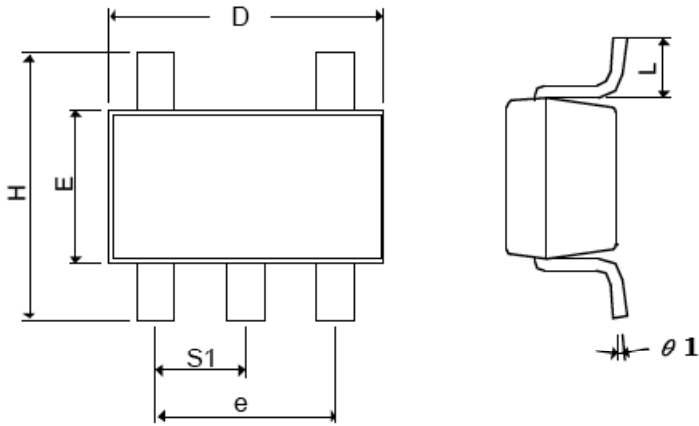

DIM	MILLIMETERS		INCHES	
	MIN	MAX	MIN	MAX.
A+A1	0.09	1.25	0.0354	0.0492
B	0.30	0.50	0.0118	0.0197
C	0.09	0.25	0.0035	0.0098
D	2.70	3.10	0.1063	0.1220
E	1.40	1.80	0.0551	0.0709
E	1.90 BSC		0.0748 BSC	
H	2.40	3.00	0.09449	0.1181
L	0.35 BSC		0.0138 BSC	
θ1	0°	10°	0°	10°
S1	0.95 BSC		0.0374 BSC	

**Front View**

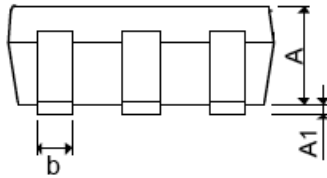

**Marking Diagram**

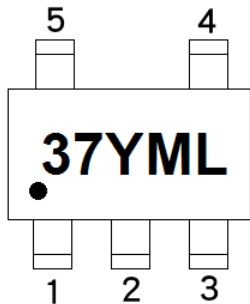

- 37** = Device Code
- Y** = Year Code
- M** = Month Code  
(A=Jan, B=Feb, C=Mar, D=Apl, E=May, F=Jun, G=Jul, H=Aug, I=Sep, J=Oct, K=Nov, L=Dec)
- L** = Lot Code

### Notice

Specifications of the products displayed herein are subject to change without notice. TSC or anyone on its behalf, assumes no responsibility or liability for any errors or inaccuracies.

Information contained herein is intended to provide a product description only. No license, express or implied, to any intellectual property rights is granted by this document. Except as provided in TSC's terms and conditions of sale for such products, TSC assumes no liability whatsoever, and disclaims any express or implied warranty, relating to sale and/or use of TSC products including liability or warranties relating to fitness for a particular purpose, merchantability, or infringement of any patent, copyright, or other intellectual property right.

The products shown herein are not designed for use in medical, life-saving, or life-sustaining applications. Customers using or selling these products for use in such applications do so at their own risk and agree to fully indemnify TSC for any damages resulting from such improper use or sale.