



INTEGRATED CIRCUIT

TECHNICAL DATA

TA7061AP

TOSHIBA BIPOLAR LINEAR INTEGRATED CIRCUIT

SILICON MONOLITHIC

FOR FM IF AMPLIFIER

FOR TV AMPLIFIER

- High Power Gain : $G_p=69\text{dB(Typ.)}$
- Good Limiter Characteristic : $V_{IN(lim)}=600\mu\text{V(Typ.)}$
- High Output Voltage : $V_{OM}=800\text{mV(Typ.)}$
- Wide Frequency Range : $f=1\text{kHz} \sim 20\text{MHz}$
- Operating Supply Voltage Range : $V_{CC}=6 \sim 15\text{V}$

MAXIMUM RATINGS ($T_a=25^\circ\text{C}$)

CHARACTERISTIC	SYMBOL	RATING	UNIT
Supply Voltage	V_{CC}	15	V
Input Voltage (Between Terminals 6 and 7)	V_{IN}	± 3	V
Power Dissipation (Note)	P_D	400	mW
Operating Temperature ($V_{CC}=7.5\text{V}$)	T_{opr}	$-25 \sim 75$	$^\circ\text{C}$
Storage Temperature	T_{stg}	$-55 \sim 125$	$^\circ\text{C}$

Note: Derated above $T_a=25^\circ\text{C}$ in the proportion of $4\text{mW}/^\circ\text{C}$.

ELECTRICAL CHARACTERISTICS ($T_a=25^\circ\text{C}$)

CHARACTERISTIC		SYMBOL	TEST CIR-CUIT	TEST CONDITION	MIN.	TYP.	MAX.	UNIT
Supply Current		I_{CC}	1	$V_{CC}=12\text{V}$	-	11	14	mA
				$V_{CC}=6\text{V}$	7.0	8.5	-	
Output Current		I_{OUT}	1	$V_{CC}=12\text{V}$	-	2.5	-	mA
Input Limiting Voltage		$V_{IN(lim)}$	2	$V_{CC}=12\text{V}, f=10.7\text{MHz}$	-	600	-	μV
Maximum Output Voltage		V_{OM}	2	$V_{CC}=12\text{V}, V_{IN}=10\text{mV}, f=10.7\text{MHz}$	-	800	-	mV
Power Gain		G_p	2	$V_{CC}=12\text{V}, f=10.7\text{MHz}$	66	69	72	dB
IF Voltage Gain		$G_V(\text{IF})$	5	$V_{CC}=12\text{V}, f=10.7\text{MHz}, 50\text{dB}\mu\text{V}$	-	56	-	dB
Input Impedance	Parallel Input Resistance	r_{ip}	3	$V_{CC}=12\text{V}, f=10.7\text{MHz}$	-	5	-	$\text{k}\Omega$
	Parallel Input Capacitance	c_{ip}			-	6	-	pF
Output Impedance	Parallel Output Resistance	r_{op}	4	$V_{CC}=12\text{V}, f=10.7\text{MHz}$	-	10	-	$\text{k}\Omega$
	Parallel Output Capacitance	c_{op}			-	5	-	pF

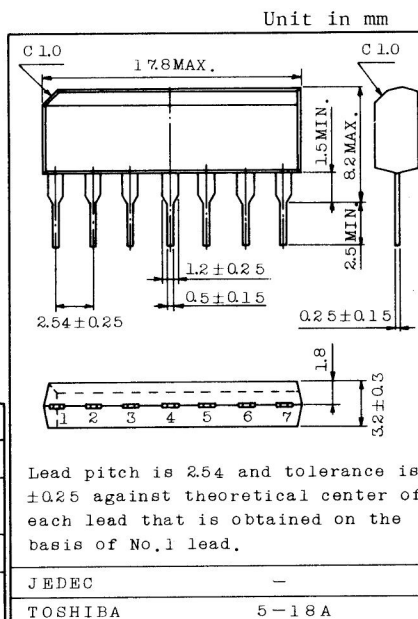



INTEGRATED CIRCUIT

TECHNICAL DATA

TA7061AP

EQUIVALENT CIRCUIT

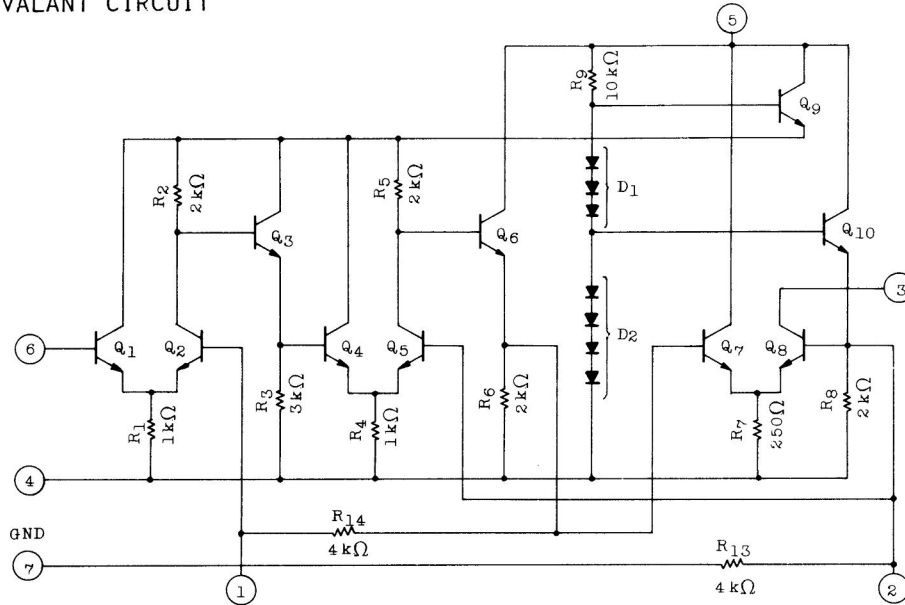

TEST CIRCUIT

1. I_{CC} , I_{OUT}

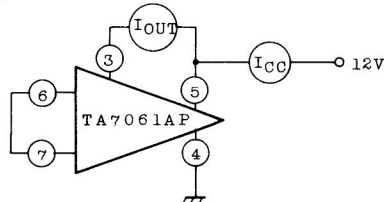

2. $V_{IN(1im)}$, V_{OM} , G_p

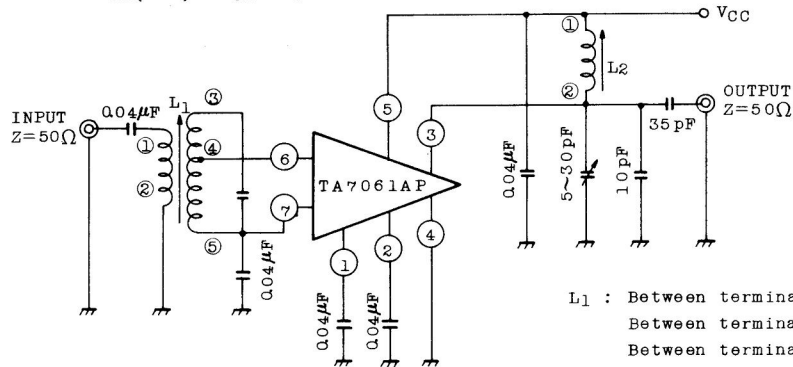

L_1 : Between terminals ① and ② 3 Turns
 Between terminals ③ and ④ 10 Turns
 Between terminals ⑤ and ⑥ 13 Turns
 L_2 : Between terminals ① and ② 13 Turns
 $\phi 1mm \varnothing$ UEW



INTEGRATED CIRCUIT

TECHNICAL DATA

TA7061AP

3. r_{ip}, c_{ip}

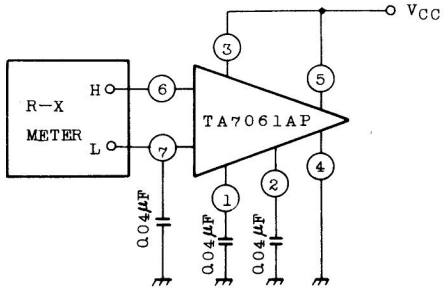

4. r_{op}, c_{op}

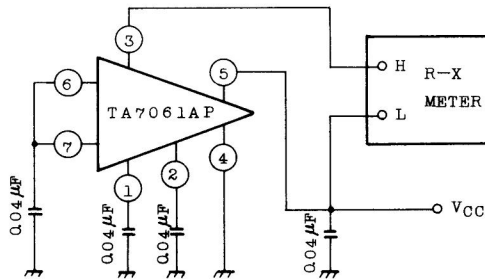

5. $G_V(f)$

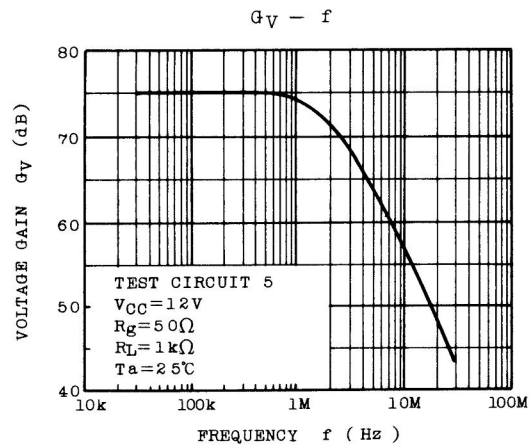
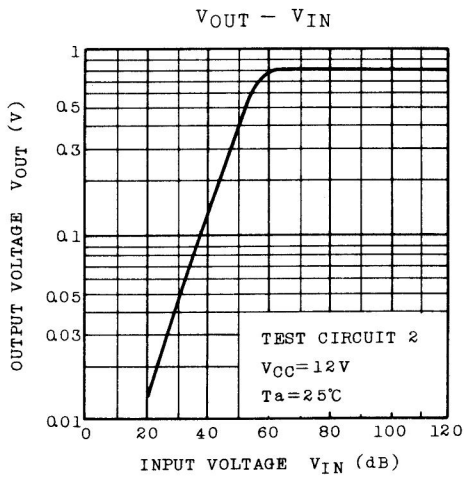
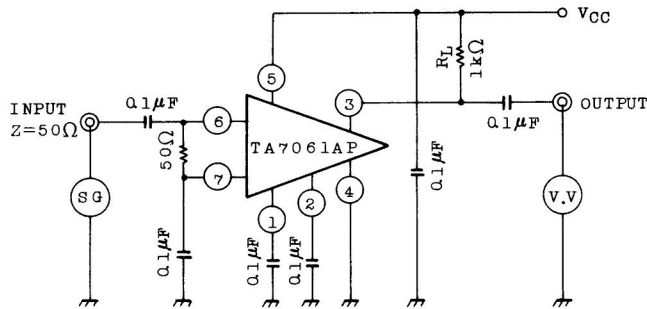



INTEGRATED CIRCUIT

TECHNICAL DATA

TA7061AP

APPLICATION CIRCUIT

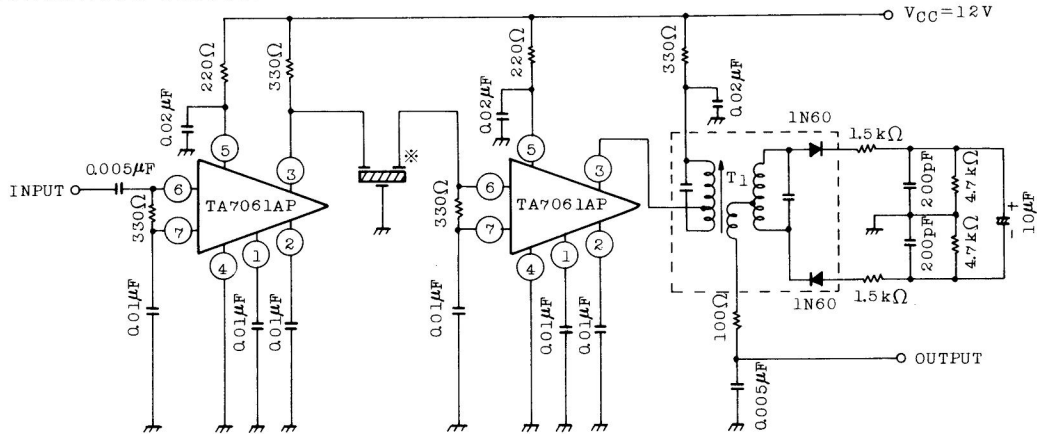

* CERAMIC FILTER CFP-1Q7MA (MURATA)

CHARACTERISTIC	SYMBOL	TEST CONDITION	VALUE	UNIT
Supply Current	I_{CC}	$V_{CC}=12V$	21	mA
Recovered Output Voltage	V_{OD}	$V_{IN}=60dB(\mu V)$, $f=400Hz$ $\Delta f=\pm 22.5kHz$	90	mV
Input Limiting Voltage	$V_{IN}(lim)$	-3dB Limiting	22	$dB\mu V$
Total Harmonic Distortion	THD	$V_{IN}=60dB(\mu V)$, $f=400Hz$ $\Delta f=\pm 75kHz$	0.5	%
AM Rejection Ratio	AMR	FM : $f=400Hz$, $\Delta f=\pm 75kHz$ $V_{IN}=80dB\mu V$, AM : $f=1kHz$, 30%	60	dB
Capture Ratio	-	$f=400Hz$, $\Delta f=\pm 75kHz$	3	dB

COIL DATA (V4FCD 1175BW TOKO INC)

	C_0 (pF)		f (MHz)	Q_0		TURNS				
	1-3	4-6		1-3	4-6	1-3	1-2	5-CT	4-CT	6-CT
T	22	46	10.7	60	50	31½	11	9½	11	11

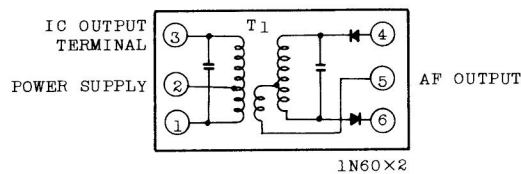

TOSHIBA CORPORATION

