

RoHS Compliant Product
A suffix of "-C" specifies halogen-free

FEATURES

- Batch process design, excellent power dissipation offers better reverse leakage current and thermal resistance.
- Low profile surface mounted application in order to optimize board space.
- High current capability.
- Fast switching for high efficiency.
- Glass passivated chip junction.

SOD-123M

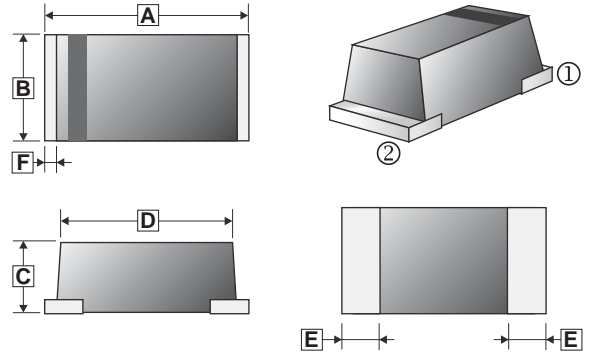

MECHANICAL DATA

- Case: Molded plastic, SOD-123M / Mini SMA
- Epoxy: UL94-V0 rated flame retardant
- Terminals: Plated terminals, solderable per MIL-STD-750, Method 2026.
- Polarity: Indicated by cathode band
- Weight: 0.018 gram (Approximately)

MARKING CODE

Part Number	Marking Code	Part Number	Marking Code
SEF101M	H1	SEF105M	H5
SEF102M	H2	SEF106M	H6
SEF103M	H3	SEF107M	H7
SEF104M	H4		

REF.	Millimeter		REF.	Millimeter	
	Min.	Max.		Min.	Max.
A	3.50	3.90	D	3.60 (Max.)	
B	1.40	1.80	E	0.80 (Typ.)	
C	1.30	1.70	F	0.30 (Typ.)	

PACKAGE INFORMATION

Package	MPQ	LeaderSize
SOD-123M	2.5K	7' inch

ABSOLUTE MAXIMUM RATINGS ($T_A = 25^\circ\text{C}$ unless otherwise specified.)

Parameter	Symbol	Part Number							Unit
		SEF 101M	SEF 102M	SEF 103M	SEF 104M	SEF 105M	SEF 106M	SEF 107M	
Repetitive Peak Reverse Voltage (Max.)	V_{RRM}	50	100	200	400	600	800	1000	V
RMS Voltage (Max.)	V_{RMS}	35	70	140	280	420	560	700	V
Continuous Reverse Voltage (Max.)	V_R	50	100	200	400	600	800	1000	V

ELECTRICAL CHARACTERISTICS ($T_A = 25^\circ\text{C}$ unless otherwise specified)

Parameter	Symbol	Part Number							Unit	Testing Condition
		SEF 101M	SEF 102M	SEF 103M	SEF 104M	SEF 105M	SEF 106M	SEF 107M		
Forward Voltage (Max.)	V_F	1			1.3	1.7			V	
Average Forward Rectified Current (Max.)	I_O	1							A	Ambient Temperature =50°C
Forward Surge Current	I_{FSM}	30							A	8.3ms single half sine-wave superimposed on rated load (JEDEC method)
DC Reverse Current at Rated DC Blocking Voltage (Max.)	I_R	5							μA	$V_R=V_{RRM}, T_A=25^\circ\text{C}$
		150								$V_R=V_{RRM}, T_A=100^\circ\text{C}$
Thermal Resistance Junction to Ambient (Typ.)	$R_{\theta JA}$	42							$^\circ\text{C/W}$	
Diode Junction Capacitance (Typ.)	C_J	20							pF	f=1MHz and applied 4V DC reverse voltage
Storage and Operating Temperature Range	T_{STG}, T_J	-65 ~ 175, -55 ~ 150							$^\circ\text{C}$	
Reverse recovery time	T_{RR}	50				75			nS	

Note:

- Reverse recovery time test condition, $I_F=0.5\text{A}$, $I_R=1\text{A}$, $I_{RR}=0.25\text{A}$.

RATINGS AND CHARACTERISTIC CURVES

FIG.1-TYPICAL FORWARD CHARACTERISTICS

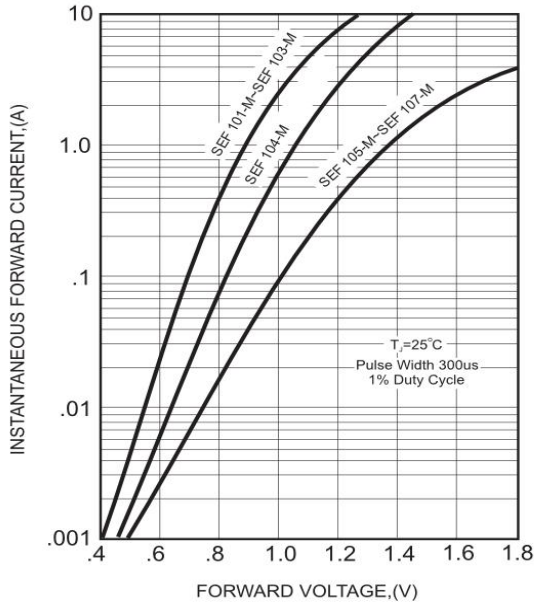

FIG.2-TYPICAL FORWARD CURRENT DERATING CURVE

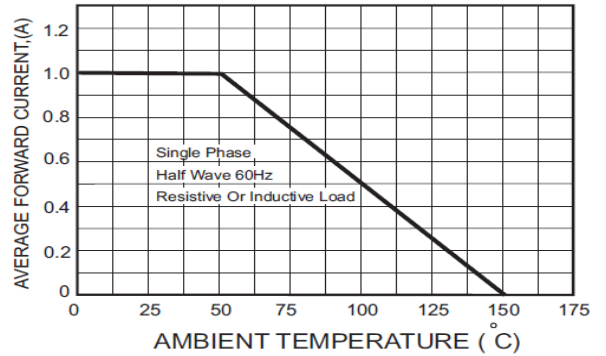
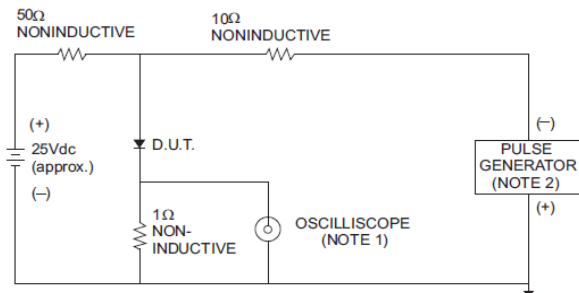

FIG.3- TEST CIRCUIT DIAGRAM AND REVERSE RECOVERY TIME CHARACTERISTICS



- NOTES: 1. Rise Time= 7ns max., Input Impedance= 1 megohm.22pF.
2. Rise Time= 10ns max., Source Impedance= 50 ohms.

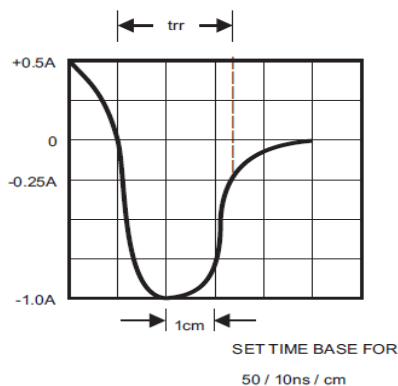

FIG.4-MAXIMUM NON-REPETITIVE FORWARD SURGE CURRENT

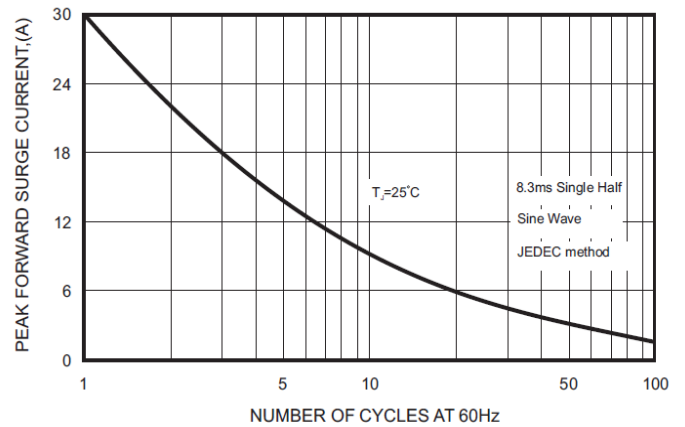

FIG.5-TYPICAL JUNCTION CAPACITANCE

