

INNOLUX DISPLAY CORPORATION

LCD MODULE

SPECIFICATION

Customer: _____

Model Name: PT035TN01

SPEC NO.: P035-01-TT-01

Date: 2005/05/23

Version: 1

Preliminary Specification

Final Specification

For Customer's Acceptance

Approved by	Comment

Approved by	Reviewed by	Prepared by

Record of Revision

Version	Revise Date	Page	Content
1	2005/05/23		Initial Release

1.	General Specifications	1
2.	Pin Assignment	2
2.1.	TFT LCD Panel Driving Section.....	2
3.	Operation Specifications	5
3.1.	Absolute Maximum Rating.....	5
3.2.	Electrical Characteristics	6
3.2.1.	Typical Operation Conditions	6
3.2.2.	Current Consumption.....	7
3.2.3.	Backlight Driving Condition	7
3.3.	Timing Characteristics	8
3.3.1.	Timing Conditions	8
3.3.2.	Timing Diagram.....	9
4.	Optical Specifications	14
5.	Reliability Test Items.....	18
6.	Handling Precautions	20
6.1.	Safety	20
6.2.	Handling	20
6.3.	Static Electricity	20
6.4.	Storage	20
6.5.	Cleaning	20
7.	Mechanical Drawing	21
8.	Package Drawing	22

1. General Specifications

No.	Item	Specification	Remark
1	LCD size	3.45" inch	
2	Driver element	a-Si TFT active matrix	
3	Resolution	320X3(RGB)X240	
4	Display mode	Normally White, Transmissive	
5	Dot pitch	0.073(W)X0.219(H) mm	
6	Active area	70.08(W)X52.56(H) mm	
7	Module size	78.2(W)X65.0(H)X3.2(D) mm	Note 1
8	Surface treatment	Anti Glare	
9	Color arrangement	RGB-stripe	
10	Interface	Digital	
11	Power Consumption	TBD	
12	Weight	TBD	

Note 1: Refer to Mechanical Drawing.

2. Pin Assignment

2.1. TFT LCD Panel Driving Section

Pin No.	Symbol	I/O	Function	Remark
1	NC	-	No connect	
2	V _{GL}	I	Negative power for scan driver	
3	V _{COM}	I	V _{COM} input	
4	V _{CC}	P	Supply voltage of logic control circuit for scan driver	
5	STB	I	Standby mode control. Normally pull high	
6	DEN	I	Input data enable control	
7	V _{SYNC}	I	Vertical sync input.	
8	H _{SYNC}	I	Horizontal sync input	
9	CLK	I	Clock signal	
10	D00	I	Data INPUT(LSB)	
11	D01	I	Data INPUT	
12	D02	I	Data INPUT	
13	D03	I	Data INPUT	
14	D04	I	Data INPUT	
15	D05	I	Data INPUT	
16	D06	I	Data INPUT	
17	D07	I	Data INPUT (MSB)	
18	AGND	P	Analog ground.	
19	V1	P	Gamma Correction reference voltage.	
20	V2	P	Gamma Correction reference voltage.	

21	V3	P	Gamma Correction reference voltage	
22	V4	P	Gamma Correction reference voltage	
23	V5	P	Gamma Correction reference voltage	
24	V6	P	Gamma Correction reference voltage	
25	V7	P	Gamma Correction reference voltage	
26	V8	P	Gamma Correction reference voltage	
27	AV _{DD}	P	Analog power supply(+5V)	
28	Q1H	I	Data Sequence control.	
29	NC	-	No connect	
30	POL	O	Polarity select for the line inversion control signal.	
31	SPDA	I/O	Serial port Data input/output	
32	SPCK	I	Serial port Clock .Normally pull high	
33	SPENA	I	Serial port Data Enable Signal. Normally pull high	
34	IF1	I	Data Format selection	
35	IF2	I	Data Format selection	
36	L/R	I	LEFT/RIGHT Setting	
37	U/D	I	UP/DOWN Setting.	
38	VSET	I	Gamma correction voltage is set internally or externally. Normally pull	
39	RSTB	I	Reset Pin	
40	GND	P	Ground for logic circuit	
41	V _{COM}	I	V _{COM} input	
42	V _{GH}	P	Positive power for scan driver	
43	V _{GL}	P	Negative power for scan driver	
44	G_V _{DD}	P	V _{DD} for gate driver	
45	G_V _{SS}	P	V _{SS} for gate driver	

46	VLED1	P	Power for LED	
47	GLED1	P	GND for LED	
48	VLED2	P	Power for LED	
49	GLED2	P	GND for LED	
50	NC	-	No connect	

3. Operation Specifications

3.1. Absolute Maximum Rating

(GND=AGND=0V, Note 1)

Item	Symbol	Values		Unit	Remark
		Min.	Max.		
Power voltage	V_{CC}	-0.3	7	V	
	AV_{DD}	-0.3	7	V	
	V_{GH}	-0.3	18	V	
	V_{GL}	-15	0.3	V	
	$V_{GH}-V_{GL}$	-	33	V	
Operation Temperature	T_{OP}	-20	60	°C	
Storage Temperature	T_{ST}	-30	70	°C	

Note 1: The absolute maximum rating values of this product are not allowed to be exceeded at any times. The module should be used with any of the absolute maximum ratings exceeded, the characteristics of the module may not be recovered, or in an extreme case, the module may be permanently destroyed.

3.2. Electrical Characteristics

3.2.1. Typical Operation Conditions

(GND=AGND=0V, Note 2)

Item	Symbol	Values			Unit	Remark
		Min.	Typ.	Max.		
Power voltage	V_{CC}	3.0	3.3	3.6	V	
	AV_{DD}	-	5.0	-	V	
	V_{GH}	-	TBD	-	V	
	V_{GL}	-	TBD	-	V	
V_{COM}	V_{CAC}	-	TBD	-	V	Note 1
	V_{CDC}	-	TBD	-	V	DC component
Input logic high voltage	V_{IH}	$0.7V_{CC}$	-	V_{CC}	V	
Input logic low voltage	V_{IL}	0	-	$0.3V_{CC}$	V	

Note 1: The brightness of LCD panel could be changed by adjusting the AC component of V_{COM} .

Note 2: Be sure to apply GND, V_{CC} , and V_{GL} , to the LCD first, and then apply V_{GH} .

3.2.2. Current Consumption

(GND=AGND=0V)

Item	Symbol	Values			Unit	Remark
		Min.	Typ.	Max.		
Current for Driver	I _{GH}	-	TBD	-	mA	V _{GH} =TBD
	I _{GL}	-	TBD	-	mA	V _{GL} = TBD
	I _{CC}	-	TBD	-	mA	V _{CC} =3.3V
	I _{DD}	-	TBD	-	mA	AV _{DD} =5V

3.2.3. Backlight Driving Condition

Item	Symbol	Values			Unit	Remark
		Min.	Typ.	Max.		
LED voltage	V _L	-	(3.6)	-	V	Note 2
LED current	I _L	-	(20)	-	mA	Note 2
LED life time	-	7,000	-	-	Hr	Note 1

Note 1: The “LED life time” is defined as the module brightness decrease to 50% original brightness that the ambient temperature is 25°C and I_L =20mA.

Note 2: The LED driving condition is defined for each LED module.(See the figure)

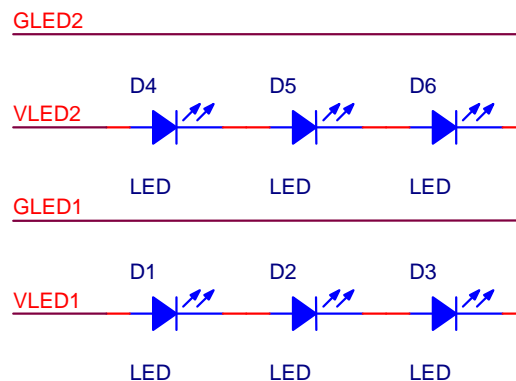

3.3. Timing Characteristics

3.3.1. Timing Conditions

Item	Symbol	Values			Unit.	Remark	
		Min.	Typ.	Max.			
CLK	T _{Osc}	-	52	-	ns		
Data setup time	T _{SU}	12	-	-	ns		
Data hold time	T _{HD}	12	-	-	ns		
IHS period	T _H	-	1224	-	T _{Osc}		
IHS pulse width	T _{HS}	5	90	-	T _{Osc}		
IHS rising time	T _{Cr}	-	-	700	ns		
IHS falling time	T _{Cf}	-	-	300	ns		
IVS pulse width	T _{Vs}	1	3	5	T _H		
IVS rising time	T _{Vr}	-	-	700	ns		
IVS falling time	T _{Vf}	-	-	1.5	us		
IVS falling to HIS rising time for odd field	T _{HVO}	3	-	-	T _{Osc}		
IVS falling to HIS falling time for even field	T _{HVE}	3	-	-	T _{Osc}		
IVS-DEN time	NTSC	T _{VSE}	-	18	-	T _H	
	PAL			26			
IHS-DEN time	T _{HE}	108	204	264	T _{Osc}		
DEN pulse width	T _{EP}	-	960	-	T _{Osc}		
DEN-STH time	T _{DES}	-	3	-	T _{Osc}		
IVS period	NTSC		-	262.5	-	T _H	
	PAL		-	312.5	-	T _H	

3.3.2. Timing Diagram

CCIR601 (HS_POL="L" in Register R2)

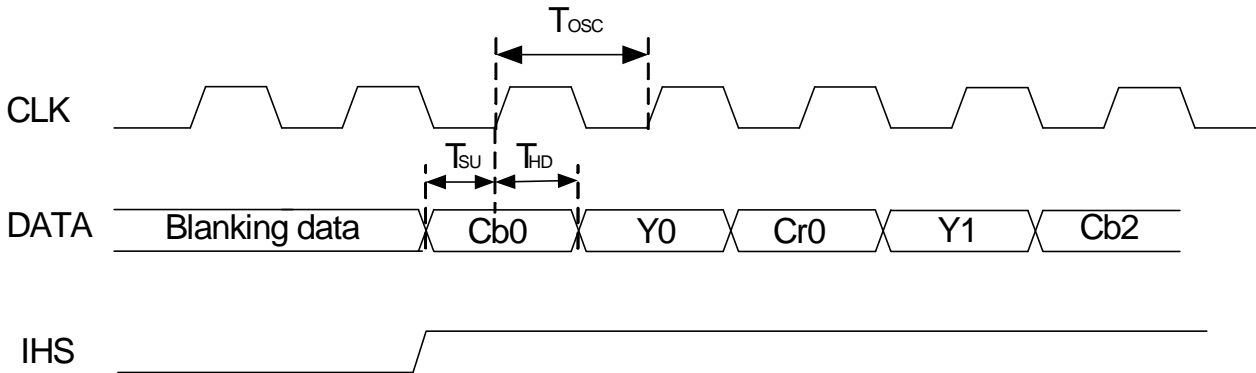

CCIR656

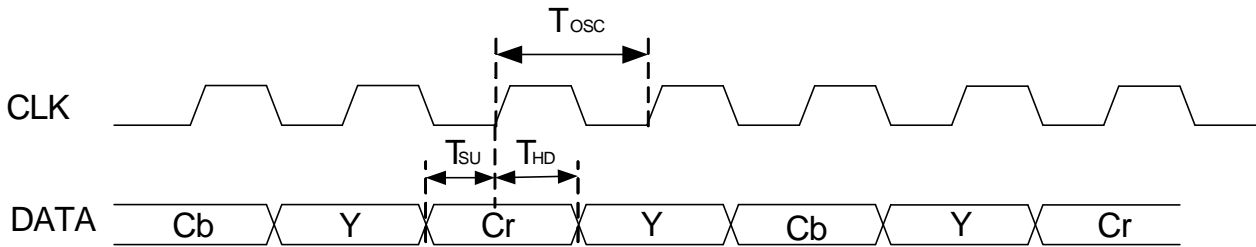

Digital Serial RGB

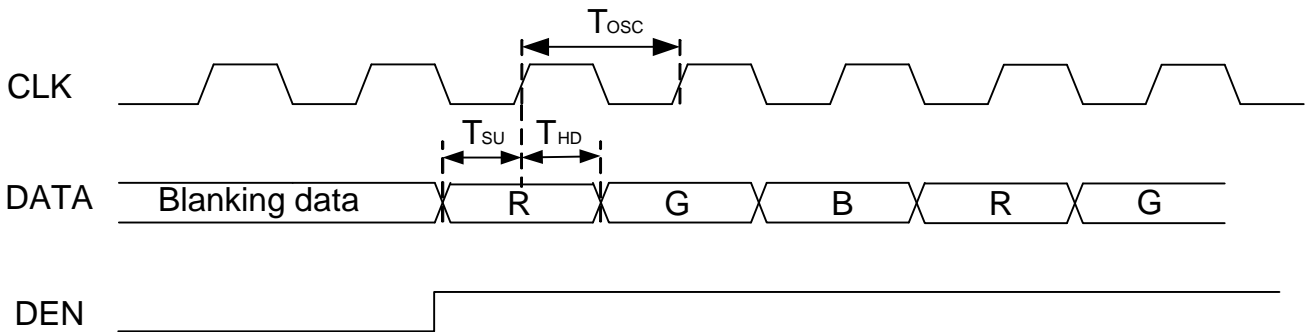

IHS and horizontal control timing waveform

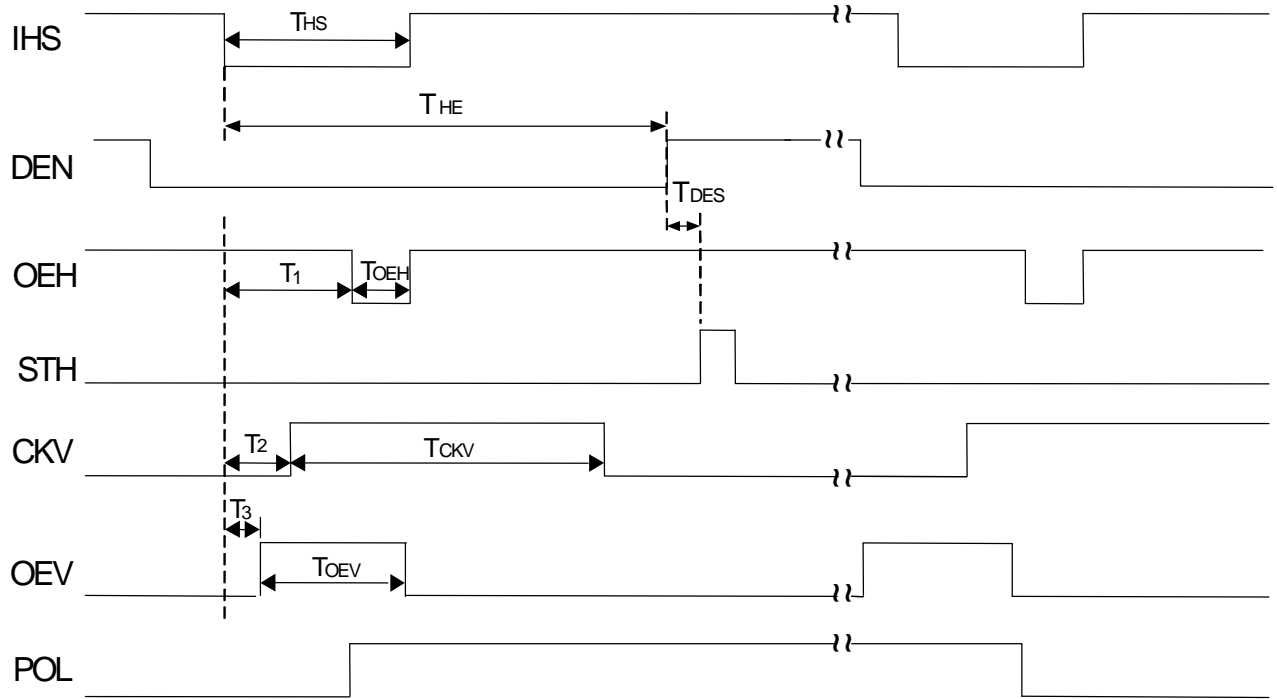

IHS and vertical shift clock timing waveform

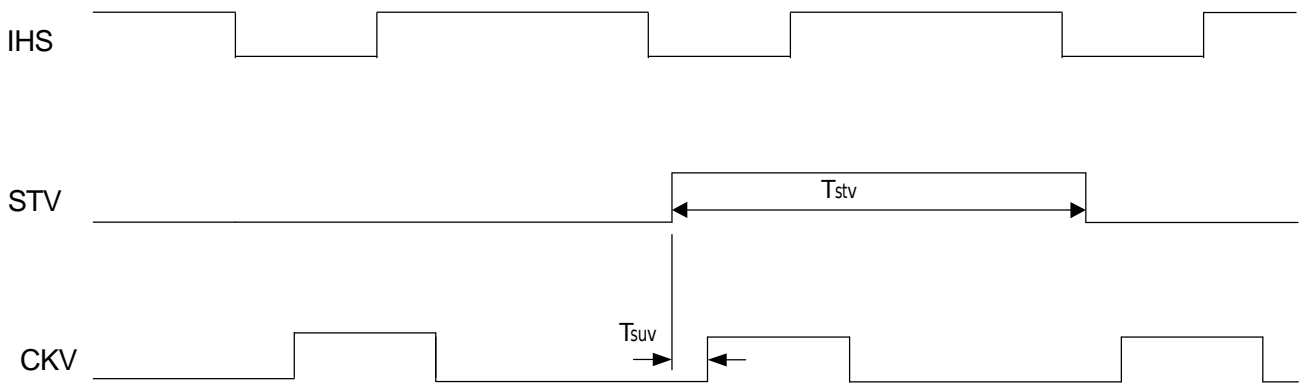

IHS and vertical control timing waveform

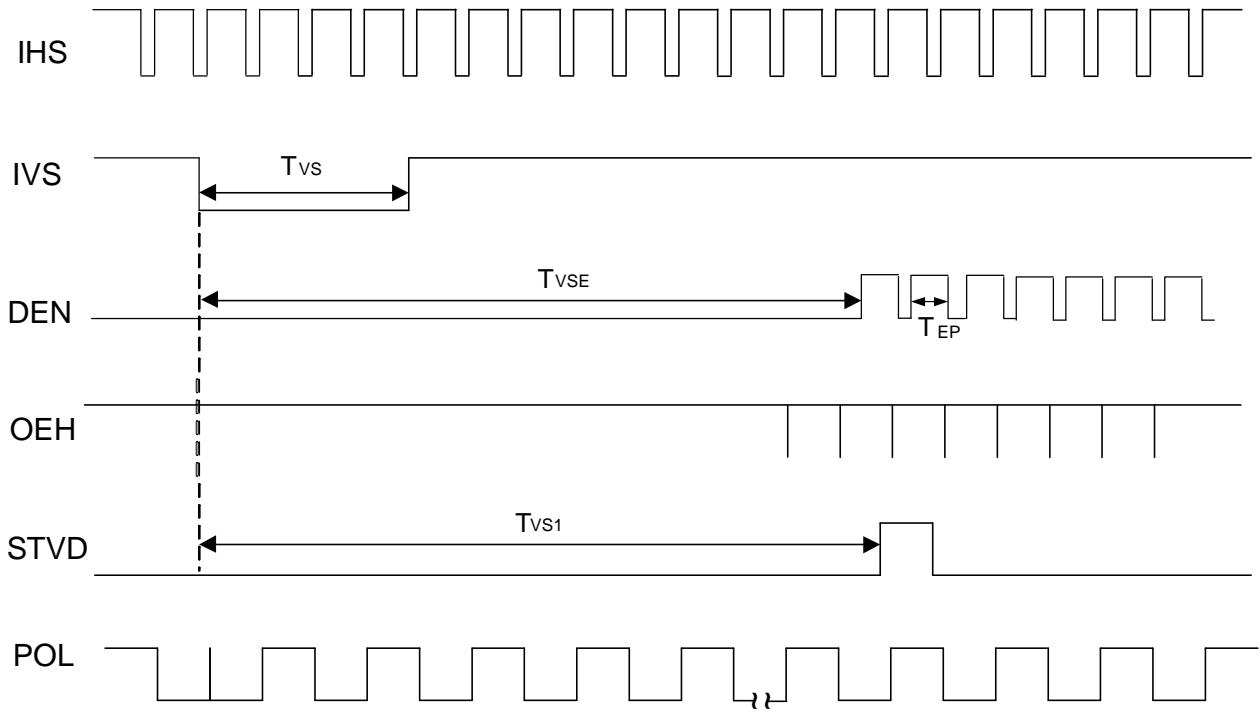

CCIR601 timing waveform VS_POL="H", HS_POL="L" in Register R2)

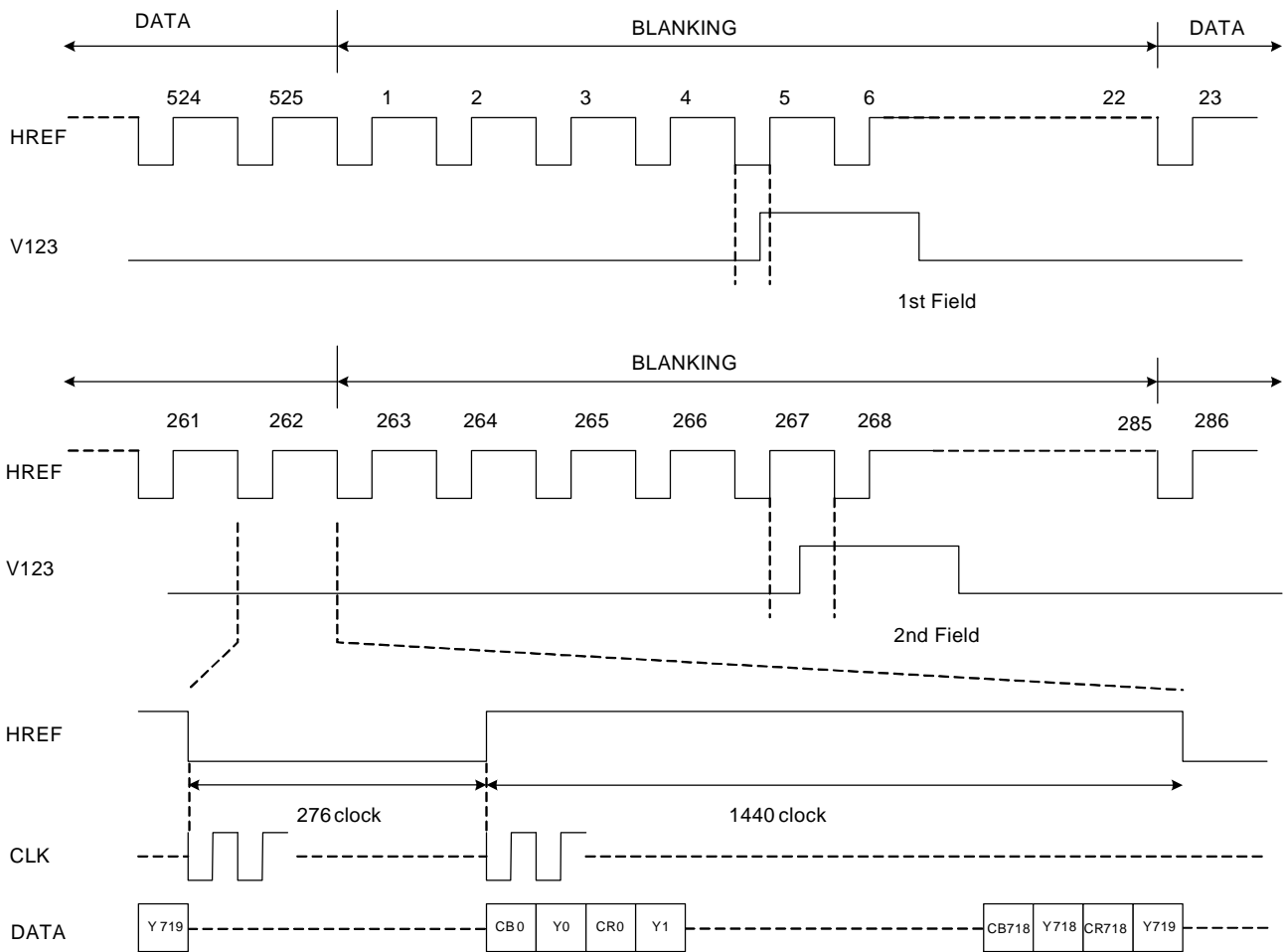

ITU-R BT. 601 NTSC Input Timing

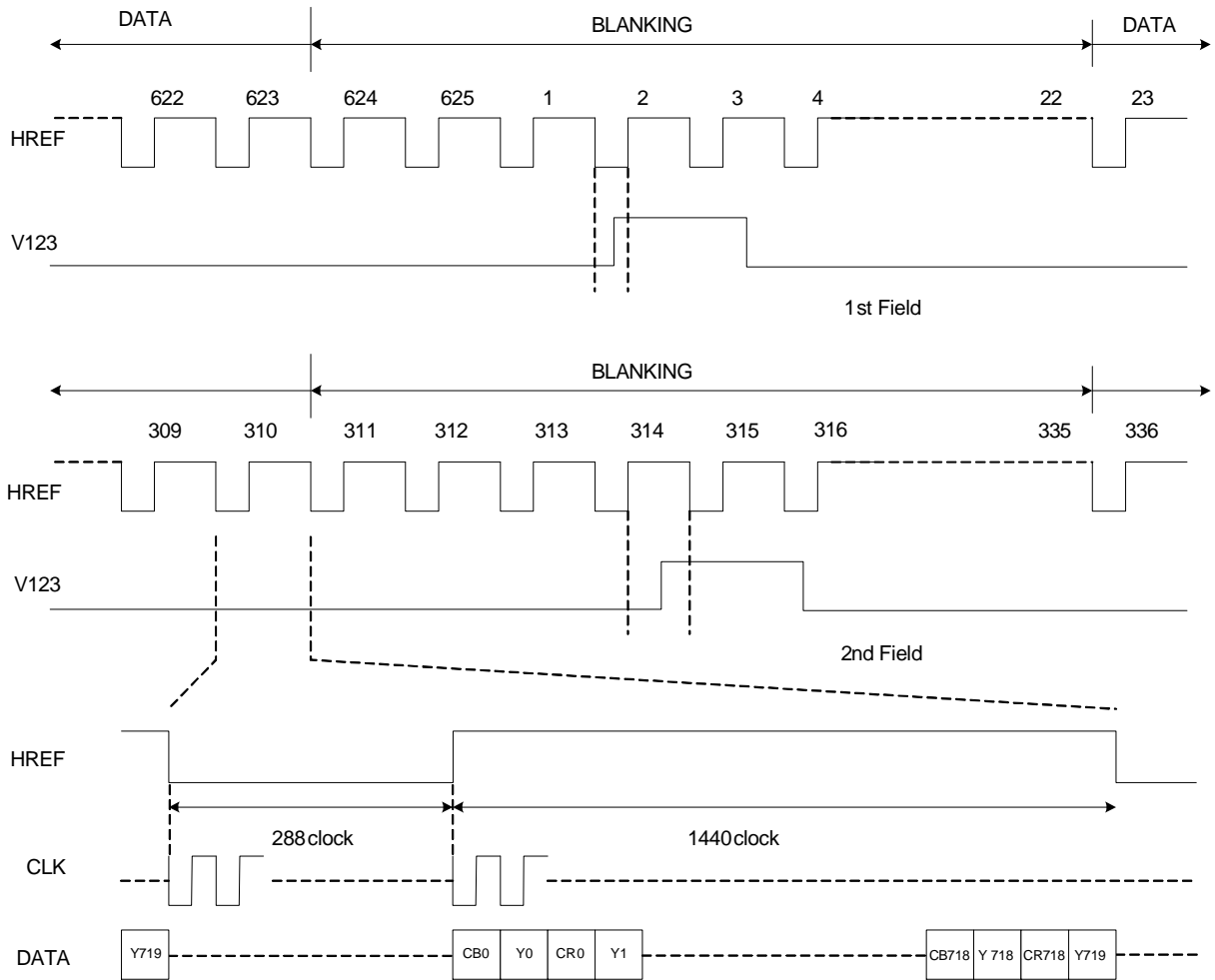

ITU-R BT. 601 PAL Input Timing

4. Optical Specifications

Item	Symbol	Condition	Min.	Typ.	Max.	Unit	Remark
Viewing angle (CR≥10)	θ_L	$\Phi=180^\circ$ (9 o'clock)	55	65	-	degree	Note 1
	θ_R	$\Phi=0^\circ$ (3 o'clock)	55	65	-		
	θ_T	$\Phi=90^\circ$ (12 o'clock)	35	45	-		
	θ_B	$\Phi=270^\circ$ (6 o'clock)	55	65	-		
Response Time	T_{ON}	Normal $\theta=\Phi=0^\circ$	-	15	30	msec	Note 3
	T_{OFF}		-	20	50	msec	Note 3
Contrast ratio	CR		200	300	-	-	Note 4
Color chromaticity	W_X		-	TBD	-	-	Note 5 Note 6
	W_Y		-	TBD	-	-	
	R_X		-	TBD	-	-	
	R_Y		-	TBD	-	-	
	G_X		-	TBD	-	-	
	G_Y		-	TBD	-	-	
	B_X		-	TBD	-	-	
	B_Y	-	TBD	-	-		
Luminance	L	200	250	-	cd/m ²	Note 6	
Luminance uniformity	Y_U	70	75	-	%	Note 7	

Test Conditions:

- $V_{CC}=3.3V$, $AV_{DD}=5.0V$, $I_L=20mA$ (Backlight current), the ambient temperature is 25°C.
- The test systems refer to Note 2.

Note 1: Definition of viewing angle range

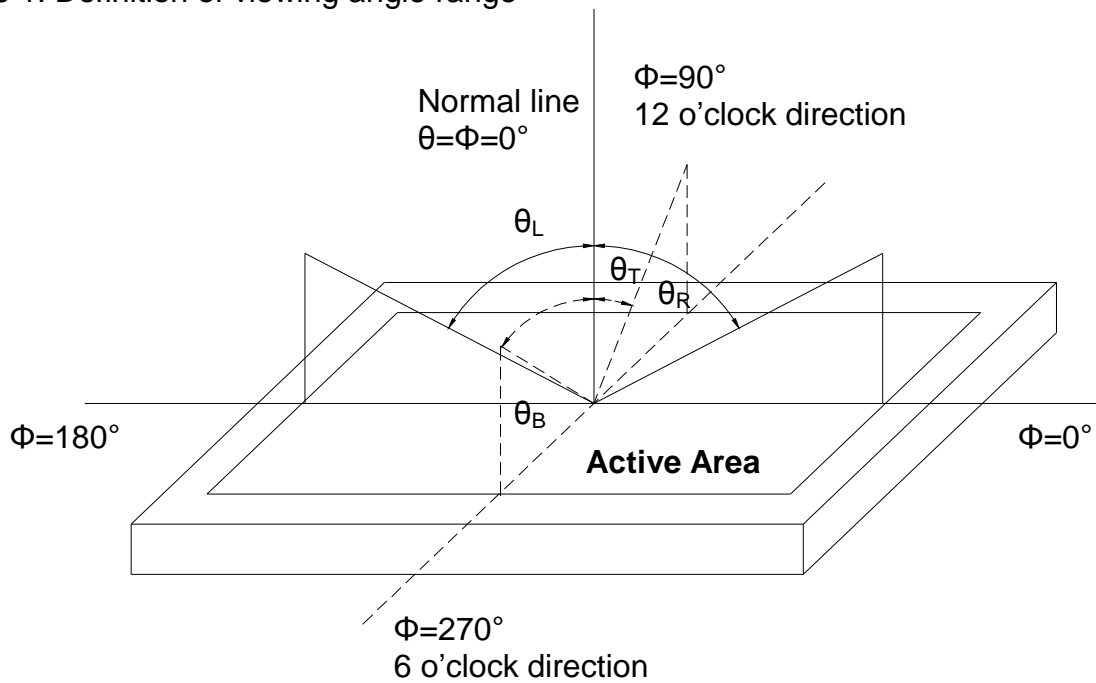

Fig. 4-1 Definition of viewing angle

Note 2: Definition of optical measurement system. (TFT)

The optical characteristics should be measured in dark room. After 30 minutes operation, the optical properties are measured at the center point of the LCD screen. (Response time is measured by Photo detector TOPCON BM-7, other items are measured by BM-5A/Field of view: 1° /Height: 500mm.)

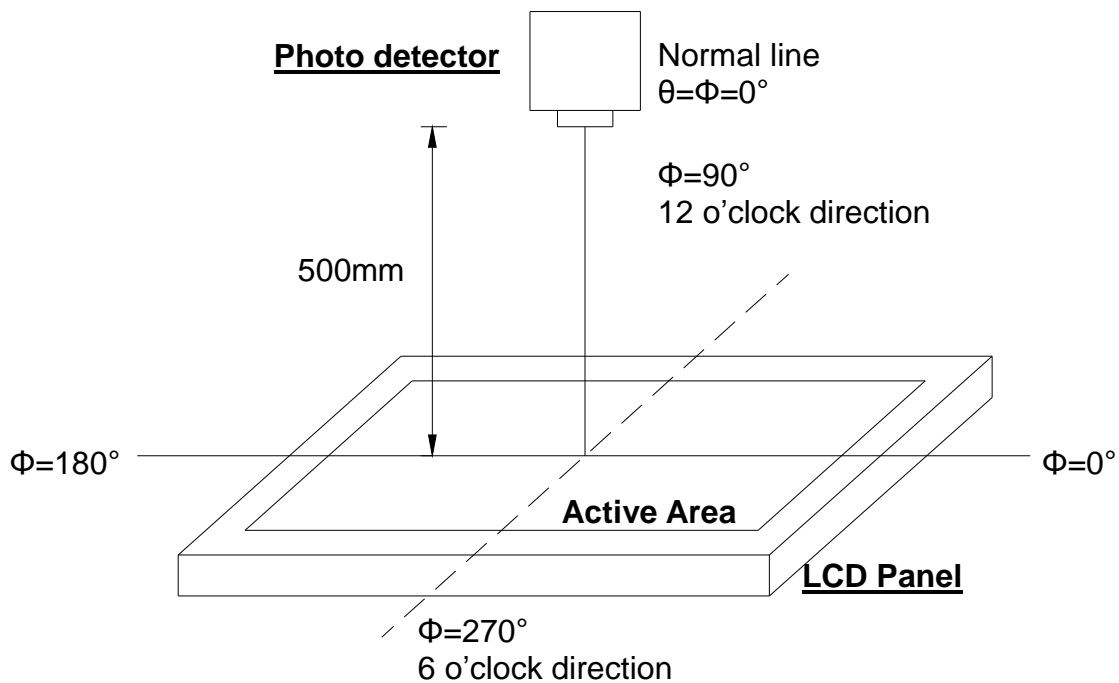

Fig. 4-2 Optical measurement system setup

Note 3: Definition of Response time

The response time is defined as the LCD optical switching time interval between "White" state and "Black" state. Rise time (T_{ON}) is the time between photo detector output intensity changed from 90% to 10%. And fall time (T_{OFF}) is the time between photo detector output intensity changed from 10% to 90%.

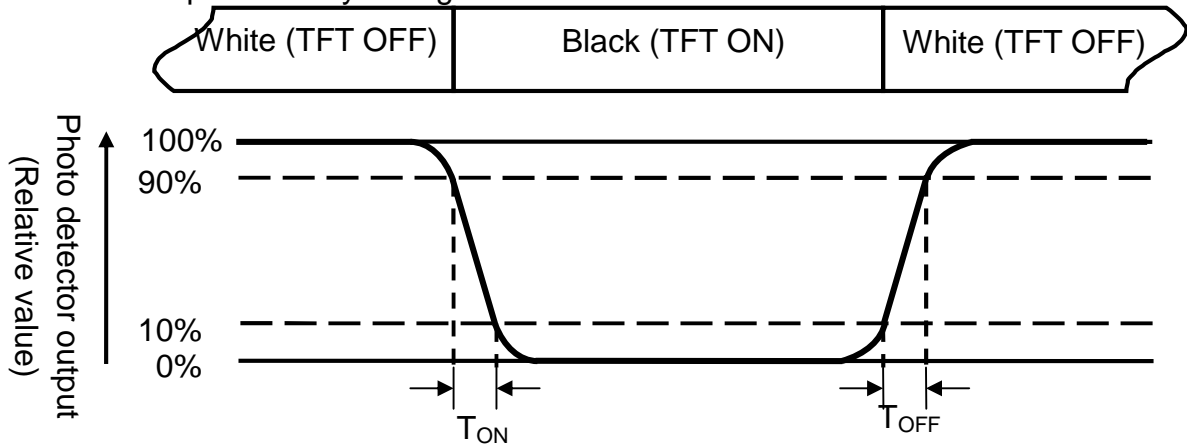

Fig. 4-3 Definition of response time

Note 4: Definition of contrast ratio

$$\text{Contrast ratio (CR)} = \frac{\text{Luminance measured when LCD is on the "White" state}}{\text{Luminance measured when LCD is on the "Black" state}}$$

Note 5: Definition of color chromaticity (CIE1931)

Color coordinates measured at center point of LCD.

Note 6: All input terminals LCD panel must be ground when measuring the center area of the panel.

Note 7: Definition of Luminance Uniformity

To test for uniformity, the tested area, which is inside the active area, is divided into 3 rows and 3 columns. The measurement spot is placed at the center of each box.

$$\text{Luminance Uniformity (Yu)} = \frac{B_{min}}{B_{max}}$$

L-----Active area length W----- Active area width

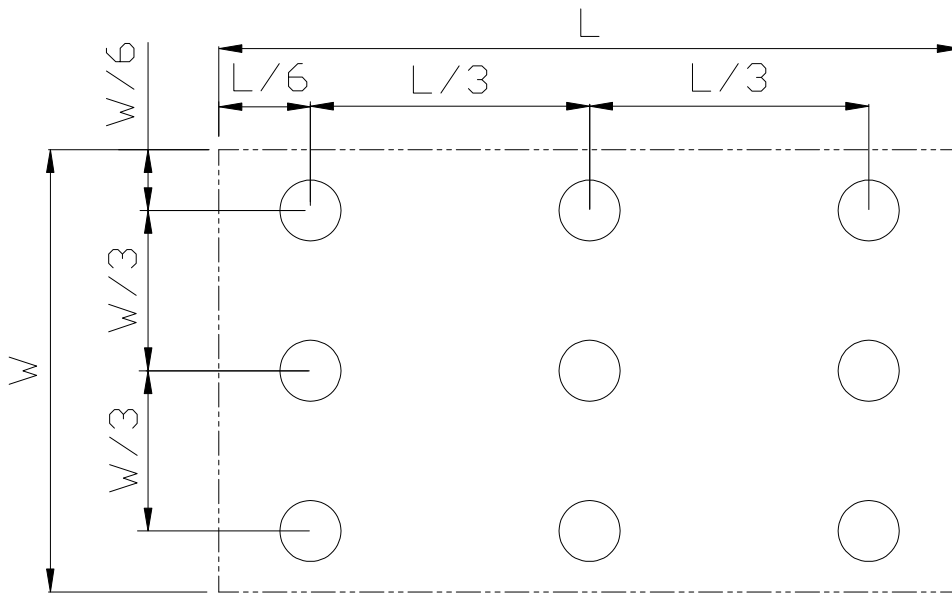

Fig. 4-4 Definition of uniformity

B_{max}: The measured maximum luminance of all measurement position.

B_{min}: The measured minimum luminance of all measurement position.

5. Reliability Test Items

Item	Test Conditions	Remark
High Temperature Storage	Ta = 70°C 240 hrs	Note 1
Low Temperature Storage	Ta = -30°C 240hrs	Note 1
High Temperature Operation	Ts = 60°C 240hrs	Note 2
Low Temperature Operation	Ta = -20°C 240hrs	Note 1
Operate at High Temperature and Humidity	+60°C, 90%RH max. 240 hrs	
Thermal Shock	-30°C/30 min ~ +80°C/30 min for a total 100 cycles, Start with cold temperature and end with high temperature	
Vibration Test	Frequency range:10~55Hz Stroke:1.5mm Sweep:10Hz~55Hz~10Hz 2 hours for each direction of X. Y. Z. (6 hours for total)	JIS C7021 A-10 Condition A
Mechanical Shock	100G 6ms,±X, ±Y, ±Z 3 times for each direction	JIS C7021 A-7 Condition C
Package Vibration Test	Random Vibration : 0.015G*G/Hz from 5-200HZ, -6dB/Octave from 200-500HZ 2 hours for each direction of X. Y. Z. (6 hours for total)	IEC 68-34
Package Drop Test	Height:60 cm 1 corner, 3 edges, 6 surfaces	JIS Z0202
Electro Static Discharge	± 2KV, Human Body Mode, 100pF/1500Ω	EIA/JESD22-A114

Note 1: Ta is the ambient temperature of samples.

Note 2: Ts is the temperature of panel's surface.

$$T_s = (T_{s1} + T_{s2} + T_{s3} + T_{s4} + T_{s5}) / 5$$

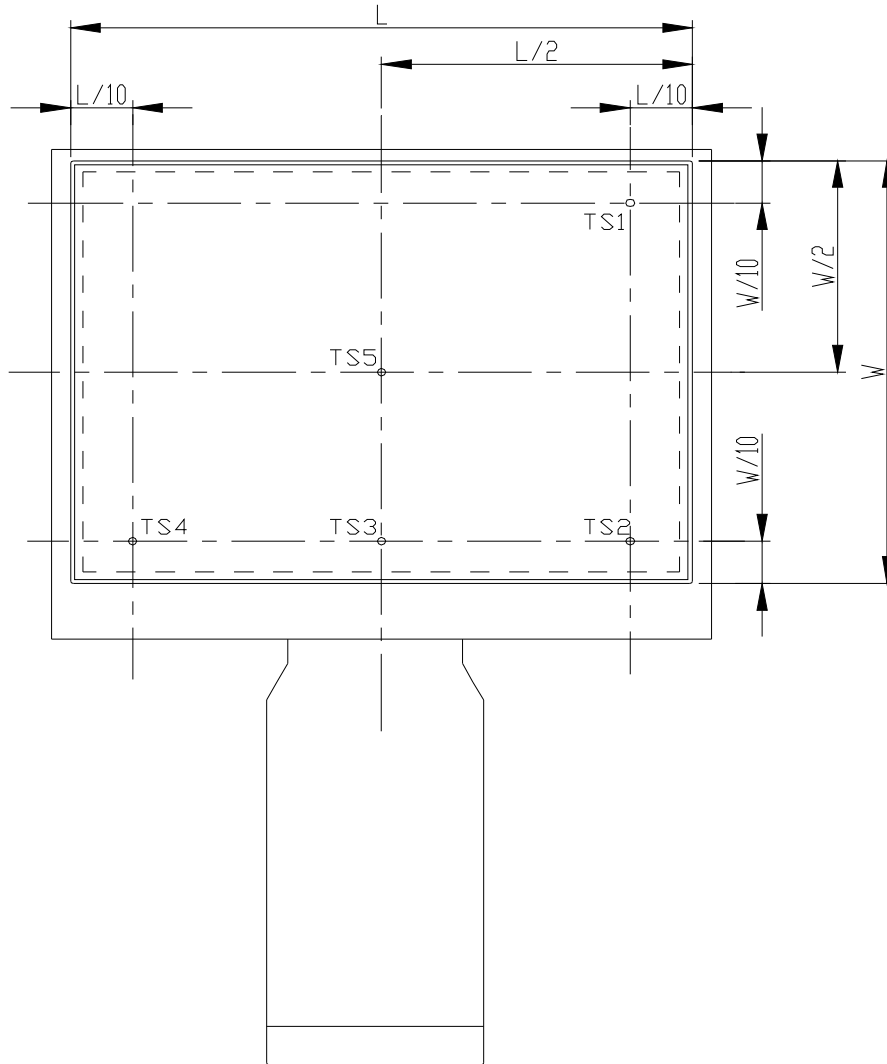

L is the length of Top Bezel open window,
 W is the width of Top Bezel open window.

Note 3: In the standard condition, there shall be no practical problem that may affect the display function.

6. Handling Precautions

6.1. Safety

The liquid crystal in the LCD is poisonous. **DO NOT** put it in your mouth. If the liquid crystal touches your skin or clothes, wash it off immediately using soap and water.

6.2. Handling

1. The LCD panel is plate glass. **DO NOT** subject the panel to mechanical shock or to excessive force on its surface.
2. The polarizer attached to the display is very easy to damage, handle it with careful attention.
3. To avoid contamination on the display surface, **DO NOT** touch the display surface with bare hands.
4. Provide a space so that the LCD panel does not come into contact with other components.
5. To protect the LCD panel from external pressure, put covering glass (acrylic board or similar board) keeping appropriate gap between them.
6. Transparent electrodes may be disconnected if you use the LCD panel under environmental conditions where dew condensation occurs.
7. Property of semiconductor devices may be affected when they are exposed to light, possibly resulting in malfunctioning of the ICs.
8. To prevent such malfunctioning of the ICs, your design and mounting layout done are so that the IC is not exposed to light in actual use.

6.3. Static Electricity

1. Ground soldering iron tips, tools and testers when you operate.
2. Ground your body when handling the products.
3. **DO NOT** apply voltage to the input terminal without applying power supply.
4. **DO NOT** apply voltage which exceeds the absolute maximum rating.
5. Store the products in an anti-electrostatic container.

6.4. Storage

1. Store the products in a dark place at $+25^{\circ}\text{C} \pm 10^{\circ}\text{C}$, low humidity (65%RH or less).
2. **DO NOT** store the products in an atmosphere containing organic solvents or corrosive gases.

6.5. Cleaning

1. **DO NOT** wipe the polarizer with dry cloth, as it might cause scratch.
2. Wipe the polarizer with a soft cloth soaked with petroleum IPA, other chemical might damage.

7. Mechanical Drawing

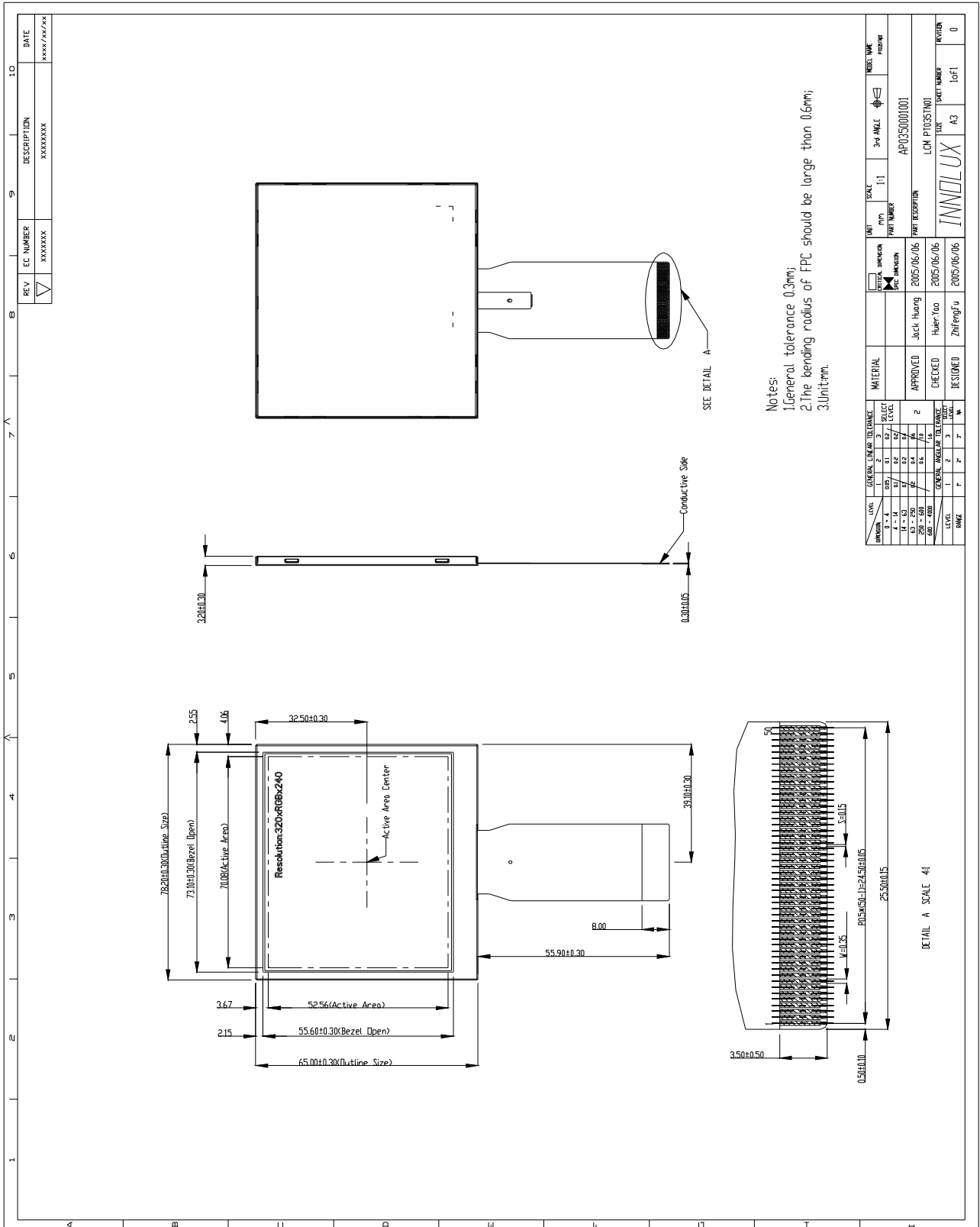

8. Package Drawing

TBD