

**Quad Programmable Up Converter**

The ISL5217 Quad Programmable Up Converter (QPUC) is a QASK/FM modulator/FDM upconverter designed for high dynamic range applications such as cellular basestations. The QPUC combines shaping and interpolation filters, a complex modulator, and timing and carrier NCOs into a single package. Each QPUC can create four FDM channels. Multiple QPUCs can be cascaded digitally to provide for up to 16 FDM channels in multi-channel applications.

The ISL5217 supports both vector and FM modulation. In vector modulation mode, the QPUC accepts 16-bit I and Q samples to generate virtually any quadrature AM or PM modulation format. The QPUC also has two FM modulation modes. In the FM with pulse shaping mode, the 16-bit frequency samples are pulse shaped/bandlimited prior to FM modulation. No band limiting filter follows the FM modulator. This FM mode is useful for GMSK type modulation formats. In the FM with band limiting filter mode, the 16-bit frequency samples directly drive the FM modulator. The FM modulator output is filtered to limit the spectral occupancy. This FM mode is useful for analog FM or FSK modulation formats.

The QPUC includes an NCO driven interpolation filter, which allows the input and output sample rate to have an integer and/or variable relationship. This re-sampling feature simplifies cascading modulators with sample rates that do not have harmonic or integer frequency relationships.

The QPUC offers digital output spectral purity that exceeds 100dB at the maximum output sample rate of 104MSPS, for input sample rates as high as 6.5MSPS.

A 16-bit microprocessor compatible interface is used to load configuration and baseband data. A programmable FIFO depth interrupt simplifies the interface to the I and Q input FIFOs.

**Features**

- Output Sample Rates Up to 104MSPS with Input Data Rates Up to 6.5MSPS
- Processing Capable of >140dB SFDR Out of Band
- Vector modulation for supporting IS-136, EDGE, IS95, TD-SCDMA, CDMA-2000-1X/3X, W-CDMA, and UMTS
- FM Modulation for Supporting AMPS, NMT, and GSM
- Four Completely Independent Channels on Chip, Each With Programmable 256 Tap Shaping FIR, Half-Band, and High Order Interpolation Filters
- 16-Bit parallel  $\mu$ Processor Interface and Four Independent Serial Data Inputs
- Two 20-bit I/O Buses and Two 20-bit Output Buses Allow Cascading Multiple Devices
- 32-Bit Programmable Carrier NCO; 48-Bit Programmable Symbol Timing NCOs
- Dynamic Gain Profiling and Output Routing Control

**Applications**

- Single or Multiple Channel Digital Software Radio Transmitters (Wide-Band or Narrow-Band)
- Base Station Transmitter and Smart Antennas
- Operates with HSP50216 in Software Radio Solutions
- Compatible with the HI5960/ISL5961 or HI5828/ISL5929 D/A Converters

**Ordering Information**

| PART NUMBER  | TEMP RANGE (°C) | PACKAGE        | PKG. NO    |
|--------------|-----------------|----------------|------------|
| ISL5217KI    | -40 to 85       | 196 Ld BGA     | V196.15x15 |
| ISL5217EVAL1 | 25              | Evaluation Kit |            |

**Block Diagram**

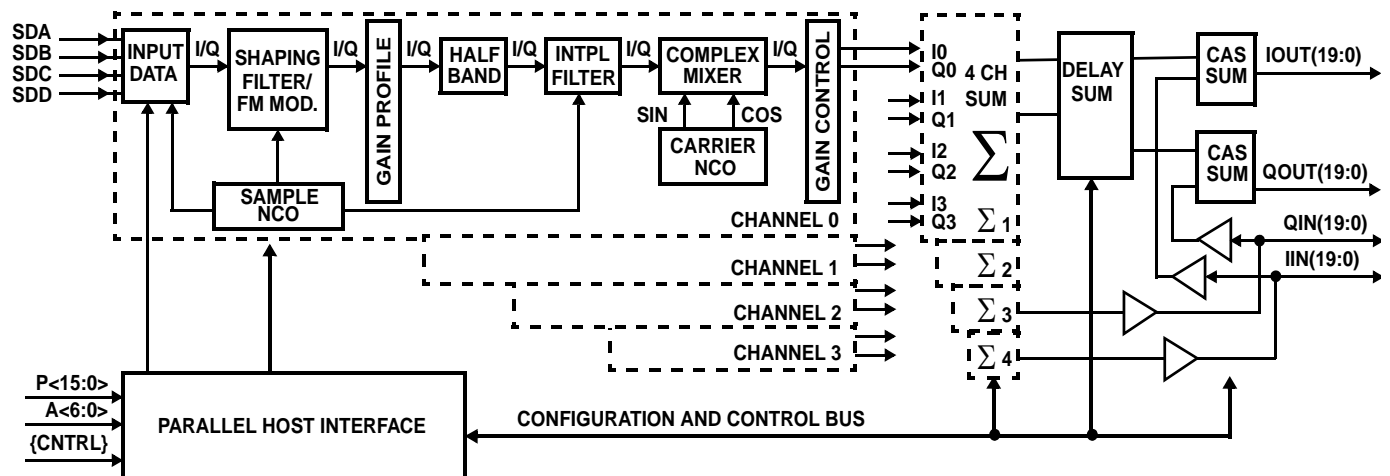

# Functional Block Diagram

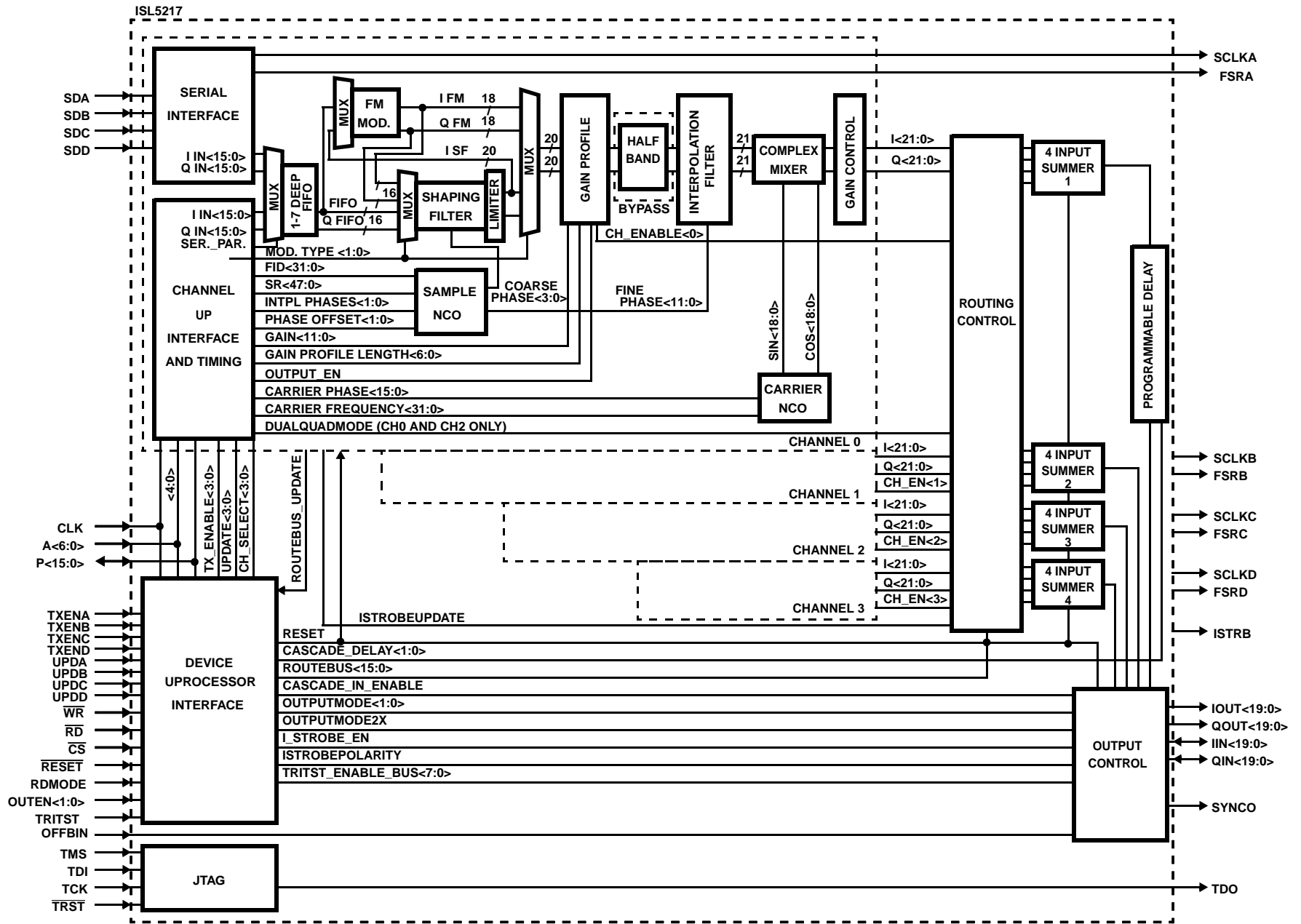

Pinout

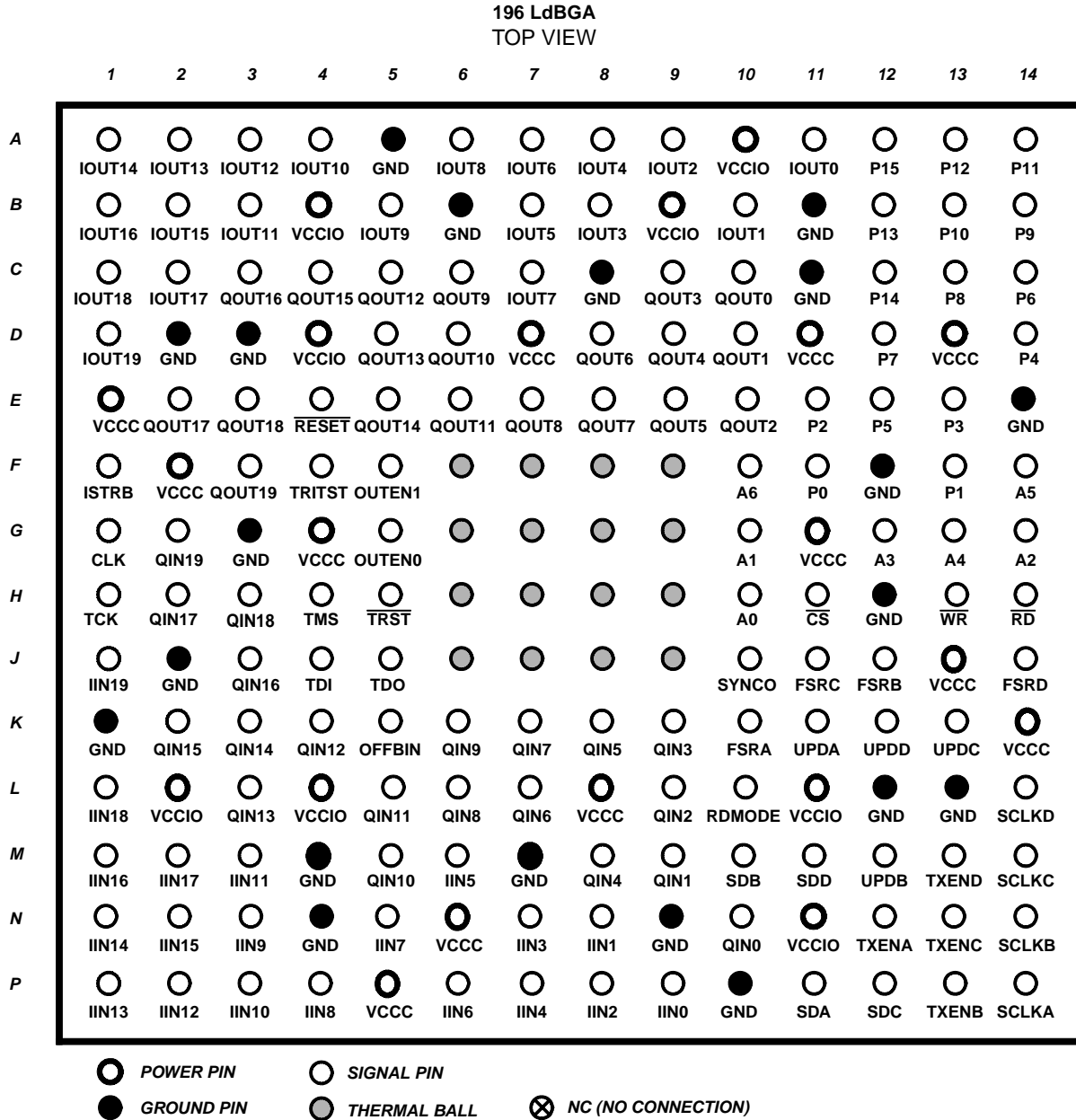

**NOTE:**  
Thermal balls should be connected to the ground plane.

**Pin Descriptions (all signals are active high unless otherwise stated)**

| NAME   | TYPE | DESCRIPTION  |
|--|------|--|
| <b>POWER SUPPLY</b>                                  |      |  |
| VCC  | -    | Positive Device Core Power Supply Voltage, 2.5V $\pm$ 0.125V.  |
| VCCIO  | -    | Positive Device Input/Output Power Supply Voltage, 3.3V $\pm$ 0.165V.  |
| GND  | -    | Ground, 0V   |
| <b>MICROPROCESSOR INTERFACE AND CONTROL</b>          |      |  |
| CLK  | I    | Input Clock. All processing in the ISL5217 occurs on the rising edge of CLK.   |
| $\overline{\text{RESET}}$                            | I    | Reset. (Active Low). Asserting reset will clear all configuration registers to their default values, halting all processing.   |
| P<15:0>  | I/O  | Data bus. Bit 15 is the MSB.   |
| A<6:0>   | I    | Address bus. Bit 6 is the MSB.   |
| $\overline{\text{CS}}$                               | I    | Chip Select. (active low). Enables device to respond to $\mu$ P access. <b>NOTE: See Appendix A, Errata Sheet.</b>   |
| RDMODE   | I    | Read Mode. Read mode selects the Read/Write mode for the Microprocessor Interface. When low the device is configured for separate $\overline{\text{RD}}$ and $\overline{\text{WR}}$ strobe inputs. When high the device is configured for a common Read/Write and Data Strobe inputs. Internally pulled down.  |
| $\overline{\text{WR}}$                               | I    | Write Strobe, (active low). Dual function input. The input is configured for Write Strobe when RDMODE is low. When RDMODE is high the input is configured for Data Strobe.<br>Write Strobe. The data on P<15:0> is written to the destination selected by A<6:0> on the rising edge of $\overline{\text{WR}}$ when $\overline{\text{CS}}$ is asserted (low).<br>Data Strobe. The data on P<15:0> is written to the destination selected by A<6:0> on the rising edge of Data strobe when $\overline{\text{RD}}$ is low and $\overline{\text{CS}}$ is asserted (low) or read from the address selected by A<6:0> placed on P<15:0> when $\overline{\text{RD}}$ is high and $\overline{\text{CS}}$ is asserted (low).  |
| $\overline{\text{RD}}$                               | I    | Read Strobe (Active Low). Dual function input. The input is configured for Read Strobe when RDMODE is low. When RDMODE is high the input is configured for Read/Write Strobe.<br>Read Strobe. The data at the address selected by A(6:0) is placed on P<15:0> when $\overline{\text{RD}}$ is asserted (low) and $\overline{\text{CS}}$ is asserted (low).<br>Read/Write Strobe. Determines the type of $\mu$ P access.   |
| OFFBIN   | I    | Offset Binary. When set to 1, the output data bus format is offset binary. When set to 0 the output data bus format is 2's complement.   |
| OUTEN<1:0>   | I    | Output Three-state Control. OUTEN<1:0> is decoded to provide three-state control of the output data buses. When TRITST is asserted, the three-state control divides the 80-bit output into eight groups of 10-bits each. When TRITST is deasserted, the three-state control operates on the 20-bit real and imaginary cascade out data buses.  |
| TRITST   | I    | Tester Three-State Control. This signal determines how the OUTEN<1:0> is decoded to provide the necessary three-state controls when in normal or tester applications. Set low for normal operation.  |
| <b>SERIAL DATA / SYNCHRONIZATION AND FIFO STATUS</b> |      |  |
| SDA, SDB, SDC, SDD                                   | I    | Serial Data A-D. (SDX) Serial Data Input for the I and Q vectors. The processing channel selected for this data will shift the data in on the rising edge of its serial TX clock. The data vectors are shifted in with the MSB first.  |
| SCLKA, SCLKB, SCLKC, SCLKD                           | O    | SERIAL CLK A-D. (SCLKX) Dual function output. The output is SERIAL CLK when symbol data is input through the serial data port. When symbol data is input through the $\mu$ P port the output is SAMPLE CLK 0-3. The polarity of SCLKX is programmable.<br>Serial Clock. Programmable rate clock signal provided to the data source to shift serial data out. Programmed rates can be CLK/(1-32), or 32x sample clock. See control word 0x17, bit 15 for shut-off conditioning.<br>SAMPLE CLK. Signal provided to the data source to indicate when data is being transferred from the FIFO to the shaping filter. The SAMPLE CLK output is generated by the sample rate NCO and has approximately 50% duty cycle. The sample is taken on the high-to-low transition.  |
| FSRA, FSRB, FSRC, FSRD                               | O    | FRAME STROBE A-D. (FSRX) Multiple Function Output. When control word 0x0c, bit 11 is set to zero, the output is FRAME STROBE when symbol data is input through the serial data port. When symbol data is input through the $\mu$ P port the output is FIFO READY 0-3. When control word 0x0c, bit 11 is set to one, the setting of the FSRMode<1:0> bits in indirect address 0x407 determine the output. The polarity of FSRX is programmable.<br>FRAME STROBE. Signal provided to the data source to initiate a serial word transfer. Alternatively selectable through Serial Control 0x11, bit 14 to be Epoch frame strobe. Epoch is a pre-carry out of the fixed integer divider instead of the serial frame strobe. The Epoch pre-carry out is six clocks ahead of the true carry out and can be used to synchronize fixed integer dividers of other devices. See control word 0x17, bit 15 for shut-off conditioning.<br>FIFO READY. Indicates the I and Q FIFO pointer is less than the programmed FIFO depth.<br>UPDX or TXENX. When 0x0c, bit 11 is set to one, and FSRMode<1:0> is set to 10, the internal channel UPDX is output. When 0x0c, bit 11 is set to one, and FSRMode<1:0> is set to 11, the internal channel TXENX is output. See Table 43 for additional details. |

**Pin Descriptions (all signals are active high unless otherwise stated)** (Continued)

| NAME                                | TYPE | DESCRIPTION   |
|-------------------------------------|------|---|
| TXENA,<br>TXENB,<br>TXENC,<br>TXEND | I    | Transmit Enable A-D. (TXEN $\bar{X}$ ) The processing channel selected for this enable will force a channel flush (conditioned by control word 0x0c, bit 2), clear the data RAMs, and update the selected configuration registers upon assertion. No additional requests for serial data will be made when TXEN $\bar{X}$ is deasserted, unless conditioned by control word 0x0c, bit 3. The polarity of TXEN $\bar{X}$ is programmable. Optionally, TXEN $\bar{X}$ can be internally generated with a programmable duty cycle. Two different programmable TXEN $\bar{X}$ cycles can be programmed and toggled between based on programmed cycle length. See control word 0x0c, bit 11 and Table 43 for additional details. |
| UPDA, UPDB,<br>UPDC, UPDD           | I    | Update A-D. (UPD $\bar{X}$ ) The processing channel selected for this input updates the selected configuration registers, if the associated update mask bit is set. The polarity of UPD $\bar{X}$ is programmable.  |
| SYNCO                               | O    | Synchronization Output. The processing of multiple ISL5217 devices can be synchronized through software by connecting the SYNCO of the master ISL5217 device to an UPD $\bar{X}$ pin of the ISL5217 slaves. The polarity of SYNCO is programmable.  |
| <b>MODULATED DATA (80)</b>          |      |   |
| IOUT(19:0)                          | O    | Output Data Bus A (19:0). Output bus A contains the digital modulated QUC output samples from Output Summer/Formatter 1. The samples are updated on the rising edge of the CLK. Bit <19> is the MSB.  |
| QOUT(19:0)                          | O    | Output Data Bus B (19:0). The output bus contains the digital modulated QUC output samples from Output Summer/Formatter 2. The samples are updated on the rising edge of the CLK. Bit <19> is the MSB.  |
| IIN(19:0)                           | I/O  | I Cascade In (19:0) or OUTPUT BUS C. Dual function I/O bus. The bus is configured for input when the output mode is cascade in. The bus is configured for output for all other output modes.<br>I Cascade In. Input bus allows multiple parts to be cascaded by routing the digital modulated signal I CAS OUT, (Bus A), from one QUC into Output Summer/Formatter 1 of a second QUC. I CAS IN (19:0) is in 2's complement format and is sampled on the rising edge of CLK. Bit<19> is the MSB.<br>Output Data Bus C. The output bus contains the digital modulated QUC output samples from Output Summer/Formatter 3. The samples are updated on the rising edge of the CLK. Bit <19> is the MSB.                          |
| QIN(19:0)                           | I/O  | Q Cascade in (19:0) or Output Data Bus D. Dual function I/O bus. The bus is configured for input when the output mode is cascade in. The bus is configured for output for all other output modes.<br>Q Cascade in. Input bus allows multiple parts to be cascaded by routing the digital modulated signal Q CAS OUT, (Bus B), from one QUC into Output Summer/Formatter 2 of a second QUC. Q CAS IN (19:0) is in 2's complement format and is sampled on the rising edge of CLK. Bit<19> is the MSB.<br>Output Data Bus D. The output bus contains the digital modulated QUC output samples from Output Summer/Formatter 4. The samples are updated on the rising edge of the CLK. Bit <19> is the MSB.                     |
| ISTRB                               | O    | I data strobe. (active high). Used in the muxed I/Q mode. When asserted, the output data buses contain valid I data.  |
| <b>JTAG TEST ACCESS PORT</b>        |      |   |
| TMS                                 | I    | JTAG Test Mode Select. Internally pulled up.  |
| TDI                                 | I    | JTAG Test Data In. Internally pulled up.  |
| TCK                                 | I    | JTAG Test Clock.  |
| $\overline{\text{TRST}}$            | I    | JTAG Test Reset (Active Low). Internally pulled-up. This pin should be driven by the JTAG logic to obtain a TAP controller reset, or if JTAG is not utilized, this pin should be tied to ground for normal operation. As recommended in the 1149.1 standard documentation the $\overline{\text{TRST}}$ test pin should be made active soon after power-up to guarantee a known state within the TAP logic on the ISL5217. This avoids potential damage due to signal contention at the circuit's inputs and outputs.  |
| TDO                                 | O    | JTAG Test Data Out.   |

## Functional Description

The ISL5217 Quad Programmable UpConverter (QPUC) converts digital baseband data into modulated or frequency translated digital samples. The QPUC can be configured to create any quadrature amplitude shift-keyed (QASK) data modulated signal, including QPSK, BPSK, and m-ary QAM. The QPUC can also be configured to create both shaped and unfiltered FM signals. A minimum of 16 bits of resolution is maintained throughout the internal processing.

The QPUC is configured via the microprocessor data bus, using the  $A<6:0>$  address bus,  $P<15:0>$  data bus,  $\overline{RD}$ ,  $\overline{WR}$  and  $\overline{CS}$  control signals. Configuration data that is loaded via this bus includes the individual channel's 48-bit Sample Rate NCO center frequency, the 32-bit Carrier NCO center frequency, the device modulation format, gain control, input mode control, reset control and sync control. The I and Q baseband channels each have a 256 tap FIR filter whose coefficients and configuration are also programmed via the  $\mu P$  interface. Similarly, the control signals for the I and Q channel interpolation filters are programmed via the  $\mu P$  interface. Discussion in the following sections utilizes the register definitions for channel 0. Channels 1-3 are similarly configured in accordance with the Table 10 Memory Map.

## Data Input

The I/Q sample pairs can be input serially through 1 of 4 serial interfaces or in parallel through the  $\mu P$  addressable registers as shown in Figure 1.

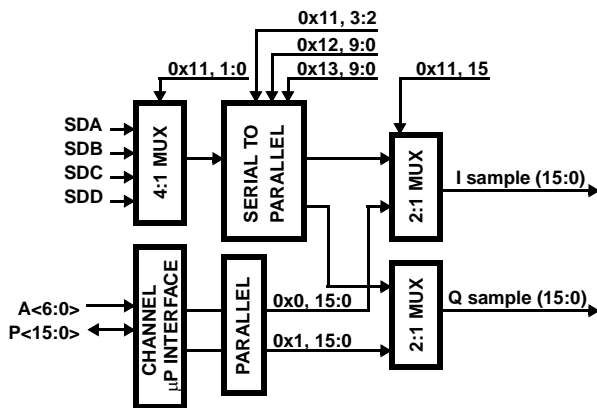

FIGURE 1. SINGLE CHANNEL DATA INPUT PATH

## Serial

The serial mode allows the device to shift the I and Q samples serially into the FIFO holding registers. The serial input format is selected when Serial control (0x11, bit 15) is high. The serial interface is three-wire interface controlled by the channel. The serial clock and frame strobe are driven by the channel to clock the serial data from the source into the serial data port. The serial clock can operate at the clock rate, at a divided clock rate, or be driven at 32x the sample clock rate. Serial control (0x11, bits 13:8) configure the serial clock. In the 32x mode, back

16-bit serial transfers can occur by setting control word (0x17, bits 14:13) both high. The serial process begins with the first serial clock after the start of a sample clock. The frame strobe is asserted for one serial clock and starts the I and Q time slot counters. The TXEN $\overline{X}$  pin or Main control (0x0c, bit 0) S/W TX enable must be asserted to enable the frame strobe out. Additional requests for serial data, with TXEN $\overline{X}$  de-asserted, are controlled by bit 3 of control word 0x0c. The serial interface may be programmed to be dependent or independent of TXEN $\overline{X}$  control. The I and Q time slot counters, programmed through 0x12, bits 9:0 and 0x13, bits 9:0, control the duration of the serial to parallel conversion of the serial data input. The counters are loaded to count the number of serial clocks from the frame strobe to shift in the last data bit of that sample. The time slot counters are 10-bits to allow multiple channels to share a common serial data input. The MSB is always shifted first, but the order of the I and Q serial data is flexible due to the variability of the time slot counters. The received serial word is MSB justified prior to loading into the FIFO holding register based on the serial word length, programmed through Serial control (0x11, bits 3:2) to 4, 8, 12, or 16 bits.

Although each channel has control of a serial interface it may select serial data from one of the other interfaces. Serial control (0x11, bits 1:0) selects 1 of 4 serial data ports for the channel. The serial data transfer format is shown in Figure 2.

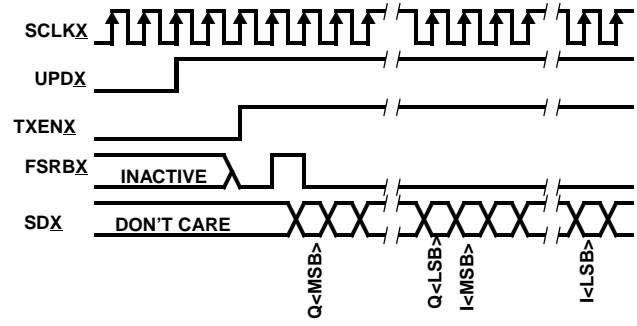

FIGURE 2. SERIAL DATA TRANSFER

The ability to select the serial input source allows multiple QPUCs to share a single microprocessor interface with their processing synchronized through the master QPUC SYNCO being tied to the slave device UPD $\overline{X}$ . Conversely, multiple



microprocessors can share a single QPUC as shown in Figure 3.

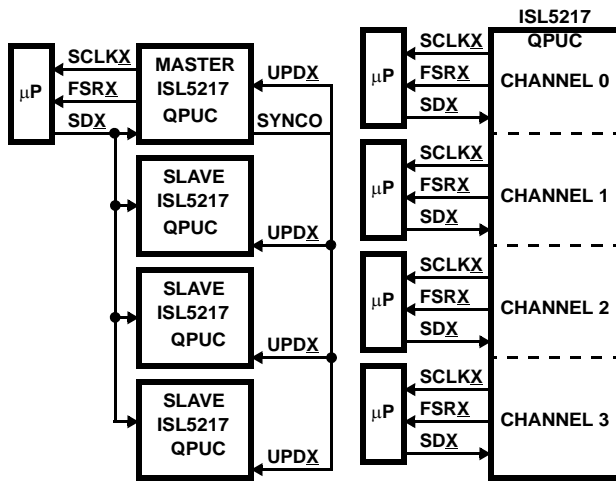

FIGURE 3. MULTIPLE CONFIGURATIONS

### Parallel

The parallel mode allows the  $\mu\text{P}$  to write the I and Q samples directly to the FIFO holding registers. The parallel input format is selected when Serial control (0x11, bit 15) is low. The normal  $\mu\text{P}$  write order is the Q sample, Control word 0x1, followed by the I sample, Control word 0x0. Writing to Control word 0x0 generates the update strobe to move the data from the FIFO holding register into the first location of the I/Q FIFO. The first location of the I/Q FIFO is available for read back. The  $\mu\text{P}$  can perform back-to-back write accesses to Control words 0x1 and 0x0, but must maintain four  $f_{\text{CLK}}$  periods between accesses to the same address. This limits the maximum  $\mu\text{P}$  write access rate for an I/Q sample pair to  $104\text{MHz}/4 = 26\text{MHz}$ . The Read/Write format for a parallel data transfer is shown in Figure 4

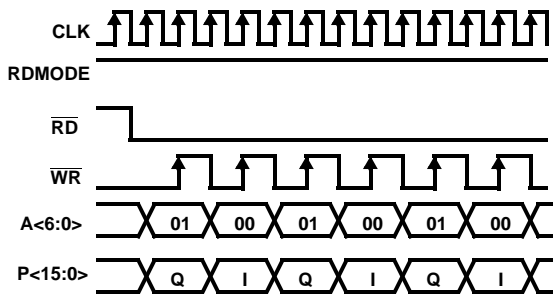

FIGURE 4. PARALLEL DATA TRANSFER

### FIFO

The FIFO provides the interface and data storage between the input source and the shaping filter or FM modulator. The FIFO can hold up to seven I/Q sample pairs. The block diagram is shown in Figure 6.

The input source to the FIFO is selected by Serial control (15). The FIFO pointer is incremented every time data is written into the FIFO. The transferring of data into the FIFO does not occur until both I and Q have been received when the sample data is input in a serial fashion. When the sample data is input in a parallel fashion, the transferring of data into the FIFO occurs when the  $\mu\text{P}$  writes to Control Word 0 (I data).

While the input source determines the write rate, the shaping filter determines the read rate. The maximum read rate occurs when the shaping filter constraints for Data Span (DS) and Interpolation Phases (IP) equal four. For a clock rate of 104MHz, the maximum read rate is determined by  $f_{\text{CLK}}/(\text{DS})(\text{IP})$ , which is  $104\text{MHz}/16 = 6.5\text{MHz}$ . See the Shaping Filter Section for more details. When the Shaping Filter requires another data sample, a request is made to the FIFO for data and the FIFO pointer is decremented. Figure 5 indicates the timing of a request for data from the Shaping filter to the actual appearance of data at the FIFO output. An "empty" FIFO detection causes zero valued data to be entered into the shaping filter. The FIFO can be forced to enter zero valued data by setting the on-line mode to false. The on-line mode is enabled by Main control (0xc, bit 6). A "full" FIFO detection prevents data from being pushed out of the FIFO before the filter requests it. Writing to a full FIFO is treated as an error condition that will result in a soft reset of the channel to prevent transmission of erroneous data over the air. The full FIFO channel reset can be disabled by control word 0x0c, bit 1.

A programmable FIFO depth threshold sets when the FIFORDY signal is asserted, alerting the data source that more data is required. The FIFORDY signal assists the data source in maintaining the desired FIFO data depth. The data FIFO depth threshold for both I and Q inputs is set by Main control (0xc, bits 10:8). The SAMPLE CLK may be used instead of FIFORDY to indicate when data has been transferred from the FIFO to the shaping filter. See the pin description table for additional details and Figure 5 for the input data latency.

### Data Modulation Path

Three data path options are provided, one for each modulation format. The modulation format is selected using FIR Control (0xd, 3:2). The modulation paths are defined in the following subsections.

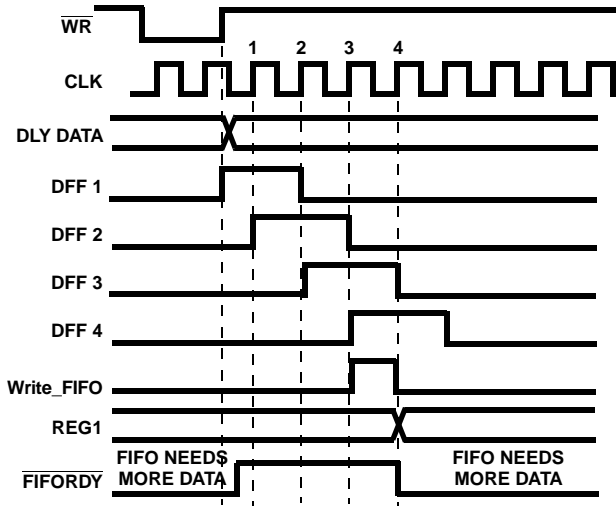
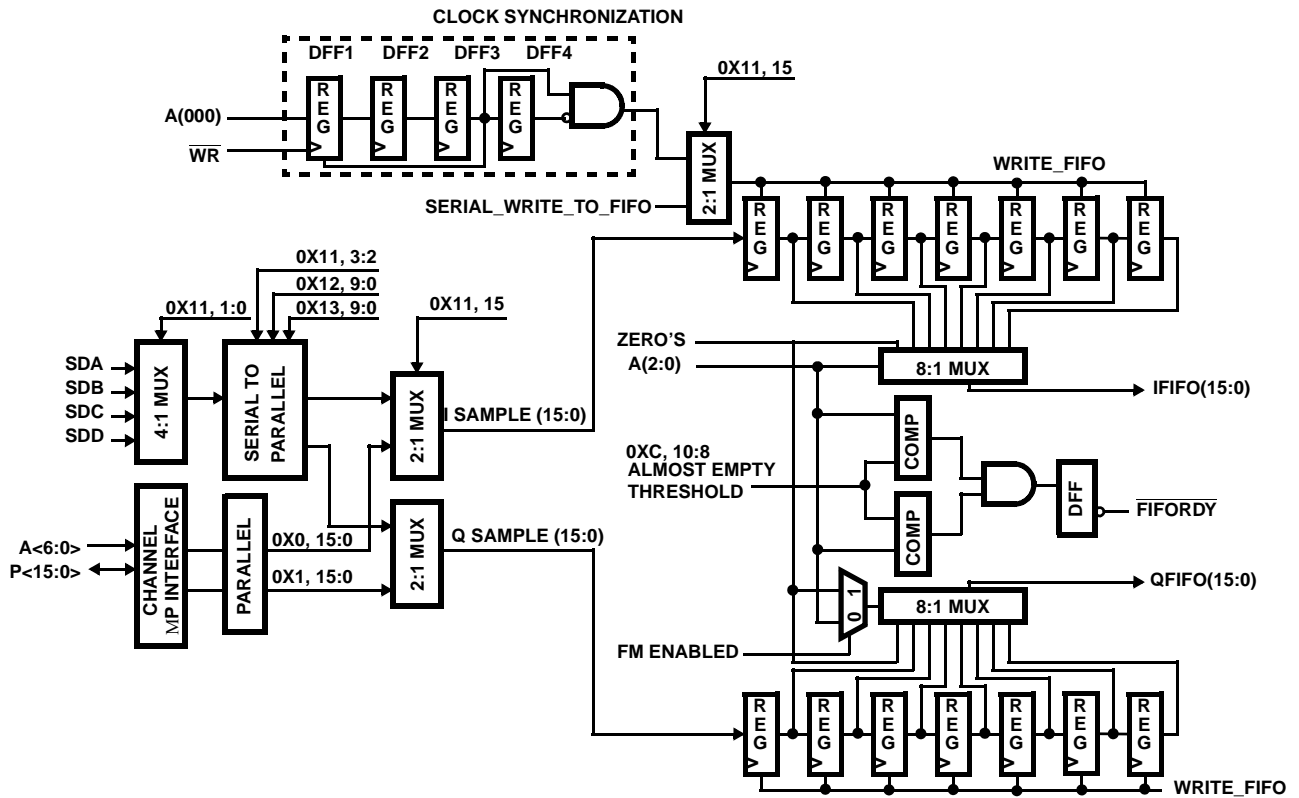

FIGURE 5. FIFO DATA AND ENABLE TIMING



† All Registers are clocked at CLK unless shown otherwise.

FIGURE 6. I AND Q FIFO BLOCK DIAGRAM



**Modulation Mode 00 - QASK**

This modulation mode configures the QPUC as a BPSK, QPSK, OQPSK, MSK or m-QAM modulator. The block diagram is shown in Figure 7. The data FIFO outputs are routed to the shaping filters. Here the samples are interpolated by 4, 8, or 16 and shaped using a FIR filter with up to a 256 taps. The filter impulse response can span 4-16 input samples. A half (input) sample delay can be inserted in the I/Q path after the FIR and is enabled through Main Control (0xc, bit 13). The 20-bit output of the shaping filter is routed through a gain adjust multiplier controlled by 0x0a, bits 11:0 and into the interpolation filter. The interpolation filter interpolates by a factor set in the resampling NCO with the Interpolation Phases controlled by 0xd, bits 1:0. The output of the interpolation filter is at the master clock frequency, CLK. The samples are then mixed with the carrier L.O. for quadrature upconversion. The output is then summed with the cascade input signal, saturated (in the case of overflow), and formatted for output.



FIGURE 7. QASK

**Modulation Mode 01 - FM with Bandlimiting Filter**

This mode configures the QPUC as an FM modulator with post-modulation filtering. The block diagram is shown in Figure 8. This mode provides for FSK and FM modulation schemes. In this mode, the I input samples drive the frequency control section of a quadrature NCO to produce a zero IF FM signal. The 16-bit FM quadrature signals are then routed to the shaping FIR filter and into the interpolation filter for bandlimiting and interpolation up to the master clock rate. The quadrature filtered FM signals are then upconverted to the carrier frequency by the carrier NCO and mixers. The output is then summed with the cascade input signal, saturated (in the case of overflow), and formatted for output. Note that pulse shaping in this mode must be provided prior to the QPUC.

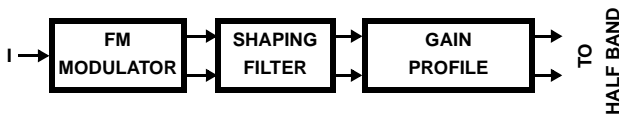

FIGURE 8. FM WITH BANDLIMITING

**Modulation Mode 10 - FM with Pulse Shaping**

This mode configures the QPUC as a FM modulator with pre-modulation baseband pulse shaping. The block diagram is shown in Figure 9. The data from the FIFO (I channel only) is routed to the FIR shaping filter. The FIR shaping filter output drives the frequency control section of a quadrature NCO to produce a zero IF FM signal. These 18-bit FM

modulated quadrature samples are then up sampled in the interpolation filter to the output sample rate. The baseband modulated signal is then upconverted to the carrier frequency by the carrier NCO and mixers. The output is then summed with the cascade input signal, saturated, and formatted for output.

In Mode 10, the amplitude out of the shaping filter needs to be limited in order to prevent frequency excursions that cannot be filtered out in the interpolation filter.

**NOTE: THE QUALITY OF THE FM SIGNAL IS AFFECTED BY THE AMPLITUDE SLEW RATE OUT OF THE SHAPING FILTER. AS A RULE OF THUMB, LIMITING THIS SLEW RATE TO LESS THAN 1/8 THE SAMPLE RATE WILL MINIMIZE THIS DISTORTION.**

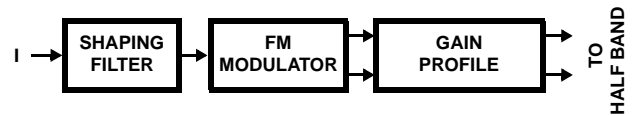

FIGURE 9. FM WITH PULSE SHAPING

**FM Modulator**

The FM modulator provides for frequency modulation of the carrier center frequency by the QPUC input data. The FM modulator is driven either directly by the QPUC I input (Mode 01) or by the output of the FIR shaping filter (Mode 10). The input data to the FM Modulator, is defined as  $d\phi(n)/dt$ , where  $\phi(nT)$  is the phase of a theoretical sinusoid described by:

$$s(n) = A (\cos[\phi(nT)] + j \sin [\phi(nT)]); A \approx 1 \text{ in Modulator (EQ. 1)}$$

The block diagram is shown in Figure 10. The input to the FM modulator,  $d\phi(n)/dt$ , is integrated via the NCO accumulator. The NCO accumulator output represents phase and is used to address a SIN/COS generator, synthesizing a sinusoid of the form described in Equation 1. The phase accumulator feedback of the NCO is 20 bits and 18 bits of the phase word are routed to the SIN/COS generator. Eighteen bits of amplitude are provided on the Sine and Cosine outputs.

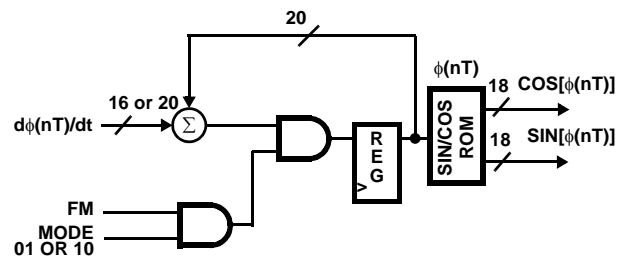

FIGURE 10. FM MODULATOR BLOCK DIAGRAM

The transfer function of the FM modulator is defined by the change in degrees per sample value,  $d\phi(nT)/dt$ , where  $d\phi(nT)/dt$  is a 16-bit, twos complement, fractionally notated frequency control word with a range from  $-F_{SAMP}/2$  to  $+F_{SAMP}/2$ .  $F_{SAMP}$  is defined as the sample rate into the FM

modulator. The maximum phase step that can occur in one clock is  $\pm 180$  degrees. Table 1 provides the change in phase weighting of the input bits.

TABLE 1. PHASE WEIGHTING

| $d\phi(nT)/dt$      | DEGREES/SAMPLE |
|---------------------|----------------|
| 1000 0000 0000 0000 | -180           |
| 0000 0000 0000 0000 | 0              |
| 0111 1111 1111 1111 | ~+180          |

### Shaping Filter

The shaping filter provides the necessary pulse shaping required on the input data to implement various QASK and shaped FM modulation formats. Two identical shaping filters (one each for the I and Q paths) are provided. The shaping filter architecture uses a NCO controlled interpolating FIR, capable of 4, 8, or 16 interpolation phases. The number of interpolation phases, (IP) is loaded into FIR Control (0xd, bits 1:0). The span of the impulse response of the polyphase filter can vary from 4-16 data samples. The desired sample Data Span, (DS) value minus one is loaded into FIR Control (0xd, bits 7:4). Thus, the required number of coefficients (or filter span) becomes:

$$\# \text{ Coefficients} = (DS)(IP) \quad (\text{EQ. 2})$$

The Interpolation Phase also determines the rate to compute a polyphase output by selecting the appropriate timing from the Sample Rate NCO to drive the shaping filter at 4x, 8x, or 16x the input sample rate. The Data Span selects the number of samples to convolve. Each convolution requires DS reference clocks for each phase of the filter. An output is calculated (IP) times for each input sample. To allow sufficient processing time for each output, the reference clock must be as follows:

$$CLK \geq (DS)(IP)(f_S) \quad (\text{EQ. 3})$$

Conversely, the input sample rate requires:

$$f_S \leq f_{CLK} / [(IP)(DS)] \quad (\text{EQ. 4})$$

where  $f_{CLK}$  is the frequency of the reference clock, IP is the shaping filter interpolate rate; and DS is the number of data samples in the filter span. For example, if  $f_{CLK} = 104\text{MHz}$ , the filter span is 16 samples, and the interpolation rate is 16, then the maximum input sample rate,  $f_S$  is  $104/256 = 406.25\text{kHz}$ . Table 2 shows several examples of calculations for FIR input sample rates based on master reference clock rate, number of data samples, and interpolation rate. The data exits the shaping filters at the interpolated rate.

TABLE 2. EXAMPLE CALCULATIONS

| EXAMPLE | $f_{CLK}$ | DS | IP | MAX $f_S$                    |
|---------|-----------|----|----|------------------------------|
| 1       | 104MHz    | 16 | 16 | $104/256 = 406.25\text{kHz}$ |
| 2       | 104MHz    | 16 | 8  | $104/128 = 812.5\text{kHz}$  |
| 3       | 104MHz    | 16 | 4  | $104/64 = 1.625\text{MHz}$   |
| 4       | 104MHz    | 10 | 4  | $104/40 = 2.600\text{MHz}$   |
| 5       | 104MHz    | 8  | 4  | $104/32 = 3.250\text{MHz}$   |
| 6       | 104MHz    | 4  | 4  | $104/16 = 6.500\text{MHz}$   |

The shaping filters have programmable coefficients which must be loaded via the microprocessor interface. The QPUC supports loading coefficients for two shaping filters, with FIR Control (0xd, bit 8) selecting the active filter. The I and Q shaping filters are identical and may be loaded simultaneously or separately, allowing for different gains and responses through the filter if desired.

TABLE 3. FIR CONTROLS

| IP | STARTING ADDRESS W/FIR CONTROL (8) = '0' | STARTING ADDRESS W/FIR CONTROL (8) = '1' |
|----|--|--|
| 4  | 0  | 8  |
| 8  | 0  | 8  |
| 16 | 0  | 128                                      |

Because 16 interpolation phases are possible, the coefficients are structured in sets of 16, one set for each phase of the shaping filter. The convolution algorithm sequentially steps through each of these phases, beginning with phase 0. The coefficients for the shaping filters are generated by designing the prototype filter at the interpolated rate. The coefficients are then divided into interpolation phases by taking every  $n^{\text{th}}$  tap of the prototype filter and storing the coefficient as an element of a coefficient set. The IP value determines the addressing interval through the prototype filter to create the coefficient sets for the filter phases. The first coefficient set begins at address 0. The next coefficient set begins at address 1 and continues in a like manner for the remaining coefficient sets. For a 16 tap, interpolate-by-4 filter, the calculations for filter 1 are:

$$\text{Polyphase output 0} = (C0 * D[n]) + (C4 * D[n-1]) + (C8 * D[n-2]) + (C12 * D[n-3])$$

$$\text{Polyphase output 1} = (C1 * D[n]) + (C5 * D[n-1]) + (C9 * D[n-2]) + (C13 * D[n-3])$$

$$\text{Polyphase output 2} = (C2 * D[n]) + (C6 * D[n-1]) + (C10 * D[n-2]) + (C14 * D[n-3])$$

$$\text{Polyphase output 3} = (C3 * D[n]) + (C7 * D[n-1]) + (C11 * D[n-2]) + (C15 * D[n-3])$$

If FIR Control (8) is set the calculations for filter 2 are:

$$\text{Polyphase output 0} = (D0 * D[n]) + (D4 * D[n-1]) + (D8 * D[n-2]) + (D12 * D[n-3])$$

$$\text{Polyphase output 1} = (D1 \cdot D[n]) + (D5 \cdot D[n-1]) + (D9 \cdot D[n-2]) + (D13 \cdot D[n-3])$$

$$\text{Polyphase output 2} = (D2 \cdot D[n]) + (D6 \cdot D[n-1]) + (D10 \cdot D[n-2]) + (D14 \cdot D[n-3])$$

$$\text{Polyphase output 3} = (D3 \cdot D[n]) + (D7 \cdot D[n-1]) + (D11 \cdot D[n-2]) + (D15 \cdot D[n-3])$$

Table 4 details the coefficient address allocation for the previous example. The interpolation phase is on the left and the data span is across the top. The coefficient RAM address followed by the coefficient term is listed in the table's cell. Table 49 details the coefficient address locations through 255.

TABLE 4. ADDRESS ALLOCATION

|      | DS [n] | DS [n-1] | DS [n-2] | DS [n-3] |   |
|------|--------|----------|----------|----------|---|
| IP0  | 0 CO   | 16 C4    | 32 C8    | 48 C12   | • |
| IP1  | 1 C1   | 17 C5    | 33 C9    | 49 C13   | • |
| IP2  | 2 C2   | 18 C6    | 34 C10   | 50 C14   | • |
| IP3  | 3 C3   | 19 C7    | 35 C11   | 51 C15   | • |
| IP4  | 4      | 20       | 36       | 52       | • |
| IP5  | 5      | 21       | 37       | 53       | • |
| IP6  | 6      | 22       | 38       | 54       | • |
| IP7  | 7      | 23       | 39       | 55       | • |
| IP8  | 8 D0   | 24 D4    | 40 D8    | 56 D12   | • |
| IP9  | 9 D1   | 25 D5    | 41 D9    | 57 D13   | • |
| IP10 | 10 D2  | 26 D6    | 42 D10   | 58 D14   | • |
| IP11 | 11 D3  | 27 D7    | 43 D11   | 59 D15   | • |
| IP12 | 12     | 28       | 44       | 60       | • |
| IP13 | 13     | 29       | 45       | 61       | • |
| IP14 | 14     | 30       | 46       | 62       | • |
| IP15 | 15     | 31       | 47       | 63       | • |

The loading options are programmable including read back modes and are discussed in detail in the 'Microprocessor Interface' section. Both 16-bit 2's complement and 24-bit floating point format are allowed. The 2's complement coefficient format of valid digital values ranges from 0x8001 to 0x7FFF. The value 8000 is not allowed. The 24-bit floating point (20-bit mantissa with 4-bit exponent) mode allows an exponent range from 0 to 15. An exponent of 0 indicates multiplication of the coefficient by  $2^0$ , and an exponent of 1 is  $2^{-1}$ , down to a value of 15 being  $2^{-15}$ . The default mode is 2's complement, with 24-bit floating point mode enabled by setting control word (0x17, bit 12).

The gain through the filter is:

$$A = (\text{sum of coefficients}) / \text{interpolation rate.}$$

The shaping filter contains saturation logic in the event that the final output peaks over +/- 1.0. When using quadrature modulation, saturation/overflow can occur when the input values for I and Q exceed 0.707 peak. The shaping filter coefficients may need to be reduced from full scale to prevent saturation.

### Gain Profile

The overall channel gain is controlled by both a gain profile stage and a gain control stage, which provide identical scaling for the I and Q upconverted data. The gain profile stage allows transmit ramp-up and quench fading, to control the sidelobe profile in burst mode. This is implemented through user control of the rise and fall transitions utilizing a gain profile memory. The gain profile memory is a 128 x 12 bit RAM which is loaded with the desired scaling coefficients via indirect addressing of memory spaces 0x000-0x07f. The pulse shaping is implemented by linearly multiplying the programmed coefficient by the shaping filter outputs at the  $f_s \cdot IP$ , or coarse phase rate. The gain profile is enabled by FIR control (0xd, bit 15), with the RAM address pointer being reset to zero on assertion of the gain profile enable. Control of the pulse shaping is based on TXEN $\bar{X}$ , as the TXEN $\bar{X}$  rising edge causes the RAM pointer to begin stepping through the profile until the RAM pointer matches the Gain profile length programmed into control word (0x0b, bits 6:0). The falling edge of TXEN $\bar{X}$  reverses the process and the RAM pointer begins decrementing until it reaches zero. The gain process is symmetric with respect to the rising or falling edges of TXEN $\bar{X}$ . The latency through the gain profile block is set by control word (0x0b, bits 8:7) where bit 8 bypasses all latency alignment circuitry and uses TXEN $\bar{X}$  as input to the channel. Setting control word (0x0b, bit 7) removes two edge latencies from the delay path and should be combined with selection of DS = 3, IP = 4 in order to have perfect symmetry through the gain profile block. The memory coefficients may be loaded without taking the channel off-line. This is implemented by setting the gain profile hold bit in control word (0x0c, bit 14) which holds the last gain value and provides access to the memory.

The gain profile coefficients are programmed as unsigned values:

$$\text{Bit weight } 2^0 \cdot 2^{-1} \cdot 2^{-2} \dots 2^{-11}$$

$$\text{Maximum } 0x800 = 1.0$$

$$0x001 = 2^{-11}$$

$$\text{Minimum } 0x000 = 0.0$$

## Gain Control

The gain control is implemented through a scaling multiplier followed by a scaling shift. The combination of the multiplier and shifter provide the final output gain of the channel. Gain adjustment can vary from -0.0026 to -144 dBFS.

Given a desired attenuation, the scaling multiplier value,  $\text{Gain}_{\text{MULT}}(11:0)$  can be calculated by the following equation.

$$\text{Gain}_{\text{MULT}}(11:0) = \text{INT} [10^{(|\text{Gain}(\text{db})| / 20)} 2^{12}]$$

where  $\text{INT}[X]$  is the integer part of the real number  $X$ .

Table 5 details a few scaling multiplier values and their associated attenuations.

**TABLE 5. SCALING GAIN ATTENUATION**

| $\text{GAIN}_{\text{MULT}}$<br>(0xa, 11:0) | GAIN (dBFS) | SCALING GAIN<br>( $V_{\text{OUT}}/V_{\text{IN}}$ )% |
|--|-------------|---|
| 1111 1111 1111                             | -0.0026     | 99.97   |
| 1000 0000 0000                             | -6.021      | 50.0  |
| 0100 0000 0000                             | -12.041     | 25.0  |
| 0010 0000 0000                             | -18.062     | 12.5  |
| 0001 0000 0000                             | -24.082     | 6.25  |
| 0000 1000 0000                             | -30.103     | 3.125   |
| 0000 0100 0000                             | -36.124     | 1.5625  |
| 0000 0010 0000                             | -42.144     | 0.78125   |
| 0000 0001 0000                             | -48.165     | 0.39062   |
| 0000 0000 1000                             | -54.186     | 0.19531   |
| 0000 0000 0100                             | -60.205     | 0.097656  |
| 0000 0000 0010                             | -66.226     | 0.04828   |
| 0000 0000 0001                             | -72.247     | 0.02441   |

Given a desired attenuation, the shifting value  $\text{Gain}_{\text{SHIFT}}(2:0)$  can be determined by a table look-up. Refer to Table 6.

**TABLE 6. GAIN SHIFT VALUES**

| $\text{GAIN}_{\text{SHIFT}}$<br>(2:0) | GAIN (dBFS) | SCALE<br>BY | SCALING GAIN<br>( $V_{\text{OUT}}/V_{\text{IN}}$ )% |
|---------------------------------------|-------------|-------------|---|
| 000                                   | -72.247     | 4096        | 0.02441   |
| 001                                   | -48.165     | 256         | 0.39062   |
| 010                                   | -30.103     | 32          | 3.125   |
| 011                                   | -24.082     | 16          | 6.25  |
| 100                                   | -18.062     | 8           | 12.5  |
| 101                                   | -12.041     | 4           | 25.0  |
| 110                                   | -6.021      | 2           | 50.0  |
| 111                                   | 0           | 1           | 100.0   |

The gain control is loaded into Control Word 0xa.

0xa, bits 14:12 =  $\text{Gain}_{\text{SHIFT}}(2:0)$

0xa, bits 11:0 =  $\text{Gain}_{\text{MULT}}(11:0)$

## Sampling NCO

The Sample Rate NCO provides the SAMPLE CLK and sample clock phase information to the data input FIFO's, the shaping filters and the interpolation filters. The input sample rate is set by the sample clock. The sample clock is the MSB of the NCO accumulator and controls the movement of sample data from the user to the shaping filters. The coarse phase of the NCO accumulator controls the processing of the shaping filter at 4x, 8x, or 16x the sample clock rate. The fine phase of the NCO accumulator controls the processing of the interpolation filter as it re-samples the data from the shaping filter to the clock rate. The block diagram is shown in Figure 11.

The sample frequency, SF, is set with 48-bit resolution. The LSB is  $f_{\text{CLK}}/2^{48}$ . The internal accumulator resolution is 48 bits. Given a desired sample frequency,  $f_s$ , the value for SF(47:0) can be calculated by the following equation.

$$\text{SF}(47:0) = \text{INT} [(f_s / f_{\text{CLK}}) * 2^{48}]$$

The sample frequency, SF(47:0) is loaded 16 bits at a time into Control Words 4, 5, and 6.

0x4, bits 15:0 = SF (47:32)

0x5, bits 15:0 = SF (31:16)

0x6, bits 15:0 = SF (15:0)

The output of the phase accumulator can be offset by phase increments of 90 degrees without affecting the operation of the phase accumulator. The desired offset increment is loaded into FIR Control (0xd, bits 11:10).

Since it is not possible to represent all frequencies exactly with an NCO, the phase accumulator length has been extended to minimize the effect of phase error accumulation. At an update rate of 1MHz, half an LSB of error in loading the 48-bit accumulator is  $1.8e-9$ . The accumulated phase error after 1 year is 0.056 of a bit.

## Leap Counter

In addition to lengthening the NCO accumulator, a 32-bit counter is available for realizing fixed integer interpolation rates. The carry-out of the fixed integer counter can be used to clear the coarse and/or fine phase of the sample rate NCO. The fixed integer counter also provides a precarry-out that can be used to synchronize fixed integer counters in other devices. The fixed integer counter is enabled by FIR Control (0xd, bit 12).

In programming the FID to clear the NCO accumulator, consideration must be provided to ensure that FID is programmed to clear the Error term only when the desired error term should have been zero with an integer multiple of the symbol rate. Selecting GSM as an example, the FID should clear the NCO accumulator every third multiple of the symbol rate or every  $270833.333 * 3$  sample clocks, as the error term should only be zeroed during integer multiples of

the symbol rate. This would clear the NCO accumulator every 3 seconds or at a 1/3 Hz rate. The frequency of the FID carryout can range from Fclk to Fclk/2^32. The value of FID is determined from:

$$FID(31:0) = [(fclk / fco)]$$

Where fco is the desired frequency of the carryout, which in the previous example is 1/3 Hz and the fclk is an integer multiple of the sample frequency, say 65MHz. The resultant value for the FID would be (65MHz/1/3Hz) or 195e6. The programmed integer values for the FID are loaded 16 bits at a time into Control Words 2 and 3.

0x2, bits 15:0 = FID (31:16)

0x3, bits 15:0 = FID (15:0)

Loading 195e6 into the FID would result in 0x2, being 0x0b9f, and 0x3 being 0x76c0.

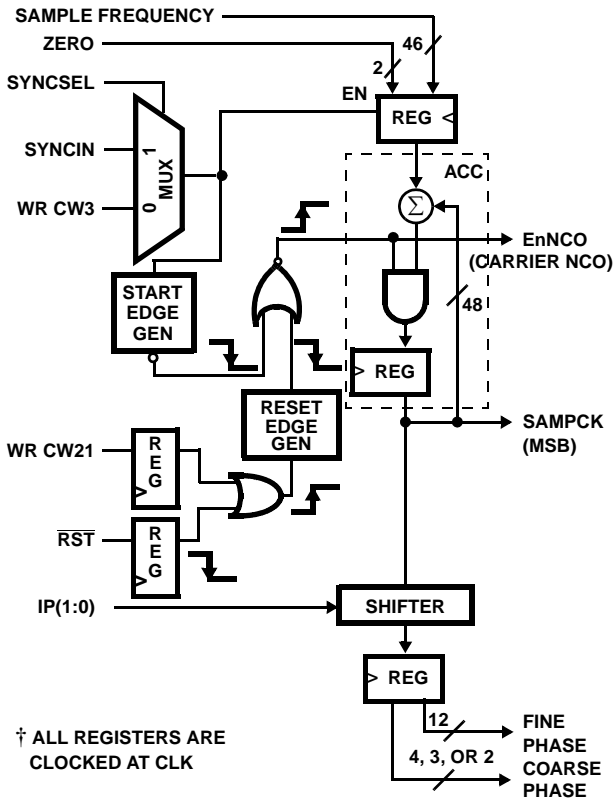

FIGURE 11. RE-SAMPLING NCO BLOCK DIAGRAM

### Fixed Coefficient 11-TAP Interpolating Half-band

Following the post-FIR gain profile block is a fixed coefficient 11-tap interpolate by 2 Half-Band filter. The default mode is to bypass the filter with the setting of control word 0x0d, bit 9 enabling the filter. If bypassed, the data to the filter is zeroed which reduces power consumption. The halfband filter coefficients are:

3, 0, -25, 0, 150, 256, 150, 0, -25, 0, 3

The output of this filter is rounded to 20-bits. The output is checked for saturation and limited if necessary. The data exits the halfband filter as a parallel I<20:0> and Q<20:0> data stream at the rate of fs\*IP\*2. Figure 12 shows the frequency response of the Half-Band filter.

### Interpolation Filter

The shaped sample data is input to the interpolating filter at the interpolation rate. The Interpolator filter resamples the shaped I and Q data to establish the final output sample rate of the channel. The output sample rate is always the clock rate. The Interpolator uses the fine phase values from the Symbol Rate NCO to compute the fine interpolated samples at the clock rate. The number of interpolated samples is set by the following ratio:  $n_{IS} = f_{CLK} / f_S / IP$ .

The nulls in the interpolation filter frequency response align with the interpolation images of the shaping filter. The impulse response of the Interpolation filter is shown in Figures 13A through 13C for varying interpolation ratios.

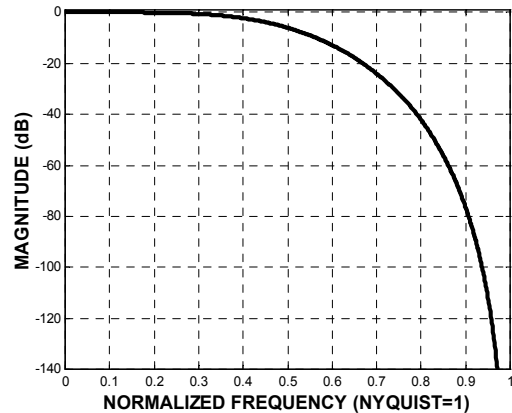

FIGURE 12. HALF BAND FILTER RESPONSE

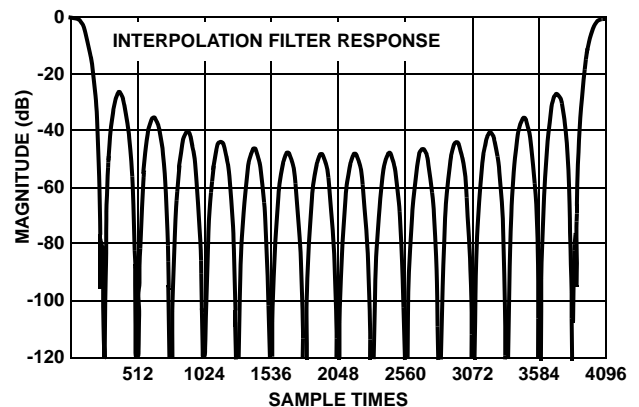

FIGURE 13A. INTERPOLATION FILTER IMPULSE RESPONSE  
L = 16; FOUT = 4096



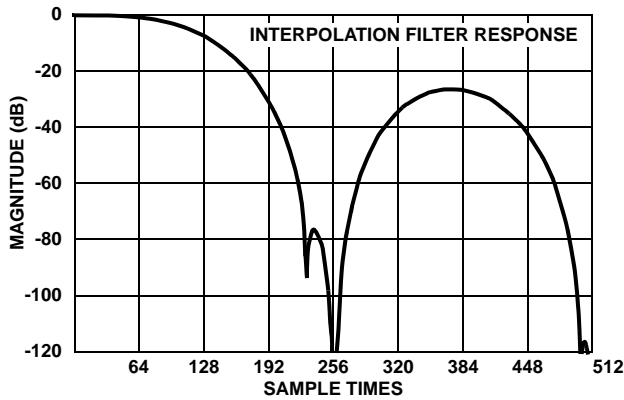

FIGURE 13B. INTERPOLATION FILTER IMPULSE RESPONSE  
L = 16; FOUT = 4096

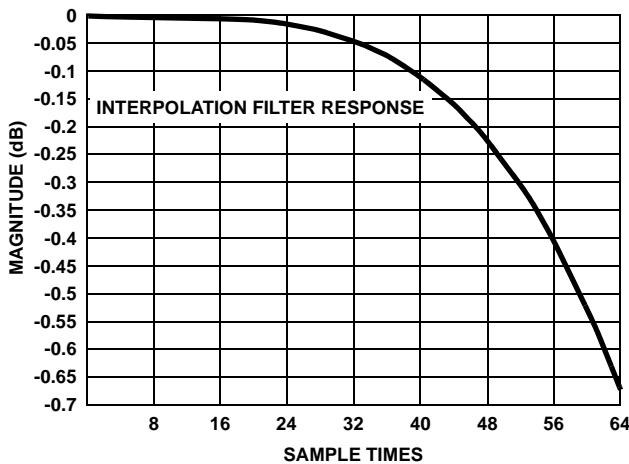

FIGURE 13C. INTERPOLATION FILTER IMPULSE RESPONSE  
L = 16; FOUT = 4096

### Carrier NCO

Following the interpolating filter section, the samples are modulated onto a carrier signal via a complex multiply operation. The Carrier NCO provides the quadrature local oscillator references to the complex mixer.

The NCO has provisions for programming the frequency and phase offset. The NCO has a 32 bit frequency control providing sub-hertz resolution at the maximum clock rate. The carrier NCO phase accumulator feedback can be preset to synchronize multiple channels. The carrier NCO has a 32-bit 2's complement programmable frequency increment value which can range from  $-2^{31}$  to  $2^{31}$  for a NCO output range of  $-f_{CLK}/2$  to  $f_{CLK}/2$ . For  $f_{CLK} = 104\text{MHz}$ , the frequency will range from  $-52\text{MHz}$  to  $+52\text{MHz}$ .

The maximum error is  $104\text{MHz}/(2^{32}) = 0.0242\text{Hz}$ . The carrier frequency can be calculated from the value loaded into Control Address 0x8 and 0x9 by:

$$F_{\text{CARRIER}} = \text{CR}(31:0) \times f_{\text{CLK}} \times 2^{-32} \quad (\text{EQ. 5})$$

where CR(31:0) is the 32-bit frequency control word which can range from  $-2^{31}$  to  $2^{31}$  for a NCO output range of  $-f_{CLK}/2$  to  $f_{CLK}/2$ .  $f_{CLK}$  is the CLK frequency.

This NCO frequency range allows for spectral inversion. Given a desired carrier frequency, the value for CR(31:0) loaded into the part can be calculated by:

$$\text{CR}(31:0) = \text{INT}[F_C / f_{\text{CLK}} * 2^{32}] \quad (\text{EQ. 6})$$

where INT[X] is the integer part of the real number X.

The vector rotation can also be controlled by the sign of the CF value. When CF is a positive value a counterclockwise vector rotation is produced. When CF is a negative value a clockwise vector rotation is produced.

The carrier frequency is loaded 16 bits at a time into Control Words 8 and 9.

0x8, bits 15:0 = CF (31:16)

0x9, bits 15:0 = CF (15:0)

The 16-bit carrier phase offset initializes the most-significant 16-bits of the phase accumulator. The least significant 16 bits of the phase accumulator are cleared. Given a desired carrier phase offset, the value CO(31:0) can be calculated by the following equation.

$$\text{CO}(31:0) = \text{INT}\left[\frac{(\text{PhaseOffset})^\circ}{360^\circ} * 2^{32}\right] \quad (\text{EQ. 7})$$

The carrier phase offset is loaded into Control Word 0x7.

Control Word 7 (15:0) = CO (31:16).

### Complex Mixer

The complex mixer multiplies the sin/cos terms generated by the carrier NCO sin/cos generator with the I and Q interpolated sample data. The mixers can be bypassed by programming the carrier frequency to zero. This action sets the sin/cos terms generated by the carrier NCO to 0 and 1 respectively. The block diagram of the Carrier NCO/Complex Mixer is shown in Figure 14.

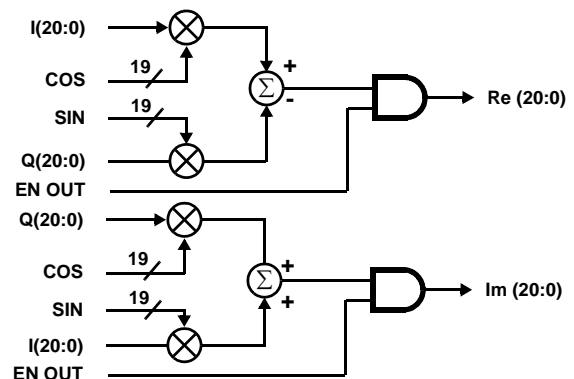

FIGURE 14. VECTOR MODULATOR/MIXER BLOCK DIAGRAM

The resulting complex output is given by the following equations.

$$\text{Re mixer (20:0)} = \text{I(20:0)} * \cos(18:0) - \text{Q(20:0)} * \sin(18:0)$$

$$\text{Im mixer (20:0)} = \text{Q(20:0)} * \cos(18:0) + \text{I(20:0)} * \sin(18:0)$$

(Vector weighting for block diagram)

$$\text{I (20:0)} = 2^1 \dots 2^{-19}$$

$$\text{Q (20:0)} = 2^1 \dots 2^{-19}$$

$$\sin (18:0) = 2^0 \dots 2^{-18}$$

$$\cos (18:0) = 2^0 \dots 2^{-18}$$

$$\text{Re mixer(20:0)} = 2^1 \dots 2^{-19}$$

$$\text{Im mixer(20:0)} = 2^1 \dots 2^{-19}$$

### Output Processing

Output processing sums the modulated output of each channel to provide multi-carrier outputs. There are four 4-channel summers, which combined with the outputs IOUT, QOUT, and bidirectional outputs IIN and QIN can be configured by the user to support eight output modes. The output mode is determined by Device Control 0x78 bits 9:8 and Main Control 0xc, bit 7.

### Output Modes

**Cascade Mode:** In this mode IIN<19:0> and QIN<19:0> are configured as inputs for the real and imaginary cascade inputs. This is the only mode where IIN and QIN are configured as inputs.

The cascade input allows for more than four multi-channel transmissions by summing the complex modulated signals from other device's with the four channel summer. A cascade chain of four devices allows up to sixteen carriers. Each device delays it's 4-channel summation to align with the cascade in from the previous device. Device Control 0x78 bits 2:1, Cascade delay <1:0>, identifies the position in the

cascade chain to select the appropriate delay. Device Control 0x78, bit 3, Cascade input enable, zeroes the cascade-in data when the port is not in use. The output of the summation is saturated to prevent roll-over.

**Real:** Real data is output on IIN, QIN, IOUT, and QOUT.

**Imag:** Imaginary data is output on IIN, QIN, IOUT, and QOUT.

**Muxed I/Q:** The output data alternates between real and imaginary on clock time boundaries. The output signal ISTRB is asserted when the output data is real. The ISTRB is enabled by Device Control 0x78, bit 5. In this mode, the I/Q samples are decimated by two. This is the only mode in which the output data is decimated.

**NOTE:** When in Muxed I/Q mode the output order is I then Q.

**Muxed I/Q at 2x rate:** The output data alternates between real and imaginary within a clock time boundary. The output data is real when the clock is high, and imaginary when the clock is low. All I/Q samples are output, and there is no decimation of the output stream. Care should be utilized to ensure sufficient set-up time is achieved for the downstream device in the application, as data is alternating I then Q between clock boundaries.

**Complex out 1:** In this mode, complex data is output on IIN and QIN, while real data is output on IOUT and QOUT.

**Complex out 2:** In this mode, real data is output on IIN and QIN, while complex data is output on IOUT and QOUT.

**Complex out 3:** In this mode, complex data is output on IIN and QIN and complex data is output on IOUT and QOUT.

TABLE 7. OUTPUT MODES

| OUTPUT MODE           | MAIN CONTROL 0X0C, BIT 7 COMPLEX OUTPUT MODE | MAIN CONTROL 0X78, BITS 9:8 OUTPUT MODE | MAIN CONTROL 0X78, BIT 10 OUTPUT 2X SELECT | ISTRB | CLK | IIN<19:0> | QIN<19:0> | IOUT<19:0> | QOUT<19:0> |
|-----------------------|--|---|--|-------|-----|-----------|-----------|------------|------------|
| Cascade Mode          | 0  | 00                                      | 0  | X     | X   | Input re  | Input im  | re CASout  | im CASout  |
| Real                  | 0  | 01                                      | 0  | X     | X   | re SUM1   | re SUM2   | re SUM3    | re SUM4    |
| Imaginary             | 0  | 10                                      | 0  | X     | X   | im SUM1   | im SUM2   | im SUM3    | im SUM4    |
| Muxed I/Q             | 0  | 11                                      | 0  | 1     | X   | re SUM1   | re SUM2   | re SUM3    | re SUM4    |
|                       | 0  | 11                                      | 0  | 0     | X   | im SUM1   | im SUM2   | im SUM3    | im SUM4    |
| Muxed I/Q at 2X Rate  | 0  | 01                                      | 1  | X     | 1   | re SUM1   | re SUM2   | re SUM3    | re SUM4    |
|                       | 0  | 01                                      | 1  | X     | 0   | im SUM1   | im SUM2   | im SUM3    | im SUM4    |
| Complex Output Mode 1 | 1 (Ch. 0 only)                               | 01                                      | 0  | X     | X   | re SUM1   | im SUM1   | re SUM3    | re SUM4    |
| Complex Output Mode 2 | 1 (Ch. 2 only)                               | 01                                      | 0  | X     | X   | re SUM1   | re SUM2   | re SUM3    | im SUM3    |
| Complex Output Mode 3 | 1 (Ch. 0 and 2)                              | 01                                      | 0  | X     | X   | re SUM1   | im SUM1   | re SUM3    | im SUM3    |

NOTE: re CASout is re SUM1 + re CASinput, im CASout is im SUM1 + im CAS in.



TABLE 8. INPUT/OUTPUT MODES

| MAIN CONTROL 0X78, BITS 9:8 OUTPUT MODE | OUTEN <1:0> | IIN <19:0> | QIN <19:0> | IOUT <19:0> | QOUT <19:0> |
|---|-------------|------------|------------|-------------|-------------|
| 00                                      | 00          | Input      | Input      | Output      | Output      |
| 00                                      | 01          | Input      | Input      | Output      | HI-Z        |
| 00                                      | 10          | Input      | Input      | HI-Z        | Output      |
| 00                                      | 11          | Input      | Input      | HI-Z        | HI-Z        |
| 01,10,11                                | 00          | Output     | Output     | Output      | Output      |
| 01,10,11                                | 01          | Output     | Input      | Output      | HI-Z        |
| 01,10,11                                | 10          | Input      | Output     | HI-Z        | Output      |
| 01,10,11                                | 11          | Input      | Input      | HI-Z        | HI-Z        |

### 4-Channel Summers

#### Cascade Input

When in the complex cascade mode the 4-channel summer re 1 and im 1 are summed with the real and imaginary cascade inputs. The cascade input allows for more than four multi-channel transmissions by summing the complex modulated signals from other device's. A cascade chain of four devices allows up to sixteen carriers. Figure 15 illustrates cascading multiple devices. Each device delays its 4-channel summation to align with the cascade in from the previous device. Device Control 0x78, bits 2:1 identifies the position in the cascade chain. Device Control 0x78, bit 3 zeroes the cascade-in data when the port is not in use. The output of the summation is saturated to prevent roll-over.

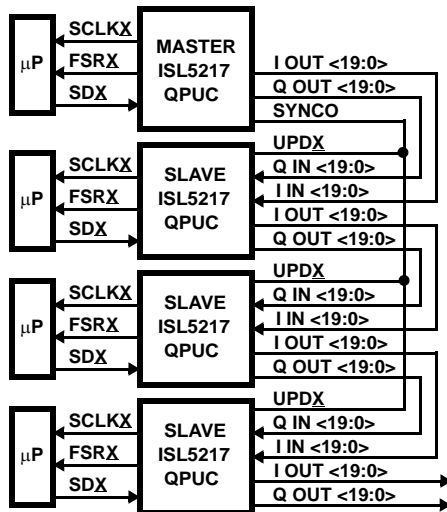
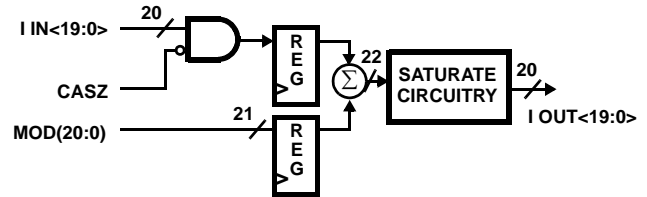

FIGURE 15. CASCADED QPUCs



† ALL REGISTERS ARE CLOCKED AT CLK

FIGURE 16. CASCADE INPUT BLOCK DIAGRAM

#### Output Formatter

The output can be formatted in either twos complement or offset binary. The OFFBIN pin is used to select the output format. The output ranges from 0x8001 to 0x7FFF for two's complement and from 0x0001 - 0xFFFF for offset binary.

#### Microprocessor Interface

NOTE: See Appendix A, Errata Sheet

The microprocessor interface allows the QPUC to appear as a memory mapped peripheral to the μP. Configuration data, I/Q sample data and RAM data can be accessed through this interface. The interface consists of a 16 bit bidirectional data bus, P<15:0>, seven bit address bus, A<6:0>, a write strobe ( $\overline{WR}$ ), a read strobe ( $\overline{RD}$ ) and a chip enable ( $\overline{CE}$ ). Two μP interface modes are supported through the input pin RDMODE. When low the device is configured for separate read and write strobe inputs. When high the device is configured for a common Read/Write and data strobe inputs. This mode redefines  $\overline{RD}$  into Read/Write Strobe and  $\overline{WR}$  into Data Strobe.

The address space is partitioned into five directly accessible regions, one for top control and one for each of the four channels. The Device Control space allows for configuration parameters that effect the entire device, cascade, output modes, and routing. The channel space allows for configuration parameters and sample data.

The master registers for the configuration data and I/Q sample data are located in these areas. There is a master

register and slave register pair for each configuration parameter and I/Q sample. The slave register for the I/Q samples is the first location of the FIFO. The master registers are clocked by the  $\mu\text{P}$  write strobe, are writable and cleared by a hard reset. The slave registers are clocked by device clock, are readable and cleared by either a hard or soft reset. The transfer of configuration data from the master register to the slave register can occur synchronously after an event or immediately after a four clock synchronization period.

Indirect addressing is used to access the gain profile RAM, the I coefficients RAM and the Q coefficients RAM. This type of access relies on loading the RAM data into direct address 0x14 and the RAM address into direct address 0x15. After a four clock synchronization period of the decoded address 0x15, the contents of the RAM data register is moved to the address pointed to by the RAM address register. The  $\mu\text{P}$  can perform back-to-back accesses to the RAM data register and RAM address register, but must maintain four  $f_{\text{CLK}}$  periods between accesses to the same address. This limits the maximum  $\mu\text{P}$  access rate for the RAM to  $104\text{MHz}/4 = 26\text{MHz}$ . The RAM address register defines a 16-bit address space that is partitioned into pages of 256 words by indirect address <9:8>. Indirect address <15> determines the access type, 1 = read; 0 = write.

The address map and bit field details for the microprocessor interface is shown in the Tables 10-47. The procedures for reading and writing to this interface are provided below.

### Microprocessor Read/Write Procedure

The QPUC offers the microprocessor read/write access to all of the configuration working registers, the gain profile RAM, the I coefficients RAM and the Q coefficients RAM. RDMODE determines the read/write mode for the microprocessor interface as detailed in the pin description table. The following examples have RDMODE set low, which configures the interface for separate  $\overline{\text{RD}}$  and  $\overline{\text{WR}}$  strobes.

### Configuration Read/Write Procedure

#### Write Access to the Configuration Master Registers

Perform a direct write to the configuration master registers by setting up the address A<6:0>, data P<15:0>, and generating  $\overline{\text{WR}}$  strobe. The overall configuration loading sequence is as shown. The order of writing to the device should be maintained as:

1. Write the Main Control register 0x0c. 0x9000 sets the immediate update and microprocessor hold bits.
2. Write Device Control 0x78, bit 0 to set the broadcast bit if writing to multiple channels. Set to 0 when writing to a single channel.
3. Write all remaining registers sequentially.
4. Load all filter and gain coefficients.

5. Repeat steps 2-4 for all channels.
6. Write control word 0x0c to the final configuration values.

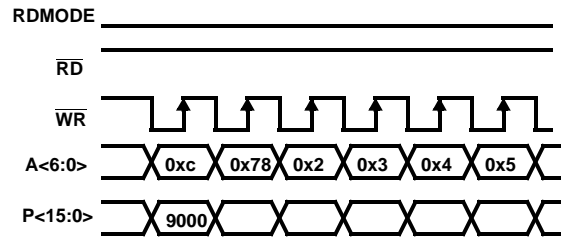

FIGURE 17. CONFIGURATION WRITE TRANSFER

#### Read Access to the Configuration Slave Registers

1. Perform a direct read of a configuration register by dropping the  $\overline{\text{RD}}$  line low to transfer data from the register selected by A<6:0> onto the data bus P<15:0>.

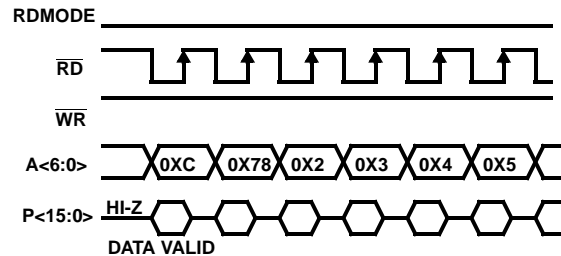

FIGURE 18. CONFIGURATION READ TRANSFER

### I/Q Sample Read/Write Procedure

#### Write Access to the I/Q Sample Master Registers

2. Enable the parallel input format by clearing bit 15 of the Serial control register, 0x11.
3. Perform a direct write to Control word 1 by setting up the address A<6:0>, data P<15:0>, and generating a rising edge on  $\overline{\text{WR}}$ .
4. Perform a direct write to Control word 0 by setting up the address A<6:0>, data P<15:0>, and generating a rising edge on  $\overline{\text{WR}}$ . A write strobe transfers the contents of the I/Q master registers to the first location of the FIFO.
5. Wait 4 clock cycles before performing the next write to the Q data master register.

#### Read Access to the I/Q Sample Slave Registers

1. Perform a direct read of the I slave register by dropping the  $\overline{\text{RD}}$  line low to transfer data from the slave register selected by A<6:0> onto the data bus P<15:0>.

## Gain Profile RAM Read/Write Procedure

### Write Access to the Gain Profile RAM

1. Enable the gain profile hold mode by setting bit 14 of the Main Control register 0x0c.
2. Load the RAM data to location 0x14.
3. Load the RAM write address to location 0x15. A write strobe transfers the contents of the register at location 0x14 into the RAM location specified by the contents of the register at location 0x15. (Indirect address[15] =0).
4. Wait 4 clock cycles before performing the next write to the RAM data register.
5. Repeat steps 2-4.
6. Return gain control back to the channel by disabling the gain profile hold 0x0c, bit 14.

### Read Access to the Gain Profile

1. Enable the gain profile hold mode by setting bit 14 of the Main Control register 0x0c.
2. Load the RAM read address and 0x8000 to location 0x15. A read strobe transfers the contents of the RAM location specified by the contents of the register at location 0x15 onto the read bus. (Indirect address[15] =1, Indirect address[9:8] = '00').
3. Wait 4 clock cycles before performing the next write to the RAM address register.
4. Repeat steps 2-3.
5. Return gain control back to the channel by disabling the gain profile hold 0x0c, bit 14.

## Coefficients RAM Read/Write Procedure (16-bit 2's Complement Format)

The RAM address used for the I and Q coefficient RAM depends on the filter. Indirect page 3 is used when the coefficients are equal. When the coefficients are not equal indirect page 1 is used.

### Write Access to the Coefficient RAMs When I Not Equal Q

1. Enable the  $\mu$ P hold mode by setting bit 12 of the Main Control register 0x0c.
2. Load the RAM data to location 0x14 with the Q coefficient.
3. Load the RAM data to location 0x14 with the I coefficient.
4. Load the RAM write address to location 0x15. A write strobe transfers the contents of the register at location 0x14 into the RAM location specified by the contents of the register at location 0x15. (Indirect address[15] =0, Indirect address[9:8] = '01').
5. Wait 4 clock cycles before performing the next write to the RAM data register.
6. Repeat steps 2-5.
7. Return RAM control back to the channel by disabling the  $\mu$ P hold mode.

### Write Access to the Coefficient RAMs When I Equal Q

1. Enable the  $\mu$ P hold mode by setting bit 12 of the Main Control register 0x0c.
2. Load the RAM data to location 0x14 with the coefficient.
3. Load the RAM write address to location 0x15. A write strobe transfers the contents of the register at location 0x14 into the RAM location specified by the contents of the register at location 0x15. (Indirect address[15] =0, Indirect address[9:8] = '11').
4. Wait 4 clock cycles before performing the next write to the RAM data register.
5. Repeat steps 2-4.
6. Return RAM control back to the channel by disabling the  $\mu$ P hold mode.

### Read Access to the I Coefficient RAM

1. Enable the  $\mu$ P hold mode by setting bit 12 of the Main Control register 0x0c.
2. Load the RAM read address and 0x8100 to location 0x15. A read strobe transfers the contents of the RAM location specified by the contents of the register at location 0x15 onto the read bus. (Indirect address[15] =1, Indirect address[9:8] = '01').
3. Wait 4 clock cycles before performing the next write to the Ram address register.
4. Repeat steps 2-3.
5. Return RAM control back to the channel by disabling the  $\mu$ P hold mode.

### Read Access to the Q Coefficient RAM

1. Enable the  $\mu$ P hold mode by setting bit 12 of the Main Control register 0x0c.
2. Load the RAM read address and 0x8200 to location 0x15. A read strobe transfers the contents of the RAM location specified by the contents of the register at location 0x15 onto the read bus. (Indirect address[15] =1, Indirect address[9:8] = '10').
3. Wait 4 clock cycles before performing the next write to the RAM address register.
4. After all data has been loaded, return RAM control back to the channel by disabling the  $\mu$ P hold mode.

## Coefficients RAM Read/Write Procedure (24-bit Floating Point Format)

The 24-bit floating point mode must be enabled by setting bit 12 of control word 0x17. The I and Q coefficients must be loaded separately in this mode.

### Write access to the Coefficient RAMs

1. Enable the  $\mu$ P hold mode by setting bit 12 of the Main Control register 0x0c and bit 12 of the Test Control register 0x17.
2. Load the RAM data to location 0x14 with the iCoef<3:0>, iShift<3:0>, qCoef<3:0>, qShift<3:0>.

3. Load the RAM data to location 0x14 with the qCoef<19:4>.
4. Load the RAM data to location 0x14 with the iCoef<19:4>.
5. Load the RAM write address to location 0x15. A write strobe transfers the contents of the three previously loaded registers at location 0x14 into the RAM location specified by the contents of the register at location 0x15. (Indirect address[15] = 0, Indirect address[9:8] = '01').
6. Wait 4 clock cycles before performing the next write to the RAM data register.
7. Repeat steps 2-6.
8. Return RAM control back to the channel by disabling the  $\mu$ P hold mode.

### Read Access to the Coefficient RAM

1. Enable the  $\mu$ P hold mode by setting bit 12 of the Main Control register 0x0c and bit 12 of the Test Control register 0x17.
2. Load the RAM read address and 0x8X00 to location 0x15. Three read strobes are required to transfer the contents of the RAM location specified by the contents of the register at location 0x15 onto the read bus. Indirect address[15] = 1, Indirect address[9:8] = '01', reads back the iCoef value, Indirect address[15] = 1, Indirect address[9:8] = '10', reads back the qCoef value, Indirect address[15] = 1, Indirect address[9:8] = '11', reads back the iShift<3:0>, iShift<3:0>, qCoef<3:0>, qShift<3:0> value.
3. Wait 4 clock cycles between all of the above writes before performing the next write to the Ram address register.
4. Repeat steps 2-3.
5. Return RAM control back to the channel by disabling the  $\mu$ P hold mode.

### Channel Status

The present status of the channel is latched by the single channel  $\mu$ P interface into the Status 0x16 register bits 11:0. These bits represent the channel flushed, FIR and FIFO overflow/underflow, FIFO read address, and FIFO almost and empty flags. 0x16 bits 10:7 and bit 3 are or'ed and latched into the Device Top Control 0x7e. The bits in 0x7e represent the fault status of each channel and the saturation status of each summer. The detection of a FIFO overflow puts the channel in the off-line mode, unless disabled by assertion of 0x0c, bit 1. The off-line function takes the channel off-line by forcing the FIFO read address to '000', which forces 0 data out of the FIFO. The channel flushed status bit in control word 0x16, may be monitored to find out when the zeroes have propagated through the entire channel pipeline chain. The channel flushed status is asserted 24 sample clocks after entering the off-line mode. Once a channel fault is latched into the Top control 0x7e, 15:12 a write to this location is required to clear the faulted status.

### Reset

There are two types of resets, a hard reset and a soft reset. A hard reset can occur by asserting the input pin  $\overline{\text{RESET}}$ , or

by the  $\mu$ P issuing a reset command to the top control register 0x7F, bit 1. A hard reset affects the entire device, leaving the QPUC in an idle state awaiting configuration. This type of reset returns the master and slave registers to their default values, clears the FIFO pointer, the NCO accumulators, the RAM pointers, and zeroes the data RAM. The data RAM locations are written with a zero value immediately after the reset is deasserted.

A soft reset occurs by the  $\mu$ P issuing a reset command to the channel's immediate action control register 0xF, bit 1. A soft reset is similar to the hard reset but does not clear the master registers and its action is limited only to that channel. A soft reset leaves the channel in an idle state, awaiting an update to begin processing.

### Update Control

There are several mechanisms for updating slave registers from the master registers. If hardware UPD $\underline{X}$  and TXEN $\underline{X}$  will be used the following control bits should be programmed:

1. Main control register 0x0c bit 5 must be set to 1 to enable hardware TXEN $\underline{X}$  and UPD $\underline{X}$ .
2. Serial control register 0x11 bits 7:6 should be programmed to configure which TXEN $\underline{X}$  a channel will respond to.
3. Serial control register 0x11 bits 5:4 should be programmed to configure which UPD $\underline{X}$  a channel will respond to.
4. Update Mask control register 0x0e bits 10:1 should be set to configure which slave registers will be updated from their corresponding master registers upon a non-immediate channel update. Those registers with their update mask bit set to 1 are enabled registers.

The 6 update mechanisms that are described below cause the slave registers to be updated from the contents of the corresponding master register.

1. Immediate Update - Set bit 15 of cword 0x0c to a 1 to implement this mode. In immediate update mode, the slave register is updated 4 CLKS after the master register is written (update mask register is ignored).
2. Hardware Update - If the channel hardware update is enabled, upon assertion of UPD $\underline{X}$ , the enabled slave registers are updated.
3. Software Update - Upon assertion of a channel software update (bit 0 of control register 0x0f), the enabled slave registers are updated.
4. External Hardware TXEN $\underline{X}$  Assertion - If the channel hardware txEnable is enabled, upon assertion of TXEN $\underline{X}$ , the enabled slave registers are updated.
5. Internal Hardware TXEN $\underline{X}$  Assertion - If the internal hardware txEnable function is enabled (bit 5 of cword 0x0c), upon assertion of the internal TXEN $\underline{X}$  (kicked off by either type of dynamic channel update as described in items 3 and 4 above), the enabled slave registers are updated.

6. Software TXEN $\bar{X}$  Assertion - Upon assertion of a channel software TXEN $\bar{X}$  (bit 0 of cword 0x0c), the enabled slave registers are updated.

### Starting Sequence

Channel processing begins when the slave register of the sample frequency and the interpolation phase are updated with a non-zero value. The sample rate NCO provides the timing strobes that drive the channel processing logic.

The starting sequence can be applied to one channel, multiple channels, and multiple devices.

When starting multiple channels through a software update, a broadcast write, to an immediate action register in the channel address space asserts an update strobe.

When starting multiple QPUCs through a software update, a write to the top control immediate action register, 0x78, bit 15 asserts the SYNCO pin. The first chip acts as a master and is tied to an UPD $\bar{X}$  pin of the remaining chips.

A delayed starting sequence of a channel can be realized by taking advantage of the On line mode defined in Main control (0xc, bit 6). The On line mode allows  $\mu$ P access to the RAM's and allows the NCO's to operate normally but inhibits processing by forcing the FIFO data to zero.

### JTAG and Built in Self Test

**JTAG:** The IEEE 1149.1 Joint Test Action Group boundary scan standard operational codes shown in Table 9 are supported. A separate application note is available with implementation details and the BSDL file is available.

TABLE 9. JTAG OP CODES SUPPORTED

| INSTRUCTION    | OP CODE |
|----------------|---------|
| EXTEST         | 0000    |
| IDCODE         | 0001    |
| SAMPLE/PRELOAD | 0010    |
| INTEST         | 0011    |
| BYPASS         | 1111    |

**Self test** is initiated by resetting the part and then loading a given configuration register set, filter coefficient set, and gain profile ramp. Control word 0x78, bit 14 should be set to 1 to enter the self test mode. Upon assertion of a channel 0 update anded with updateMask bit 15, the device will begin computing a signature which may then be read back from control word 0x7d, bits <14:3>. Control word 0x7d, bit 15 reflects the validity (completion) of the test. This bit will be cleared upon assertion of the 0x78, bit 14 test mode bit or upon assertion of the channel 0 update and will be set to 1 upon completion of the test.

### Power-up Sequencing

The ISL5217 core and I/O blocks are isolated by structures which may become forward biased if the supply voltages are

not at specified levels. During the power-up and power-down operations, differences in the starting point and ramp rates of the two supplies may cause current to flow in the isolation structures which, when prolonged and excessive, can reduce the usable life of the device. In general, the most preferred case would be to power-up or down the core and I/O structures simultaneously. However, it is also safe to power-up the core prior to the I/O block if simultaneous application of the supplies is not possible. In this case, the I/O voltage should be applied within 10 ms to 100 ms nominally to preserve component reliability. Bringing the core and I/O supplies to their respective regulation levels in a maximum time frame of a 100 ms, moderates the stresses placed on both the power supply and the ISL5217. When powering down, simultaneous removal is preferred, but It is also safe to remove the I/O supply prior to the core supply. If the core power is removed first, the I/O supply should also be removed within 10-100mS.



**Absolute Maximum Ratings**

Supply Voltage . . . . . +3.8V  
 Input, Output or I/O Voltage . . . . . GND -0.5V to  $V_{CC}$  +0.5V  
 ESD Classification . . . . . Class I

**Operating Conditions**

Voltage Range Core,  $V_{CCC}$  . . . . . +2.4V to +2.6V  
 Voltage Range I/O,  $V_{CCIO}$  (Note 2) . . . . . +3.15V to +3.45V  
 Temperature Range  
   Industrial . . . . . -40°C to 85°C  
 Input Low Voltage . . . . . 0V to +0.8V  
 Input High Voltage . . . . . .2V to  $V_{CC}$

**Thermal Information**

Thermal Resistance (Typical, Notes 1, 3)  $\theta_{JA}$  (°C/W)  
 196 Lead BGA Package . . . . . 33  
 w/200 LFM Air Flow . . . . . 29  
 w/400 LFM Air Flow . . . . . 27  
 Maximum Package Power Dissipation at 85°C  
 196 Lead BGA Package . . . . . 1.97W  
 Maximum Storage Temperature Range . . . . . -65°C to 150°C  
 Maximum Junction Temperature . . . . . 150°C  
 Maximum Lead Temperature (Soldering 10s) . . . . . 300°C

**CAUTION:** Stresses above those listed in "Absolute Maximum Ratings" may cause permanent damage to the device. This is a stress only rating and operation of the device at these or any other conditions above those indicated in the operational sections of this specification is not implied.

**NOTES:**

- $\theta_{JA}$  is measured in free air with the component mounted on a high effective thermal conductivity test board with "direct attach" features. See Tech Brief TB379.
- Single supply operation of both the core  $V_{CCC}$  and I/O  $V_{CCIO}$  at 2.5V is allowed. Degradation of the I/O timing should be expected.
- Tie 196CABGA package rows F, G, H, and J pins 6-9 to heat sink or ground to ensure maximum device heat dissipation.

**DC Electrical Specifications**  $V_{CCC} = 2.5 \pm 5\%$ ,  $V_{CCIO} = 3.3 \pm 5\%$ ,  $T_A = -40^\circ\text{C}$  to  $85^\circ\text{C}$ 

| PARAMETER                          | SYMBOL     | TEST CONDITIONS   | MIN  | MAX | UNITS         |
|------------------------------------|------------|---|------|-----|---------------|
| Logical One Input Voltage          | $V_{IH}$   | $V_{CCC} = 2.6\text{V}$ , $V_{CCIO} = 3.45\text{V}$   | 2.0  | -   | V             |
| Logical Zero Input Voltage         | $V_{IL}$   | $V_{CCC} = 2.4\text{V}$ , $V_{CCIO} = 3.15\text{V}$   | -    | 0.8 | V             |
| Clock Input High                   | $V_{IHC}$  | $V_{CCC} = 2.6\text{V}$ , $V_{CCIO} = 3.45\text{V}$   | 2.0  | -   | V             |
| Clock Input Low                    | $V_{IHL}$  | $V_{CCC} = 2.4\text{V}$ , $V_{CCIO} = 3.15\text{V}$   | -    | 0.8 | V             |
| Output High Voltage                | $V_{OH}$   | $I_{OH} = -2\text{mA}$ , $V_{CCC} = 2.4\text{V}$ , $V_{CCIO} = 3.15\text{V}$  | 2.6  | -   | V             |
| Output Low Voltage                 | $V_{OL}$   | $I_{OL} = 2\text{mA}$ , $V_{CCC} = 2.4\text{V}$ , $V_{CCIO} = 3.15\text{V}$   | -    | 0.4 | V             |
| Input Leakage Current              | $I_L$      | $V_{IN} = V_{CCIO}$ or GND, $V_{CCC} = 2.6\text{V}$ , $V_{CCIO} = 3.45\text{V}$                                       | -10  | 10  | $\mu\text{A}$ |
| Output Leakage Current             | $I_H$      | $V_{IN} = V_{CCIO}$ or GND, $V_{CCC} = 2.6\text{V}$ , $V_{CCIO} = 3.45\text{V}$                                       | -10  | 10  | $\mu\text{A}$ |
| Input Pull-up Leakage Current Low  | $I_{SL}$   | $V_{IN} = V_{CCIO}$ or GND, $V_{CCC} = 2.6\text{V}$ , $V_{CCIO} = 3.45\text{V}$ , TMS, $\overline{\text{TRST}}$ , TDI | -500 | -   | $\mu\text{A}$ |
| Input Pull-up Leakage Current High | $I_{SH}$   | $V_{IN} = V_{CCIO}$ or GND, $V_{CCC} = 2.6\text{V}$ , $V_{CCIO} = 3.45\text{V}$ , TMS, $\overline{\text{TRST}}$ , TDI | -    | 10  | $\mu\text{A}$ |
| Standby Power Supply Current       | $I_{CCSB}$ | $V_{CCC} = 2.6\text{V}$ , $V_{CCIO} = 3.45\text{V}$ , Outputs Not Loaded  | -    | 5   | mA            |
| Operating Power Supply Current     | $I_{CCOP}$ | $f = 80\text{MHz}$ , $V_{IN} = V_{CCIO}$ or GND, $V_{CCIO} = 3.45\text{V}$ , $V_{CCC} = 2.6\text{V}$                  | -    | 540 | mA (Note 4)   |
| Input Capacitance                  | $C_{IN}$   | Freq = 1MHz, $V_{CCIO}$ Open, All Measurements Are Referenced to Device Ground  | -    | 7   | pF (Note 5)   |
| Output Capacitance                 | $C_{OUT}$  | Freq = 1MHz, $V_{CCIO}$ Open, All Measurements are Referenced to Device Ground  | -    | 7   | pF (Note 5)   |

**NOTES:**

- Power Supply current is proportional to operation frequency. Typical rating for  $I_{CCOP}$  is 7mA/MHz.
- Capacitance  $T_A = 25^\circ\text{C}$ , controlled via design or process parameters and not directly tested. Characterized upon initial design and at major process or design changes.

**AC Electrical Specifications**  $V_{CC} = 2.5 \pm 5\%$ ,  $V_{CCIO} = 3.3 \pm 5\%$ ,  $T_A = -40^\circ\text{C}$  to  $85^\circ\text{C}$  (Note 6)

| PARAMETER   | SYMBOL             | MIN | MAX | UNITS      |
|---|--------------------|-----|-----|------------|
| CLK Frequency   | $f_{\text{CLK}}$   | -   | 104 | MHz        |
| CLK Clock Period  | $t_{\text{CLK}}$   | 9.6 | -   | ns         |
| CLK High  | $t_{\text{CH}}$    | 3   | -   | ns         |
| CLK Low   | $t_{\text{CL}}$    | 3   | -   | ns         |
| Setup Time IIN<19:0> or QIN<19:0> to CLK  | $t_{\text{IQISC}}$ | 5   | -   | ns         |
| Hold Time IIN<19:0> or QIN<19:0> from CLK   | $t_{\text{IQIHC}}$ | 0   | -   | ns         |
| Setup Time TXEN $\bar{X}$ to CLK  | $t_{\text{TSC}}$   | 4   | -   | ns         |
| Hold Time TXEN $\bar{X}$ from CLK   | $t_{\text{THC}}$   | 0   | -   | ns         |
| Setup Time UPD $\bar{X}$ to CLK   | $t_{\text{USC}}$   | 4   | -   | ns         |
| Hold Time UPD $\bar{X}$ from CLK  | $t_{\text{UHC}}$   | 0   | -   | ns         |
| Setup Time $\overline{\text{RESET}}$ High to CLK  | $t_{\text{RSC}}$   | 4   | -   | ns         |
| Hold Time $\overline{\text{RESET}}$ High from CLK (Note 7)                                | $t_{\text{RHC}}$   | 1   | -   | ns         |
| $\overline{\text{RESET}}$ Low Pulse Width (Note 7)  | $t_{\text{RPW}}$   | 10  | -   | CLK Cycles |
| $\overline{\text{WR}}$ Pulse Width High   | $t_{\text{WPWH}}$  | 5   | -   | ns         |
| $\overline{\text{WR}}$ Pulse Width Low  | $t_{\text{WPWL}}$  | 5   | -   | ns         |
| $\overline{\text{WR}}$ Pulse Width Low (RDMODE=1)   | $t_{\text{WPL1}}$  | 6   | -   | ns         |
| Setup Time A<6:0> to $\overline{\text{WR}}$   | $t_{\text{ASW}}$   | 10  | -   | ns         |
| Hold Time A<6:0> from $\overline{\text{WR}}$  | $t_{\text{AHW}}$   | 0   | -   | ns         |
| Setup Time $\overline{\text{CS}}$ to $\overline{\text{WR}}$                               | $t_{\text{CSW}}$   | 4   | -   | ns         |
| Hold Time $\overline{\text{CS}}$ from $\overline{\text{WR}}$                              | $t_{\text{CHW}}$   | 0   | -   | ns         |
| Setup Time P<15:0> to $\overline{\text{WR}}$  | $t_{\text{PSW}}$   | 8   | -   | ns         |
| Hold Time P<15:0> from $\overline{\text{WR}}$   | $t_{\text{PHW}}$   | 0   | -   | ns         |
| Enable P<15:0> from $\overline{\text{RD}}$ (Note 5)                                       | $t_{\text{PER}}$   | -   | 6   | ns         |
| Disable P<15:0> from $\overline{\text{RD}}$ (Note 5)                                      | $t_{\text{PDR}}$   | -   | 6   | ns         |
| Setup Time $\overline{\text{RD}}$ to $\overline{\text{WR}}$ (RDMODE=1) (Note 7)           | $t_{\text{RSW1}}$  | 0   | -   | ns         |
| Hold Time $\overline{\text{RD}}$ from $\overline{\text{WR}}$ (RDMODE=1) (Note 7)          | $t_{\text{RHW1}}$  | 0   | -   | ns         |
| Setup Time A<6:0> to $\overline{\text{WR}}$ (RDMODE=1)                                    | $t_{\text{ASW1}}$  | 10  | -   | ns         |
| Hold Time A<6:0> from $\overline{\text{WR}}$ (RDMODE=1)                                   | $t_{\text{AHW1}}$  | 0   | -   | ns         |
| Setup Time $\overline{\text{CS}}$ to $\overline{\text{WR}}$ (RDMODE=1)                    | $t_{\text{CSW1}}$  | 4   | -   | ns         |
| Hold Time $\overline{\text{CS}}$ from $\overline{\text{WR}}$ (RDMODE=1)                   | $t_{\text{CHW1}}$  | 0   | -   | ns         |
| Setup Time P<15:0> to $\overline{\text{WR}}$ (RDMODE=1)                                   | $t_{\text{PSW1}}$  | 8   | -   | ns         |
| Hold Time P<15:0> from $\overline{\text{WR}}$ (RDMODE=1)                                  | $t_{\text{PHW1}}$  | 0   | -   | ns         |
| Enable P<15:0> from $\overline{\text{WR}}$ or $\overline{\text{RD}}$ (RDMODE=1) (Note 7)  | $t_{\text{PEWR1}}$ | -   | 6   | ns         |
| Disable P<15:0> from $\overline{\text{WR}}$ or $\overline{\text{RD}}$ (RDMODE=1) (Note 7) | $t_{\text{PDWR1}}$ | -   | 6   | ns         |
| Setup Time SD $\bar{X}$ to SCLK $\bar{X}$   | $t_{\text{SSS}}$   | 8   | -   | ns         |
| Hold Time SD $\bar{X}$ from SCLK $\bar{X}$  | $t_{\text{SHS}}$   | 0   | -   | ns         |
| IOUT<19:0> or QOUT<19:0> Enable Time from OUTEN<1:0> (Note 7)                             | $t_{\text{IQOE}}$  | -   | 7   | ns         |
| IIN<19:0> or QIN<19:0> Enable Time from CLK (Note 7)                                      | $t_{\text{IQIE}}$  | -   | 8   | ns         |
| IOUT<19:0> or QOUT<19:0> Disable Time from OUTEN<1:0> (Note 7)                            | $t_{\text{IQOD}}$  | -   | 6   | ns         |
| IIN<19:0> or QIN<19:0> Disable Time from CLK (Note 7)                                     | $t_{\text{IQID}}$  | -   | 7   | ns         |



**AC Electrical Specifications**  $V_{CC} = 2.5 \pm 5\%$ ,  $V_{CCIO} = 3.3 \pm 5\%$ ,  $T_A = -40^{\circ}\text{C}$  to  $85^{\circ}\text{C}$  (Note 6) (Continued)

| PARAMETER  | SYMBOL       | MIN | MAX | UNITS |
|--|--------------|-----|-----|-------|
| IIN<19:0> or QIN<19:0> Delay Time from CLK                       | $t_{IQDC}$   | 2   | 7   | ns    |
| IOOUT<19:0> or QOOUT<19:0> Delay Time from CLK                   | $t_{IQODC}$  | 2   | 7   | ns    |
| IIN<19:0> or QIN<19:0> Valid Time from CLK, 2X Rate              | $t_{IQVC2X}$ | 2   | 8   | ns    |
| IOOUT<19:0> or QOOUT<19:0> Valid Time from CLK, 2X Rate          | $t_{IQVC2X}$ | 2   | 8   | ns    |
| SCLK $\bar{X}$ Valid Time from CLK, SCLK $\bar{X}$ = CLK         | $t_{SVC1X}$  | 2   | 7   | ns    |
| SCLK $\bar{X}$ Valid Time from CLK, SCLK $\bar{X}$ = Divided CLK | $t_{SVC}$    | 2   | 7   | ns    |
| ISTRB Delay Time from CLK  | $t_{IDC}$    | 2   | 6   | ns    |
| FSRX Delay Time from CLK   | $t_{FDC}$    | -   | 7   | ns    |
| SYNCO Delay Time from CLK  | $t_{SDC}$    | -   | 9   | ns    |
| P<15:0> Delay Time from CLK                                      | $t_{PDC}$    | -   | 16  | ns    |
| P<15:0> Delay Time from A<6:0> or $\overline{CS}$                | $t_{PDAC}$   | -   | 20  | ns    |
| P<15:0> Delay Time from A<6:0> or $\overline{CS}$ (RDMODE=1)     | $t_{PDAC1}$  | -   | 20  | ns    |
| Output Rise/Fall Time (Note 7)                                   | $t_{RF}$     | -   | 3   | ns    |

NOTES:

- AC tests performed with  $C_L = 70\text{pF}$ . Input reference level for CLK is 1.5V, all other inputs 1.5V. Test  $V_{IH} = 3.0\text{V}$ ,  $V_{IHC} = 3.0\text{V}$ ,  $V_{IL} = 0\text{V}$ ,  $V_{OL} = 1.5\text{V}$ ,  $V_{OH} = 1.5\text{V}$ .
- Controlled via design or process parameters and not directly tested. Characterized upon initial design and at major process or design changes.

**AC Test Load Circuit**

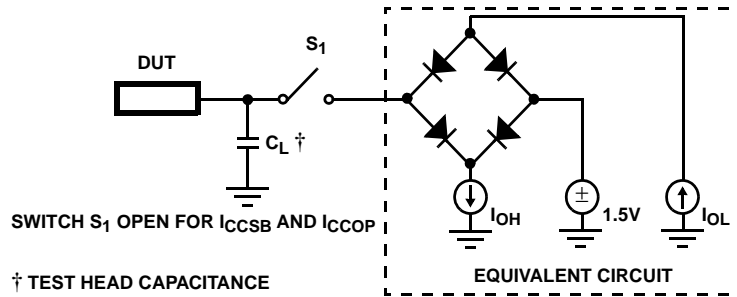

**Waveforms**

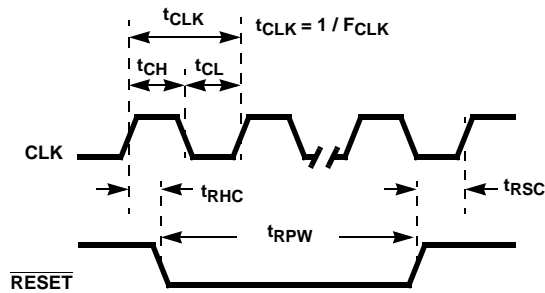

FIGURE 19. CLOCK AND RESET TIMING

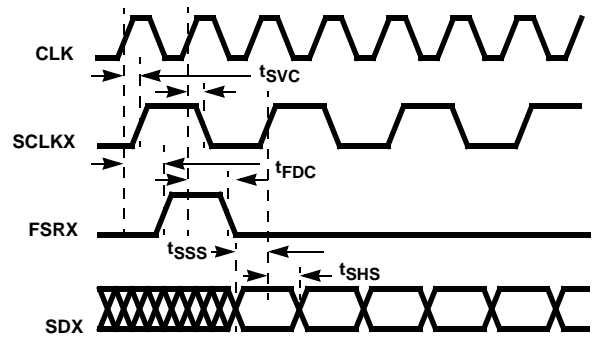

FIGURE 20. SERIAL INTERFACE RELATIVE TIMING

Waveforms (Continued)

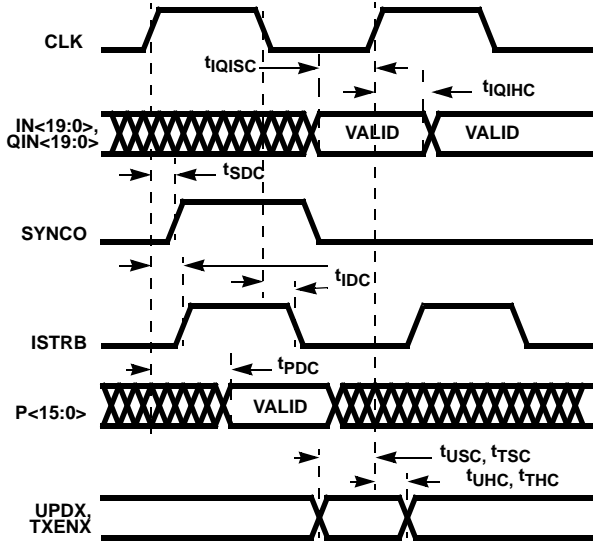

FIGURE 21. INPUT/OUTPUT TIMING

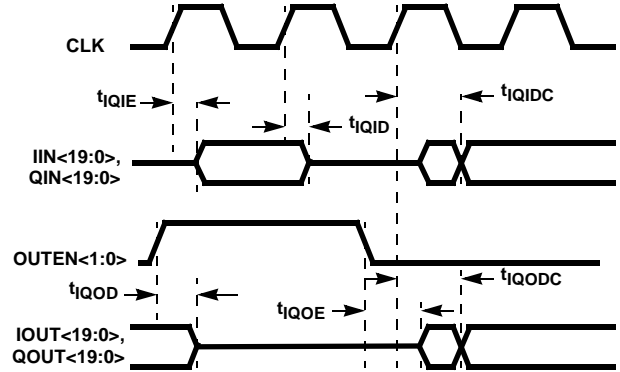

FIGURE 22. ENABLE/DISABLE TIMING

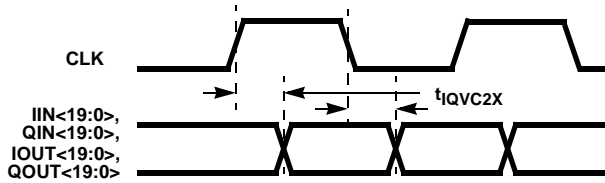

FIGURE 23. MUXED IQ AT 2X OUTPUT TIMING

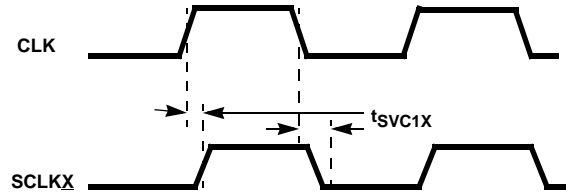

FIGURE 24. SCLKX OUTPUT TIMING IN 1X MODE

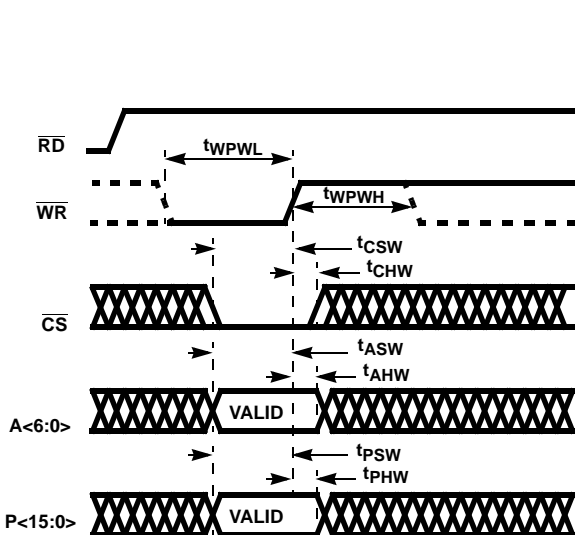

FIGURE 25. MICROPROCESSOR WRITE TIMING (RDmode = 0)

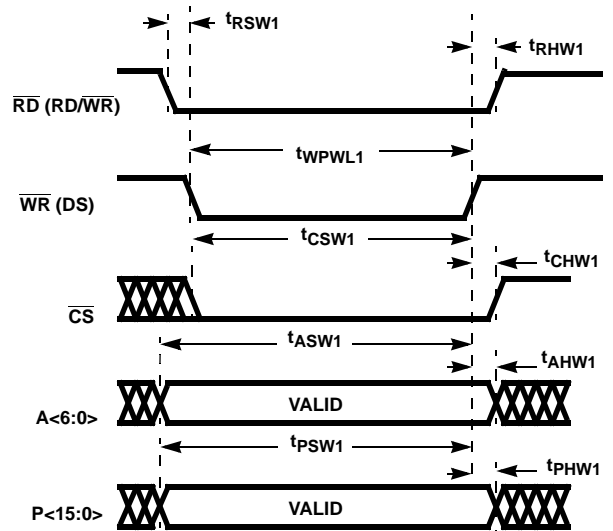

FIGURE 26. MICROPROCESSOR WRITE TIMING (RDmode = 1)

Waveforms (Continued)

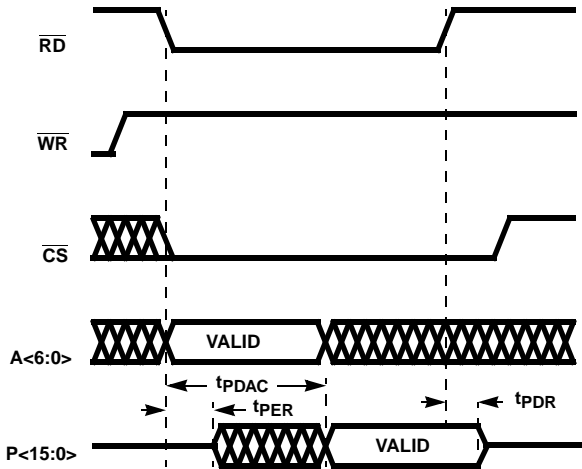

FIGURE 27. MICROPROCESSOR READ TIMING (RDMODE = 0)

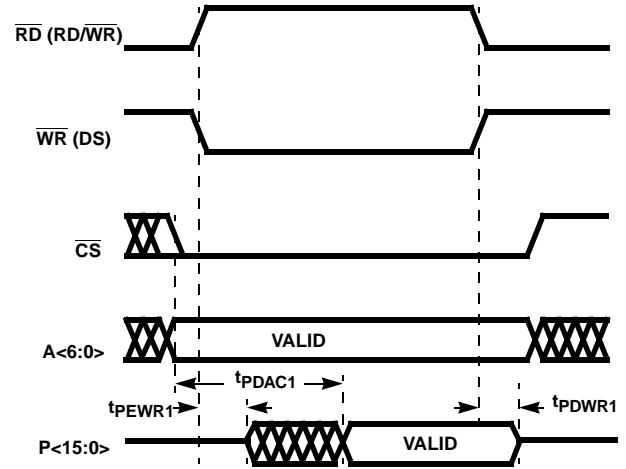

FIGURE 28. MICROPROCESSOR READ TIMING (RDMODE = 1)

Programming Information

TABLE 10. ISL5217 MEMORY MAP

| ADDRESS(6:0)                           | DEVICE MEMORY MAP |
|--|-------------------|
| (000 0000) - (001 0111)<br>0x00 - 0x17 | Channel 0         |
| (001 1000) - (001 1111)<br>0x18 - 0x1f | Undefined         |
| (010 0000) - (011 0111)<br>0x20-0x37   | Channel 1         |
| (011 1000) - (011 1111)<br>0x38 - 0x3f | Undefined         |
| (100 0000) - (101 0111)<br>0x40-0x57   | Channel 2         |
| (101 1000) - (101 1111)<br>0x58 - 0x5f | Undefined         |
| (110 0000) - (111 0111)<br>0x60-0x77   | Channel 3         |
| (111 1000) - (111 1111)<br>0x78-0x7f   | Device control    |

NOTES:

8. Consecutive accesses to the same address require a 4 clock synchronized update to occur before beginning the next accesses.
9. Different direct address locations can be accessed without having to wait for a 4 clock synchronized update to occur.
10. All configuration registers have a master/slave architecture. The master registers are clocked by  $\overline{WR}$ . The slave registers are clocked by CLK.
11. The master registers are writable and cleared by a hard reset. All master registers are located in the SC  $\mu$ P block.
12. The slave registers are readable and cleared by either a hard or soft reset. Refer to the table to determine location of slave registers.
13. Partition indirect address space into pages of 256 words.
14. Decode indirect address <9:8> to determine page, (3 used).
15. Indirect address<14:10> are not used.
16. Indirect address<15> determines access type. 1=read; 0=write.

**Device Control Registers**

**TABLE 11. DEVICE CONTROL REGISTER MAP**

| ADDRESS (6:0)    | TYPE | UPDATE STROBE | SLAVE LOCATION  | FUNCTION                              | RESET DEFAULT |
|------------------|------|---------------|-----------------|---------------------------------------|---------------|
| 11 1 1000 (0x78) | R/W  |               | QC $\mu$ P Intf | Device Control <15:0>.                | 0x0000        |
| 11 1 1001 (0x79) | R/W  | X             | QC $\mu$ P Intf | Device Output Routing Control <15:0>. | 0x0000        |
| 11 1 1010 (0x7a) |      |               |                 | Not Used.                             | -             |
| 11 1 1011 (0x7b) |      |               |                 | Not Used.                             | -             |
| 11 1 1100 (0x7c) |      |               |                 | Not Used.                             | -             |
| 11 1 1101 (0x7d) | R    |               | QC $\mu$ P Intf | Bist And Device Revision Code <15:0>. | 0x0001        |
| 11 1 1110 (0x7e) | R/W  |               | QC $\mu$ P Intf | Device Status <15:0>.                 | 0x0000        |
| 11 1 1111 (0x7f) | W    |               | N/A             | Device Immediate Action <15:0>.       | 0x0000        |

**TABLE 12. BIST and DEVICE REVISION**

| TYPE: DEVICE CONTROL DIRECT, ADDRESS: 0x7d |                 |  |
|--|-----------------|--|
| BIT  | FUNCTION        | DESCRIPTION  |
| 15   | BIST Valid      | Reflects the validity of the Built In Self Test (BIST) signature. The bit is cleared upon assertion or de-assertion of the test mode bit in 0x78, bit 14, and set to one upon completion of the BIST. BIST signature is valid when the bit is one. |
| 14:3                                       | BIST Signature  | Built in self test resultant signature.  |
| 2:0  | Revision Status | Revision status currently 001.   |

NOTE: Bits listed as reserved should be set to 0 for backwards compatibility.

**TABLE 13. DEVICE STATUS**

| TYPE: DEVICE CONTROL DIRECT, ADDRESS: 0x7e |                        |  |
|--|------------------------|--|
| BIT  | FUNCTION               | DESCRIPTION  |
| 15   | CH3 Summary Fault      | FIFO overflow or saturation detected.  |
| 14   | CH2 Summary Fault      | FIFO overflow or saturation detected.  |
| 13   | CH1 Summary Fault      | FIFO overflow or saturation detected.  |
| 12   | CH0 Summary Fault      | FIFO overflow or saturation detected.  |
| 11   | Output Summary Fault   | Saturation detected.   |
| 10   | Reserved               | Not used.  |
| 9  | Cascade I Sat          | Saturation detected, data saturates to most positive value or most negative value + 1. |
| 8  | Cascade Q Sat          | Saturation detected, data saturates to most positive value or most negative value + 1. |
| 7  | Output Summer 4, I Sat | Saturation detected, data saturates to most positive value or most negative value + 1. |
| 6  | Output Summer 4, Q Sat | Saturation detected, data saturates to most positive value or most negative value + 1. |
| 5  | Output Summer 3, I Sat | Saturation detected, data saturates to most positive value or most negative value + 1. |
| 4  | Output Summer 3, Q Sat | Saturation detected, data saturates to most positive value or most negative value + 1. |
| 3  | Output Summer 2, I Sat | Saturation detected, data saturates to most positive value or most negative value + 1. |
| 2  | Output Summer 2, Q Sat | Saturation detected, data saturates to most positive value or most negative value + 1. |
| 1  | Output Summer 1, I Sat | Saturation detected, data saturates to most positive value or most negative value + 1. |
| 0  | Output Summer 1, Q Sat | Saturation detected, data saturates to most positive value or most negative value + 1. |

**NOTES:**

- 17. Channel summary fault is the logical or'ing of channel status <10:7,3>.
- 18. Clear fault by writing "1" to each summary fault bit (15:11).
- 19. Channel summary status is cleared as well as the Channel status word.
- 20. Output summary fault clears top status bits <9:0>.

TABLE 14. DEVICE IMMEDIATE ACTION

| TYPE: DEVICE CONTROL DIRECT, ADDRESS: 0x7f |          |  |
|--|----------|--|
| BIT  | FUNCTION | DESCRIPTION  |
| 15:2                                       | Reserved | Not Used.  |
| 1  | Reset    | Hard Reset. Self clearing pulse zeroes data RAMs, returns master and slave configuration registers to their default values, etc. The device is in an idle state after reset. |
| 0  | Sync Out | Software Sync Out. Self clearing pulse used to synchronize multiple devices. See Figure 3.   |

**Single Channel Direct Control Registers**

TABLE 15. SINGLE CHANNEL DIRECT REGISTER MAP

| DIRECT ADDRESS (4:0) | TYPE | UPDATE STROBE | ALWAYS UPDATE IMMEDIATE | SLAVE LOCATION                                      | FUNCTION                                 | RESET DEFAULT |
|----------------------|------|---------------|-------------------------|---|--|---------------|
| 00                   | R/W  | X             | X                       | FIFO  | I Channel Input or FM <15:0>.            | -             |
| 01                   | R/W  |               | X                       | FIFO  | Q Channel input <15:0>.                  | -             |
| 02                   | R/W  |               |                         | Sample NCO  | Fixed Integer divider <31:16> MSW.       | 0x0000        |
| 03                   | R/W  | X             |                         | Sample NCO  | Fixed Integer divider <15:0> LSW.        | 0x0000        |
| 04                   | R/W  |               |                         | Sample NCO  | Sample Freq <47:32>, MSW.                | 0x0000        |
| 05                   | R/W  |               |                         | Sample NCO  | Sample Freq <31:16>.                     | 0x0000        |
| 06                   | R/W  | X             |                         | Sample NCO  | Sample Freq <15:0>, LSW.                 | 0x0000        |
| 07                   | R/W  | X             |                         | Carrier NCO   | Carrier Freq static phase offset <15:0>. | 0x0000        |
| 08                   | R/W  |               |                         | Carrier NCO   | Carrier Freq MSW <15:0>.                 | 0x0000        |
| 09                   | R/W  | X             |                         | Carrier NCO   | Carrier Freq LSW <15:0>.                 | 0x0000        |
| 0a                   | R/W  | X             |                         | Final Gain  | Gain <15:0>.                             | 0x0000        |
| 0b                   | R/W  |               | X                       | μP Interface  | Gain Profile length <8:0>.               | 0x0000        |
| 0c                   | R/W  |               | X                       | μP Interface  | Main Control <15:0>.                     | 0x0000        |
| 0d                   | R/W  | X             |                         | Timing and Cntrl, Sample NCO, IQ FIFO, FIR and Gain | FIR Control <15:0>.                      | 0x0000        |
| 0e                   | R/W  |               | X                       | μP Interface  | Update Mask <15:0>.                      | 0x0000        |
| 0f                   | W    |               |                         | μP Interface  | Immediate Action<15:0>.                  | 0x0000        |
| 10                   | R/W  |               | X                       | μP Interface  | Polarity Control<15:0>.                  | 0x0000        |
| 11                   | R/W  | X             |                         | Timing and Cntrl, Serial Interface                  | Serial Control <15:0>.                   | 0x0000        |
| 12                   | R/W  | X             |                         | Serial Interface                                    | I Serial Time slot<15:0>.                | 0x0000        |
| 13                   | R/W  | X             |                         | Serial Interface                                    | Q Serial Time slot<15:0>.                | 0x0000        |
| 14                   | W    |               |                         | μP Interface  | RAM Data <15:0>.                         | 0x0000        |
| 15                   | W    | X             |                         | μP Interface  | RAM Address <15:0>.                      | -             |
| 16                   | R    |               |                         | μP Interface  | Status <15:0>.                           | 0x0000        |
| 17                   | R/W  |               | X                       | μP Interface  | Test Control<15:0>.                      | 0x0000        |
| 18:1F                |      |               |                         |   | Not Used.                                | 0x0000        |

TABLE 16. I CHANNEL INPUT OR FM (15:0)

| TYPE: SINGLE CHANNEL DIRECT, ADDRESS: 0x00 |                                  |   |
|--|----------------------------------|---|
| BIT  | FUNCTION                         | DESCRIPTION   |
| 15:0                                       | I Channel QASK Input or FM Input | I(15:0). In QASK mode, this is the I input vector. The format is 2's complement. The MSB is bit 15. The mixer operation is:<br>$OUT = (I * \cos) - (Q * \sin)$ .<br>In FM mode, this is interpreted as an offset frequency to the center frequency. The modulation index depends on the mode and the filter coefficients. In FM with post filter mode, the phase change per input sample can range from -180 to 180 degrees, so the deviation is limited to $\pm(\text{input sample rate})/2$ . |

TABLE 17. Q CHANNEL INPUT (15:0)

| TYPE: SINGLE CHANNEL DIRECT, ADDRESS: 0x01 |                 |   |
|--|-----------------|---|
| BIT  | FUNCTION        | DESCRIPTION   |
| 15:0                                       | Q Channel Input | Q(15:0). In QASK mode, this is the Q input vector. See address 0 above. In FM mode, this input is not used. |

NOTE: Writing to the I channel input generates the update strobe to move the data into the IQ FIFO. Normal write order is Q then I.

TABLE 18. FIXED INTEGER DIVIDER, MSW

| TYPE: SINGLE CHANNEL DIRECT, ADDRESS: 0x02 |                       |  |
|--|-----------------------|--|
| BIT  | FUNCTION              | DESCRIPTION  |
| 15:0                                       | Fixed Integer Divider | FID(31:16) is loaded in this address. See Address 3. |

TABLE 19. FIXED INTEGER DIVIDER, LSW

| TYPE: SINGLE CHANNEL DIRECT, ADDRESS: 0x03 |                       |  |
|--|-----------------------|--|
| BIT  | FUNCTION              | DESCRIPTION  |
| 15:0                                       | Fixed Integer Divider | FID(15:0) is loaded in this address. The fixed integer divider is a 32 bit counter clocked at the output clock rate. The carryout is used to clear the fine and /or coarse phase of the sample rate NCO. Allows fixed integer sample rates. The fixed integer divider is computed by the formula:<br>$FID(31:0) = \text{INT} [f_{CLK} / f_{CO}]$ |

NOTE: Writing to the LSW generates the update strobe to load the slave configuration reg when in the immediate mode

TABLE 20. SAMPLE FREQUENCY (47:32) MSW

| TYPE: SINGLE CHANNEL DIRECT, ADDRESS: 0x04 |                 |   |
|--|-----------------|---|
| BIT  | FUNCTION        | DESCRIPTION   |
| 15:0                                       | Sample Rate NCO | SF(47:32) is loaded in this address. See Address 6. |

TABLE 21. SAMPLE FREQUENCY (31:16)

| TYPE: SINGLE CHANNEL DIRECT, ADDRESS: 0x05 |                 |   |
|--|-----------------|---|
| BIT  | FUNCTION        | DESCRIPTION   |
| 15:0                                       | Sample Rate NCO | SF(31:16) is loaded in this address. See Address 6. |

TABLE 22. SAMPLE FREQUENCY (15:0) LSW

| TYPE: SINGLE CHANNEL DIRECT, ADDRESS: 0x06 |                 |   |
|--|-----------------|---|
| BIT  | FUNCTION        | DESCRIPTION   |
| 15:0                                       | Sample Rate NCO | SF(15:0) is loaded in this address. The sample rate is controlled by a 48-bit NCO clocked at the output clock rate. The sample rate is computed by the formula:<br>$SF(47:0) = \text{INT} [(f_s / f_{CLK}) * 2^{48}]$ |

NOTE: Writing to the LSW generates the update strobe to load the slave configuration reg when in the immediate mode.

TABLE 23. CARRIER PHASE OFFSET (15:0)

| TYPE: SINGLE CHANNEL DIRECT, ADDRESS: 0x07 |                      |   |
|--|----------------------|---|
| BIT  | FUNCTION             | DESCRIPTION   |
| 15:0                                       | Carrier Phase Offset | Initializes the most-significant 16-bits of the phase accumulator. The carrier phase offset is computed by the formula:<br>Carrier Phase Offset (15:0) = INT [(Phase Offset 0 / 3600 * 2 <sup>32</sup> ) / 216] |

TABLE 24. CARRIER FREQUENCY (31:16) MSW

| TYPE: SINGLE CHANNEL DIRECT, ADDRESS: 0x08 |             |                                      |
|--|-------------|--------------------------------------|
| BIT  | FUNCTION    | DESCRIPTION                          |
| 15:0                                       | Carrier NCO | CF(31:16) is loaded in this address. |

TABLE 25. CARRIER FREQUENCY (15:0) LSW

| TYPE: SINGLE CHANNEL DIRECT, ADDRESS: 0x09 |             |  |
|--|-------------|--|
| BIT  | FUNCTION    | DESCRIPTION  |
| 15:0                                       | Carrier NCO | CF(15:0) is loaded in this address. The SIN/COS generator is controlled by a 32-bit NCO clocked at the output clock rate. The center frequency is computed by the formula:<br>$f_C = CF(31:0) \times f_{CLK} \times 2^{-32}$ ; $CF(31:0) = INT(f_C / f_{CLK} \times 2^{32})$ . |

NOTE: Writing to the LSW generates the update strobe to load the slave configuration reg when in the immediate mode

TABLE 26. GAIN

| TYPE: SINGLE CHANNEL DIRECT, ADDRESS: 0x0a |                          |   |
|--|--------------------------|---|
| BIT  | FUNCTION                 | DESCRIPTION   |
| 15   | Reserved                 | Not Used.   |
| 14:12                                      | Step Atten (2:0)         | Select 1 of 8 fixed attenuations<br>000 - scale by 4096<br>001 - scale by 256<br>010 - scale by 32<br>011 - scale by 16<br>100 - scale by 8<br>101 - scale by 4<br>110 - scale by 2<br>111 - scale by 1   |
| 11:0                                       | Unsigned Gain Multiplier | The gain multiplier is computed by the formula:<br>$Gain(11:0) = [10 \lfloor (Gain(db) / 20 \rfloor 2^{12}) \rfloor_{Hex}$<br>Bit weight. 2 <sup>-1</sup> 2 <sup>-2</sup> ... 2 <sup>-12</sup><br>Maximum 0xFFF = 1.0 - 2 <sup>-12</sup> = 0.9998<br>0x800 = 0.5<br>0x001 = 2 <sup>-12</sup><br>Minimum 0x000 = 0.0 |

TABLE 27. GAIN PROFILE

| TYPE: SINGLE CHANNEL DIRECT, ADDRESS: 0x0b |                      |   |
|--|----------------------|---|
| BIT  | FUNCTION             | DESCRIPTION   |
| 8:7  | Gain Profile Latency | Set bit 7 high to remove two edge latencies from the delay path. This should be combined DS=3, IP=4 settings to provide perfect symmetry through the gain block. Set bit 8 high to bypass all latency alignment circuitry and to use TXEN <sub>X</sub> as input to the channel. |
| 6:0  | Gain Profile Length  | Set to the upper address used for the gain profile RAM.   |



TABLE 28. MAIN CONTROL

| TYPE: SINGLE CHANNEL DIRECT, ADDRESS: 0x0c |                                       |   |
|--|---------------------------------------|---|
| BIT  | FUNCTION                              | DESCRIPTION   |
| 15   | Immediate Update (sc conf reg update) | 0 = Allows the configuration slave registers to be synchronously updated based the update mask.<br>1 = Allows $\mu$ P writes to bypass the update mask and load the selected configuration slave register immediately from the master, (requires 4 clk synchronization).  |
| 14   | Gain Profile Hold                     | Allows $\mu$ P access to the gain profile RAM. Upon assertion the device will hold the last address and gain value from the ramp. When deasserted, the gain profile RAM output returns to the ramp address and value currently loaded. Normal access would be to re-load the coefficients with the gain profile RAM ramping function having completed (either up or down).<br>0 = normal access by the hardware.<br>1 = $\mu$ P access for loading the gain profile coefficients. |
| 13   | Delay Select                          | 0 = no delay.<br>1 = 1/2 coarse sample delay inserted in the I/Q path after the FIR.  |
| 12   | $\mu$ P Hold                          | Allows $\mu$ P access to the I and Q coefficient RAMs.<br>0 = normal access by the hardware.<br>1 = $\mu$ P access for loading filter coefficients.   |
| 11   | TXEN $\bar{X}$ Control                | Set to one to enable the internal generation and control of TXEN $\bar{X}$ based on the programmed values of indirect registers 0x400-0x404 and 0x407. Set to zero (default) to input TXEN $\bar{X}$ externally.  |
| 10:8                                       | Almost Empty Threshold (2:0)          | Almost Empty Threshold (2:0). FIFO depth threshold (number of data samples in the FIFO - 1) at which the Almost Empty flag will be asserted, alerting the data source that more input data is required in the FIFO. The FIFO threshold sets both the I and Q FIFO thresholds. (2) is the MSB.   |
| 7  | Complex Output Mode                   | Allows complex data out at the full rate when in 4-ch re output mode. The effect of this setting depends on the channel.<br>CH 0 = Over-rides selection of re sum2 and selects im sum1 for output.<br>CH 1 = n/a.<br>CH 2 = Over-rides selection of re sum4 and selects im sum3 for output.<br>CH 3 = n/a.  |
| 6  | On-Line Mode                          | 0 = Off line - zeroes data from FIFO - (reset FIFO cntrl forces rd_addr to 0 which selects zero value data for I and Q) This takes 24 sample-clocks to flush the channel. The status bit CH FLUSHED will be asserted when complete.<br>1 = On line - allows normal operation of the IQ FIFO's.  |
| 5  | Input En                              | Enables input of selected hw TX_enable and hw Update.   |
| 4  | Channel Output En                     | 0 = Disables output of channel, clears data to zero.<br>1 = Enables output of channel. Passes data.   |
| 3  | TXEN $\bar{X}$ SIB Control            | Disables TXEN $\bar{X}$ control of the Serial Interface Block (SIB) and allows it to continue running independent of the TXEN $\bar{X}$ signal. Data input should be zeroed during TXEN $\bar{X}$ low time, as the data will continue to be processed by the SIB.<br>0 = normal TXEN $\bar{X}$ control of SIB.<br>1 = TXEN $\bar{X}$ SIB control disabled.  |
| 2  | TXEN $\bar{X}$ Channel Flush          | Disables TXEN $\bar{X}$ control of the channel flushing. Setting this bit will stop the device from flushing the channel and FIR data RAM with zeroes upon the rising edge of TXEN $\bar{X}$ .<br>0 = normal TXEN $\bar{X}$ channel flushing.<br>1 = TXEN $\bar{X}$ will not flush the channel.   |
| 1  | FIFO Overflow Reset                   | Disables the FIFO overflow channel reset function. This is only applicable in the parallel input mode.<br>0 = normal FIFO overflow channel reset.<br>1 = FIFO overflow channel reset disabled.  |
| 0  | Sw TX Enable                          | Rising edge flushes data RAM, (16 clks) and updates configuration slave registers as determined by the update mask. High level allows serial requests to occur. Low level inhibits additional serial data requests, (assertion TX frame strobe).  |

TABLE 29. FIR CONTROL

| TYPE: SINGLE CHANNEL DIRECT, ADDRESS: 0x0d |                            |   |
|--|----------------------------|---|
| BIT  | FUNCTION                   | DESCRIPTION   |
| 15   | Gain Profile Mode          | Enables gain profile to slew gain value during transitions of TX enable   |
| 14   | Clear Sample Phase         | When enabled will clear sample phase on immediate update of sample frequency<br>0 = maintain sample phase<br>1 = clear sample phase.  |
| 13   | FM_Mode Disable            | Set to 1 to disable the internal FM_Mode signal to the serial interface block. This keeps the I/Q input sample alignment such that the serial interface block expects both the I and Q time slot counters to count down to 0 prior to transferring the I/Q samples to the FIFO. Loss of synchronization of the I/Q samples can occur when switching FM modes without this bit set.    |
| 12   | Fixed Integer Mode         | Enables the fixed integer divider in the sample rate NCO  |
| 11:10                                      | Phase Offset (1:0)         | The phase accumulator of the sample rate NCO can be offset by increments of 90 degrees.<br>00 = 0°<br>01 = 90°<br>10 = 180°<br>11 = 270°  |
| 9  | Half Band Filter Enable    | 0=Half Band filter bypassed (default).<br>1=Half Band filter enabled.   |
| 8  | Coefficient Switch         | Selects second filter coefficients in coefficient RAM.  |
| 7:4  | Data Span (3:0)            | Data Span(3:0). Number of data samples in shaping filter, 4-16. Load with number of data samples minus 1.   |
| 3:2  | Modulation Type (1:0)      | Modulation type(1:0)<br>00 = QASK - PSK or QAM modulation.<br>01 = FM post-filtering - Analog FM modulation. Filtering after FM modulation (baseband filtering provided before ISL5217). In this mode both I and Q filters are used.<br>10 = FM pre-filtering - FSK, GMSK modulation. Filtering before FM modulation. In this mode, only the I filter is used.<br>11 = Invalid state. |
| 1:0  | Interpolation Phases (1:0) | Interpolation Phases(1:0) Number of coarse interpolation phases:<br>00 = forces coarse and fine phase to zero.<br>01 = 4.<br>10 = 8.<br>11 = 16.  |

NOTES:

21. QASK mode data flow - FIFO -> shaping filter -> interpolating filter
22. FM post mode data flow - FIFO -> FM modulator -> shaping filter -> interpolating filter
23. FM pre mode data flow - FIFO -> shaping filter -> FM modulator -> interpolating filter
24. The Q FIFO is not used when in the FM mode.

TABLE 30. UPDATE MASK

| TYPE: SINGLE CHANNEL DIRECT, ADDRESS: 0x0e |                                   |   |
|--|-----------------------------------|---|
| BIT  | FUNCTION                          | DESCRIPTION   |
| 15   | PN-Generator                      | 1 = update, 0 = no update. PN-Generator is synchronously reset via the channel 0 UPD $\bar{X}$ signal anded with this mask bit. |
| 14:11                                      | Reserved                          | Not Used.   |
| 10   | Serial Control, I and Q Time Slot | 1 = Update, 0 = No Update.  |
| 9  | FIR control                       |   |
| 8  | Gain                              |   |
| 7  | Carrier Phase                     |   |
| 6  | Carrier Freq                      |   |

TABLE 30. UPDATE MASK (Continued)

| TYPE: SINGLE CHANNEL DIRECT, ADDRESS: 0x0e |                     |                            |
|--|---------------------|----------------------------|
| BIT  | FUNCTION            | DESCRIPTION                |
| 5  | Sample Rate Divider |                            |
| 4  | Sample Rate Freq    |                            |
| 3  | Sample Fine Phase   |                            |
| 2  | Sample Coarse Phase |                            |
| 1  | Routing Control     |                            |
| 0  | I Strobe            | 1 = Update, 0 = No Update. |

NOTES:

- 25. The mask register enables the slave registers to be updated from a hardware or software strobe.
- 26. The mask register is not used when  $\mu P$  is updating a configuration slave register immediately.
- 27. There is no immediate update on the I strobe.
- 28. Update mask <1> only affects the top routing control nibble for this channel.

TABLE 31. IMMEDIATE ACTION

| TYPE: SINGLE CHANNEL DIRECT, ADDRESS: 0x0f |                                  |   |
|--|----------------------------------|---|
| BIT  | FUNCTION                         | DESCRIPTION   |
| 15:2                                       | Reserved                         | Not used  |
| 1  | Soft Reset (Channel Reset)       | Soft reset. Self clearing pulse zeroes FIFO's, zeroes data RAMs, and clears all but the master registers. The device will reload the slave configuration registers on the next TX enable or update strobe |
| 0  | Software Update (General Update) | Software update Self clearing pulse allows $\mu P$ write to load all configuration slave registers synchronously as determined by the update mask. The software equivalent of the hardware Update strobe  |

TABLE 32. POLARITY CONTROL









| TYPE: SINGLE CHANNEL DIRECT, ADDRESS: 0x10 |                     |  |
|--|---------------------|--|
| BIT  | FUNCTION            | DESCRIPTION  |
| 15:4                                       | Reserved            | N/A  |
| 3  | Tx Enable Polarity  | <p>Tx enable polarity</p> <p>0 = defines an assertion as a transition from a logic low to a logic high</p> <p>1 = defines an assertion as a transition from a logic high to a logic low</p> <p style="text-align: center;">0 =  1 = </p>     |
| 2  | Update Polarity     | <p>Update polarity.</p> <p>0 = defines an assertion as a transition from a logic low to a logic high</p> <p>1 = defines an assertion as a transition from a logic high to a logic low</p> <p style="text-align: center;">0 =  1 = </p>       |
| 1  | FSR Polarity        | <p>Frame strobe polarity.</p> <p>0 = defines an assertion as a transition from a logic low to a logic high</p> <p>1 = defines an assertion as a transition from a logic high to a logic low</p> <p style="text-align: center;">0 =  1 = </p> |
| 0  | Serial CLK Polarity | <p>Serial clk polarity.</p> <p>0 = defines an assertion as a transition from a logic low to a logic high</p> <p>1 = defines an assertion as a transition from a logic high to a logic low</p> <p style="text-align: center;">0 =  1 = </p>   |

TABLE 33. SERIAL CONTROL (13:0)

| TYPE: SINGLE CHANNEL DIRECT, ADDRESS: 0x11 |                             |   |
|--|-----------------------------|---|
| BIT  | FUNCTION                    | DESCRIPTION   |
| 15   | Serial/parallel Data Select | Selects the source of the symbol data for input.<br>0 = $\mu$ P port, (parallel interface)<br>1 = serial port, (one of four serial ports)   |
| 14   | Epoch Frame Strobe Enable   | Selects a pre-carry out of the fixed integer divider instead of the serial frame strobe. The pre-carry out is six clocks ahead of the true carry out. This strobe is used to synchronize fixed integer dividers on other devices.<br>0 = serial frame strobe.<br>1 = epoch frame strobe.  |
| 13:10                                      | Serial Clock Rate (3:0)     | Clock divider to generate 1 of 16 serial clock rates<br>0000 = clk/2                      1101 = clk/28<br>0001 = clk/4                      1110 = clk/30<br>0010 = clk/6                      1111 = clk/32   |
| 9:8  | Serial Clock Mode (1:0)     | Selects the source for serial TX clock output.<br>00 = Disables serial clock divider and serial clock out.<br>01 = Select 1x clock rate.<br>10 = Select divided clock rate.<br>11 = Select 32x sample clock rate.   |
| 7:6  | Select TX Enable (1:0)      | Selects the TX enable port. The rising edge flushes data, (16 clks) and updates configuration slave registers as determined by the update mask. High level allows serial requests to occur. Low level inhibits additional serial data requests, (assertion of TX frame strobe).<br>00 = TX enable A.<br>01 = TX enable B.<br>10 = TX enable C.<br>11 = TX enable D. |
| 5:4  | Select Update(1:0)          | Selects the Update port. The Update strobe is used to update all slave configuration registers as determined by the update mask.<br>00 = Update A.<br>01 = Update B.<br>10 = Update C.<br>11 = Update D.  |
| 3:2  | Serial Word Length (1:0)    | Selects the word length of the incoming serial data The value is for one data word and is the same for both I and Q data.<br>00 = 16 bits.<br>01 = 12 bits.<br>10 = 8 bits.<br>11 = 4 bits.   |
| 1:0  | Select Serial Data in (1:0) | Selects the serial data in port.<br>00 = Serial data A.<br>01 = Serial data B.<br>10 = Serial data C.<br>11 = Serial data D.  |

TABLE 34. I - SERIAL TIME SLOT

| TYPE: SINGLE CHANNEL DIRECT, ADDRESS: 0x12 |                  |  |
|--|------------------|--|
| BIT  | FUNCTION         | DESCRIPTION  |
| 15:10                                      | Reserved         | Not Used.  |
| 9:0  | I Time Slot(9:0) | The I - SERIAL TIME SLOT is a 10 bit counter clocked at the serial clock rate. The counter begins on assertion of the Frame strobe. The carryout determines when a valid I symbol has been shifted in. |

TABLE 35. Q - SERIAL TIME SLOT

| TYPE: SINGLE CHANNEL DIRECT, ADDRESS: 0x13 |                   |  |
|--|-------------------|--|
| BIT  | FUNCTION          | DESCRIPTION  |
| 15:10                                      | Reserved          | Not Used.  |
| 9:0  | Q Time Slot (9:0) | The Q - SERIAL TIME SLOT is a 10 bit counter clocked at the serial clock rate. The counter begins on assertion of the Frame strobe. The carryout determines when a valid Q symbol has been shifted in. |

TABLE 35. Q - SERIAL TIME SLOT (Continued)

| TYPE: SINGLE CHANNEL DIRECT, ADDRESS: 0x13 |          |             |
|--|----------|-------------|
| BIT  | FUNCTION | DESCRIPTION |

## NOTES:

29. When in the QASK mode, the I and Q symbols will not be moved into the FIFO until both have been received.  
 30. When in the FM mode, the I symbol is moved to the FIFO after it has been shifted in.  
 31. The order of the I and Q symbols is based on the I and Q time slot values.

TABLE 36. RAM DATA (15:0)

| TYPE: SINGLE CHANNEL DIRECT, ADDRESS: 0x14 |          |   |
|--|----------|---|
| BIT  | FUNCTION | DESCRIPTION   |
| 15:0                                       | RAM Data | Indirect data port for the Gain profile, I and Q coefficients RAMs. |

TABLE 37. RAM ADDRESS (15:0)

| TYPE: SINGLE CHANNEL DIRECT, ADDRESS: 0x15 |             |   |
|--|-------------|---|
| BIT  | FUNCTION    | DESCRIPTION   |
| 15:0                                       | RAM Address | Indirect address port for the Gain profile, I and Q coefficients RAMs. The MSB determines the type of access. 1 = read 0 = write. |

TABLE 38. STATUS (15:0)

| TYPE: SINGLE CHANNEL DIRECT, ADDRESS: 0x16 |                            |   |
|--|----------------------------|---|
| BIT  | FUNCTION                   | DESCRIPTION   |
| 15:12                                      | Reserved                   | Not Used.   |
| 11   | Channel Flushed            | Indicates zero valued data has propagated through the channel after entering the off-line mode. Counts 24 consecutive FIFO reads after deassertion of on-line control bit, Main Control, 0x0C, bit 6. |
| 10   | I FIR Overflow             | I FIR accumulator output saturates to most positive value.  |
| 9  | I FIR Underflow            | I FIR accumulator output saturates to most negative value + 1.  |
| 8  | Q FIR Overflow             | Q FIR accumulator output saturates to most positive value.  |
| 7  | Q FIR Underflow            | Q FIR accumulator output saturates to most negative value + 1.  |
| 6:4  | FIFO Read Address<br><2:0> | FIFO read address range 0 to 7, 0 = empty, 7 = full.  |
| 3  | FIFO Underflow             | FIFO read address = 0, FIFO write =0, FIFO read =1.   |
| 2  | FIFO Overflow              | FIFO read address = 7.  |
| 1  | FIFO Almost Empty          | FIFO read address < Almost empty threshold.   |
| 0  | FIFO Empty                 | FIFO read address = 0.  |

## NOTES:

32. Status bits <10:7,3> are or'ed and latched by the Top  $\mu$ P interface.  
 33. Status bits <11:0> are latched by the single channel  $\mu$ P interface.  
 34. The status register is cleared by writing to the Top status register.  
 35. Detection of FIFO overflow puts the channel in the off-line mode.  
 36. The Channel flushed status is asserted 24 sample clocks after entering the off-line mode.

## Single Channel Indirect Registers

**TABLE 39. SINGLE CHANNEL INDIRECT REGISTER MAP**

| INDIRECT ADDRESS | Page | Type | Update strobe | Slave location | FUNCTION  |
|------------------|------|------|---------------|----------------|---|
| 000 .. 07F       | 0    | R/W  |               |                | Gain profile  |
| 080 .. 0FF       | 0    |      |               |                | Not used  |
| 100 .. 1FF       | 1    | R/W  |               |                | Read I coefficients.<br>Write I and Q shaping filter coefficients when I and Q are not equal. |
| 200 .. 2FF       | 2    |      |               |                | Not Used.   |
| 300 .. 3FF       | 3    | R/W  |               |                | Read Q coefficients.<br>Write I and Q shaping filter coefficients when I and Q are equal.     |
| 400 .. 407       | 4    | R/W  |               |                | TXEN <sub>X</sub> programmed cycle values.  |
| 408 .. 4FF       | 4-F  |      |               |                | Not Used.   |

**TABLE 40. GAIN PROFILE (15:0)**

| TYPE: SINGLE CHANNEL INDIRECT, ADDRESS RANGE: 0x000-0x07f (PAGE 0) |              |  |
|--|--------------|--|
| BIT  | FUNCTION     | DESCRIPTION  |
| 15:12  | Reserved     | Not Used.  |
| 11:0   | Gain profile | 128 location RAM that multiplies the channel gain in incremental steps at the coarse phase rate. The gain profile is enabled by control word 0x0d[15]. The address is reset to zero on assertion of the gain profile enable. The address is incremented by one with each change in coarse phase after assertion of the TX enable. The address is held upon reaching the upper address used for the gain profile RAM, Gain profile length 0x0b. On deassertion of the TX enable the gain profile address is decremented back to zero.<br><br>Bit weight $2^0, 2^{-1}, 2^{-2}, \dots, 2^{-11}$<br>Maximum 0x800 = 1.0<br>0x001 = 2 <sup>-11</sup><br>Minimum 0x000 = 0.0 |

**NOTES:**

- The contents of the last used location must be 0x800, (specified by the gain profile length).

**Write** access to the Gain Profile RAM:

- Enable the gain profile hold mode by setting bit 14 of the Main Control register 0x0c.
- Load the RAM data to location 0x14.
- Load the RAM write address to location 0x15. A write strobe transfers the contents of the register at location 0x14 into the RAM location specified by the contents of the register at location 0x15. (Indirect address[15] = 0).
- Wait 4 clock cycles before performing the next write to the RAM data register.
- Repeat steps 2-4.
- Return gain control back to the channel by disabling the gain profile hold 0x0c, bit 14.

**Read** access to the Gain Profile:

- Enable the gain profile hold mode by setting bit 14 of the Main Control register 0x0c.
- Load the RAM read address and 0x8000 to location 0x15. A read strobe transfers the contents of the RAM location specified by the contents of the register at location 0x15 onto the read bus. (Indirect address[15] = 1, Indirect address[9:8] = '00').
- Wait 4 clock cycles before performing the next write to the RAM address register.
- Repeat steps 2-3.
- Return gain control back to the channel by disabling the gain profile hold 0x0c, bit 14.

TABLE 41. I AND Q CHANNEL COEFFICIENTS (15:0)

| TYPE: SINGLE CHANNEL INDIRECT, ADDRESS RANGE: 0x100-0x1ff (PAGE 1) |                    |  |
|--|--------------------|--|
| BIT  | FUNCTION           | DESCRIPTION  |
| 15:0   | Filter coefficient | 256 location RAM. Use this page when the I and Q coefficients are different. |

## NOTES:

**Coefficients RAM Read/Write Procedure (16-bit 2's complement format)****Write** access to the Coefficient RAMs when I not equal Q:

1. Enable the  $\mu$ P hold mode by setting bit 12 of the Main Control register 0x0c.
2. Load the RAM data to location 0x14 with the Q coefficient
3. Load the RAM data to location 0x14 with the I coefficient
4. Load the RAM write address to location 0x15. A write strobe transfers the contents of the register at location 0x14 into the RAM location specified by the contents of the register at location 0x15. (Indirect address[15] =0, Indirect address[9:8]='01').
5. Wait 4 clock cycles before performing the next write to the RAM data register.
6. Repeat steps 2-5.
7. Return RAM control back to the channel by disabling the  $\mu$ P hold mode.

**Read** access to the I Coefficient RAM:

1. Enable the  $\mu$ P hold mode by setting bit 12 of the Main Control register 0x0c.
2. Load the RAM read address to location 0x15. A read strobe transfers the contents of the RAM location specified by the contents of the register at location 0x15 onto the read bus. (Indirect address[15] =1, Indirect address[9:8]='01').
3. Wait 4 clock cycles before performing the next write to the RAM address register.
4. Repeat steps 2-3.
5. Return RAM control back to the channel by disabling the  $\mu$ P hold mode.

**Read** access to the Q Coefficient RAM:

1. Enable the  $\mu$ P hold mode by setting bit 12 of the Main Control register 0x0c.
2. Load the RAM read address to location 0x15. A read strobe transfers the contents of the RAM location specified by the contents of the register at location 0x15 onto the read bus. (Indirect address[15] =1, Indirect address[9:8]='10').
3. Wait 4 clock cycles before performing the next write to the RAM address register.
4. After all data has been loaded, return RAM control back to the channel by disabling the  $\mu$ P hold mode

**Coefficients RAM Read/Write Procedure (24-bit floating point format)****Write** access to the Coefficient RAMs:

1. Enable the  $\mu$ P hold mode by setting bit 12 of the Main Control register 0x0c.
2. Load the RAM data to location 0x14 with the iCoef<3:0>, iShift<3:0>, qCoef<3:0>, qShift<3:0>.
3. Load the RAM data to location 0x14 with the qCoef<19:4>.
4. Load the RAM data to location 0x14 with the iCoef<19:4>.
5. Load the RAM write address to location 0x15. A write strobe transfers the contents of the three previously loaded registers at location 0x14 into the RAM location specified by the contents of the register at location 0x15. (Indirect address[15] =0, Indirect address[9:8] = '01').
6. Wait 4 clock cycles before performing the next write to the RAM data register.
7. Repeat steps 2-6.
8. Return RAM control back to the channel by disabling the  $\mu$ P hold mode.

**Read** access to the Coefficient RAM:

1. Enable the  $\mu$ P hold mode by setting bit 12 of the Main Control register 0x0c.
2. Load the RAM read address to location 0x15. Three read strobes are required to transfers the contents of the RAM location specified by the contents of the register at location 0x15 onto the read bus. Indirect address[15] =1, Indirect address[9:8] = '01', reads back the iCoef value, Indirect address[15] =1, Indirect address[9:8] = '10', reads back the qCoef value, Indirect address[15] =1, Indirect address[9:8] = '11', reads back the iCoef<3:0>, iShift<3:0>, qCoef<3:0>, qShift<3:0> value.
3. Wait 4 clock cycles between all of the above writes before performing the next write to the Ram address register.
4. Repeat steps 2-3.
5. Return RAM control back to the channel by disabling the  $\mu$ P hold mode.



TABLE 42. I AND Q CHANNEL COEFFICIENTS (15:0)

| TYPE: SINGLE CHANNEL INDIRECT, ADDRESS RANGE: 0x300-0x3ff (PAGE 3) |                    |   |
|--|--------------------|---|
| BIT  | FUNCTION           | DESCRIPTION   |
| 15:0   | Filter coefficient | 256 location RAM. Use this page when the I and Q coefficients are the same. |

## NOTES:

**Coefficients RAM Read/Write Procedure** (2's complement format only)

**Write** access to the Coefficient RAMs when I equal Q:

1. Enable the  $\mu$ P hold mode by setting bit 12 of the Main Control register 0x0c.
2. Load the RAM data to location 0x14 with the coefficient.
3. Load the RAM write address to location 0x15. A write strobe transfers the contents of the register at location 0x14 into the RAM location specified by the contents of the register at location 0x15. (Indirect address[15] =0, Indirect address[9:8]="11").
4. Wait 4 clock cycles before performing the next write to the RAM data register.
5. Repeat steps 2-4.
6. Return RAM control back to the channel by disabling the  $\mu$ P hold mode.

**Read** access to the Q Coefficient RAM:

1. Enable the  $\mu$ P hold mode by setting bit 12 of the Main Control register 0x0c.
2. Load the RAM read address to location 0x15. A read strobe transfers the contents of the RAM location specified by the contents of the register at location 0x15 onto the read bus. (Indirect address[15] =1, Indirect address[9:8]="11").
3. Wait 4 clock cycles before performing the next write to the RAM address register.
4. After all data has been loaded, return RAM control back to the channel by disabling the  $\mu$ P hold mode.

TABLE 43. TXENX CONTROL

| TYPE: SINGLE CHANNEL INDIRECT, ADDRESS RANGE: 0x400-0x407 (PAGE 4) |                     |  |
|--|---------------------|--|
| INDIRECT ADDRESS   | FUNCTION            | DESCRIPTION  |
| 0x400  | TXENX Cycle 0 Low   | TXENX cycle 0 low time count <15:0>.                   |
| 0x401  | TXENX Cycle 0 High  | TXENX cycle 0 high time count <15:0>.                  |
| 0x402  | TXENX Cycle 1 Low   | TXENX cycle 1 low time count <15:0>.                   |
| 0x403  | TXENX Cycle 1 High  | TXENX cycle 1 high time count <15:0>.                  |
| 0x404 - 0x406  | Reserved            | Not Used.  |
| 0x407  | TXENX Cycle Lengths | FSRMode<1:0>, cycle 1 length<4:0>, cycle 0 length<4:0> |

## NOTES:

FSRMode affects what is output on the channel FSRX pin, but only if TXENX control, control word 0x0c, bit 11 is set to one. The FSRMode<1:0> is defined as:

- 00 No change to FSRX output.
- 01 No change to FSRX output.
- 10 FSR = internal channel UPDX.
- 11 FSR = internal channel TXENX. TXENX SIB control (0x0c, bit 3) must be set when FSRMode 11 is utilized, otherwise a TXENX glitch will be observed on the rising edge of TXENX.

To start the TXENX cycle function following a reset, the user must provide a normal channel update via one of the 2 possible update mechanisms (software or hardware). An update also resets all of the TXENX counters and starts the device up in cycle 0 with TXENX high.

**Write** access to the TXENX cycle controls:

1. Enable the  $\mu$ P hold mode by setting bit 12 of the Main Control register 0x0c.
2. Load the data to location 0x14.
3. Load the indirect write address to location 0x15. A write strobe transfers the contents of the register at location 0x14 into the location specified by the contents of the register at location 0x15. (Indirect address[15] =0).
4. Assert the write strobe again to update the configuration register.
5. Wait 4 clock cycles before performing the next write to the data register.
6. Repeat steps 2-5.
7. Return control back to the channel by disabling the  $\mu$ P hold mode.

**Read** access to the TXENX cycle controls:

Care should be utilized to only read registers back immediately after writing since loading indirect addr 0x15 with 040X causes 0x040X to get loaded with indirect register 0x14's contents.

1. Enable the  $\mu$ P hold mode by setting bit 12 of the Main Control register 0x0c.
2. Load the read address to location 0x15. A read strobe transfers the contents of the RAM location specified by the contents of the register at location 0x15 onto the read bus. (Indirect address[15] =1).
3. Wait 4 clock cycles before performing the next write to the address register.
4. Return control back to the channel by disabling the  $\mu$ P hold mode.

## Miscellaneous Control Registers

TABLE 44. TEST CONTROL (15:0)





| TYPE: SINGLE CHANNEL DIRECT, ADDRESS: 0x17 |   |   |
|--|---|---|
| BIT  | FUNCTION                                  | DESCRIPTION   |
| 15   | FSR $\bar{X}$ and SCLK $\bar{X}$ shut off | FSR $\bar{X}$ and SCLK $\bar{X}$ , from default, turn off synchronously to CLK. Set to 1 to enable FSR $\bar{X}$ and SCLK $\bar{X}$ signals to be shut off on the boundary of SCLK $\bar{X}$ .  |
| 14:13                                      | Serial Transfer Delay                     | Set both these bits to allow back-to-back serial transfers by programming the delay for the internal serial data. Setting 0x17, bit 14 delays the internal serial data bit by the serial clock pipeline latency through the input pad. Setting 0x17, bit 13 delays and aligns the internal sample_clk_32x to match the FIFO timing so no dead cycles occur. |
| 12   | Filter Coefficient mode                   | Set to 1 to enable 24-bit floating point mode. Default (reset) mode is 16-bit 2's complement.<br>0=2's complement.<br>1=24-bit floating point.  |
| 11   | Reserved                                  | Not used.   |
| 10   | Pad hold adjustment                       | Hold select for serial data.  |
| 9  | Pad Hold Adjustment                       | Hold select for $\overline{CS}$ and A[6:0].   |
| 8  | Pad Hold Adjustment                       | Hold select for d in of IIN[19:0] and QIN[19:0].  |
| 7  | PN Gen Enable                             | Turn on PN Generator.   |
| 6  | PN Gen Rate                               | When asserted high forces PN gen to run at the clock rate. When asserted low forces PN gen to run at the symbol rate  |
| 5  | Reserved                                  | Not used  |
| 4  | Straight Thru                             | Pass FIFO output directly to the int filter, (bypasses the shaping filter and FM generator)   |
| 3  | Select PN Generator                       | Select PN generator as the source for FIFO data in  |
| 2  | Force Edge                                | Bypass sample NCO control and move data in the shaping and interpolation filter every clock   |
| 1  | Force FIFO En                             | Bypass sample NCO control and move data from the FIFO every clock.  |
| 0  | Force Carrier ROM                         | Force output of SIN/COS ROM, sin=cos= 0x1FFFF.  |

NOTE: Test controls (10:7) are valid for Channel 0 only. They are not used and cleared to zero in channels 1-3.

TABLE 45. DEVICE CONTROL

| TYPE: DEVICE CONTROL DIRECT, ADDRESS: 0x78 |   |   |
|--|---|---|
| BIT  | FUNCTION                                | DESCRIPTION   |
| 15   | Immediate Update (Top Cont. Reg Update) | Allows $\mu$ P writes to bypass the update mask and load the selected top configuration slave register immediately from the master, (requires 4 CLK synchronization). This update only affects Top Output Routing Control, 0x79.  |
| 14   | BIST Mode Control                       | Built in Self Test (BIST) mode control pin. Set to 1 to enter the BIST test mode.<br>0=BIST Disabled (default).<br>1=BIST mode enabled.   |
| 14:11                                      | Reserved                                | Not used  |
| 10   | Output 2X Select                        | Used to set the muxed I/Q at 2X rate output mode to output data at twice the sample rate. When enabled the clock is used to select I data when the clock is high and Q data when the clock is low. This bit is only used in conjunction with Output mode (1:0) = 01, selecting Four channel I data out at 104MHz, (4 x 20) when disabled, and Muxed I/Q at the 2X rate when enabled.<br>0 = Disabled<br>1 = Enabled |
| 9:8  | Output Mode (1:0)                       | Configures output mode of device.a<br>00 = I and Q cascade in, (2 x 20), I and Q cascade out, (2 x 20)<br>01 = Four channel I data out at 104MHz, (4 x 20)<br>10 = Four channel Q data out at 104MHz, (4 x 20)<br>11 = Four channel muxed I/Q data out at 52MHz, (4 x 20)   |

TABLE 45. DEVICE CONTROL (Continued)

| TYPE: DEVICE CONTROL DIRECT, ADDRESS: 0x78 |                      |   |
|--|----------------------|---|
| BIT  | FUNCTION             | DESCRIPTION   |
| 7  | Sync Out Polarity    | Sync out polarity<br>0 = defines a sync assertion as a transition from a logic low to a logic high.<br>1 = defines a sync assertion as a transition from a logic high to a logic low.<br><br>0 =  1 =                                      |
| 6  | Output Enable        | Enables data out of the device. Zeroes the data when low.   |
| 5  | I Strobe Enable      | Indicates when I data is output in the muxed I/Q mode.  |
| 4  | I Strobe Polarity    | I strobe polarity.<br>0 = defines a sync assertion as a transition from a logic low to a logic high. (I out when low)<br>1 = defines a sync assertion as a transition from a logic high to a logic low. (I out when high)<br><br>0 =  1 =  |
| 3  | Cascade Input Enable | Enables I and Q cascade data into the device. Zeroes the input buses when low. Set to zero when using any mode other than Cascade.  |
| 2:1  | Cascade Delay (1:0)  | Delays the 4 Ch sum to align with the cascade input summer. A cascade of 4 devices is supported.<br>00 = No Delay for master.<br>01 = Delay for first slave.<br>10 = Delay for second slave.<br>11 = Delay for last slave.  |
| 0  | Broadcast            | Enables all four channels to receive current $\mu$ P write access.  |

NOTES:

- 37. There is also a complex output mode available for 4-ch summers 1 and 3 when the cascade feature is not required. This is accomplished by setting the output mode to 0x01 in the top control register and selecting the complex output mode in the main control register of channel 0 or channel 2. This mode allows I and Q data to be clocked out in parallel at the full rate. Refer to the Main Control register for further detail.
- 38. The cascade input of the first device in a cascade chain must be disabled.

TABLE 46. DEVICE OUTPUT ROUTING

| TYPE: DEVICE CONTROL DIRECT, ADDRESS: 0x79 |                   |   | OUTPUT MODE |           |           |           | REAL, IMAG, or MUXED |
|--|-------------------|---|-------------|-----------|-----------|-----------|----------------------|
| BIT  | FUNCTION          | DESCRIPTION                                 | CASCADE     | COMPLEX 1 | COMPLEX 2 | COMPLEX 3 |                      |
| 15   | Channel 3 Routing | Routes channel 3 output to output summer 4. |             | X         |           |           | X                    |
| 14   | Channel 3 Routing | Routes channel 3 output to output summer 3. |             | X         | X         | X         | X                    |
| 13   | Channel 3 Routing | Routes channel 3 output to output summer 2. |             |           | X         |           | X                    |
| 12   | Channel 3 Routing | Routes channel 3 output to output summer 1. | X           | X         | X         | X         | X                    |
| 11   | Channel 2 Routing | Routes channel 2 output to output summer 4. |             | X         |           |           | X                    |
| 10   | Channel 2 Routing | Routes channel 2 output to output summer 3. |             | X         | X         | X         | X                    |
| 9  | Channel 2 Routing | Routes channel 2 output to output summer 2. |             |           | X         |           | X                    |
| 8  | Channel 2 Routing | Routes channel 2 output to output summer 1. | X           | X         | X         | X         | X                    |
| 7  | Channel 1 Routing | Routes channel 1 output to output summer 4. |             | X         |           |           | X                    |
| 6  | Channel 1 Routing | Routes channel 1 output to output summer 3. |             | X         | X         | X         | X                    |
| 5  | Channel 1 Routing | Routes channel 1 output to output summer 2. |             |           | X         |           | X                    |
| 4  | Channel 1 Routing | Routes channel 1 output to output summer 1. | X           | X         | X         | X         | X                    |
| 3  | Channel 0 Routing | Routes channel 0 output to output summer 4. |             | X         |           |           | X                    |

TABLE 46. DEVICE OUTPUT ROUTING (Continued)

| TYPE: DEVICE CONTROL DIRECT, ADDRESS: 0x79 |                   |  | OUTPUT MODE |           |           |           | REAL, IMAG, or MUXED |
|--|-------------------|--|-------------|-----------|-----------|-----------|----------------------|
| BIT  | FUNCTION          | DESCRIPTION                                | CASCADE     | COMPLEX 1 | COMPLEX 2 | COMPLEX 3 |                      |
| 2  | Channel 0 Routing | Routes channel 0 output to output summer 3 |             | X         | X         | X         | X                    |
| 1  | Channel 0 routing | Routes channel 0 output to output summer 2 |             |           | X         |           | X                    |
| 0  | Channel 0 routing | Routes channel 0 output to output summer 1 | X           | X         | X         | X         | X                    |

NOTE:

39. X = Channel routed to output and can be enabled. Enable = 1, disable = 0.

TABLE 47. DEVICE OUTPUT ROUTING CONTROL SUMMARY

| FUNCTION          | BIT   | CH ASSIGNMENT TO OUTPUT SUMMERS         |
|-------------------|-------|---|
| Channel 3 Routing | 15:12 | Summer 4, Summer 3, Summer 2, Summer 1. |
| Channel 2 Routing | 11:8  | Summer 4, Summer 3, Summer 2, Summer 1. |
| Channel 1 Routing | 7:4   | Summer 4, Summer 3, Summer 2, Summer 1. |
| Channel 0 Routing | 3:0   | Summer 4, Summer 3, Summer 2, Summer 1. |

TABLE 48. OUTPUT MODES

| OUTPUT MODE | TRITST | OUTEN (1:0) | IIN (19:10) | IIN (9:0) | QIN (19:10) | QIN (9:0) | IOUT (19:10) | IOUT (9:0) | QOUT (19:10) | QOUT (9:0) |
|-------------|--------|-------------|-------------|-----------|-------------|-----------|--------------|------------|--------------|------------|
| 00          | 0      | 00          | HI-Z        | HI-Z      | HI-Z        | HI-Z      | Enabled      | Enabled    | Enabled      | Enabled    |
| 00          | 0      | 01          | HI-Z        | HI-Z      | HI-Z        | HI-Z      | Enabled      | Enabled    | HI-Z         | HI-Z       |
| 00          | 0      | 10          | HI-Z        | HI-Z      | HI-Z        | HI-Z      | HI-Z         | HI-Z       | Enabled      | Enabled    |
| 00          | 0      | 11          | HI-Z        | HI-Z      | HI-Z        | HI-Z      | HI-Z         | HI-Z       | HI-Z         | HI-Z       |
| 00          | 1      | 00          | HI-Z        | HI-Z      | HI-Z        | HI-Z      | HI-Z         | HI-Z       | HI-Z         | Enabled    |
| 00          | 1      | 01          | HI-Z        | HI-Z      | HI-Z        | HI-Z      | HI-Z         | HI-Z       | Enabled      | HI-Z       |
| 00          | 1      | 10          | HI-Z        | HI-Z      | HI-Z        | HI-Z      | HI-Z         | Enabled    | HI-Z         | HI-Z       |
| 00          | 1      | 11          | HI-Z        | HI-Z      | HI-Z        | HI-Z      | Enabled      | HI-Z       | HI-Z         | HI-Z       |
| 01,10,11    | 0      | 00          | Enabled     | Enabled   | Enabled     | Enabled   | Enabled      | Enabled    | Enabled      | Enabled    |
| 01,10,11    | 0      | 01          | Enabled     | Enabled   | HI-Z        | HI-Z      | Enabled      | Enabled    | HI-Z         | HI-Z       |
| 01,10,11    | 0      | 10          | HI-Z        | HI-Z      | Enabled     | Enabled   | HI-Z         | HI-Z       | Enabled      | Enabled    |
| 01,10,11    | 0      | 11          | HI-Z        | HI-Z      | HI-Z        | HI-Z      | HI-Z         | HI-Z       | HI-Z         | HI-Z       |
| 01,10,11    | 1      | 00          | HI-Z        | HI-Z      | HI-Z        | Enabled   | HI-Z         | HI-Z       | HI-Z         | Enabled    |
| 01,10,11    | 1      | 01          | HI-Z        | HI-Z      | Enabled     | HI-Z      | HI-Z         | HI-Z       | Enabled      | HI-Z       |
| 01,10,11    | 1      | 10          | HI-Z        | Enabled   | HI-Z        | HI-Z      | HI-Z         | Enabled    | HI-Z         | HI-Z       |
| 01,10,11    | 1      | 11          | Enabled     | HI-Z      | HI-Z        | HI-Z      | Enabled      | HI-Z       | HI-Z         | HI-Z       |

TABLE 49. COEFFICIENT ADDRESSES

|      | DS[n] | DS[n-1] | DS[n-2] | DS[n-3] | DS[n-4] | ... | DS[n-12] | DS[n-13] | DS[n-14] | DS[n-15] |
|------|-------|---------|---------|---------|---------|-----|----------|----------|----------|----------|
| IP0  | 0     | 16      | 32      | 48      | 64      | ... | 192      | 208      | 224      | 240      |
| IP1  | 1     | 17      | 33      | 49      | 65      | ... | 193      | 209      | 225      | 241      |
| IP2  | 2     | 18      | 34      | 50      | 66      | ... | 194      | 210      | 226      | 242      |
| IP3  | 3     | 19      | 35      | 51      | 67      | ... | 195      | 211      | 227      | 243      |
| IP4  | 4     | 20      | 36      | 52      | 68      | ... | 196      | 212      | 228      | 244      |
| IP5  | 5     | 21      | 37      | 53      | 69      | ... | 197      | 213      | 229      | 245      |
| IP6  | 6     | 22      | 38      | 54      | 70      | ... | 198      | 214      | 230      | 246      |
| IP7  | 7     | 23      | 39      | 55      | 71      | ... | 199      | 215      | 231      | 247      |
| IP8  | 8     | 24      | 40      | 56      | 72      | ... | 200      | 216      | 232      | 248      |
| IP9  | 9     | 25      | 41      | 57      | 73      | ... | 201      | 217      | 233      | 249      |
| IP10 | 10    | 26      | 42      | 58      | 74      | ... | 202      | 218      | 234      | 250      |
| IP11 | 11    | 27      | 43      | 59      | 75      | ... | 203      | 219      | 235      | 251      |
| IP12 | 12    | 28      | 44      | 60      | 76      | ... | 204      | 220      | 236      | 252      |
| IP13 | 13    | 29      | 45      | 61      | 77      | ... | 205      | 221      | 237      | 253      |
| IP14 | 14    | 30      | 46      | 62      | 78      | ... | 206      | 222      | 238      | 254      |
| IP15 | 15    | 31      | 47      | 63      | 79      | ... | 207      | 223      | 239      | 255      |

TABLE 50. REVISION HISTORY

| REVISION NUMBER | REVISION DATE     | REVISION DESCRIPTION  |
|-----------------|-------------------|---|
| 6004.2          | February 20, 2003 | <ul style="list-style-type: none"> <li>- Added a NOTE in the Pinout Diagram</li> <li>- See the note for CS pin description and Microprocessor Interface section</li> <li>- Figure 11, "Re-sampling NCO Block Diagram" -- corrected bit-weights</li> <li>- Table 8, "Input/Output Modes" -- corrected</li> <li>- Corrected the NOTE 3 in "Absolute Maximum Ratings" Table</li> <li>- Table 49, "Coefficient Addresses" -- corrected</li> <li>- Appendix A added</li> </ul> |

## Appendix A -- Errata Sheet

### Microprocessor Interface Issue

A Chip Select ( $\overline{CS}$ ) operational issue has been identified and isolated to the design of the pad input circuitry in the write ( $\overline{WR}$ ) input cell. Under certain conditions, the combinational logic contained in the pads allows an internal chip rising edge write ( $\overline{WR\_To\_Core}$ ) signal to occur when the external  $\overline{WR}$  pin is high and the  $\overline{CS}$  pin is transitioned from the inactive high state to the active low state. The combinational logic contained in the pads is functionally shown in Figure 29.

If after a completed write cycle to the chip, the  $\overline{WR}$  is again asserted low while  $\overline{CS}$  is inactive high, as would happen if a write to another device on the bus occurs, the state of the control logic in the chip is changed such that the next time  $\overline{CS}$  is asserted low and  $\overline{WR}$  is inactive high, as would happen at the start of a chip read cycle, an internal  $\overline{WR\_To\_Core}$  strobe will be generated and the chip register corresponding to the state of the address bus at the time of the falling edge of  $\overline{CS}$  will be inadvertently loaded with the data present on the data bus P<15:0>.

#### Work Arounds

The recommended work around for the device is to place the status register address (0x016) or any unused address on the A<6:0> address bus prior to enabling the device with the  $\overline{CS}$  line. The excess write will then either clear the device's status register or perform a "dummy" write to an unused address space as the chip is enabled. Care should be utilized when enabling the  $\overline{CS}$  such that the dummy address remains on the bus until any  $\overline{CS}$  decoding bounces are complete.

Alternatively, if system considerations allow, on read operations the  $\overline{WR}$  could be placed in the active low state prior to  $\overline{CS}$  being asserted active low per Figure 30. This would be enveloping the  $\overline{CS}$  signal with the  $\overline{WR}$  signal, thus preventing the extra write from occurring on the falling edge of  $\overline{CS}$ . Similarly during a write cycle, the  $\overline{WR}$  could be placed in the active low state prior to  $\overline{CS}$  being asserted active low per Figure 31, with the write occurring on the rising edge of  $\overline{WR}$ .

These work arounds will prevent the occurrence of an uncontrolled write when  $\overline{CS}$  is asserted low and prevent the alteration of operational register contents.

#### Future Revisions

Hardware solutions to correct this undesired write have been reviewed, and the design may be modified to prevent this occurrence in future versions of the devices. Any such changes will be backwards compatible to the existing device, such that the recommended work-arounds will not affect the operation of the device in existing designs.

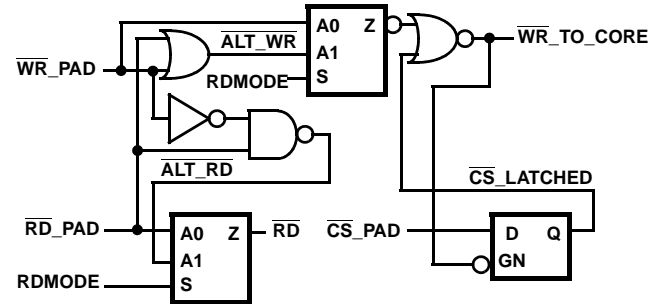

FIGURE 29.  $\overline{CS}$  SIMPLIFIED SCHEMATIC

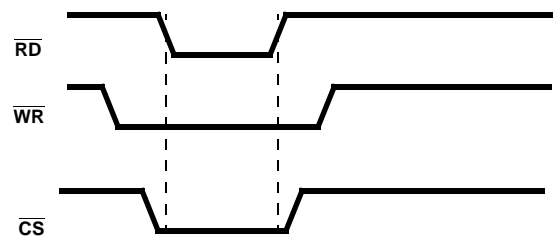

FIGURE 30. READ CYCLE

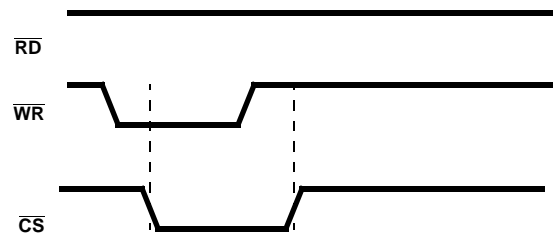

FIGURE 31. WRITE CYCLE

### JTAG Testing

The bi-directional type pins cannot be used as inputs in EXTEST mode, however they do work in SAMPLE mode.

#### Work Arounds

The test vectors should be written such that the bi-directional pins are used only as outputs, with the device on the other end of the line used as the input. Alternatively, the test vectors can be written such that SAMPLE mode is used when treating the bi-directional pins as inputs.

Plastic Ball Grid Array Packages (BGA)

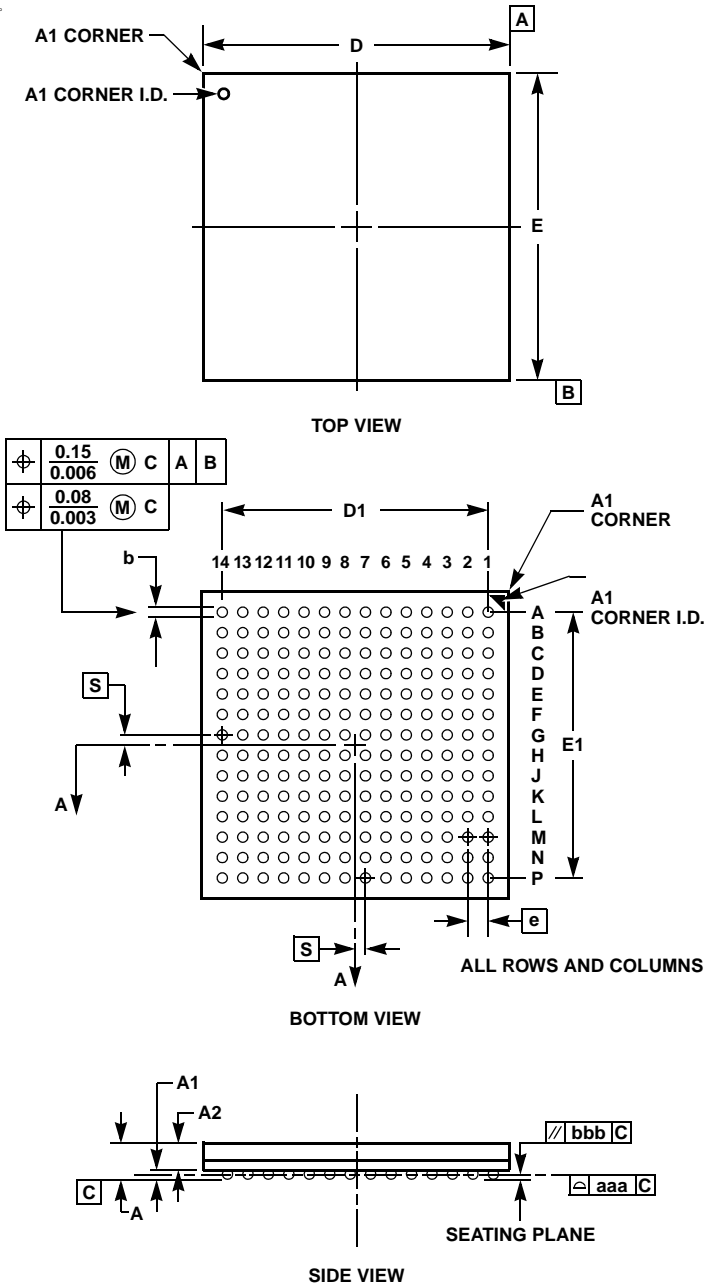

**V196.15x15**  
196 BALL PLASTIC BALL GRID ARRAY PACKAGE

| SYMBOL | INCHES    |       | MILLIMETERS |       | NOTES |
|--------|-----------|-------|-------------|-------|-------|
|        | MIN       | MAX   | MIN         | MAX   |       |
| A      | -         | 0.059 | -           | 1.50  | -     |
| A1     | 0.012     | 0.016 | 0.31        | 0.41  | -     |
| A2     | 0.037     | 0.044 | 0.93        | 1.11  | -     |
| b      | 0.016     | 0.020 | 0.41        | 0.51  | 7     |
| D/E    | 0.587     | 0.595 | 14.90       | 15.10 | -     |
| D1/E1  | 0.508     | 0.516 | 12.90       | 13.10 | -     |
| N      | 196       |       | 196         |       | -     |
| e      | 0.039 BSC |       | 1.0 BSC     |       | -     |
| MD/ME  | 14 x 14   |       | 14 x 14     |       | 3     |
| bbb    | 0.004     |       | 0.10        |       | -     |
| aaa    | 0.005     |       | 0.12        |       | -     |

Rev. 1 12/00

NOTES:

- Controlling dimension: MILLIMETER. Converted inch dimensions are not necessarily exact.
- Dimensioning and tolerancing conform to ASME Y14.5M-1994.
- "MD" and "ME" are the maximum ball matrix size for the "D" and "E" dimensions, respectively.
- "N" is the maximum number of balls for the specific array size.
- Primary datum C and seating plane are defined by the spherical crowns of the contact balls.
- Dimension "A" includes standoff height "A1", package body thickness and lid or cap height "A2".
- Dimension "b" is measured at the maximum ball diameter, parallel to the primary datum C.
- Pin "A1" is marked on the top and bottom sides adjacent to A1.
- "S" is measured with respect to datum's A and B and defines the position of the solder balls nearest to package centerlines. When there is an even number of balls in the outer row the value is "S" = e/2.

All Intersil U.S. products are manufactured, assembled and tested utilizing ISO9000 quality systems. Intersil Corporation's quality certifications can be viewed at [www.intersil.com/design/quality](http://www.intersil.com/design/quality)

*Intersil products are sold by description only. Intersil Corporation reserves the right to make changes in circuit design, software and/or specifications at any time without notice. Accordingly, the reader is cautioned to verify that data sheets are current before placing orders. Information furnished by Intersil is believed to be accurate and reliable. However, no responsibility is assumed by Intersil or its subsidiaries for its use; nor for any infringements of patents or other rights of third parties which may result from its use. No license is granted by implication or otherwise under any patent or patent rights of Intersil or its subsidiaries.*

For information regarding Intersil Corporation and its products, see [www.intersil.com](http://www.intersil.com)