

APT801R2CN	800V	7.0A	1.20Ω
APT751R2CN	750V	7.0A	1.20Ω
APT801R4CN	800V	6.5A	1.40Ω
APT751R4CN	750V	6.5A	1.40Ω

## POWER MOS IV™

### N - CHANNEL ENHANCEMENT MODE HIGH VOLTAGE POWER MOSFETS

#### MAXIMUM RATINGS

All Ratings:  $T_C = 25^\circ\text{C}$  unless otherwise specified.

Symbol	Parameter	APT 751R2CN	APT 801R2CN	APT 751R4CN	APT 801R4CN	UNIT
$V_{DSS}$	Drain-Source Voltage	750	800	750	800	Volts
$I_D$	Continuous Drain Current @ $T_C = 25^\circ\text{C}$	7.0		6.5		Amps
$I_{DM}$	Pulsed Drain Current <sup>①</sup>	28		26		
$V_{GS}$	Gate-Source Voltage	±30				Volts
$P_D$	Total Power Dissipation @ $T_C = 25^\circ\text{C}$	150				Watts
	Linear Derating Factor	1.2				W/°C
$T_J, T_{STG}$	Operating and Storage Junction Temperature Range	-55 to 150				°C
$T_L$	Lead Temperature: 0.063" from Case for 10 Sec.	300				

#### STATIC ELECTRICAL CHARACTERISTICS

Symbol	Characteristic / Test Conditions / Part Number	MIN	TYP	MAX	UNIT
$BV_{DSS}$	Drain-Source Breakdown Voltage ( $V_{GS} = 0V, I_D = 250 \mu\text{A}$ )	APT801R2CN / APT801R4CN	800		Volts
		APT751R2CN / APT751R4CN	750		
$I_{D(ON)}$	On State Drain Current <sup>②</sup> ( $V_{DS} > I_{D(ON)} \times R_{DS(ON)}$ Max, $V_{GS} = 10V$ )	APT801R2CN / APT751R2CN	7.0		Amps
		APT801R4CN / APT751R4CN	6.5		
$R_{DS(ON)}$	Drain-Source On-State Resistance <sup>②</sup> ( $V_{GS} = 10V, 0.5 I_D$ [Cont.])	APT801R2CN / APT751R2CN		1.20	Ohms
		APT801R4CN / APT751R4CN		1.40	
$I_{DSS}$	Zero Gate Voltage Drain Current ( $V_{DS} = V_{DSS}, V_{GS} = 0V$ )			250	$\mu\text{A}$
	Zero Gate Voltage Drain Current ( $V_{DS} = 0.8 V_{DSS}, V_{GS} = 0V, T_C = 125^\circ\text{C}$ )			1000	
$I_{GSS}$	Gate-Source Leakage Current ( $V_{GS} = \pm 30V, V_{DS} = 0V$ )			±100	nA
$V_{GS(TH)}$	Gate Threshold Voltage ( $V_{DS} = V_{GS}, I_D = 1.0\text{mA}$ )	2		4	Volts

#### THERMAL CHARACTERISTICS

Symbol	Characteristic	MIN	TYP	MAX	UNIT
$R_{\theta JC}$	Junction to Case			0.80	°C/W
$R_{\theta JA}$	Junction to Ambient			50	

405 S.W. COLUMBIA STREET  
BEND, OREGON 97702-1035  
U.S.A.

PHONE ... (503) 382-8028

FAX ..... (503) 388-0364

**DYNAMIC CHARACTERISTICS**

Symbol	Characteristic	Test Conditions	MIN	TYP	MAX	UNIT
$C_{DC}$	Drain-to-Case Capacitance	$f = 1 \text{ MHz}$		15	22	pF
$C_{iss}$	Input Capacitance	$V_{GS} = 0V$ $V_{DS} = 25V$ $f = 1 \text{ MHz}$		1500	1800	
$C_{oss}$	Output Capacitance			235	330	
$C_{rss}$	Reverse Transfer Capacitance			85	127	
$Q_g$	Total Gate Charge ③	$V_{GS} = 10V$ $V_{DD} = 0.5 V_{DSS}$ $I_D = I_D [\text{Cont.}] @ 25^\circ C$		68	105	nC
$Q_{gs}$	Gate-Source Charge			7.6	11	
$Q_{gd}$	Gate-Drain ("Miller") Charge			33	49	
$t_{d(on)}$	Turn-on Delay Time	$V_{GS} = 15V$ $V_{DD} = 0.5 V_{DSS}$ $I_D = I_D [\text{Cont.}] @ 25^\circ C$ $R_G = 1.8\Omega$		12	24	ns
$t_r$	Rise Time			15	30	
$t_{d(off)}$	Turn-off Delay Time			52	78	
$t_f$	Fall Time			18	36	

**SOURCE-DRAIN DIODE RATINGS AND CHARACTERISTICS**

Symbol	Characteristic / Test Conditions	MIN	TYP	MAX	UNIT
$I_S$	Continuous Source Current (Body Diode)	APT801R2CN / APT751R2CN		7.0	Amps
		APT801R4CN / APT751R4CN		6.5	
$I_{SM}$	Pulsed Source Current ① (Body Diode)	APT801R2CN / APT751R2CN		28	
		APT801R4CN / APT751R4CN		26	
$V_{SD}$	Diode Forward Voltage ② ( $V_{GS} = 0V, I_S = -I_D [\text{Cont.}]$ )			1.3	Volts
$t_{rr}$	Reverse Recovery Time ( $I_S = -I_D [\text{Cont.}], di_S/dt = 100A/\mu s$ )	240	480	960	ns
$Q_{rr}$	Reverse Recovery Charge ( $I_S = -I_D [\text{Cont.}], di_S/dt = 100A/\mu s$ )	1.7	3.4	7.0	$\mu C$

**SAFE OPERATING AREA CHARACTERISTICS**

Symbol	Characteristic	Test Conditions	MIN	TYP	MAX	UNIT
SOA1	Safe Operating Area	$V_{DS} = 0.4 V_{DSS}, I_{DS} = P_D / 0.4 V_{DSS}, t = 1 \text{ Sec.}$	150			Watts
SOA2	Safe Operating Area	$I_{DS} = I_D [\text{Cont.}], V_{DS} = P_D / I_D [\text{Cont.}], t = 1 \text{ Sec.}$	150			
$I_{LM}$	Inductive Current Clamped	APT801R2CN / APT751R2CN	28			Amps
		APT801R4CN / APT751R4CN	26			

① Repetitive Rating: Pulse width limited by maximum junction temperature. See Transient Thermal Impedance Curve. (Fig.1)

② Pulse Test: Pulse width < 380  $\mu s$ , Duty Cycle < 2%

③ See MIL-STD-750 Method 3471

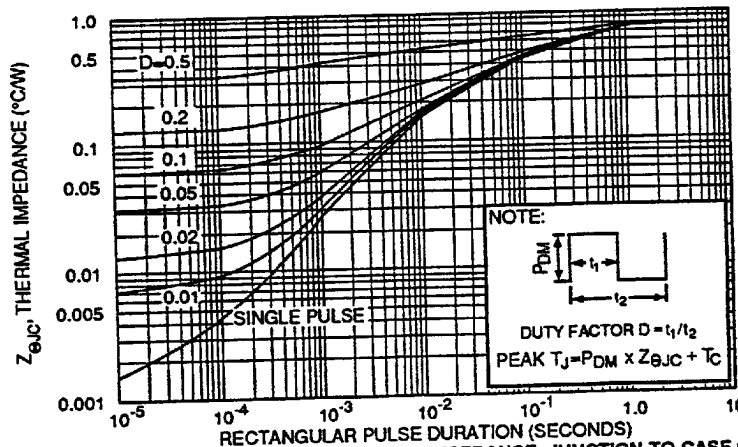

FIGURE 1, MAXIMUM EFFECTIVE TRANSIENT THERMAL IMPEDANCE, JUNCTION-TO-CASE vs PULSE DURATION

APT801R2/751R2/801R4/751R4CN

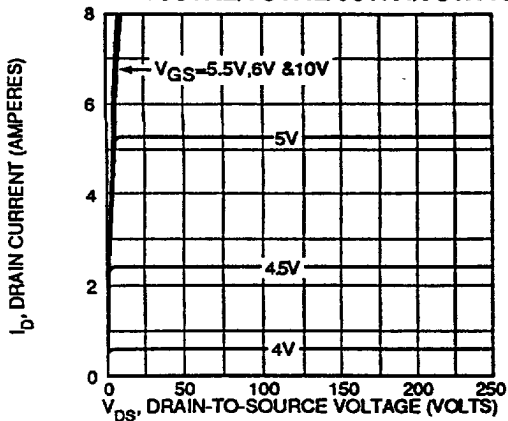

FIGURE 2, TYPICAL OUTPUT CHARACTERISTICS

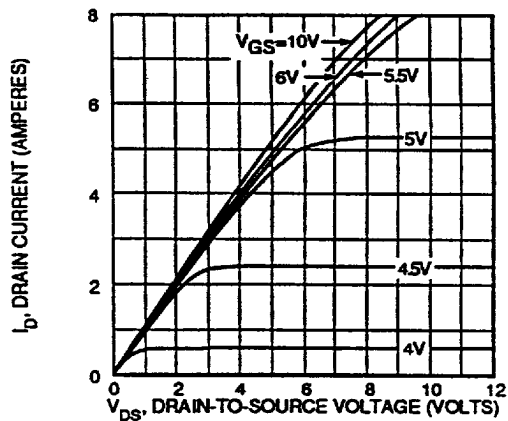

FIGURE 3, TYPICAL OUTPUT CHARACTERISTICS

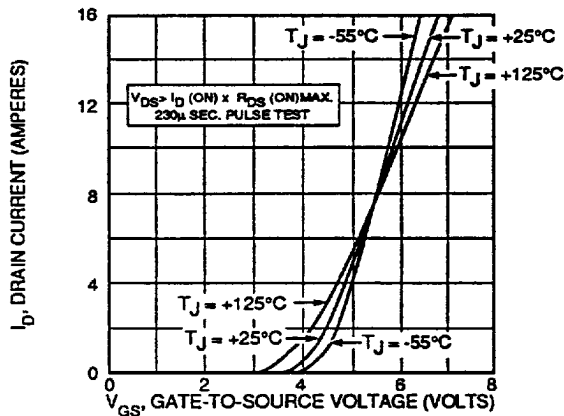

FIGURE 4, TYPICAL TRANSFER CHARACTERISTICS

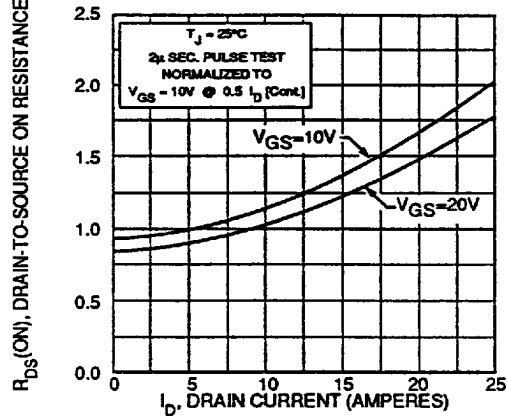

FIGURE 5,  $R_{DS(ON)}$  vs DRAIN CURRENT

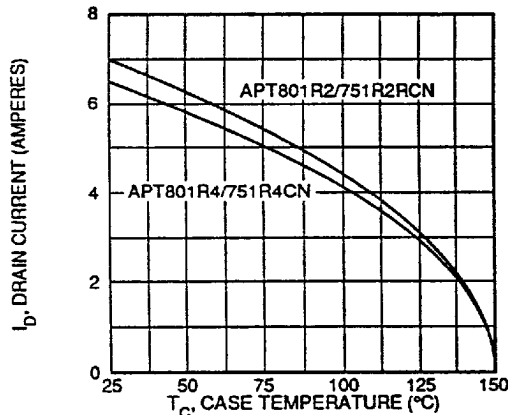

FIGURE 6, MAXIMUM DRAIN CURRENT vs CASE TEMPERATURE

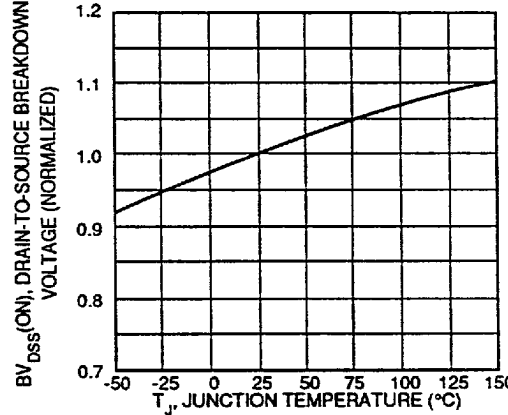

FIGURE 7, BREAKDOWN VOLTAGE vs TEMPERATURE

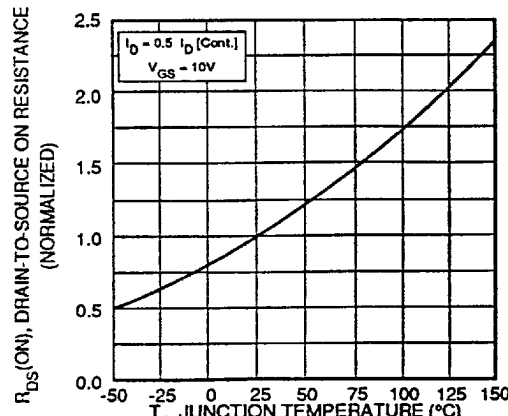

FIGURE 8, ON-RESISTANCE vs. TEMPERATURE

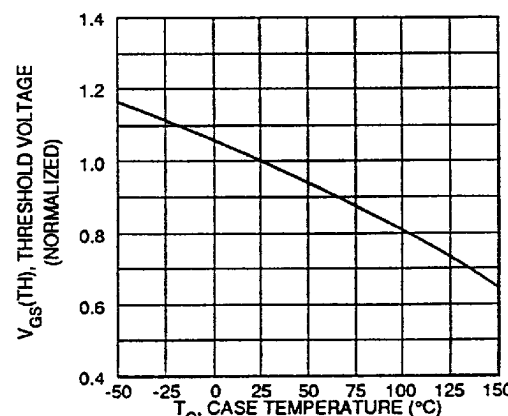

FIGURE 9, THRESHOLD VOLTAGE vs TEMPERATURE

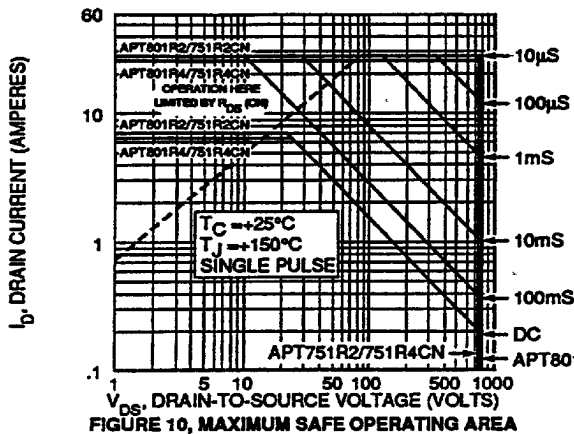

FIGURE 10, MAXIMUM SAFE OPERATING AREA

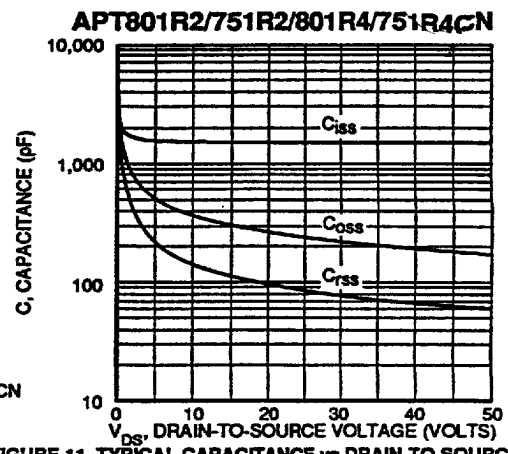

FIGURE 11, TYPICAL CAPACITANCE vs DRAIN-TO-SOURCE VOLTAGE

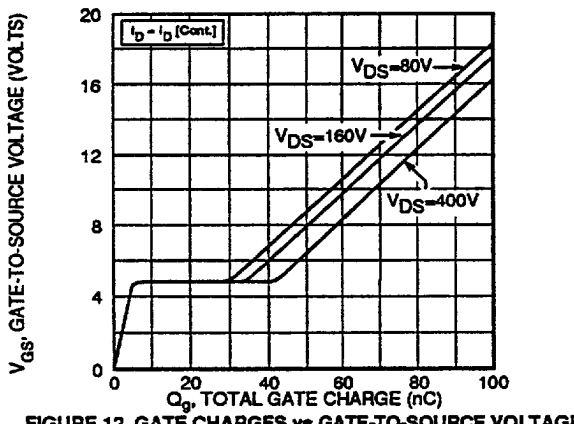

FIGURE 12, GATE CHARGES vs GATE-TO-SOURCE VOLTAGE

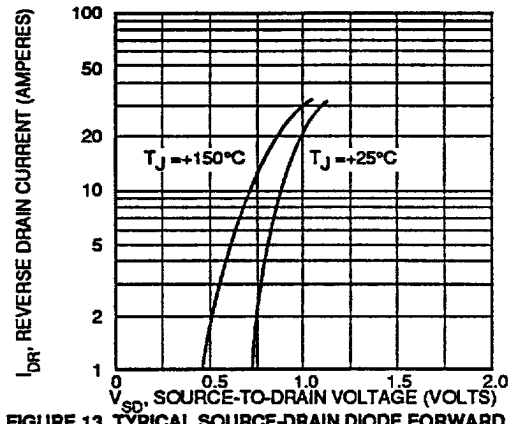
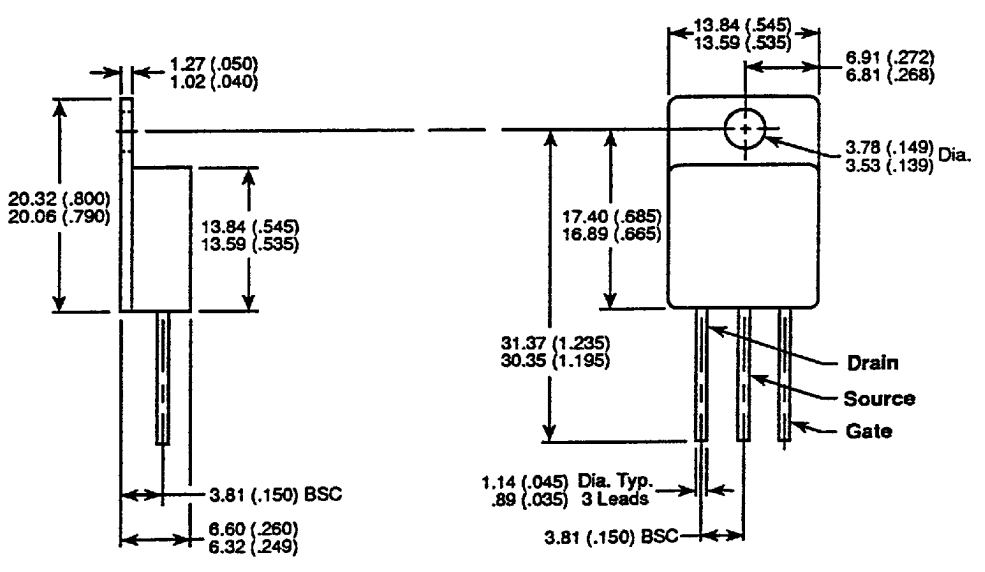

FIGURE 13, TYPICAL SOURCE-DRAIN DIODE FORWARD VOLTAGE

TO-254AA Package Outline



Dimensions in Millimeters and (Inches)

050-8015  
Rev A

4