

Preliminary Information

AMD Athlon™

Processor Data Sheet

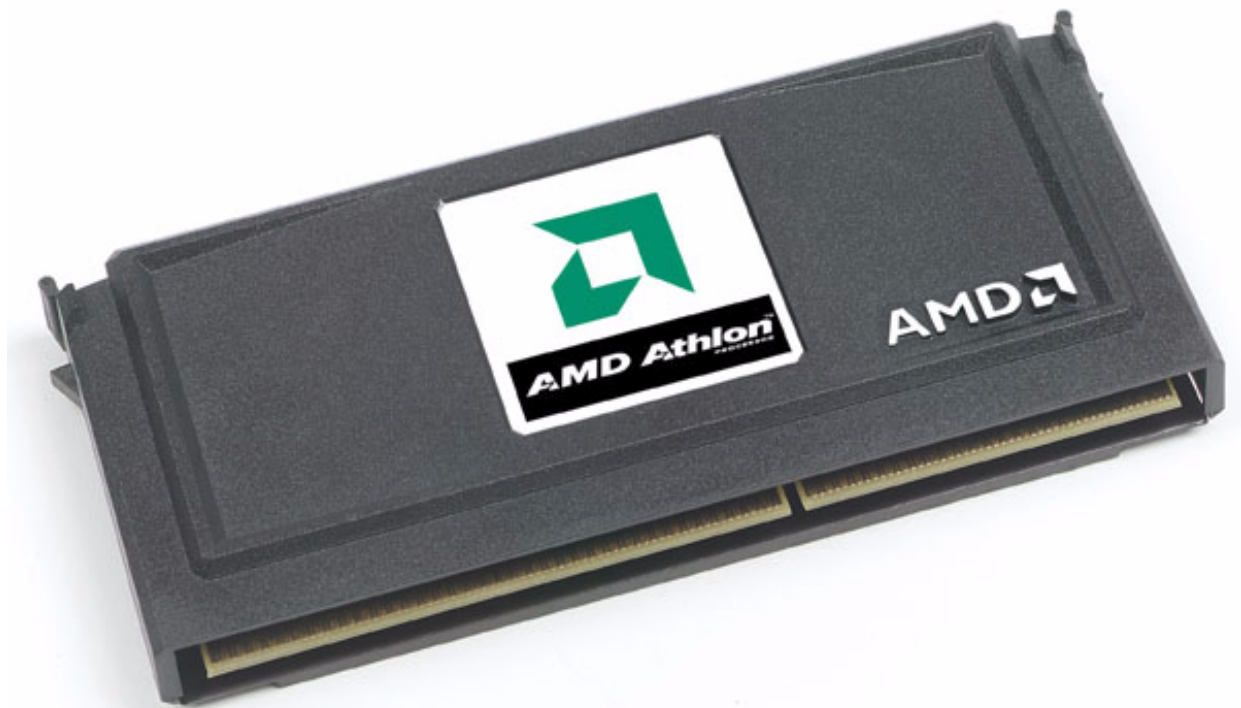

Publication # 21016 Rev: G
Issue Date: December 1999

AMD 

Preliminary Information

© 1999 **Advanced Micro Devices, Inc.** All rights reserved.

The contents of this document are provided in connection with Advanced Micro Devices, Inc. ("AMD") products. AMD makes no representations or warranties with respect to the accuracy or completeness of the contents of this publication and reserves the right to make changes to specifications and product descriptions at any time without notice. No license, whether express, implied, arising by estoppel or otherwise, to any intellectual property rights is granted by this publication. Except as set forth in AMD's Standard Terms and Conditions of Sale, AMD assumes no liability whatsoever, and disclaims any express or implied warranty, relating to its products including, but not limited to, the implied warranty of merchantability, fitness for a particular purpose, or infringement of any intellectual property right.

AMD's products are not designed, intended, authorized or warranted for use as components in systems intended for surgical implant into the body, or in other applications intended to support or sustain life, or in any other application in which the failure of AMD's product could create a situation where personal injury, death, or severe property or environmental damage may occur. AMD reserves the right to discontinue or make changes to its products at any time without notice.

Trademarks

AMD, the AMD logo, AMD Athlon, and combinations thereof, 3DNow!, AMD-751, and AMD-756 are trademarks of Advanced Micro Devices, Inc.

MMX is a trademark of Intel Corporation.

Alpha is a trademark of Digital Equipment Corporation.

Other product names used in this publication are for identification purposes only and may be trademarks of their respective companies.

Contents

Revision History	xi
About This Data Sheet	1

Part One

AMD Athlon™ Processor Family	3
1 Overview	1
1.1 AMD Athlon™ Processor Microarchitecture Summary	2
2 Interface Signals	5
2.1 Overview	5
2.2 Signaling Technology	5
2.3 AMD Athlon™ System Bus Signals	5
3 Logic Symbol Diagram	9
4 Power Management	11
4.1 Power Management States	11
Full-On	12
Halt State	12
Stop Grant and Sleep States	12
Probe State	13
4.2 Connection and Disconnection Protocol	13
Connection Protocol	14
Connection State Machines	18
5 Thermal Design	21
6 Electrical Data	23
6.1 The AMD Athlon™ System Bus	23
6.2 Signal Groupings	23
Clock Forwarding	24
6.3 Voltage Identification	25
6.4 Frequency Identification	26
6.5 Decoupling	26
6.6 Termination	26
OD Termination	27
CLKFWD Signal Groups	27
SYSCLK, SYSCLK#	27
6.7 Operating Ranges	28
6.8 Absolute Ratings	28
6.9 Power Dissipation	29
6.10 DC Characteristics	30
6.11 AC Characteristics	32

7	Mechanical Data	35
	7.1 Introduction	35
	7.2 Module Dimensions	35
	7.3 AMD Athlon™ Processor Card-Edge Signal Listing	41
8	Ordering Information	49
	Standard AMD Athlon™ Processor Products.....	49

Part Two

AMD Athlon Processor Model 2		51
9	Overview	53
	9.1 AMD Athlon™ Processor Microarchitecture Summary	54
10	Interface Signals	57
	10.1 Overview	57
	10.2 Signaling Technology	57
	10.3 AMD Athlon™ System Bus Signals	57
11	Logic Symbol Diagram	61
12	Power Management	63
13	Thermal Design	65
14	Electrical Data	67
	14.1 The AMD Athlon™ System Bus	67
	14.2 Signal Groupings	67
	Clock Forwarding.....	68
	14.3 Voltage Identification	69
	14.4 Frequency Identification	69
	14.5 Decoupling	69
	14.6 Termination	69
	14.7 Operating Ranges	70
	14.8 Absolute Ratings	70
	14.9 Power Dissipation	71
	14.10 DC Characteristics	72
	14.11 AC Characteristics	74
15	Mechanical Data	75
	15.1 Introduction	75
	15.2 AMD Athlon™ Processor Card-Edge Signal Listing	76
16	Ordering Information	83
	Standard AMD Athlon™ Processor Products.....	83
Appendix A	Conventions, Abbreviations, and References	85

List of Figures

Part One

Figure 1.	Typical AMD Athlon™ Processor System Block Diagram	3
Figure 2.	Logic Symbol Diagram	9
Figure 3.	AMD Athlon Processor Power Management States	11
Figure 4.	Example System Bus Disconnection Sequence	15
Figure 5.	Exiting Stop Grant State/Bus Reconnection Sequence	16
Figure 6.	System Connection States	18
Figure 7.	Processor Connection States	19
Figure 8.	Test Circuit	33
Figure 9.	AMD Athlon Processor Module Dimensions—Front View . . .	36
Figure 10.	AMD Athlon Processor Module Dimensions—Plate Side View	37
Figure 11.	AMD Athlon Processor Module Dimensions—Side View . . .	38
Figure 12.	AMD Athlon Processor Module Dimensions—Edge View . . .	38
Figure 13.	Card Edge Dimensions—Thermal Plate Side View	39
Figure 14.	Card Edge Dimensions (Detail)	40

Part Two

Figure 15.	Typical AMD Athlon Processor System Block Diagram	55
Figure 16.	Logic Symbol Diagram for AMD Athlon Processor Model 2 . .	61

List of Tables

Part One

Table 1.	Pin-Type Definitions	6
Table 2.	AMD Athlon™ System Bus and Legacy Interface Signals	6
Table 3.	AMD Athlon Processor Power Management States	14
Table 4.	AMD Athlon Processor Special Cycle Command Encodings	15
Table 5.	AMD Athlon Processor Interface Signal Groupings	24
Table 6.	Source-Synchronous Clock Signal Groups	24
Table 7.	Voltage ID Values	25
Table 8.	Signal and Clock Layout and Termination Requirements	26
Table 9.	Operating Ranges	28
Table 10.	Absolute Ratings	28
Table 11.	Typical and Maximum Power Dissipation	29
Table 12.	DC Characteristics	30
Table 13.	AC Characteristics	32
Table 14.	AMD Athlon Processor Module Dimensions	35
Table 15.	Notes for Dimension Drawings	35
Table 16.	AMD Athlon Processor Signals Ordered by Pin Number	41
Table 17.	AMD Athlon Processor Signals Ordered by Pin Name	44
Table 18.	AMD Athlon Processor Signals Ordered by Physical Location	47
Table 19.	Valid Ordering Part Number Combinations	49

Part Two

Table 20.	Pin-Type Definitions	58
Table 21.	AMD Athlon System Bus and Legacy Interface Signals	58
Table 22.	AMD Athlon Processor Interface Signal Groupings	68
Table 23.	Source-Synchronous Clock Signal Groups	68
Table 24.	Operating Ranges	70
Table 25.	Absolute Ratings	70
Table 26.	Typical and Maximum Power Dissipation	71
Table 27.	DC Characteristics	72

Table 28.	AMD Athlon Processor Signals Ordered by Pin Number	76
Table 29.	AMD Athlon Processor Signals Ordered by Pin Name	79
Table 30.	AMD Athlon Processor Signals Ordered by Physical Location	82
Table 31.	Valid Ordering Part Number Combinations	83
Table 32.	Abbreviations	87
Table 33.	Acronyms	88

Revision History

Date	Rev	Description
August 1999	D	Initial public release
August 1999	E	Revised VCC_CORE minimum value from 1.4V to 1.5V in Table 9, "Operating Ranges," on page 28. Revised information in Table 10, "Absolute Ratings," on page 28. Revised information in Table 11, "Typical and Maximum Power Dissipation (Model 1)," on page 29.
October 1999	F	Added the 700 MHz AMD Athlon™ processor to Table 11, "Typical and Maximum Power Dissipation (Model 1)," on page 29 and Table 19, "Valid Ordering Part Number Combinations," on page 49. Revised Table 12, "DC Characteristics (Model 1)," on page 30 and Table 13, "AC Characteristics," on page 32.
December 1999	G	Divided book into Part One and Part Two. Part One provides information about the AMD Athlon™ processor family (Model 1 and Model 2), and Part Two provides information specific to the AMD Athlon processor Model 2 (0.18-micron process technology). Revisions to Part One: In Chapter 6, "Electrical Data" on page 23: <ul style="list-style-type: none"> ■ Expanded information in the "Termination" section starting on page 26, including the addition of Table 8, "Signal and Clock Layout and Termination Requirements". ■ Revised maximum rating in Table 10, "Absolute Ratings," on page 28. ■ Revised Stop Grant values in Table 11, "Typical and Maximum Power Dissipation (Model 1)," on page 29. ■ Added I_{CC} values and notes 7 and 8 to Table 12, "DC Characteristics (Model 1)," on page 30. In Chapter 7, "Mechanical Data" on page 35, added # to SCHECK[2]# and SCHECK[7]# in signal Tables 16, 17, and 18 starting on page 41.

About This Data Sheet

The AMD Athlon™ processor data sheet supports the Model 1 and Model 2 versions of the AMD Athlon processor family. Model 1 refers to the AMD Athlon manufactured in the 0.25-micron process technology and Model 2 refers to the AMD Athlon manufactured in the 0.18-micron process technology. The data sheet is divided into two parts. Part One (chapters 1–8) contains information that pertains to the entire AMD Athlon processor family and information specific to the Model 1. Part Two (chapters 9–16) contains information regarding new specifications and differences that pertain only to Model 2 as compared to Model 1.

Part One

AMD Athlon™ Processor Family

The AMD Athlon processor data sheet supports the Model 1 and Model 2 versions of the AMD Athlon processor family. Model 1 refers to the AMD Athlon manufactured with 0.25-micron process technology and Model 2 refers to the AMD Athlon manufactured with 0.18-micron process technology. Part One (chapters 1–8) contains information that pertains to the entire AMD Athlon desktop family and information specific to Model 1. For information about Model 2, see Part Two, “AMD Athlon™ Processor Model 2” on page 51.

1 Overview

The AMD Athlon™ processor powers the next generation in computing platforms, delivering the ultimate performance for cutting-edge applications and an unprecedented computing experience.

The AMD Athlon processor is the first member of a new family of seventh-generation AMD processors designed to meet the computation-intensive requirements of cutting-edge software applications running on high-performance desktop systems, workstations, and servers.

The AMD Athlon processor is the world's most powerful x86 processor, delivering the highest integer, floating-point and 3D multimedia performance for applications running on x86 system platforms. The AMD Athlon provides industry-leading processing power for cutting-edge software applications, including digital content creation, digital photo editing, digital video, image compression, video encoding for streaming over the internet, soft DVD, commercial 3D modeling, workstation-class computer-aided design (CAD), commercial desktop publishing, and speech recognition. It also offers the scalability and 'peace-of-mind' reliability that IT managers and business users require for enterprise computing.

The AMD Athlon processor features the industry's first seventh-generation x86 microarchitecture, which is designed to support the growing processor and system bandwidth requirements of emerging software, graphics, I/O, and memory technologies. The AMD Athlon processor's high-speed execution core includes multiple x86 instruction decoders, a dual-ported 128-Kbyte split level-one (L1) cache, three independent integer pipelines, three address calculation pipelines, and the x86 industry's first superscalar, fully pipelined, out-of-order, three-way floating-point engine. The floating-point engine is capable of delivering 2.4 gigaflops (Gflops) of single-precision and more than 1 Gflop of double-precision floating-point results at 600 MHz, for superior performance on numerically complex applications.

The AMD Athlon processor microarchitecture incorporates enhanced 3DNow!™ technology, a high-performance cache architecture, and a 200-MHz, 1.6-Gigabyte per second system bus—the first bus of its kind for x86 system platforms. Based on

the Alpha™ EV6 interface protocol licensed from Digital Equipment Corporation, the AMD Athlon system bus combines the latest technological advances, such as point-to-point topology, source-synchronous packet-based transfers, and low-voltage signaling, to provide the most powerful, scalable bus available for any x86 processor.

The AMD Athlon processor is binary-compatible with existing x86 software and backwards compatible with applications optimized for MMX™ and 3DNow! instructions. Using a data format and single-instruction multiple-data (SIMD) operations based on the MMX instruction model, the AMD Athlon processor can produce as many as four, 32-bit, single-precision floating-point results per clock cycle, potentially resulting in 2.4 Gflops at 600 MHz (fully scalable). The enhanced 3DNow! technology implemented in the AMD Athlon includes new integer multimedia instructions and software-directed data movement instructions for optimizing such applications as digital content creation and streaming video for the internet, as well as new instructions for digital signal processing (DSP)/communications applications.

1.1 AMD Athlon™ Processor Microarchitecture Summary

The following features summarize the AMD Athlon processor microarchitecture:

- The industry's first nine-issue, superpipelined, superscalar x86 processor microarchitecture designed for high clock frequencies
- Multiple x86 instruction decoders
- Three out-of-order, superscalar, fully pipelined floating-point execution units, which execute all x87 (floating-point), MMX and 3DNow! instructions
- Three out-of-order, superscalar, pipelined integer units
- Three out-of-order, superscalar, pipelined address calculation units
- 72-entry instruction control unit
- Advanced dynamic branch prediction
- Enhanced 3DNow! technology with new instructions to enable improved integer math calculations for speech or video encoding and improved data movement for internet plug-ins and other streaming applications

2 Interface Signals

2.1 Overview

The AMD Athlon system bus architecture is designed to deliver unprecedented data movement bandwidth for next-generation x86 platforms, as well as the high performance required by enterprise-class application software. The system bus architecture consists of three high-speed channels (a unidirectional processor request channel, a unidirectional probe channel, and a 72-bit bidirectional data channel, including 8-bit error code correction [ECC] protection), source-synchronous clocking, and a packet-based protocol. In addition, the system bus supports several control, clock, and legacy signals. The interface signals use a HSTL-like, low-voltage swing signaling technology contained within the Slot A mechanical connector, which is mechanically compatible with the industry-standard SC242 connector.

2.2 Signaling Technology

The AMD Athlon system bus uses a variation of the low-voltage, JEDEC HSTL signaling technology, which has been enhanced to provide larger noise margins, reduced ringing, and variable voltage levels. The signals are open-drained and require termination to a supply that provides the High signal level. The HSTL+ inputs use differential receivers, which require a reference voltage (V_{REF}). The reference signal is used by the receivers to determine if a signal is asserted or deasserted by the source. Termination resistors are placed at both ends of the interface and are used to provide the High signal level and to control reflections on the interface.

2.3 AMD Athlon™ System Bus Signals

Table 2 on page 6 shows the AMD Athlon system bus signals and legacy interface signals. Table 1 on page 6 shows the pin-type definitions used in the *Type* column of Table 2.

Table 1. Pin-Type Definitions

Mnemonic	Definition
I	Standard input pin to the processor
O	Standard output pin from the processor
I/O	Bidirectional, three-state input/output pin
OD	Open-drain structure that allows multiple devices to share the pin in a wired-OR configuration
PP	Push/Pull structure driven by a single source
V _{CCCORE}	AMD Athlon processor core voltage

Table 2. AMD Athlon™ System Bus and Legacy Interface Signals

Signal Name	Type	Level	Number of Pins	Description
A20M#	I	OD V _{CCCORE}	1	A20M# is an input from the system used to simulate address wrapping around in the 20-bit 8086.
CLKFWRST	I	OD V _{CCCORE}	1	CLKFWRST resets clock-forward circuitry for both the system and processor.
CONNECT	I	OD V _{CCCORE}	1	CONNECT is an input from the system used for power management and clock-forward initialization at reset.
COREFB+ COREFB-	O	PP V _{CCCORE}	2	COREFB+ and COREFB- are outputs to the system that provide AMD Athlon processor core voltage feedback to the system.
FERR	O	OD V _{CCCORE}	1	FERR is an output to the system that is asserted for any unmasked numerical exception independent of the NE bit in CR0.
FID[3:0]	O	OD V _{CCCORE}	4	The FID[3:0] signals are outputs to the system that report the multiplier used on the system clock (SYSCLK) producing the AMD Athlon processor core clock.
IGNNE#	I	OD V _{CCCORE}	1	IGNNE# is an input from the system that tells the processor to ignore numeric errors.
INIT#	I	OD V _{CCCORE}	1	INIT# is an input from the system that resets the integer registers without affecting the floating-point registers or the internal caches. Execution starts at 0FFFF FFF0h.
INTR	I	OD V _{CCCORE}	1	INTR is an input from the system that causes the processor to start an interrupt acknowledge transaction that fetches the 8-bit interrupt vector and starts execution at that location.
NMI	I	OD V _{CCCORE}	1	NMI is an input from the system that causes a non-maskable interrupt.

Table 2. AMD Athlon™ System Bus and Legacy Interface Signals (continued)

Signal Name	Type	Level	Number of Pins	Description
PROCRDY	O	OD V _{CC} CORE	1	PROCRDY is an output to the system and is used for power management and source-synchronous clock initialization at reset.
PWROK	I	OD V _{CC} CORE	1	PWROK is an input from the system indicating that the core power is within specified limits.
RESET#	I	OD V _{CC} CORE	1	RESET# is an input from the system that initializes and resets the processor and invalidates cache blocks.
SADDIN[14:2]#	I	OD V _{CC} CORE	13	SADDIN[14:2]# is the unidirectional system probe and data movement command channel from the system.
SADDINCLK#	I	OD V _{CC} CORE	1	SADDINCLK# is the single-ended source-synchronous clock for SADDIN[14:2]# and is driven by the system.
SADDOUT[14:2]#	O	OD V _{CC} CORE	13	SADDOUT[14:2]# is the unidirectional processor request channel to the system. It is used to transfer processor requests or probe responses to the system.
SADDOUTCLK#	O	OD V _{CC} CORE	1	SADDOUTCLK# is the single-ended source-synchronous clock for SADDOUT[14:2]# driven by the processor.
SCHECK[7:0]#	I/O	OD V _{CC} CORE	8	SCHECK[7:0]# contain the ECC bits for data transfers on SDATA[63:0]#.
SDATA[63:0]#	I/O	OD V _{CC} CORE	64	SDATA[63:0]# is the bidirectional channel between the processor and system for data movement.
SDATAINCLK[3:0]#	I	OD V _{CC} CORE	4	SDATAINCLK[3:0]# is the single-ended forwarded clock driven by the system to transfer data on SDATA[63:0]#. Each 16-bit data word is skewed-aligned with this clock.
SDATAINVAL#	I	OD V _{CC} CORE	1	SDATAINVAL# is driven by the system to pace the data into the processor. SDATAINVAL# can be used to introduce an arbitrary number of cycles between octawords into the processor.
SDATAOUTCLK[3:0]#	O	OD V _{CC} CORE	4	SDATAOUTCLK[3:0]# is the single-ended source-synchronous clock driven by the processor to transfer data on SDATA[63:0]#. Each 16-bit data word on SDATA[63:0]# is skewed-aligned with this clock.
SDATAOUTVAL#	I	OD V _{CC} CORE	1	SDATAOUTVAL# is driven by the system to pace the data from the processor. SDATAOUTVAL# can be used to introduce an arbitrary number of cycles between quadwords from the processor.
SFILLVAL#	I	OD V _{CC} CORE	1	SFILLVAL# validates a data transfer to the processor. The system may tie this pin to the asserted state (validating all fills). The processor samples SFILLVAL# at the first or second data beat.

Table 2. AMD Athlon™ System Bus and Legacy Interface Signals (continued)

Signal Name	Type	Level	Number of Pins	Description
SMI#	I	OD V _{CCCORE}	1	SMI# is an input that causes the processor to enter the system management mode.
STPCLK#	I	OD V _{CCCORE}	1	STPCLK# is an input that causes the processor to enter a lower power mode and issue a Stop Grant special cycle.
SYSCLK SYSCLK#	I		2	SYSCLK and SYSCLK# are differential input clock signals provided to the processor's PLL from a system-clock generator.
VCC2SEL	O	OD V _{CCCORE}	1	VCC2SEL is an output to the system that indicates the required core voltage for the L2 SRAM. High=2.5V, Low=3.3V.
VID[3:0]	O	OD V _{CCCORE}	4	The VID[3:0] signals are outputs to the motherboard that indicate the required V _{CCCORE} voltage for the processor.

3 Logic Symbol Diagram

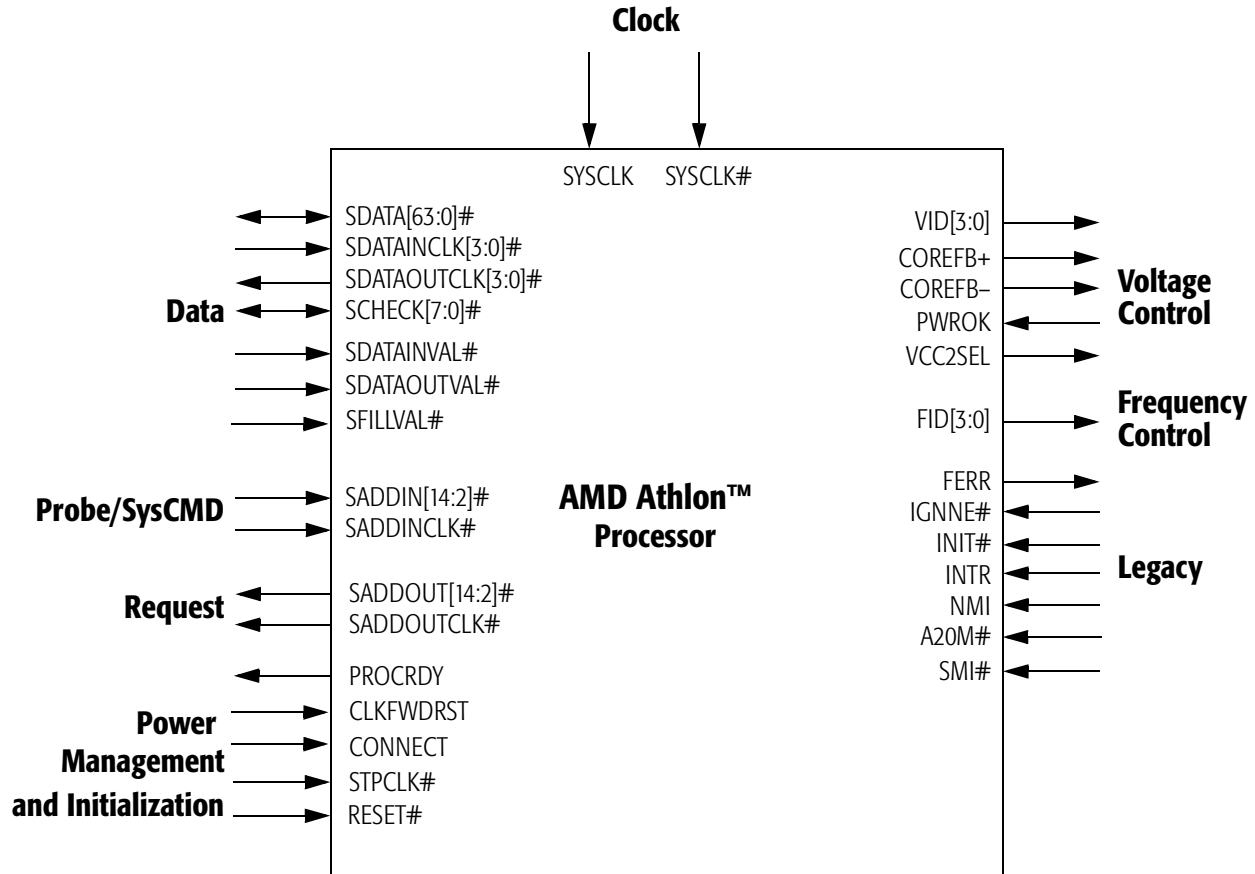
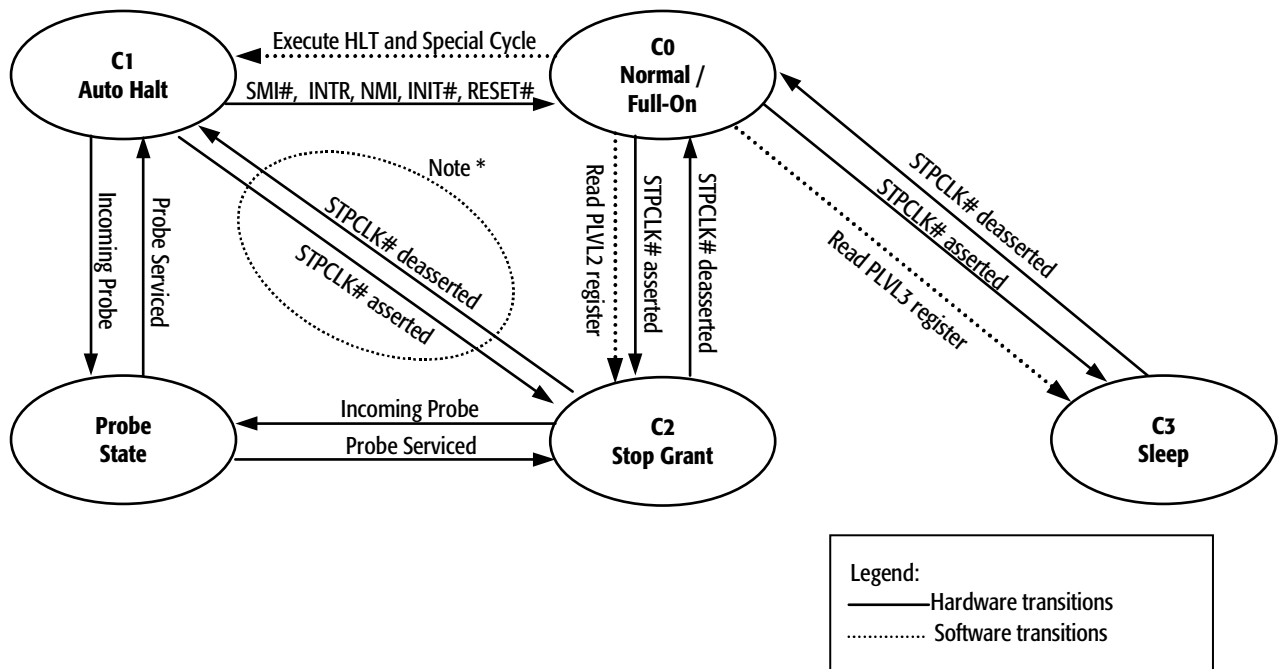

Figure 2. Logic Symbol Diagram

4 Power Management

4.1 Power Management States

The AMD Athlon processor uses multiple advanced power states to place the processor in reduced power modes. These power states are used to enhance processor performance, minimize power dissipation, and provide a balance between performance and power (see “Power Dissipation” on page 29 for more information). In addition, these power states conform to the industry-standard Advanced Configuration and Power Interface (ACPI) requirements for processor power states. (ACPI is a specification for system hardware and software to support OS-oriented power management.) Each state has a specific mechanism that allows the processor to enter the respective state. Figure 3 shows the power management states of the AMD Athlon processor. The figure includes the ACPI power states for the processor, labeled as Cx.



Note: The C1 to C2 transition by way of the STPCLK# assertion/deassertion is not defined for ACPI-compliant systems.

Figure 3. AMD Athlon™ Processor Power Management States

The following sections describe each of the low-power states.

Note: *In all power management states, the system must not disable the system clock (SYSCLK/SYSCLK#) to the processor.*

Full-On

The Full-on or normal state refers to the default power state and means that all functional units are operating at full processor clock speed.

Halt State

When the AMD Athlon processor executes the HLT instruction, the processor issues a Halt special cycle to the system bus. The phase-lock loop (PLL) continues to run, enabling the processor to monitor bus activity and provide a quick resume from the Halt state. The processor may enter a lower power state.

The Halt state is exited when the processor samples INIT#, INTR (if interrupts are enabled), NMI, RESET#, or SMI#.

Stop Grant and Sleep States

After recognizing the assertion of STPCLK#, the AMD Athlon processor completes all pending and in-progress bus cycles and acknowledges the STPCLK# assertion by issuing a Stop Grant special bus cycle to the system bus. The processor may enter a lower power state.

From a software standpoint, the Sleep/Stop Grant state is entered by reading the PLVL registers located in an ACPI-compliant peripheral bus controller. The difference between the Stop Grant state and the Sleep state is determined by which PLVL register software reads from the peripheral bus controller. If the software reads the PLVL_2 register, the processor enters the Stop Grant state. In this state, probes are allowed, as shown in Figure 3 on page 11. If the software reads the PLVL_3 register, the processor enters the Sleep state, where probes are not allowed. This action is accomplished by disabling snoops within an ACPI-compliant system controller.

The Sleep/Stop Grant state is exited upon the deassertion of STPCLK# or the assertion of RESET#. After the processor enters the Full-on state, it resumes execution at the instruction boundary where STPCLK# was initially recognized.

The processor latches INIT#, INTR (if interrupts are enabled), NMI, and SMI#, if they are asserted during the Stop Grant or Sleep state. However, the processor does not exit this state until the deassertion of STPCLK#. When STPCLK# is deasserted,

any pending interrupts are recognized after returning to the Normal state.

If RESET# is sampled asserted during the Stop Grant or Sleep state, the processor immediately returns to the Full-on state and the reset process begins.

Probe State

The Probe state is entered when the system requires the processor to service a probe. When in the Probe state, the processor responds to a probe cycle in the same manner as when it is in the Full-on state.

When the probe has been serviced, the processor returns to the same state as when it entered the Probe state.

4.2 Connection and Disconnection Protocol

The AMD Athlon processor enhances power savings in each of the power management states when the system logic disconnects the processor from the system bus and slows down the internal clocks. Entering the lowest power state is accomplished with a connection protocol between the processor and system logic. The system can initiate a bus disconnection upon the receipt of a Stop Grant special cycle. If required by the system, the processor disconnects from the system bus and slows down its internal clocks before entering the Stop Grant or Sleep state. If the system requires the processor to service a probe while it is in the Stop Grant state, it must first request that the processor increase its clocks to full speed and reconnect to the system bus. Table 3 on page 14 describes the AMD Athlon processor power states using the connection protocol as described on page 14.

AMD Athlon system bus connections and disconnections are controlled by an enable bit within the system controller.

Table 3. AMD Athlon™ Processor Power Management States

State Name	Entered	Exited
Full-On / Normal	This is the full-on running state of the processor	Initiates either a Halt instruction or STPCLK# assertion.
Halt	Execution of the Halt instruction. A special cycle is issued. The processor may enter a lower power state.	The processor exits and returns to the Run state upon the occurrence of INIT#, INTR, NMI, SMI# or RESET#. The processor transitions to the Stop Grant state if STPCLK# is asserted and returns to the Halt state upon STPCLK# deassertion.
Stop Grant	The processor transitions to the Stop Grant state with the assertion of STPCLK# (as a result of a read to the PLVL_2 register). A Stop Grant special cycle is issued. The processor may enter a lower power state. Note: While in this state, interrupts are latched and serviced when the processor transitions to the Full-on state.	The processor transitions to the Full-on or Halt state upon STPCLK# deassertion. RESET# asserted initializes the processor but, if STPCLK# is asserted, the processor returns to the Stop Grant state.
Probe	A transition to the Probe state occurs when the system asserts CONNECT. The processor remains in this state until the probe is serviced and any data is transferred.	The processor returns to the Halt or Stop Grant state when the probe has been serviced and the system deasserts CONNECT. If the processor was disconnected from the bus in the previous state, bus disconnection occurs and the internal frequency of the processor is again slowed down.
Sleep	The processor can enter its lowest power state, Sleep, from the Full-on state with the assertion of STPCLK# (as a result of a read to the PLVL_3 register). Note: While in this state, interrupts are latched and serviced when the processor transitions to the Full-on state.	The processor transitions to the Run state upon STPCLK# deassertion. Asserting RESET# initializes the processor but, if STPCLK# is asserted, the processor returns to the Sleep state.

Connection Protocol

In addition to the legacy STPCLK# signal and the Halt and Stop Grant special cycles, the AMD Athlon system bus connection protocol includes the CONNECT, PROCRDY, and CLKFWDRST signals and the new *Connect* special cycle.

AMD Athlon system bus disconnects are initiated by the system controller in response to the receipt of a Stop Grant special cycle. Reconnections are initiated by the processor in response to an interrupt or STPCLK# deassertion, or by the system to service a probe.

A disconnect request is implicit, if enabled, in the processor Stop Grant special cycle request. It is expected that the system controller provides a BIOS-programmable register in which it

can disconnect the processor from the AMD Athlon system bus upon the occurrence of a Stop Grant special cycle. The system receives the special cycle request from the processor and, if there are no outstanding probes or data movements, the system deasserts CONNECT to the processor. The processor detects the deassertion of CONNECT on a rising edge of SYSCLK, and deasserts PROCRDY to the system. In return, the system asserts CLKFWDRST in anticipation of reestablishing a connection at some later point.

Note: The system must disconnect the processor from the AMD Athlon system bus before issuing the Stop Grant special cycle to the PCI bus.

The processor can receive an interrupt or STPCLK# deassertion after it sends a Stop Grant special cycle to the system but before the disconnection actually occurs. In this case, the processor sends the Connect special cycle to the system, rather than continuing with the disconnect sequence. The system cancels the disconnection. Table 4 describes the Connect special cycle command.

Table 4. AMD Athlon™ Processor Special Cycle Command Encodings

Special Cycle Type	AMD Athlon™ System Bus CMD	PA [34:0]	SysData [31:0]	Description
Connect	WrLWs	SpecCycBase	0004 0002	The processor generates this special cycle to initiate a reconnect of the interface. The system returns CONNECT to the asserted state

Figure 4 shows the sequence of events from a system perspective, which leads to disconnecting the processor from the AMD Athlon system bus and placing the processor in the Stop Grant state.

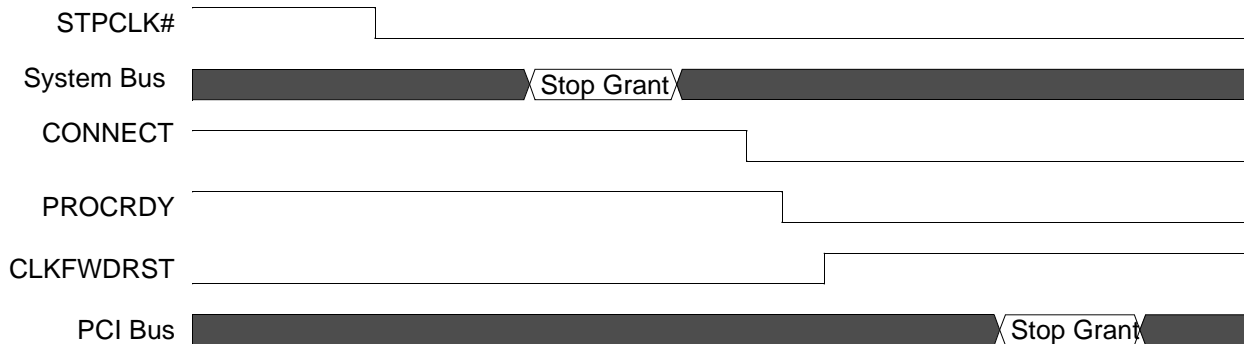

Figure 4. Example System Bus Disconnection Sequence

The following sequence of events describes how the processor is placed in the Stop Grant state when bus disconnection is enabled within the system controller:

1. The peripheral controller asserts STPCLK# to place the processor in the Stop Grant state.
2. When the processor receives STPCLK#, it acknowledges the system by sending out a Stop Grant special bus cycle on the AMD Athlon system bus.
3. When the special cycle is received by the system controller, the system controller deasserts CONNECT, initiating a bus disconnect to the processor.
4. The processor replies to the system controller by deasserting PROCRDY, approving the bus disconnect request.
5. The system controller asserts CLKFWDRST to complete the bus disconnection sequence.
6. After the processor is disconnected from the bus, the system controller passes the Stop Grant special cycle along to the peripheral controller via the PCI bus, notifying it that the processor is in the Stop Grant state.

Figure 5 shows the signal sequence of events that take the processor out of the Stop Grant state, reconnect the processor to the AMD Athlon system bus, and put the processor into the Full-on state.

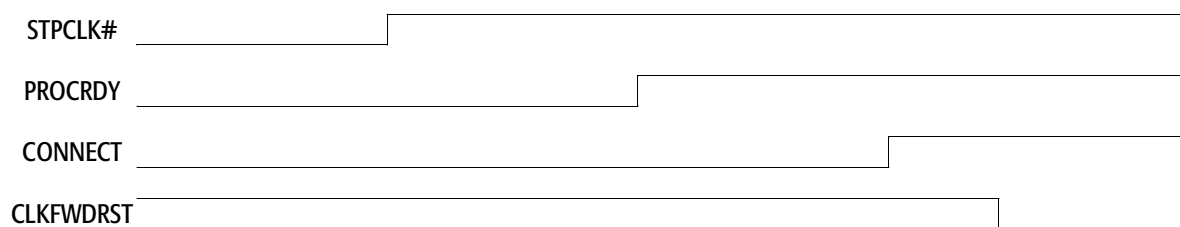

Figure 5. Exiting Stop Grant State/Bus Reconnection Sequence

The following sequence of events removes the processor from the Stop Grant state and reconnects it to the AMD Athlon system bus:

1. The peripheral controller deasserts STPCLK#, informing the processor of a wake event.

2. When the processor receives STPCLK#, it asserts PROCRDY, notifying the system controller to reconnect to the bus.
3. The system controller asserts CONNECT, telling the processor that it is connected to the AMD Athlon system bus.
4. The system controller finally deasserts CLKFWRST, which synchronizes the forwarded clocks between the processor and the system controller.

Connection State Machines

Figure 6 and Figure 7 describe the system and processor connection state machines, respectively.

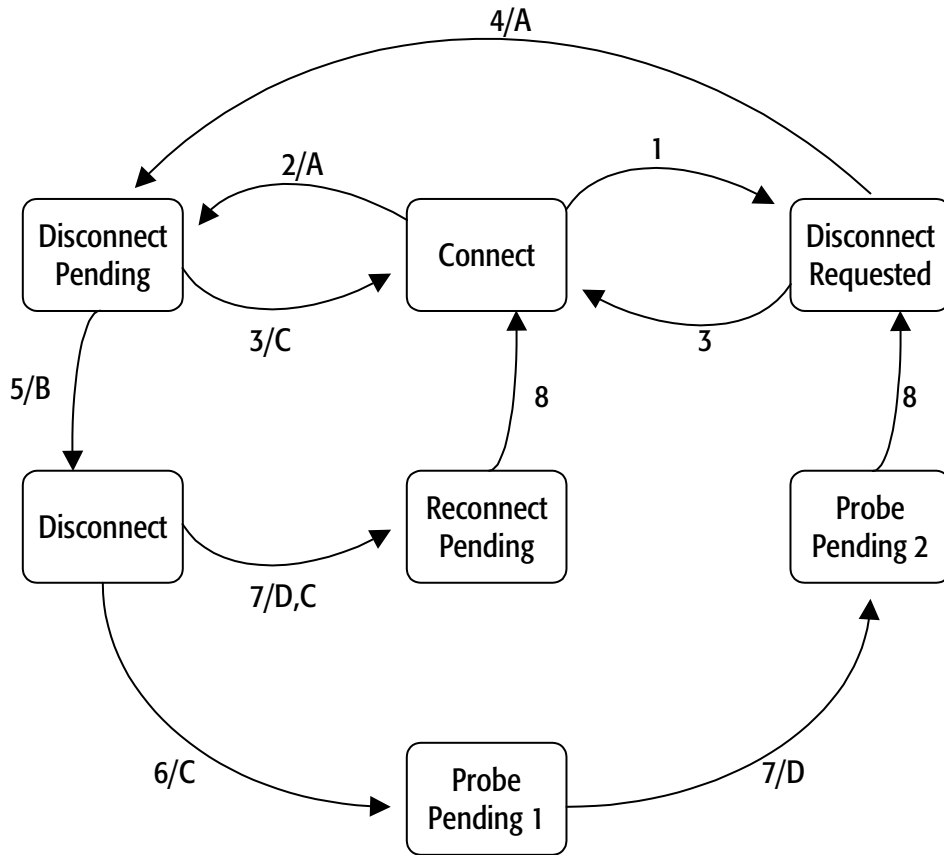

	Condition
1	A disconnect is requested and probes are still pending
2	A disconnect is requested and no probes are pending
3	A CONNECT special cycle from the processor
4	No probes are pending
5	PROCRDY is deasserted
6	A probe needs service
7	PROCRDY is asserted
8	3 SYSCLK periods after CLKFWRST is deasserted. <i>Although reconnected to the system interface, the system must not issue any non-NOP SysDC commands for a minimum of four SYSCLK periods after deasserting CLKFWRST.</i>

	Action
A	Deassert CONNECT 8 SYSCLK periods after last probe/command sent
B	Assert CLKFWRST
C	Assert CONNECT
D	Deassert CLKFWRST

Figure 6. System Connection States

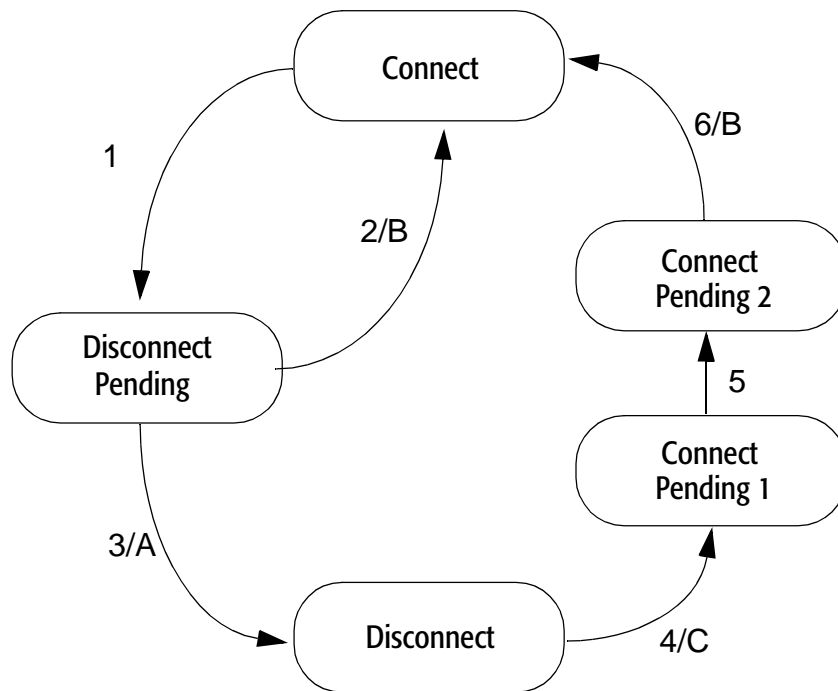

	Condition
1	CONNECT is deasserted by the system (for a previously sent Halt or Stop Grant special cycle).
2	Processor receives a wake-up event and must cancel the disconnect request.
3	Deassert PROCRDY and slow down internal clocks.
4	Processor wake-up event or CONNECT asserted by system.
5	CLKFWRST is deasserted by the system
6	Forward clocks start 3 SYSCLK periods after CLKFWRST is deasserted.

	Action
A	CLKFWRST is asserted by the system.
B	Issue a CONNECT special cycle.
C	Assert PROCRDY and return internal clocks to full speed

Figure 7. Processor Connection States

5 Thermal Design

For information about thermal design, including layout and airflow considerations, see the *AMD Athlon™ Processor Thermal Solution Design Application Note*, order# 22439.

6 Electrical Data

6.1 The AMD Athlon™ System Bus

The AMD Athlon system bus architecture is designed to deliver unprecedented data movement bandwidth for next-generation x86 platforms, as well as the high performance required by enterprise-class application software. The system bus architecture consists of three high-speed channels (a unidirectional processor request channel, a unidirectional snoop channel, and a 72-bit bidirectional data channel, including 8-bit error code correction [ECC] protection), source-synchronous clocking, and a packet-based protocol. In addition, the system bus supports several control, clock, and legacy signals. The interface signals use a HSTL-like, low-voltage swing signaling technology contained within the Slot A mechanical connector, which is mechanically compatible with the industry-standard SC242 connector.

6.2 Signal Groupings

The AMD Athlon system bus is the processor connection to a memory and I/O controller or a shared multiprocessor controller. The system interface can be broken down into four signal groups plus power and ground connections. These groups are listed in Table 5 on page 24. The first group connects the AMD Athlon processor to the system controller and uses a source-synchronous, or clock-forwarded clocking scheme. Using this technique, the clocks and data travel in the same direction down the transmission line and arrive together. The second group connects the AMD Athlon processor to the peripheral bus controller, but unlike the system controller group, these signals do not use a source-synchronous scheme. The third group is the control group, which contains signals that interface with the power supply of the system. The fourth group contains the system clock. This is the input clock for the AMD Athlon and is the source for all other clocks generated by the AMD Athlon processor module.

Table 5. AMD Athlon™ Processor Interface Signal Groupings

Name	Buffer Type	Signals
System Controller (Northbridge)	Open-Drain	SADDIN[14:2]#, SADDOUT[14:2]#, SADDINCLK#, SADDOUTCLK#, SFILLVAL#, SDATAINVAL#, SDATAOUTVAL#, SDATA[63:0]#, SDATAINCLK[3:0]#, SDATAOUTCLK[3:0]#, SCHECK[7:0]#, FID[3:0], CLKFWRST, PROCRDY, CONNECT
Peripheral Bus Controller (Southbridge)		RESET#, INTR, NMI, SMI#, INIT#, A20M#, FERR, IGNNE#, STPCLK#
Clock		SYSCLK, SYSCLK#
Control		VID[3:0], VCC2SEL, COREFB+, COREFB-, PWROK
Power		VCC_CORE, VCC_SRAM, GND

Clock Forwarding

The signals in the system controller group can be divided into six source-synchronous groups, as shown in Table 6. Groups that contain two clocks are bidirectional, source-synchronous groups. These groups use a different clock, based on the operation being performed. For example, when data is sent from the AMD Athlon to the system controller, SDATAOUTCLK# is used, and when data is sent from the system controller to the AMD Athlon processor, SDATAINCLK# is used. The topology is point-to-point and active terminations.

Table 6. Source-Synchronous Clock Signal Groups

Group	Signals in Group	Clock
SData0	SDATA[15:0]#, SCHECK[0:1]#	SDATAINCLK[0]#, SDATAOUTCLK[0]#
SData1	SDATA[31:16]#, SCHECK[2:3]#	SDATAINCLK[1]#, SDATAOUTCLK[1]#
SData2	SDATA[47:32]#, SCHECK[4:5]#	SDATAINCLK[2]#, SDATAOUTCLK[2]#
SData3	SDATA[63:48]#, SCHECK[6:7]#	SDATAINCLK[3]#, SDATAOUTCLK[3]#
SAddIn	SADDIN[14:2]#, SFILLVAL#, SDATAINVAL#, SDATAOUTVAL#	SADDINCLK#
SAddOut	SADDOUT[14:2]#	SADDOUTCLK#

6.3 Voltage Identification

The AMD Athlon processor provides four voltage ID lines back to the system for proper configuration of the processor core voltage. The processor either connects a VID to V_{SS} , or has an open value. If required by the voltage regulator, the motherboard pulls up these four signals up to TTL levels. The motherboard is required to pull VID[4] Low for the voltage regulator to supply voltage in the appropriate range for the AMD Athlon. These voltage ID values are defined in Table 7. The pullup resistors used on the motherboard must have a value of at least 10 k Ω .

Table 7. Voltage ID Values

VID[3]	VID[2]	VID[1]	VID[0]	VCC_CORE (V)
0	0	0	0	2.05
0	0	0	1	2.00
0	0	1	0	1.95
0	0	1	1	1.90
0	1	0	0	1.85
0	1	0	1	1.80
0	1	1	0	1.75
0	1	1	1	1.70
1	0	0	0	1.65
1	0	0	1	1.60
1	0	1	0	1.55
1	0	1	1	1.50
1	1	0	0	1.45
1	1	0	1	1.40
1	1	1	0	1.35
1	1	1	1	1.30

In addition, the AMD Athlon processor provides the VCC2SEL signal to identify the core voltage of the L2 cache SRAMs. Like the VID signals, the AMD Athlon either connects the VCC2SEL to V_{SS} or has an open value, with a pullup resistor on the motherboard. An open value indicates that a voltage of 2.5V is required for VCC_SRAM, while a V_{SS} indicates a required voltage of 3.3V.

6.4 Frequency Identification

The AMD Athlon processor provides four frequency ID signals (FID[3:0]) to the system controller to indicate the SYSCLK multiplier at which the processor core operates. This mechanism is automatic, using the system controller and the BIOS without jumpers on the motherboard to set the operating frequency of the AMD Athlon.

6.5 Decoupling

See the *AMD Athlon™ Processor Voltage Regulation Design Application Note*, order# 22651, or contact your local AMD office for information about the decoupling required on the motherboard for use with the AMD Athlon processor.

6.6 Termination

Table 8 lists the layout and termination for Slot-A signals and clocks.

For additional information concerning termination design guidelines for AMD Athlon processor-based systems, contact your local AMD representative to obtain detailed documentation available under a non-disclosure agreement.

Table 8. Signal and Clock Layout and Termination Requirements

Group/Name	Termination Requirements
SYSCLK, SYSCLK#	Differential clock inputs to the system controller (Northbridge) and Slot-A. Point-to-point system clocks driven by the central system clock generator. See "SYSCLK, SYSCLK#" on page 27.
SDATA0, SDATA1, SDATA2, SDATA3, SADDIN, SADDOUT*	68 ohm pullup resistors must be kept with 1" of Northbridge. See "OD Termination" on page 27.
CLKFWRST, CONNECT, PROCRDY	
PICCLK	These signals must be pulled to 2.5 V on the motherboard using a 330-ohm resistor to Vcc3 and a 1.0-kohm resistor to Vss.
PICD[1:0]	
NMI, INTR, SMI#, INIT#, A20M#, IGNNE#, STPCLK#, CPURESET#	Route to minimum length where possible. HSTL-like inputs. Point-to-point signals driven by the peripheral bus controller (Southbridge) to the Slot-A connector. These signals are pulled to VccCore on the Slot-A card and do not require termination on the motherboard.
Notes:	
* See Table 6, "Source-Synchronous Clock Signal Groups," on page 24	

OD Termination

Both the processor and Northbridge use HSTL-like open-drain outputs and HSTL-like inputs. Therefore, the bus signals must be terminated both at the source and the destination with 68Ω pullup resistors to VccCore. Pullups at the processor are located on the processor module and need not be considered during motherboard layout. Consequently, the only terminations required on the motherboard are the pullup resistors at the Northbridge. These pullup termination resistors must be located 1 inch from the Northbridge.

For systems that do not support ECC, SCHECK[7:0]# should be tied to VccCore with a 68-ohm pullup, with minimal routing where possible.

CLKFWD Signal Groups

The termination scheme for all clock forward signals, both signal and clock, involves having each end terminated by a 68-ohm pullup resistor located 1 inch from each device. Pullups at the processor are located on the processor module and need not be considered during motherboard layout.

Note: The data bus, SDATA[63:0], drives in both directions and, therefore, must have a unidirectional clock for each data group travelling each way.

SYSCLK, SYSCLK#

Each of the two SYSCLK pairs from the clock generator to the processor, SYSCLK and SYSCLK# (true and complimentary), are series terminated at the source with a 47-ohm resistor located a maximum distance of 0.5 inch from the clock generator and parallel terminated at the end with a 68-ohm resistor to VccCore. Parallel termination occurs on the processor module and need not be considered during motherboard layout.

6.7 Operating Ranges

The AMD Athlon processor is designed to provide functional operation if the voltage and temperature parameters are within the limits defined in Table 9.

Table 9. Operating Ranges

Parameter	Description	Min	Max	Notes
VCC_CORE	AMD Athlon™ processor core supply	1.5 V	1.7 V	1
VCC_CORE	AMD Athlon™ processor core supply in Sleep state	1.2 V	1.7 V	2
VCC_SRAM	2.5 V SRAM core supply	2.475 V	2.625 V	3
VCC_SRAM	3.3 V SRAM core supply	3.15 V	3.45 V	4
T _{PLATE}	Temperature of thermal plate		70° C	
Notes: <ol style="list-style-type: none"> For normal operating conditions (nominal VCC_CORE is 1.6 V) For Sleep state operating conditions Value of VCC_SRAM when VCC2SEL is High Value of VCC_SRAM when VCC2SEL is Low 				

6.8 Absolute Ratings

The AMD Athlon processor should not be subjected to conditions exceeding the absolute ratings listed in Table 10, as such conditions may adversely affect long term reliability or result in functional damage.

Table 10. Absolute Ratings

Parameter	Description	Min	Max	Notes
VCC_CORE	AMD Athlon™ processor core supply	-0.5 V	nominal + 0.5 V	
VCC_SRAM	2.5 V SRAM core supply	-0.5 V	3.0 V	1
VCC_SRAM	3.3 V SRAM core supply	-0.5 V	4.0 V	2
V _{PIN}	Voltage on any system bus pin	TBD	TBD	
T _{STORAGE}	Storage temperature of processor	-40° C	85° C	
Notes: <ol style="list-style-type: none"> Value of VCC_SRAM when VCC2SEL is Low Value of VCC_SRAM when VCC2SEL is High 				

6.9 Power Dissipation

Table 11 shows the typical and maximum power dissipation of the AMD Athlon processor during normal and reduced power states.

Table 11. Typical and Maximum Power Dissipation (Model 1)

Clock Control State	500 MHz	550 MHz	600 MHz	650 MHz	700 MHz	Note
Normal (Maximum Thermal Power)	42 W	46 W	50 W	54 W	50 W	1, 2
Normal (Typical Thermal Power)	38 W	41 W	45 W	48 W	45 W	1, 2
Stop Grant (Maximum)	6 W	6 W	6 W	6 W	6 W	3
Notes: 1) Power numbers include power for a 512-Kbyte L2 cache running at maximum case current conditions. 2) Measured at 1.6V nominal 3) Measured at 1.3V for Sleep state operating conditions						

6.10 DC Characteristics

The DC characteristics of the AMD Athlon processor are shown in Table 12. These values are defined at the card edge of the AMD Athlon processor module.

Table 12. DC Characteristics (Model 1)

Symbol	Parameter	Condition	Min	Max	Units	Notes
VCC_CORE	IO Supply Voltage		1.5	1.7	V	1
V _{REF}	DC Input Reference Voltage		(0.47*VCC_CORE) -50	(0.47*VCC_CORE) +50	mV	2
I _{VREF}	V _{REF} Input Pin Current	0 < V _{IN} < VCC_CORE	-250	+250	μA	3
V _{IH-DC}	DC Input High Voltage		V _{REF} + 325	VCC_CORE + 300	mV	
V _{IL-DC}	DC Input Low Voltage		-300	V _{REF} + 75	mV	
V _{IH-AC}	AC Input High Voltage		V _{REF} + 450	VCC_CORE + 500	mV	
V _{IL-AC}	AC Input Low Voltage		-500	V _{REF} - 50	mV	
V _{OH-DC}	DC Output High Voltage		VCC_CORE	VCC_CORE + 300	mV	4
V _{OL-DC}	DC Output Low Voltage	I _{OUT} = I _{OL-DC-MAX}	-300	+300	mV	4
V _{OH-AC}	AC Output High Voltage		VCC_CORE	VCC_CORE + 500	mV	4
V _{OL-AC}	AC Output Low Voltage		-500	400	mV	4
I _{OL-DC}	DC Output Current Low	V _{OUT} = V _{OL-DC-MAX}	-	33	mA	
I _{LEAK}	Tristate Leakage	0 < V _{IN} < VCC_CORE	-100	+100	μA	5
I _{IH}	Input High Current	V _{IN} =V _{IH-DC-MIN}	0	500	μA	

Notes:

- Nominal VCC_CORE is 1.6v.
- V_{REF}:
 - V_{REF} is nominally set by a (1%) resistor divider from VCC_CORE.
 - The suggested divider resistor values are 90.9 ohms over 80.6 ohms to produce a divisor of 0.47.
 - The internal V_{REF} (V_{REF-INT}) is the external V_{REF} scaled by 0.80 (V_{REF-INT} = (V_{REF}/0.80)). (Processor pin SysVrefMode = High)
 - Given: VCC_CORE = 1.6V, V_{REF} = 752mV (1.6 * 0.47), V_{REF-INT} = 940mV (752mV/0.8).
 - Peak-to-Peak AC noise on V_{REF} (AC) should not exceed 2% of V_{REF} (DC).
- I_{VREF} should be measured at nominal V_{REF}.
- V_{OL-DC-MAX}, V_{OL-AC-MAX}, V_{OH-DC-MIN} and V_{OH-AC-MIN} are specified at T = 100°C and VCC_CORE = 1.4V.
- Does not apply to V_{REF}.
- The following signals have twice the capacitance because they connect to two input pads—SDATAINCLK[3:0]# and SYSCLK, SYSCLK#. SDATAINCLK[3:0]# connects 2 byte clocks to form a word sized clock. SYSCLK connects to CLKIN/RSTCLK. SYSCLK# connects to CLKIN#/RSTCLK#.
- Measured at maximum VCC_CORE = 1.70 V—The maximum power supply current must be taken into account when designing a power supply.
- A minor process update to the existing 0.25-micron technology offers improved power performance for the AMD Athlon 700-MHz processor.

Table 12. DC Characteristics (Model 1) (continued)

Symbol	Parameter	Condition	Min	Max	Units	Notes
I_{IL}	Input Low Current	$V_{IN}=V_{IL-DC-MAX}$	0	500	μA	
C_{IN}	Input Pin Capacitance		4	12	pF	6
I_{CC}	Power Supply Current	500 MHz		27.4	A	7
		550 MHz		30.1	A	7
		600 MHz		32.9	A	7
		650 MHz		35.5	A	7
		700 MHz		33.1	A	7, 8

Notes:

- Nominal VCC_CORE is 1.6v.
- V_{REF} :
 - V_{REF} is nominally set by a (1%) resistor divider from VCC_CORE .
 - The suggested divider resistor values are 90.9 ohms over 80.6 ohms to produce a divisor of 0.47.
 - The internal V_{REF} ($V_{REF-INT}$) is the external V_{REF} scaled by 0.80 ($V_{REF-INT} = (V_{REF}/0.80)$). (Processor pin SysVrefMode = High)
 - Given: $VCC_CORE = 1.6V$, $V_{REF} = 752mV$ ($1.6 * 0.47$), $V_{REF-INT} = 940mV$ ($752mV/0.8$).
 - Peak-to-Peak AC noise on V_{REF} (AC) should not exceed 2% of V_{REF} (DC).
- I_{VREF} should be measured at nominal V_{REF} .
- $V_{OL-DC-MAX}$, $V_{OL-AC-MAX}$, $V_{OH-DC-MIN}$ and $V_{OH-AC-MIN}$ are specified at $T = 100^{\circ}C$ and $VCC_CORE = 1.4V$.
- Does not apply to V_{REF} .
- The following signals have twice the capacitance because they connect to two input pads— $SDATAINCLK[3:0]\#$ and $SYSCLK$, $SYSCLK\#$.
 $SDATAINCLK[3:0]\#$ connects 2 byte clocks to form a word sized clock. $SYSCLK$ connects to $CLKIN/RSTCLK$. $SYSCLK\#$ connects to $CLKIN\#/RSTCLK\#$.
- Measured at maximum $VCC_CORE = 1.70 V$ —The maximum power supply current must be taken into account when designing a power supply.
- A minor process update to the existing 0.25-micron technology offers improved power performance for the AMD Athlon 700-MHz processor.

6.11 AC Characteristics

The AC characteristics of the AMD Athlon processor are shown in Table 13. The parameters are grouped based on the source or destination of the signals involved. All parameters are defined at the card edge of the AMD Athlon processor module.

Table 13. AC Characteristics

Group	Symbol	Parameter	Min	Max	Units	Notes
All Signals	T_{RISE}	Output Rise Slew Rate	1	3	V/ns	1
	T_{FALL}	Output Fall Slew Rate	1	3	V/ns	1
Clock Forward	$T_{SKEW-SAMEEDGE}$	Output skew with respect to the same clock edge	–	385	ps	2
	$T_{SKEW-DIFFEDGE}$	Output skew with respect to a different clock edge	–	770	ps	2
	T_{SU}	Input Data Setup Time	300	–	ps	3
	T_{HD}	Input Data Hold Time	300	–	ps	3
Sync *4	T_{VAL}	RstClk to Output Valid	250	2000	ps	5
	T_{SU}	Setup to RstClk	500	–	ps	6
	T_{HD}	Hold from RstClk	1000	–	ps	6

Notes:

– Test Circuit used—See Figure 8 on page 33.

- Rise and fall time ranges are guidelines over which the I/O has been characterized.
- $T_{K7-SKEW-SAMEEDGE}$ is the maximum skew within a clock forwarded group between any two signals or between any signal and its forward clock, as measured at the package, with respect to the same clock edge.
 $T_{K7-SKEW-DIFFEDGE}$ is the maximum skew within a clock forwarded group between any two signals or between any signal and its forward clock, as measured at the package, with respect to different clock edges.
- Input SU and HD times are with respect to the appropriate Clock Forward Group input clock.
- The synchronous signals include PROCRDY, CONNECT, CLKFWDRST.
- T_{VAL} is RstClk rising edge to output valid for PROCRDY. Test Load—25pf.
- T_{SU} is setup of CONNECT/CLKFWDRST to rising edge of RSTCLK. T_{HD} is hold of CONNECT/CLKFWDRST from rising edge of RSTCLK.

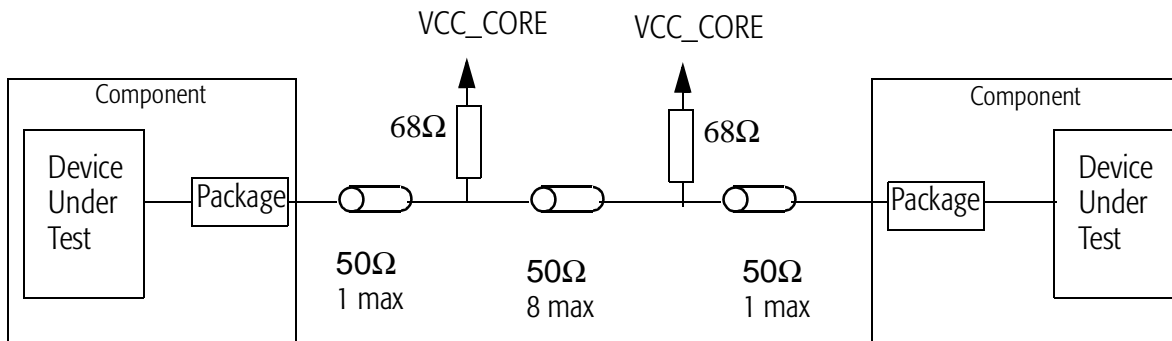

Figure 8. Test Circuit

7 Mechanical Data

7.1 Introduction

The AMD Athlon is a processor module comprised of a processor, L2 cache, passive components, a thermal plate, and a cover plate. The AMD Athlon processor connects to the motherboard through insertion into a connector known as Slot A.

7.2 Module Dimensions

Table 14 shows the dimensions of the AMD Athlon processor module.

Table 14. AMD Athlon™ Processor Module Dimensions

Description	Min	Max	Figure
Module Length	5.505 inches	5.515 inches	10 on page 37
Module Height	2.451 inches	2.483 inches	10
Module Depth	0.637 inch	0.657 inch	10
Thermal Plate Length	5.331 inches	5.351 inches	11 on page 38
Thermal Plate Height	1.917 inches	1.927 inches	11

Figures 10 through 14 starting on page 37 show the critical dimensions of the AMD Athlon processor module. All dimensions in the drawings are in inches and are not to scale. Table 15 lists the notes that pertain to the dimension drawings.

Table 15. Notes for Dimension Drawings

Note	Description
6	Area for part number and traceability information
7	Rivscrew attach hole. Maximum insertion depth: 0.269"
8	Heatsink clip attach hole. Maximum insertion depth: 0.233"
9	Thermal grease centered on SRAM pedestal

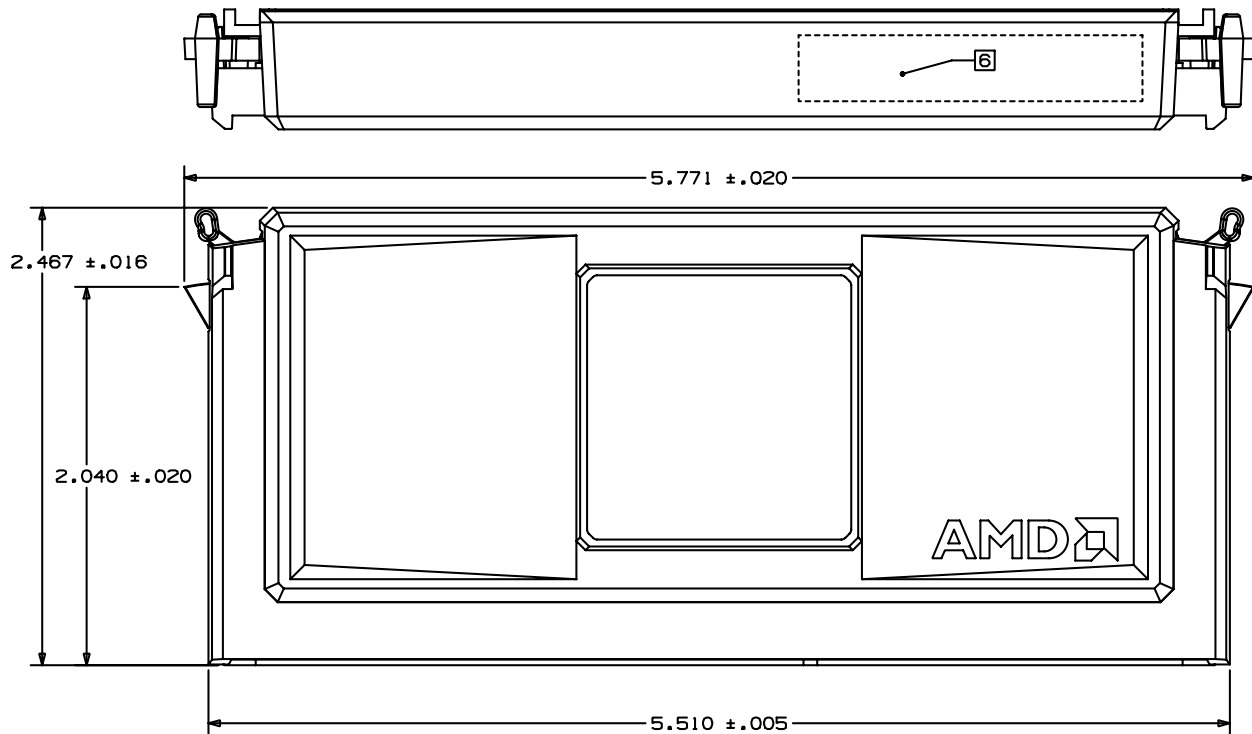

Figure 9. AMD Athlon™ Processor Module Dimensions—Front View

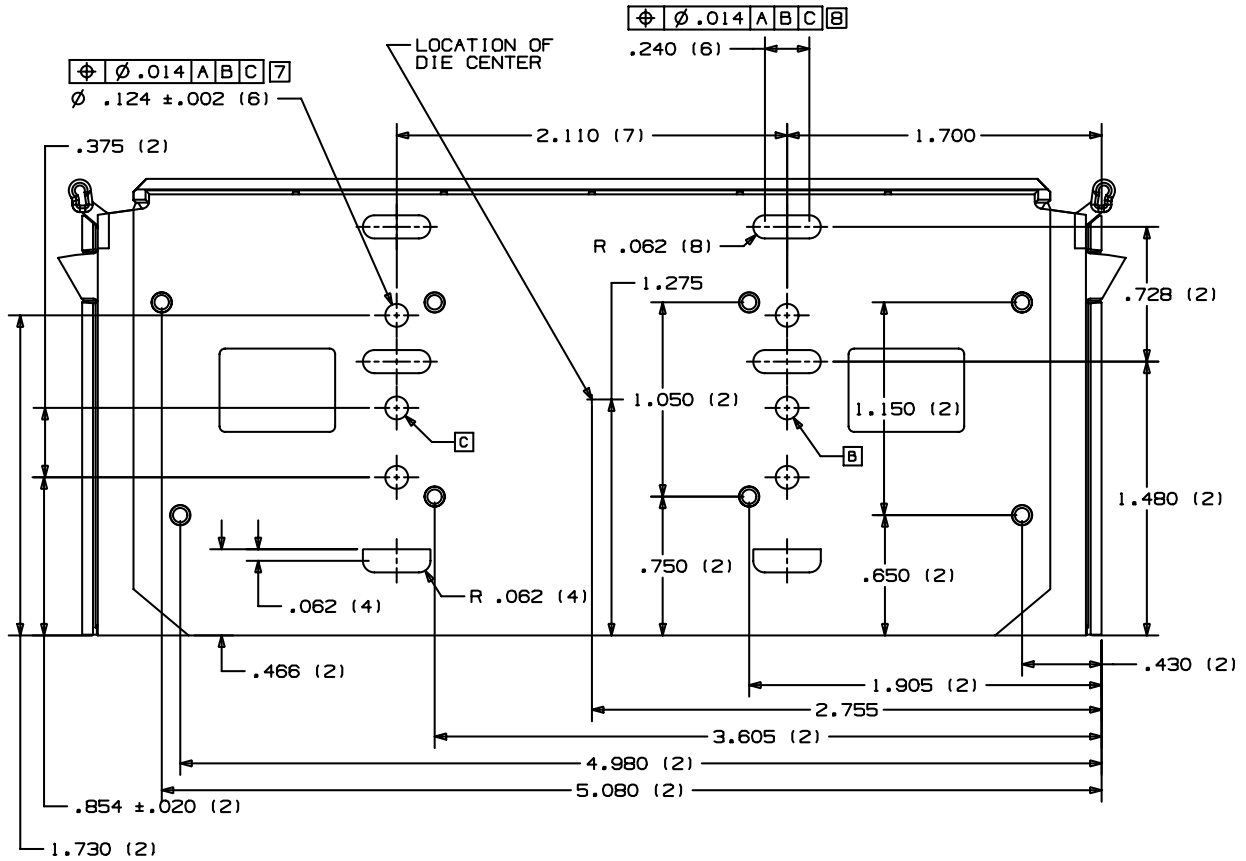

Figure 10. AMD Athlon™ Processor Module Dimensions—Plate Side View

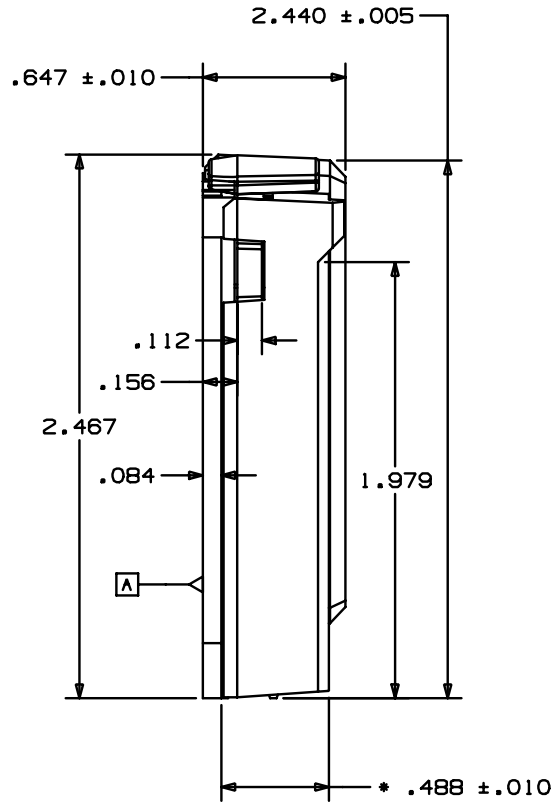

Figure 11. AMD Athlon™ Processor Module Dimensions—Side View

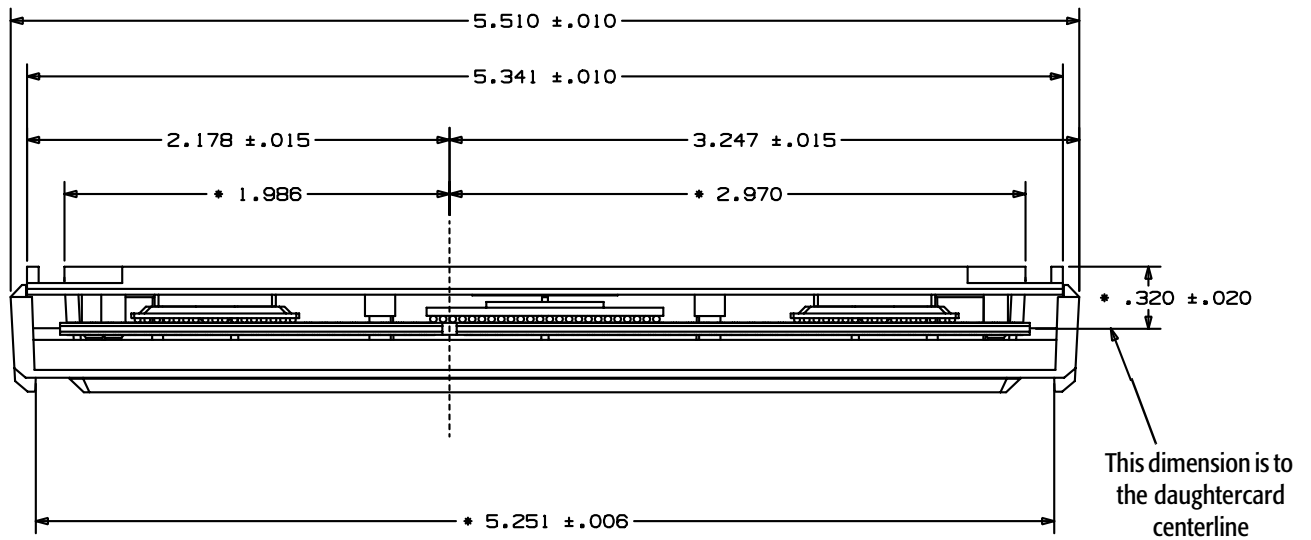

Figure 12. AMD Athlon™ Processor Module Dimensions—Edge View

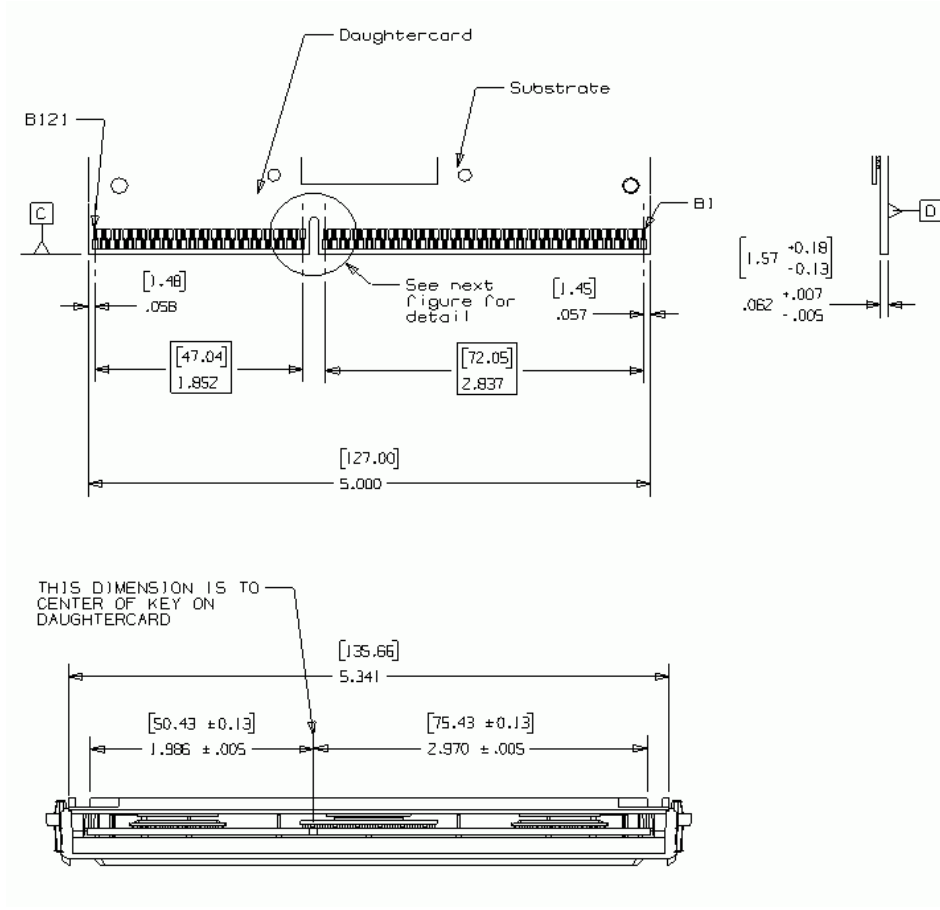

Figure 13. Card Edge Dimensions—Thermal Plate Side View

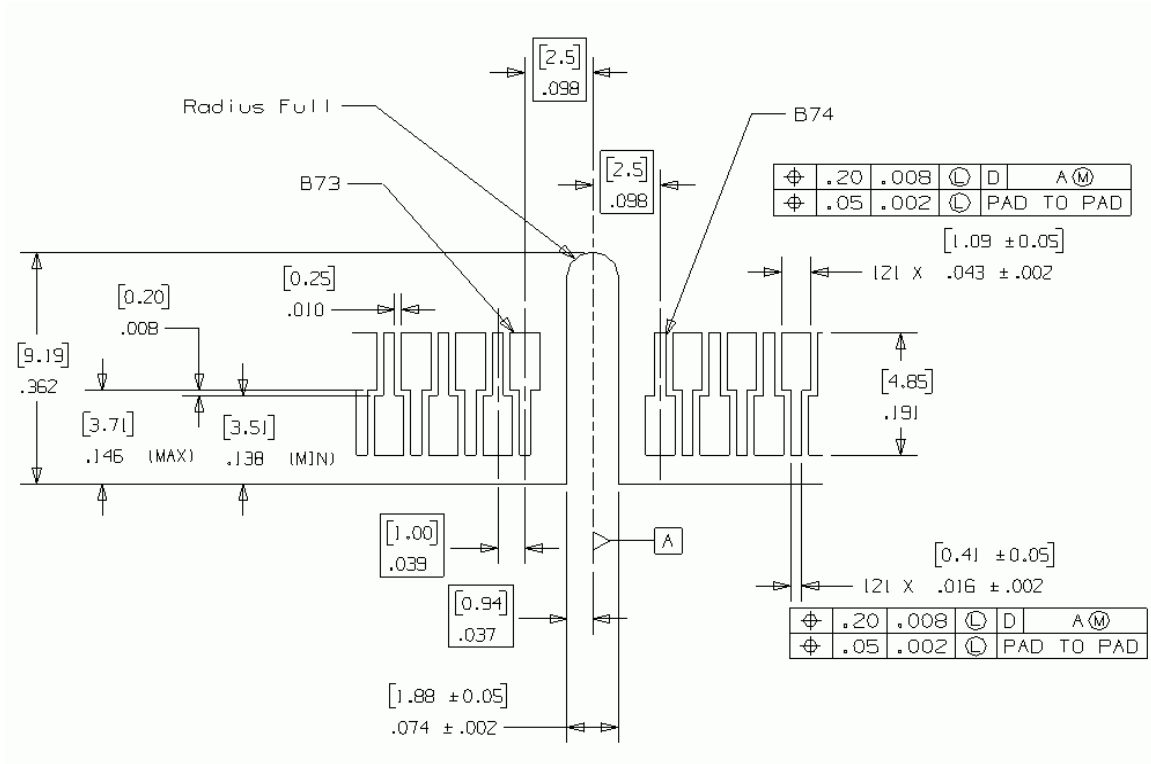

Figure 14. Card Edge Dimensions (Detail)

7.3 AMD Athlon™ Processor Card-Edge Signal Listing

Tables 16 through 18 shows the Slot A signals and pins ordered by pin number, pin name, and their physical position on the slot, respectively. The *High* and *Low* designation in the *Pin Name* column in Table 18 refers to the staggered high/low arrangement of the pins on the slot.

Table 16. AMD Athlon™ Processor Signals Ordered by Pin Number

Pin No.	Pin Name	Pin No.	Pin Name
A1	VCC2SEL	B1	SADDOUT[14]#
A2	VCC_SRAM[7]	B2	GND[10]
A3	Reserved	B3	SADDOUT[13]#
A4	VCC_SRAM[6]	B4	SADDOUT[7]#
A5	Reserved	B5	GND[51]
A6	VCC_SRAM[5]	B6	SADDOUTCLK#
A7	Reserved	B7	GND[7]
A8	VCC_SRAM[4]	B8	SADDOUT[12]#
A9	SMI#	B9	GND[21]
A10	VCC_SRAM[3]	B10	SADDOUT[9]#
A11	FERR	B11	SADDOUT[8]#
A12	INIT#	B12	GND[20]
A13	NMI	B13	SADDOUT[5]#
A14	VCC_SRAM[2]	B14	SADDOUT[6]#
A15	INTR	B15	GND[30]
A16	VCC_SRAM[1]	B16	SADDOUT[2]#
A17	RESET#	B17	GND[44]
A18	STPCLK#	B18	SADDOUT[3]#
A19	IGNNE#	B19	GND[19]
A20	VCC_SRAM[8]	B20	SDATAOUTCLK[3]#
A21	A20M#	B21	GND[40]
A22	VCC_CORE[41]	B22	SCHECK[6]#
A23	SADDOUT[10]#	B23	SDATA[53]#
A24	VCC_CORE[1]	B24	GND[8]
A25	SADDOUT[11]#	B25	SDATA[49]#
A26	VCC_CORE[19]	B26	SDATA[63]#
A27	SADDOUT[4]#	B27	GND[32]
A28	VCC_CORE[44]	B28	SDATAINCLK[3]#
A29	SDATA[55]#	B29	GND[3]
A30	VCC_CORE[10]	B30	SDATA[62]#
A31	SDATA[54]#	B31	GND[1]
A32	VCC_CORE[11]	B32	SDATA[60]#
A33	SDATA[52]#	B33	GND[13]
A34	VCC_CORE[35]	B34	SCHECK[7]#
A35	SDATA[61]#	B35	SDATA[59]#

Table 16. AMD Athlon™ Processor Signals Ordered by Pin Number (continued)

Pin No.	Pin Name	Pin No.	Pin Name
A36	VCC_CORE[25]	B36	GND[2]
A37	SDATA[50]#	B37	SDATA[58]#
A38	VCC_CORE[4]	B38	SDATA[57]#
A39	SDATA[51]#	B39	GND[16]
A40	VCC_CORE[26]	B40	SDATA[39]#
A41	SDATA[48]#	B41	GND[39]
A42	VCC_CORE[34]	B42	SDATA[56]#
A43	SDATA[36]#	B43	GND[38]
A44	VCC_CORE[16]	B44	SDATA[47]#
A45	SDATA[46]#	B45	SDATA[38]#
A46	VCC_CORE[38]	B46	GND[41]
A47	SDATA[37]#	B47	SDATA[45]#
A48	VCC_CORE[20]	B48	SDATA[44]#
A49	SDATA[35]#	B49	GND[37]
A50	VCC_CORE[30]	B50	SDATAINCLK[2]#
A51	SCHECK[4]#	B51	GND[34]
A52	VCC_CORE[3]	B52	SCHECK[5]#
A53	SDATA[34]#	B53	GND[33]
A54	VCC_CORE[31]	B54	SDATA[43]#
A55	SDATA[33]#	B55	SDATA[42]#
A56	VCC_CORE[29]	B56	GND[22]
A57	SDATA[32]#	B57	SDATA[41]#
A58	VCC_CORE[7]	B58	SDATA[40]#
A59	SDATAOUTCLK[2]#	B59	GND[50]
A60	VCC_CORE[18]	B60	SDATAOUTCLK[1]#
A61	SDATA[30]#	B61	GND[31]
A62	VCC_CORE[15]	B62	SDATA[22]#
A63	SDATA[31]#	B63	GND[35]
A64	VCC_CORE[14]	B64	SDATA[23]#
A65	SCHECK[3]#	B65	GND[36]
A66	VCC_CORE[33]	B66	SDATA[21]#
A67	SDATAINCLK[1]#	B67	GND[49]
A68	VCC_CORE[32]	B68	SDATA[20]#
A69	SDATA[29]#	B69	GND[14]
A70	SDATA[28]#	B70	SDATA[19]#
A71	VCC_CORE[9]	B71	SCHECK[2]#
A72	SDATA[26]#	B72	GND[9]
A73	SDATA[27]#	B73	SDATA[18]#
A74	VCC_CORE[42]	B74	SDATA[7]#
A75	SDATA[25]#	B75	GND[23]
A76	VCC_CORE[13]	B76	SDATA[17]#
A77	SDATA[24]#	B77	GND[15]
A78	VCC_CORE[27]	B78	SDATA[16]#
A79	SDATA[15]#	B79	GND[27]
A80	VCC_CORE[24]	B80	SDATA[6]#

Table 16. AMD Athlon™ Processor Signals Ordered by Pin Number (continued)

Pin No.	Pin Name	Pin No.	Pin Name
A81	SDATA[1]#	B81	SDATA[5]#
A82	VCC_CORE[2]	B82	GND[28]
A83	SDATA[12]#	B83	SCHECK[0]#
A84	VCC_CORE[23]	B84	SDATA[4]#
A85	SCHECK[1]#	B85	GND[29]
A86	VCC_CORE[5]	B86	SDATA[2]#
A87	SDATA[8]#	B87	GND[25]
A88	VCC_CORE[39]	B88	SDATAINCLK[0]#
A89	SDATA[10]#	B89	GND[26]
A90	VCC_CORE[22]	B90	SDATA[3]#
A91	SDATAOUTCLK[0]#	B91	GND[6]
A92	VCC_CORE[21]	B92	SDATA[0]#
A93	SADDIN[7]#	B93	GND[5]
A94	VCC_CORE[40]	B94	SDATA[13]#
A95	SADDIN[6]#	B95	SDATA[14]#
A96	VCC_CORE[37]	B96	GND[4]
A97	SADDIN[8]#	B97	SDATA[11]#
A98	VCC_CORE[6]	B98	SDATA[9]#
A99	SDATAOUTVAL#	B99	GND[17]
A100	VCC_CORE[28]	B100	SADDIN[5]#
A101	SDATAINVAL#	B101	GND[18]
A102	VCC_CORE[36]	B102	SADDIN[11]#
A103	CONNECT	B103	GND[45]
A104	VCC_CORE[12]	B104	SADDIN[2]#
A105	CLKFWRDST	B105	GND[48]
A106	PROCRDY	B106	SADDIN[3]#
A107	VCC_CORE[43]	B107	SADDIN[4]#
A108	SYSCLK#	B108	GND[46]
A109	SYSCLK	B109	SADDIN[10]#
A110	VCC_CORE[17]	B110	SADDIN[9]#
A111	PWROK	B111	GND[43]
A112	VID[0]	B112	SADDIN[13]#
A113	VID[1]	B113	GND[42]
A114	VID[2]	B114	SADDINCLK#
A115	VID[3]	B115	GND[11]
A116	FID[3]	B116	SADDIN[14]#
A117	FID[2]	B117	GND[12]
A118	FID[1]	B118	SFILLVAL#
A119	FID[0]	B119	GND[47]
A120	COREFB+	B120	SADDIN[12]#
A121	COREFB-	B121	GND[24]

Table 17. AMD Athlon™ Processor Signals Ordered by Pin Name

Pin Name	Pin No.	Pin Name	Pin No.
A20M#	A21	GND[25]	B87
CLKFWRST	A105	GND[26]	B89
CONNECT	A103	GND[27]	B79
COREFB+	A120	GND[28]	B82
COREFB-	A121	GND[29]	B85
FERR	A11	GND[30]	B15
FID[0]	A119	GND[31]	B61
FID[1]	A118	GND[32]	B27
FID[2]	A117	GND[33]	B53
FID[3]	A116	GND[34]	B51
GND[1]	B31	GND[35]	B63
GND[2]	B36	GND[36]	B65
GND[3]	B29	GND[37]	B49
GND[4]	B96	GND[38]	B43
GND[5]	B93	GND[39]	B41
GND[6]	B91	GND[40]	B21
GND[7]	B7	GND[41]	B46
GND[8]	B24	GND[42]	B113
GND[9]	B72	GND[43]	B111
GND[10]	B2	GND[44]	B17
GND[11]	B115	GND[45]	B103
GND[12]	B117	GND[46]	B108
GND[13]	B33	GND[47]	B119
GND[14]	B69	GND[48]	B105
GND[15]	B77	GND[49]	B67
GND[16]	B39	GND[50]	B59
GND[17]	B99	GND[51]	B5
GND[18]	B101	IGNNE#	A19
GND[19]	B19	INIT#	A12
GND[20]	B12	INTR	A15
GND[21]	B9	NMI	A13
GND[22]	B56	Reserved	A3
GND[23]	B75	Reserved	A5
GND[24]	B121	Reserved	A7
PROCRDY	A106	SCHECK[3]#	A65
PWROK	A111	SCHECK[4]#	A51
RESET#	A17	SCHECK[5]#	B52
SADDIN[2]#	B104	SCHECK[6]#	B22
SADDIN[3]#	B106	SCHECK[7]#	B34
SADDIN[4]#	B107	SDATA[0]#	B92
SADDIN[5]#	B100	SDATA[1]#	A81
SADDIN[6]#	A95	SDATA[2]#	B86
SADDIN[7]#	A93	SDATA[3]#	B90
SADDIN[8]#	A97	SDATA[4]#	B84
SADDIN[9]#	B110	SDATA[5]#	B81

Table 17. AMD Athlon™ Processor Signals Ordered by Pin Name (continued)

Pin Name	Pin No.	Pin Name	Pin No.
SADDIN[10]#	B109	SDATA[6]#	B80
SADDIN[11]#	B102	SDATA[7]#	B74
SADDIN[12]#	B120	SDATA[8]#	A87
SADDIN[13]#	B112	SDATA[9]#	B98
SADDIN[14]#	B116	SDATA[10]#	A89
SADDINCLK#	B114	SDATA[11]#	B97
SADDOUT[2]#	B16	SDATA[12]#	A83
SADDOUT[3]#	B18	SDATA[13]#	B94
SADDOUT[4]#	A27	SDATA[14]#	B95
SADDOUT[5]#	B13	SDATA[15]#	A79
SADDOUT[6]#	B14	SDATA[16]#	B78
SADDOUT[7]#	B4	SDATA[17]#	B76
SADDOUT[8]#	B11	SDATA[18]#	B73
SADDOUT[9]#	B10	SDATA[19]#	B70
SADDOUT[10]#	A23	SDATA[20]#	B68
SADDOUT[11]#	A25	SDATA[21]#	B66
SADDOUT[12]#	B8	SDATA[22]#	B62
SADDOUT[13]#	B3	SDATA[23]#	B64
SADDOUT[14]#	B1	SDATA[24]#	A77
SADDOUTCLK#	B6	SDATA[25]#	A75
SCHECK[0]#	B83	SDATA[26]#	A72
SCHECK[1]#	A85	SDATA[27]#	A73
SCHECK[2]#	B71	SDATA[28]#	A70
SDATA[29]#	A69	SDATA[63]#	B26
SDATA[30]#	A61	SDATAINCLK[0]#	B88
SDATA[31]#	A63	SDATAINCLK[1]#	A67
SDATA[32]#	A57	SDATAINCLK[2]#	B50
SDATA[33]#	A55	SDATAINCLK[3]#	B28
SDATA[34]#	A53	SDATAINVAL#	A101
SDATA[35]#	A49	SDATAOUTCLK[0]#	A91
SDATA[36]#	A43	SDATAOUTCLK[1]#	B60
SDATA[37]#	A47	SDATAOUTCLK[2]#	A59
SDATA[38]#	B45	SDATAOUTCLK[3]#	B20
SDATA[39]#	B40	SDATAOUTVAL#	A99
SDATA[40]#	B58	SFILLVAL#	B118
SDATA[41]#	B57	SMI#	A9
SDATA[42]#	B55	STPCLK#	A18
SDATA[43]#	B54	SYSCLK	A109
SDATA[44]#	B48	SYSCLK#	A108
SDATA[45]#	B47	VCC2SEL	A1
SDATA[46]#	A45	VCC_CORE[1]	A24
SDATA[47]#	B44	VCC_CORE[2]	A82
SDATA[48]#	A41	VCC_CORE[3]	A52
SDATA[49]#	B25	VCC_CORE[4]	A38
SDATA[50]#	A37	VCC_CORE[5]	A86

Table 17. AMD Athlon™ Processor Signals Ordered by Pin Name (continued)

Pin Name	Pin No.	Pin Name	Pin No.
SDATA[51]#	A39	VCC_CORE[6]	A98
SDATA[52]#	A33	VCC_CORE[7]	A58
SDATA[53]#	B23	VCC_CORE[9]	A71
SDATA[54]#	A31	VCC_CORE[10]	A30
SDATA[55]#	A29	VCC_CORE[11]	A32
SDATA[56]#	B42	VCC_CORE[12]	A104
SDATA[57]#	B38	VCC_CORE[13]	A76
SDATA[58]#	B37	VCC_CORE[14]	A64
SDATA[59]#	B35	VCC_CORE[15]	A62
SDATA[60]#	B32	VCC_CORE[16]	A44
SDATA[61]#	A35	VCC_CORE[17]	A110
SDATA[62]#	B30	VCC_CORE[18]	A60
VCC_CORE[19]	A26	VCC_CORE[38]	A46
VCC_CORE[20]	A48	VCC_CORE[39]	A88
VCC_CORE[21]	A92	VCC_CORE[40]	A94
VCC_CORE[22]	A90	VCC_CORE[41]	A22
VCC_CORE[23]	A84	VCC_CORE[42]	A74
VCC_CORE[24]	A80	VCC_CORE[43]	A107
VCC_CORE[25]	A36	VCC_CORE[44]	A28
VCC_CORE[26]	A40	VCC_SRAM[1]	A16
VCC_CORE[27]	A78	VCC_SRAM[2]	A14
VCC_CORE[28]	A100	VCC_SRAM[3]	A10
VCC_CORE[29]	A56	VCC_SRAM[4]	A8
VCC_CORE[30]	A50	VCC_SRAM[5]	A6
VCC_CORE[31]	A54	VCC_SRAM[6]	A4
VCC_CORE[32]	A68	VCC_SRAM[7]	A2
VCC_CORE[33]	A66	VCC_SRAM[8]	A20
VCC_CORE[34]	A42	VID[0]	A112
VCC_CORE[35]	A34	VID[1]	A113
VCC_CORE[36]	A102	VID[2]	A114
VCC_CORE[37]	A96	VID[3]	A115

Table 18. AMD Athlon™ Processor Signals Ordered by Physical Location

Pin No.	Pin Name—High	Pin Name—Low	Pin No.	Pin No.	Pin Name—High	Pin Name—Low	Pin No.
A121	COREFB-	COREFB+	A120	B121	GND[24]	SADDIN[12]#	B120
A119	FID[0]	FID[1]	A118	B119	GND[47]	SFILLVAL#	B118
A117	FID[2]	FID[3]	A116	B117	GND[12]	SADDIN[14]#	B116
A115	VID[3]	VID[2]	A114	B115	GND[11]	SADDINCLK#	B114
A113	VID[1]	VID[0]	A112	B113	GND[42]	SADDIN[13]#	B112
A111	PWROK	VCC_CORE[17]	A110	B111	GND[43]	SADDIN[9]#	B110
A109	SYSCLK	SYSCLK#	A108	B109	SADDIN[10]#	GND[46]	B108
A107	VCC_CORE[43]	PROCRDY	A106	B107	SADDIN[4]#	SADDIN[3]#	B106
A105	CLKFWRDST	VCC_CORE[12]	A104	B105	GND[48]	SADDIN[2]#	B104
A103	CONNECT	VCC_CORE[36]	A102	B103	GND[45]	SADDIN[11]#	B102
A101	SDATAINVAL#	VCC_CORE[28]	A100	B101	GND[18]	SADDIN[5]#	B100
A99	SDATAOUTVAL#	VCC_CORE[6]	A98	B99	GND[17]	SDATA[9]#	B98
A97	SADDIN[8]#	VCC_CORE[37]	A96	B97	SDATA[11]#	GND[4]	B96
A95	SADDIN[6]#	VCC_CORE[40]	A94	B95	SDATA[14]#	SDATA[13]#	B94
A93	SADDIN[7]#	VCC_CORE[21]	A92	B93	GND[5]	SDATA[0]#	B92
A91	SDATAOUTCLK[0]#	VCC_CORE[22]	A90	B91	GND[6]	SDATA[3]#	B90
A89	SDATA[10]#	VCC_CORE[39]	A88	B89	GND[26]	SDATAINCLK[0]#	B88
A87	SDATA[8]#	VCC_CORE[5]	A86	B87	GND[25]	SDATA[2]#	B86
A85	SCHECK[1]#	VCC_CORE[23]	A84	B85	GND[29]	SDATA[4]#	B84
A83	SDATA[12]#	VCC_CORE[2]	A82	B83	SCHECK[0]#	GND[28]	B82
A81	SDATA[1]#	VCC_CORE[24]	A80	B81	SDATA[5]#	SDATA[6]#	B80
A79	SDATA[15]#	VCC_CORE[27]	A78	B79	GND[27]	SDATA[16]#	B78
A77	SDATA[24]#	VCC_CORE[13]	A76	B77	GND[15]	SDATA[17]#	B76
A75	SDATA[25]#	VCC_CORE[42]	A74	B75	GND[23]	SDATA[7]#	B74
A73	SDATA[27]#	SDATA[26]#	A72	B73	SDATA[18]#	GND[9]	B72
A71	VCC_CORE[9]	SDATA[28]#	A70	B71	SCHECK[2]#	SDATA[19]#	B70
A69	SDATA[29]#	VCC_CORE[32]	A68	B69	GND[14]	SDATA[20]#	B68
A67	SDATAINCLK[1]#	VCC_CORE[33]	A66	B67	GND[49]	SDATA[21]#	B66
A65	SCHECK[3]#	VCC_CORE[14]	A64	B65	GND[36]	SDATA[23]#	B64
A63	SDATA[31]#	VCC_CORE[15]	A62	B63	GND[35]	SDATA[22]#	B62
A61	SDATA[30]#	VCC_CORE[18]	A60	B61	GND[31]	SDATAOUTCLK[1]#	B60
A59	SDATAOUTCLK[2]#	VCC_CORE[7]	A58	B59	GND[50]	SDATA[40]#	B58
A57	SDATA[32]#	VCC_CORE[29]	A56	B57	SDATA[41]#	GND[22]	B56
A55	SDATA[33]#	VCC_CORE[31]	A54	B55	SDATA[42]#	SDATA[43]#	B54
A53	SDATA[34]#	VCC_CORE[3]	A52	B53	GND[33]	SCHECK[5]#	B52
A51	SCHECK[4]#	VCC_CORE[30]	A50	B51	GND[34]	SDATAINCLK[2]#	B50
A49	SDATA[35]#	VCC_CORE[20]	A48	B49	GND[37]	SDATA[44]#	B48
A47	SDATA[37]#	VCC_CORE[38]	A46	B47	SDATA[45]#	GND[41]	B46
A45	SDATA[46]#	VCC_CORE[16]	A44	B45	SDATA[38]#	SDATA[47]#	B44
A43	SDATA[36]#	VCC_CORE[34]	A42	B43	GND[38]	SDATA[56]#	B42
A41	SDATA[48]#	VCC_CORE[26]	A40	B41	GND[39]	SDATA[39]#	B40
A39	SDATA[51]#	VCC_CORE[4]	A38	B39	GND[16]	SDATA[57]#	B38
A37	SDATA[50]#	VCC_CORE[25]	A36	B37	SDATA[58]#	GND[2]	B36
A35	SDATA[61]#	VCC_CORE[35]	A34	B35	SDATA[59]#	SCHECK[7]#	B34
A33	SDATA[52]#	VCC_CORE[11]	A32	B33	GND[13]	SDATA[60]#	B32
A31	SDATA[54]#	VCC_CORE[10]	A30	B31	GND[1]	SDATA[62]#	B30
A29	SDATA[55]#	VCC_CORE[44]	A28	B29	GND[3]	SDATAINCLK[3]#	B28
A27	SADDOUT[4]#	VCC_CORE[19]	A26	B27	GND[32]	SDATA[63]#	B26
A25	SADDOUT[11]#	VCC_CORE[1]	A24	B25	SDATA[49]#	GND[8]	B24
A23	SADDOUT[10]#	VCC_CORE[41]	A22	B23	SDATA[53]#	SCHECK[6]#	B22
A21	A20M#	VCC_SRAM[8]	A20	B21	GND[40]	SDATAOUTCLK[3]#	B20
A19	IGNNE#	STPCLK#	A18	B19	GND[19]	SADDOUT[3]#	B18
A17	RESET#	VCC_SRAM[1]	A16	B17	GND[44]	SADDOUT[2]#	B16
A15	INTR	VCC_SRAM[2]	A14	B15	GND[30]	SADDOUT[6]#	B14
A13	NMI	INIT#	A12	B13	SADDOUT[5]#	GND[20]	B12
A11	FERR#	VCC_SRAM[3]	A10	B11	SADDOUT[8]#	SADDOUT[9]#	B10
A9	SMI#	VCC_SRAM[4]	A8	B9	GND[21]	SADDOUT[12]#	B8
A7	Reserved	VCC_SRAM[5]	A6	B7	GND[7]	SADDOUTCLK#	B6
A5	Reserved	VCC_SRAM[6]	A4	B5	GND[51]	SADDOUT[7]#	B4
A3	Reserved	VCC_SRAM[7]	A2	B3	SADDOUT[13]#	GND[10]	B2
A1	VCC2SEL			B1	SADDOUT[14]#		

8 Ordering Information

Standard AMD Athlon™ Processor Products

AMD standard products are available in several operating ranges. The ordering part number (OPN) is formed by a combination of the elements below.

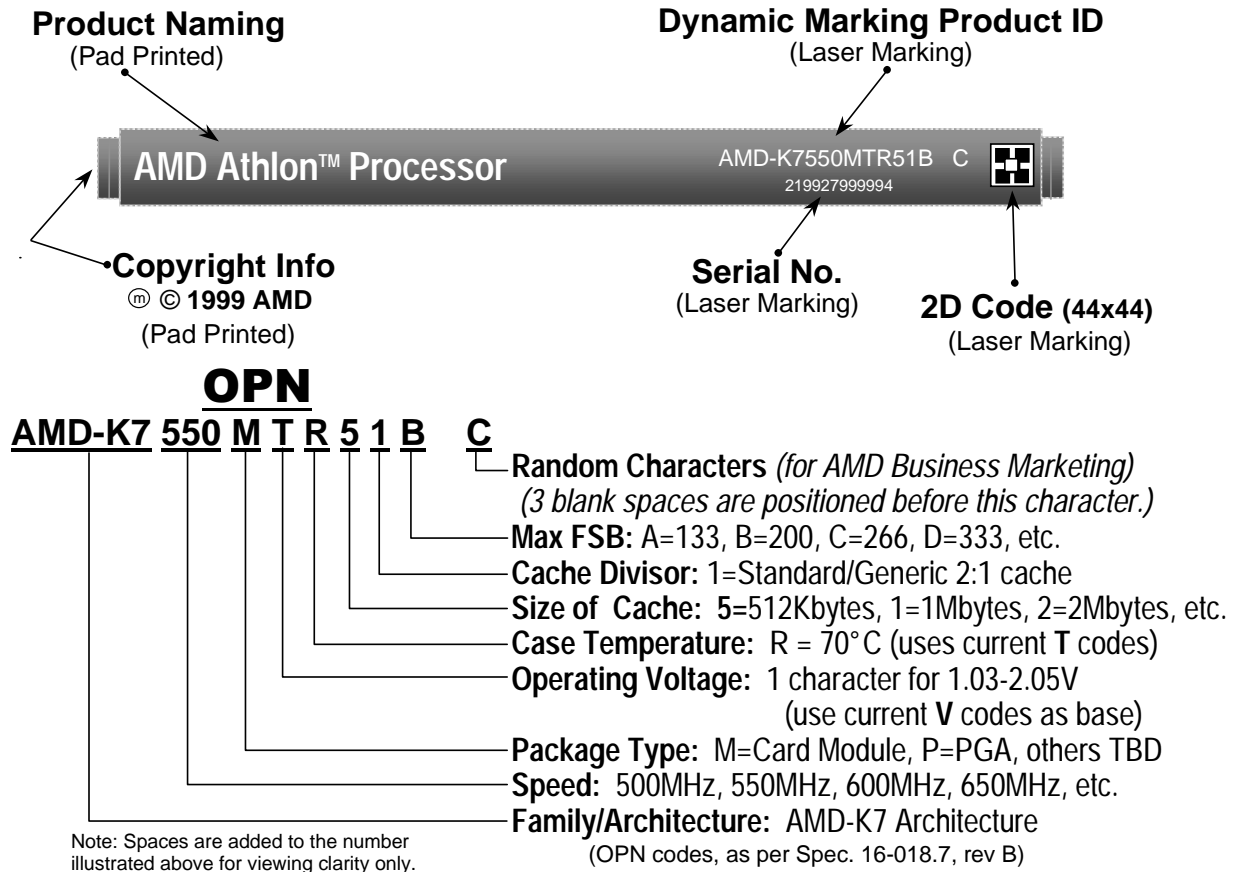

Table 19. Valid Ordering Part Number Combinations

OPN	Package Type	Operating Voltage	Plate Temperature
AMD-K7500MTR51B C	Card Module	1.55V–1.65V	0°C–70°C
AMD-K7550MTR51B C	Card Module	1.55V–1.65V	0°C–70°C
AMD-K7600MTR51B C	Card Module	1.55V–1.65V	0°C–70°C
AMD-K7650MTR51B C	Card Module	1.55V–1.65V	0°C–70°C
AMD-K7700MTR51B C	Card Module	1.55V–1.65V	0°C–70°C

Notes:
This table lists configurations planned to be supported in volume for this device. Consult the local AMD sales office to confirm availability of specific valid combinations and to check on newly-released combinations.

Part Two

AMD Athlon™ Processor Model 2

The AMD Athlon processor data sheet supports the Model 1 and Model 2 versions of the AMD Athlon processor family. Model 1 refers to the AMD Athlon processor manufactured with 0.25-micron process technology and Model 2 refers to the AMD Athlon manufactured with 0.18-micron process technology. Part Two (chapters 9–16) contains information regarding new specifications and differences that pertain only to Model 2 as compared to Model 1. For information about Model 1, see Part One, “AMD Athlon™ Processor Family” on page 3.

9 Overview

The AMD Athlon™ processor powers the next generation in computing platforms, delivering the ultimate performance for cutting-edge applications and an unprecedented computing experience.

AMD continues to deliver leading-edge processor solutions by advancing the highly acclaimed AMD Athlon processor with state-of-the-art 0.18-micron technology. The AMD-developed 0.18-micron technology enables the AMD Athlon processor to deliver higher performance with lower power dissipation.

The AMD Athlon processor is the world's most powerful x86 processor, delivering the highest integer, floating-point and 3D multimedia performance for applications running on x86 system platforms. The AMD Athlon processor provides industry-leading processing power for cutting-edge software applications, including digital content creation, digital photo editing, digital video, image compression, video encoding for streaming over the internet, soft DVD, commercial 3D modeling, workstation-class computer-aided design (CAD), commercial desktop publishing, and speech recognition. It also offers the scalability and 'peace-of-mind' reliability that IT managers and business users require for enterprise computing.

The AMD Athlon processor features the industry's first seventh-generation x86 microarchitecture, which is designed to support the growing processor and system bandwidth requirements of emerging software, graphics, I/O, and memory technologies. The AMD Athlon processor's high-speed execution core includes multiple x86 instruction decoders, a dual-ported 128-Kbyte split level-one (L1) cache, three independent integer pipelines, three address calculation pipelines, and the x86 industry's first superscalar, fully pipelined, out-of-order, three-way floating-point engine. The floating-point engine is capable of delivering 2.4 gigaflops (Gflops) of single-precision and more than 1 Gflop of double-precision floating-point results at 600 MHz, for superior performance on numerically complex applications.

The AMD Athlon processor microarchitecture incorporates enhanced 3DNow!™ technology, a high-performance cache architecture, and a 200-MHz, 1.6-Gigabyte per second system bus—the first bus of its kind for x86 system platforms. Based on

the Alpha™ EV6 interface protocol licensed from Digital Equipment Corporation, the AMD Athlon system bus combines the latest technological advances, such as point-to-point topology, source-synchronous packet-based transfers, and low-voltage signaling, to provide the most powerful, scalable bus available for any x86 processor.

The AMD Athlon processor is binary-compatible with existing x86 software and backwards compatible with applications optimized for MMX™ and 3DNow! instructions. Using a data format and single-instruction multiple-data (SIMD) operations based on the MMX instruction model, the AMD Athlon processor can produce as many as four, 32-bit, single-precision floating-point results per clock cycle, potentially resulting in 2.4 Gflops at 600 MHz (fully scalable). The enhanced 3DNow! technology implemented in the AMD Athlon processor includes new integer multimedia instructions and software-directed data movement instructions for optimizing such applications as digital content creation and streaming video for the internet, as well as new instructions for digital signal processing (DSP)/communications applications.

9.1 AMD Athlon™ Processor Microarchitecture Summary

The following features summarize the AMD Athlon processor microarchitecture:

- The industry's first nine-issue, superpipelined, superscalar x86 processor microarchitecture designed for high clock frequencies
- Multiple x86 instruction decoders
- Three out-of-order, superscalar, fully pipelined floating-point execution units, which execute all x87 (floating-point), MMX and 3DNow! instructions
- Three out-of-order, superscalar, pipelined integer units
- Three out-of-order, superscalar, pipelined address calculation units
- 72-entry instruction control unit
- Advanced dynamic branch prediction
- Enhanced 3DNow! technology with new instructions to enable improved integer math calculations for speech or video encoding and improved data movement for internet plug-ins and other streaming applications

- 200-MHz AMD Athlon system bus (scalable beyond 400 MHz) enabling leading-edge system bandwidth for data movement-intensive applications
- High-performance cache architecture featuring an integrated 128-Kbyte L1 cache and a programmable, high-speed backside L2 cache interface

The AMD Athlon processor delivers superior system performance in a cost-effective, industry-standard form factor. The AMD Athlon processor is compatible with motherboards based on AMD's Slot A connector (mechanically compatible with the existing SC242 infrastructure), which leverages commonly available chassis, power supply, and thermal solutions. Figure 15 shows a typical AMD Athlon processor system block diagram.

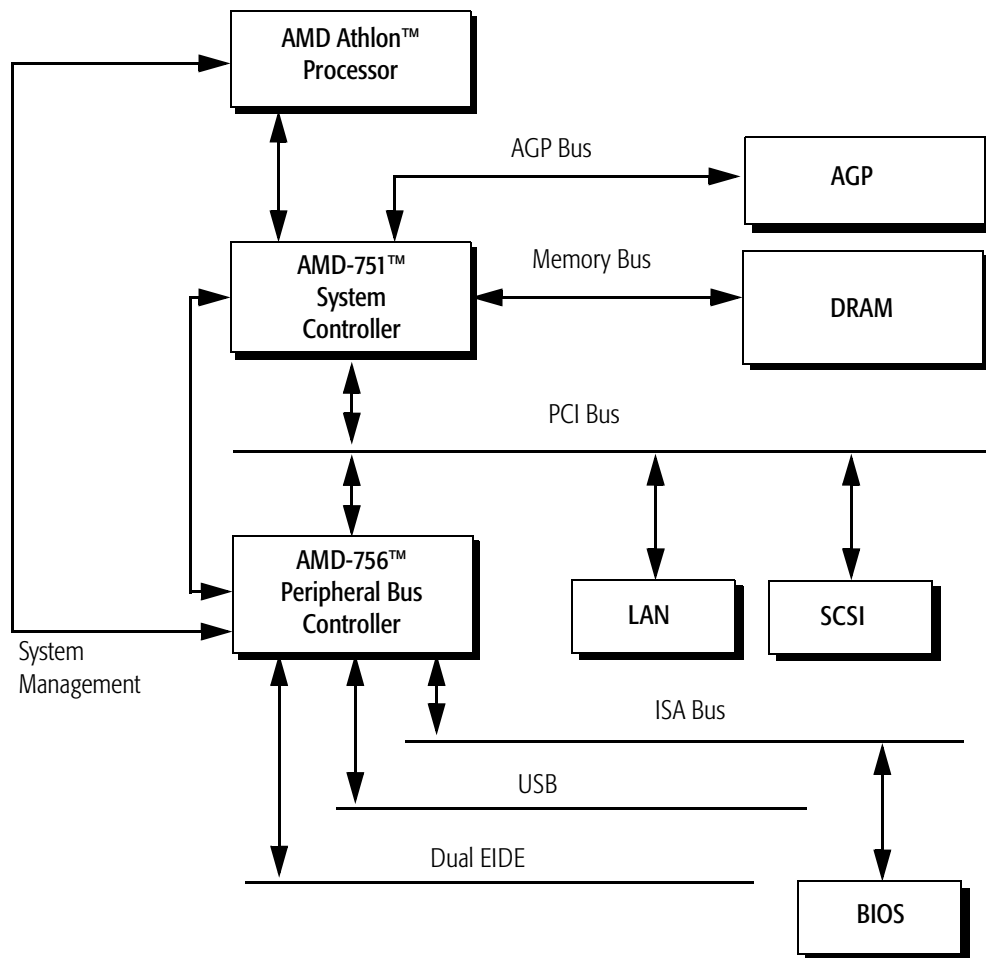

Figure 15. Typical AMD Athlon™ Processor System Block Diagram

10 Interface Signals

10.1 Overview

The AMD Athlon system bus architecture is designed to deliver unprecedented data movement bandwidth for next-generation x86 platforms, as well as the high performance required by enterprise-class application software. The system bus architecture consists of three high-speed channels (a unidirectional processor request channel, a unidirectional probe channel, and a 72-bit bidirectional data channel, including 8-bit error code correction [ECC] protection), source-synchronous clocking, and a packet-based protocol. In addition, the system bus supports several control, clock, and legacy signals. The interface signals use a HSTL-like, low-voltage swing signaling technology contained within the Slot A mechanical connector, which is mechanically compatible with the industry-standard SC242 connector.

10.2 Signaling Technology

The AMD Athlon processor Model 2 uses the same signaling technology as the AMD Athlon processor Model 1. For information about the bus signaling technology for the AMD Athlon processor Model 2, see Chapter 2, “Interface Signals” on page 5.

10.3 AMD Athlon™ System Bus Signals

Table 21 on page 58 shows the AMD Athlon system bus signals and legacy interface signals. The difference between the AMD Athlon Model 2 and Model 1 processors with respect to legacy interface signals is the addition of the industry-standard APIC signals, PICCLK and PICD[1:0]#. Table 20 on page 58 shows the pin-type definitions used in the *Type* column of Table 21.

Table 20. Pin-Type Definitions

Mnemonic	Definition
I	Standard input pin to the processor
O	Standard output pin from the processor
I/O	Bidirectional, three-state input/output pin
OD	Open-drain structure that allows multiple devices to share the pin in a wired-OR configuration
PP	Push/Pull structure driven by a single source
V _{CCCORE}	AMD Athlon processor core voltage

Table 21. AMD Athlon™ System Bus and Legacy Interface Signals

Signal Name	Type	Level	Number of Pins	Description
A20M#	I	OD V _{CCCORE}	1	A20M# is an input from the system used to simulate address wrapping around in the 20-bit 8086.
CLKFWRST	I	OD V _{CCCORE}	1	CLKFWRST resets clock-forward circuitry for both the system and processor.
CONNECT	I	OD V _{CCCORE}	1	CONNECT is an input from the system used for power management and clock-forward initialization at reset.
COREFB+ COREFB-	O	PP V _{CCCORE}	2	COREFB+ and COREFB- are outputs to the system that provide AMD Athlon processor core voltage feedback to the system.
FERR	O	OD V _{CCCORE}	1	FERR is an output to the system that is asserted for any unmasked numerical exception independent of the NE bit in CR0.
FID[3:0]	O	OD V _{CCCORE}	4	The FID[3:0] signals are outputs to the system that report the multiplier used on the system clock (SYSCLK) producing the AMD Athlon processor core clock.
IGNNE#	I	OD V _{CCCORE}	1	IGNNE# is an input from the system that tells the processor to ignore numeric errors.
INIT#	I	OD V _{CCCORE}	1	INIT# is an input from the system that resets the integer registers without affecting the floating-point registers or the internal caches. Execution starts at 0FFFF FFF0h.
INTR	I	OD V _{CCCORE}	1	INTR is an input from the system that causes the processor to start an interrupt acknowledge transaction that fetches the 8-bit interrupt vector and starts execution at that location.
NMI	I	OD V _{CCCORE}	1	NMI is an input from the system that causes a non-maskable interrupt.
PICCLK	I	PP V _{CCCORE}	1	PICCLK is an input clock that is required for operation of the APIC bus.

Table 21. AMD Athlon™ System Bus and Legacy Interface Signals (continued)

Signal Name	Type	Level	Number of Pins	Description
PICD[1:0]#	I	OD V _{CC} CORE	2	PICD[1:0]# are bidirectional signals that are used by the APIC bus, and must be connected to all APIC data pins on all devices of the APIC bus.
PROCRDY	O	OD V _{CC} CORE	1	PROCRDY is an output to the system and is used for power management and source-synchronous clock initialization at reset.
PWROK	I	OD V _{CC} CORE	1	PWROK is an input from the system indicating that the core power is within specified limits.
RESET#	I	OD V _{CC} CORE	1	RESET# is an input from the system that initializes and resets the processor and invalidates cache blocks.
SADDIN[14:2]#	I	OD V _{CC} CORE	13	SADDIN[14:2]# is the unidirectional system probe and data movement command channel from the system.
SADDINCLK#	I	OD V _{CC} CORE	1	SADDINCLK# is the single-ended source-synchronous clock for SADDIN[14:2]# and is driven by the system.
SADDOUT[14:2]#	O	OD V _{CC} CORE	13	SADDOUT[14:2]# is the unidirectional processor request channel to the system. It is used to transfer processor requests or probe responses to the system.
SADDOUTCLK#	O	OD V _{CC} CORE	1	SADDOUTCLK# is the single-ended source-synchronous clock for SADDOUT[14:2]# driven by the processor.
SCHECK[7:0]#	I/O	OD V _{CC} CORE	8	SCHECK[7:0]# contain the ECC bits for data transfers on SDATA[63:0]#.
SDATA[63:0]#	I/O	OD V _{CC} CORE	64	SDATA[63:0]# is the bidirectional channel between the processor and system for data movement.
SDATAINCLK[3:0]#	I	OD V _{CC} CORE	4	SDATAINCLK[3:0]# is the single-ended forwarded clock driven by the system to transfer data on SDATA[63:0]#. Each 16-bit data word is skewed-aligned with this clock.
SDATAINVAL#	I	OD V _{CC} CORE	1	SDATAINVAL# is driven by the system to pace the data into the processor. SDATAINVAL# can be used to introduce an arbitrary number of cycles between octawords into the processor.
SDATAOUTCLK[3:0]#	O	OD V _{CC} CORE	4	SDATAOUTCLK[3:0]# is the single-ended source-synchronous clock driven by the processor to transfer data on SDATA[63:0]#. Each 16-bit data word on SDATA[63:0]# is skewed-aligned with this clock.
SDATAOUTVAL#	I	OD V _{CC} CORE	1	SDATAOUTVAL# is driven by the system to pace the data from the processor. SDATAOUTVAL# can be used to introduce an arbitrary number of cycles between quadwords from the processor.

Table 21. AMD Athlon™ System Bus and Legacy Interface Signals (continued)

Signal Name	Type	Level	Number of Pins	Description
SFILLVAL#	I	OD V _{CCCORE}	1	SFILLVAL# validates a data transfer to the processor. The system may tie this pin to the asserted state (validating all fills). The processor samples SFILLVAL# at the first or second data beat.
SMI#	I	OD V _{CCCORE}	1	SMI# is an input that causes the processor to enter the system management mode.
STPCLK#	I	OD V _{CCCORE}	1	STPCLK# is an input that causes the processor to enter a lower power mode and issue a Stop Grant special cycle.
SYSCLK SYSCLK#	I		2	SYSCLK and SYSCLK# are differential input clock signals provided to the processor's PLL from a system-clock generator.
VCC2SEL	O	OD V _{CCCORE}	1	VCC2SEL is an output to the system that indicates the required core voltage for the L2 SRAM. High=2.5V, Low=3.3V.
VID[3:0]	O	OD V _{CCCORE}	4	The VID[3:0] signals are outputs to the motherboard that indicate the required V _{CCCORE} voltage for the processor.

11 Logic Symbol Diagram

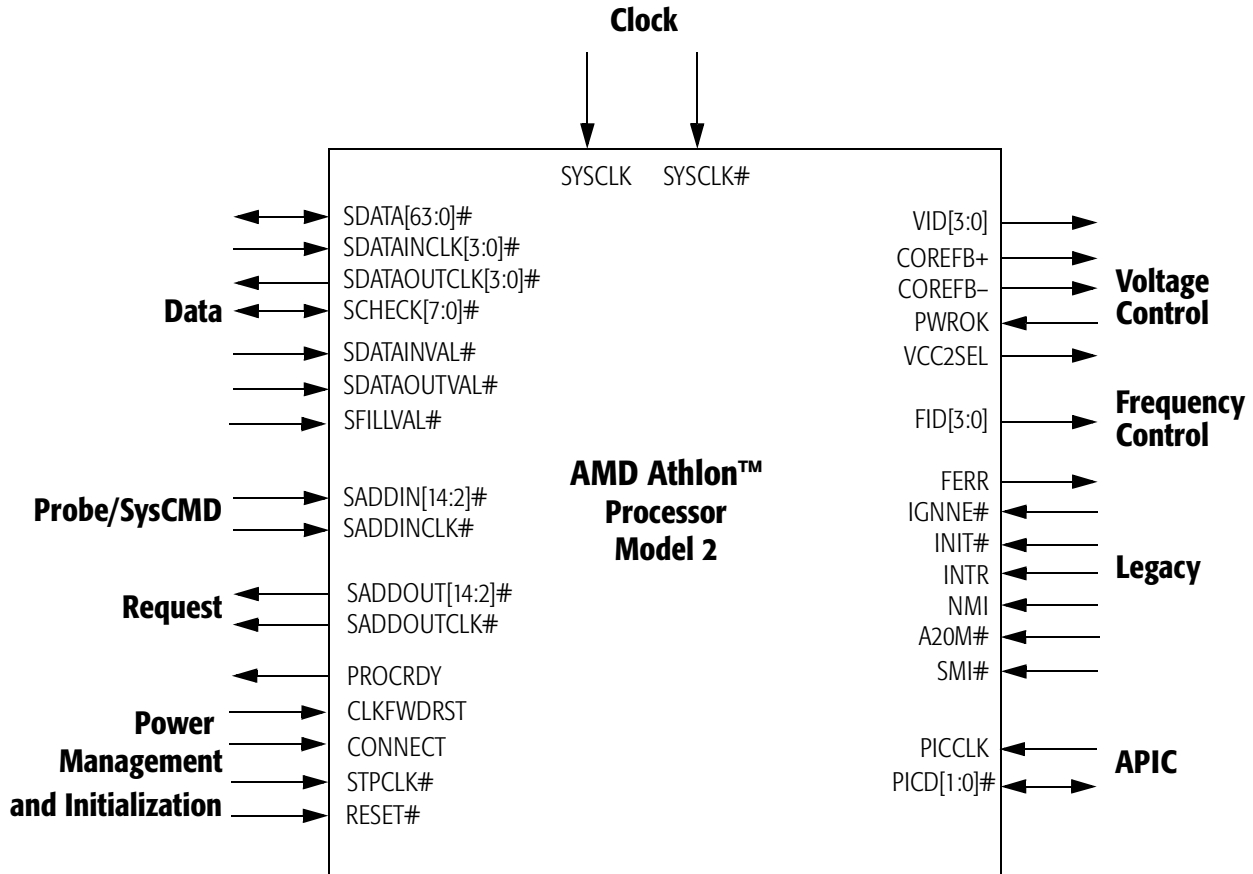

Figure 16. Logic Symbol Diagram for AMD Athlon Processor Model 2

12 Power Management

The power management features of the AMD Athlon processor Model 2 are functionally the same as the AMD Athlon processor Model 1. For information about power management for the AMD Athlon processor Model 2, see Chapter 4, “Power Management” on page 11.

13 Thermal Design

The AMD Athlon processor Model 2 has improved thermal performance compared to the AMD Athlon processor Model 1, due to the process enhancement of 0.18-micron technology. For information about thermal design, including layout and airflow considerations, see the *AMD Athlon™ Processor Thermal Solution Design Application Note*, order# 22439.

14 Electrical Data

14.1 The AMD Athlon™ System Bus

The AMD Athlon system bus architecture is designed to deliver unprecedented data movement bandwidth for next-generation x86 platforms, as well as the high performance required by enterprise-class application software. The system bus architecture consists of three high-speed channels (a unidirectional processor request channel, a unidirectional snoop channel, and a 72-bit bidirectional data channel, including 8-bit error code correction [ECC] protection), source-synchronous clocking, and a packet-based protocol. In addition, the system bus supports several control, clock, and legacy signals. The interface signals use a HSTL-like, low-voltage swing signaling technology contained within the Slot A mechanical connector, which is mechanically compatible with the industry-standard SC242 connector.

14.2 Signal Groupings

The AMD Athlon system bus is the processor connection to a memory and I/O controller or a shared multiprocessor controller. The system interface can be broken down into four signal groups plus power and ground connections. These groups are listed in Table 22 on page 68. The first group connects the AMD Athlon processor to the system controller and uses a source-synchronous, or clock-forwarded clocking scheme. Using this technique, the clocks and data travel in the same direction down the transmission line and arrive together. The second group connects the AMD Athlon processor to the peripheral bus controller, but unlike the system controller group, these signals do not use a source-synchronous scheme. The third group is the control group, which contains signals that interface with the power supply of the system. The fourth group contains the system clock. This is the input clock for the AMD Athlon processor and is the source for all other clocks generated by the AMD Athlon processor module.

Table 22. AMD Athlon™ Processor Interface Signal Groupings

Name	Buffer Type	Signals
System Controller (Northbridge)	Open-Drain	SADDIN[14:2]#, SADDOUT[14:2]#, SADDINCLK#, SADDOUTCLK#, SFILLVAL#, SDATAINVAL#, SDATAOUTVAL#, SDATA[63:0]#, SDATAINCLK[3:0]#, SDATAOUTCLK[3:0]#, SCHECK[7:0]#, FID[3:0], CLKFWRST, PROCRDY, CONNECT
Peripheral Bus Controller (Southbridge)		RESET#, INTR, NMI, SMI#, INIT#, A20M#, FERR, IGNNE#, STPCLK#, PICD[1:0]#, PICCLK
Clock		SYSCLK, SYSCLK#
Control		VID[3:0], VCC2SEL, COREFB+, COREFB-, PWROK
Power		VCC_CORE, VCC_SRAM, GND

Clock Forwarding

The signals in the system controller group can be divided into six source-synchronous groups, as shown in Table 23. Groups that contain two clocks are bidirectional, source-synchronous groups. These groups use a different clock, based on the operation being performed. For example, when data is sent from the AMD Athlon processor to the system controller, SDATAOUTCLK# is used, and when data is sent from the system controller to the AMD Athlon processor, SDATAINCLK# is used. The topology is point-to-point and active terminations.

Table 23. Source-Synchronous Clock Signal Groups

Group	Signals in Group	Clock
SData0	SDATA[15:0]#, SCHECK[0:1]#	SDATAINCLK[0]#, SDATAOUTCLK[0]#
SData1	SDATA[31:16]#, SCHECK[2:3]#	SDATAINCLK[1]#, SDATAOUTCLK[1]#
SData2	SDATA[47:32]#, SCHECK[4:5]#	SDATAINCLK[2]#, SDATAOUTCLK[2]#
SData3	SDATA[63:48]#, SCHECK[6:7]#	SDATAINCLK[3]#, SDATAOUTCLK[3]#
SAddIn	SADDIN[14:2]#, SFILLVAL#, SDATAINVAL#, SDATAOUTVAL#	SADDINCLK#
SAddOut	SADDOUT[14:2]#	SADDOUTCLK#

14.3 Voltage Identification

The AMD Athlon processor Model 2 provides four voltage ID lines back to the system for proper configuration of the processor core voltage. For information concerning voltage identification for the AMD Athlon processor Model 2, see “Voltage Identification” on page 25.

14.4 Frequency Identification

The AMD Athlon processor Model 2 provides four frequency ID signals (FID[3:0]) to the system controller to indicate the SYSCLK multiplier at which the processor core operates. This mechanism is automatic, using the system controller and the BIOS without jumpers on the motherboard to set the operating frequency of the AMD Athlon processor.

14.5 Decoupling

See the *AMD Athlon™ Processor Voltage Regulation Design Application Note*, order# 22651 for information about the decoupling required on the motherboard for use with the AMD Athlon processor Model 2.

14.6 Termination

There is no termination difference between the AMD Athlon processor Model 2 and the AMD Athlon processor Model 1. For information concerning termination, see “Termination” on page 26.

14.7 Operating Ranges

The AMD Athlon processor is designed to provide functional operation if the voltage and temperature parameters are within the limits defined in Table 24.

Table 24. Operating Ranges

Parameter	Description	Min	Max	Notes
VCC_CORE	AMD Athlon™ processor core supply	1.5 V	1.7 V	1
VCC_CORE	AMD Athlon™ processor core supply in Sleep state	1.2 V	1.7 V	2
VCC_SRAM	2.5 V SRAM core supply	2.475 V	2.625 V	3
VCC_SRAM	3.3 V SRAM core supply	3.15 V	3.45 V	4
T _{PLATE}	Temperature of thermal plate		70° C	
Notes: <ol style="list-style-type: none"> For normal operating conditions (nominal VCC_CORE is 1.6 V) For Sleep state operating conditions Value of VCC_SRAM when VCC2SEL is High Value of VCC_SRAM when VCC2SEL is Low 				

14.8 Absolute Ratings

The AMD Athlon processor should not be subjected to conditions exceeding the absolute ratings listed in Table 25, as such conditions may adversely affect long term reliability or result in functional damage.

Table 25. Absolute Ratings

Parameter	Description	Min	Max	Notes
VCC_CORE	AMD Athlon™ processor core supply	-0.5 V	nominal + 0.5 V	
VCC_SRAM	2.5 V SRAM core supply	-0.5 V	3.0 V	1
VCC_SRAM	3.3 V SRAM core supply	-0.5 V	4.0 V	2
V _{PIN}	Voltage on any system bus pin	TBD	TBD	
T _{STORAGE}	Storage temperature of processor	-40° C	85° C	
Notes: <ol style="list-style-type: none"> Value of VCC_SRAM when VCC2SEL is Low Value of VCC_SRAM when VCC2SEL is High 				

14.9 Power Dissipation

Table 26 shows the typical and maximum power dissipation of the AMD Athlon processor during normal and reduced power states.

Table 26. Typical and Maximum Power Dissipation (Model 2)

Clock Control State	550 MHz	600 MHz	650 MHz	700 MHz	750 MHz	Note
Normal (Maximum Thermal Power)	34 W	36 W	39 W	42 W	43 W	1, 2
Normal (Typical Thermal Power)	30 W	32 W	35 W	37 W	38 W	1, 2
Stop Grant (Maximum)	4 W	4 W	4 W	4 W	4 W	3
Notes: 1) Power numbers include power for a 512-Kbyte L2 cache running at maximum case current conditions. 2) Measured at 1.6V nominal 3) Measured at 1.3V for Sleep state operating conditions						

14.10 DC Characteristics

The DC characteristics of the AMD Athlon processor Model 2 are shown in Table 27. These values are defined at the card edge of the AMD Athlon processor module.

Table 27. DC Characteristics (Model 2)

Symbol	Parameter	Condition	Min	Max	Units	Notes
VCC_CORE	IO Supply Voltage		1.5	1.7	V	1
V _{REF}	DC Input Reference Voltage		(0.47*VCC_CORE) -50	(0.47*VCC_CORE) +50	mV	2
I _{VREF}	V _{REF} Input Pin Current	0 < V _{IN} < VCC_CORE	-250	+250	μA	3
V _{IH-DC}	DC Input High Voltage		V _{REF} + 325	VCC_CORE + 300	mV	
V _{IL-DC}	DC Input Low Voltage		-300	V _{REF} + 75	mV	
V _{IH-AC}	AC Input High Voltage		V _{REF} + 450	VCC_CORE + 500	mV	
V _{IL-AC}	AC Input Low Voltage		-500	V _{REF} - 50	mV	
V _{OH-DC}	DC Output High Voltage		VCC_CORE	VCC_CORE + 300	mV	4
V _{OL-DC}	DC Output Low Voltage	I _{OUT} = I _{OL-DC-MAX}	-300	+300	mV	4
V _{OH-AC}	AC Output High Voltage		VCC_CORE	VCC_CORE + 500	mV	4
V _{OL-AC}	AC Output Low Voltage		-500	400	mV	4
I _{OL-DC}	DC Output Current Low	V _{OUT} = V _{OL-DC-MAX}	-	33	mA	
I _{LEAK}	Tristate Leakage	0 < V _{IN} < VCC_CORE	-100	+100	μA	5
I _{IH}	Input High Current	V _{IN} =V _{IH-DC-MIN}	0	500	μA	
I _{IL}	Input Low Current	V _{IN} =V _{IL-DC-MAX}	0	500	μA	

Notes:

- Nominal VCC_CORE is 1.6v.
- V_{REF}:
 - V_{REF} is nominally set by a (1%) resistor divider from VCC_CORE.
 - The suggested divider resistor values are 90.9 ohms over 80.6 ohms to produce a divisor of 0.47.
 - The internal V_{REF} (V_{REF-INT}) is the external V_{REF} scaled by 0.80 (V_{REF-INT} = (V_{REF}/0.80)). (Processor pin SysVrefMode = High)
 - Given: VCC_CORE = 1.6V, V_{REF} = 752mV (1.6 * 0.47), V_{REF-INT} = 940mV (752mV/0.8).
 - Peak-to-Peak AC noise on V_{REF} (AC) should not exceed 2% of V_{REF} (DC).
- I_{VREF} should be measured at nominal V_{REF}.
- V_{OL-DC-MAX}, V_{OL-AC-MAX}, V_{OH-DC-MIN} and V_{OH-AC-MIN} are specified at T = 100°C and VCC_CORE = 1.4V.
- Does not apply to V_{REF}.
- The following signals have twice the capacitance because they connect to two input pads—SDATAINCLK[3:0]# and SYSCLK, SYSCLK#. SDATAINCLK[3:0]# connects 2 byte clocks to form a word sized clock. SYSCLK connects to CLKIN/RSTCLK. SYSCLK# connects to CLKIN#/RSTCLK#.
- Measured at maximum VCC_CORE = 1.70 V—The maximum power supply current must be taken into account when designing a power supply.

Table 27. DC Characteristics (Model 2) (continued)

Symbol	Parameter	Condition	Min	Max	Units	Notes
C _{IN}	Input Pin Capacitance		4	12	pF	6
I _{CC}	Power Supply Current	550 MHz		21.7	A	7
		600 MHz		23.3	A	7
		650 MHz		24.9	A	7
		700 MHz		26.6	A	7
		750 MHz		28.2	A	7

Notes:

- Nominal VCC_{CORE} is 1.6V.
- V_{REF}:
 - V_{REF} is nominally set by a (1%) resistor divider from VCC_{CORE}.
 - The suggested divider resistor values are 90.9 ohms over 80.6 ohms to produce a divisor of 0.47.
 - The internal V_{REF} (V_{REF-INT}) is the external V_{REF} scaled by 0.80 (V_{REF-INT} = (V_{REF}/0.80)). (Processor pin SysVrefMode = High)
 - Given: VCC_{CORE} = 1.6V, V_{REF} = 752mV (1.6 * 0.47), V_{REF-INT} = 940mV (752mV/0.8).
 - Peak-to-Peak AC noise on V_{REF} (AC) should not exceed 2% of V_{REF} (DC).
- I_{VREF} should be measured at nominal V_{REF}.
- V_{OL-DC-MAX}, V_{OL-AC-MAX}, V_{OH-DC-MIN} and V_{OH-AC-MIN} are specified at T = 100°C and VCC_{CORE} = 1.4V.
- Does not apply to V_{REF}.
- The following signals have twice the capacitance because they connect to two input pads—SDATAINCLK[3:0]# and SYSCLK, SYSCLK#. SDATAINCLK[3:0]# connects 2 byte clocks to form a word sized clock. SYSCLK connects to CLKIN/RSTCLK. SYSCLK# connects to CLKIN#/RSTCLK#.
- Measured at maximum VCC_{CORE} = 1.70 V—The maximum power supply current must be taken into account when designing a power supply.

14.11 AC Characteristics

The AC characteristics of the AMD Athlon processor Model 2 are the same as the AMD Athlon processor Model 1. For information about AC characteristics of the AMD Athlon processor Model 2, see “AC Characteristics” on page 32.

15 Mechanical Data

15.1 Introduction

Due to the addition of APIC in the AMD Athlon processor Model 2, three additional APIC-related signals have been designated, which are detailed in Tables 28 through 30.

The mechanical dimensions of the AMD Athlon processor Model 2 remain unchanged with the integration of 0.18-micron process technology. For more information, see Chapter 7, “Mechanical Data” on page 35.

15.2 AMD Athlon™ Processor Card-Edge Signal Listing

Tables 28 through 30 shows the Slot A signals and pins ordered by pin number, pin name, and their physical position on the slot, respectively. The *High* and *Low* designation in the *Pin Name* column in Table 30 refers to the staggered high/low arrangement of the pins on the slot.

Table 28. AMD Athlon™ Processor Signals Ordered by Pin Number

Pin No.	Pin Name	Pin No.	Pin Name
A1	VCC2SEL	B1	SADDOUT[14]#
A2	VCC_SRAM[7]	B2	GND[10]
A3	PICCLK	B3	SADDOUT[13]#
A4	VCC_SRAM[6]	B4	SADDOUT[7]#
A5	PICD[0]	B5	GND[51]
A6	VCC_SRAM[5]	B6	SADDOUTCLK#
A7	PICD[1]	B7	GND[7]
A8	VCC_SRAM[4]	B8	SADDOUT[12]#
A9	SMI#	B9	GND[21]
A10	VCC_SRAM[3]	B10	SADDOUT[9]#
A11	FERR	B11	SADDOUT[8]#
A12	INIT#	B12	GND[20]
A13	NMI	B13	SADDOUT[5]#
A14	VCC_SRAM[2]	B14	SADDOUT[6]#
A15	INTR	B15	GND[30]
A16	VCC_SRAM[1]	B16	SADDOUT[2]#
A17	RESET#	B17	GND[44]
A18	STPCLK#	B18	SADDOUT[3]#
A19	IGNNE#	B19	GND[19]
A20	VCC_SRAM[8]	B20	SDATAOUTCLK[3]#
A21	A20M#	B21	GND[40]
A22	VCC_CORE[41]	B22	SCHECK[6]#
A23	SADDOUT[10]#	B23	SDATA[53]#
A24	VCC_CORE[1]	B24	GND[8]
A25	SADDOUT[11]#	B25	SDATA[49]#
A26	VCC_CORE[19]	B26	SDATA[63]#
A27	SADDOUT[4]#	B27	GND[32]
A28	VCC_CORE[44]	B28	SDATAINCLK[3]#
A29	SDATA[55]#	B29	GND[3]
A30	VCC_CORE[10]	B30	SDATA[62]#
A31	SDATA[54]#	B31	GND[1]
A32	VCC_CORE[11]	B32	SDATA[60]#
A33	SDATA[52]#	B33	GND[13]
A34	VCC_CORE[35]	B34	SCHECK[7]#
A35	SDATA[61]#	B35	SDATA[59]#

Table 28. AMD Athlon™ Processor Signals Ordered by Pin Number (continued)

Pin No.	Pin Name	Pin No.	Pin Name
A36	VCC_CORE[25]	B36	GND[2]
A37	SDATA[50]#	B37	SDATA[58]#
A38	VCC_CORE[4]	B38	SDATA[57]#
A39	SDATA[51]#	B39	GND[16]
A40	VCC_CORE[26]	B40	SDATA[39]#
A41	SDATA[48]#	B41	GND[39]
A42	VCC_CORE[34]	B42	SDATA[56]#
A43	SDATA[36]#	B43	GND[38]
A44	VCC_CORE[16]	B44	SDATA[47]#
A45	SDATA[46]#	B45	SDATA[38]#
A46	VCC_CORE[38]	B46	GND[41]
A47	SDATA[37]#	B47	SDATA[45]#
A48	VCC_CORE[20]	B48	SDATA[44]#
A49	SDATA[35]#	B49	GND[37]
A50	VCC_CORE[30]	B50	SDATAINCLK[2]#
A51	SCHECK[4]#	B51	GND[34]
A52	VCC_CORE[3]	B52	SCHECK[5]#
A53	SDATA[34]#	B53	GND[33]
A54	VCC_CORE[31]	B54	SDATA[43]#
A55	SDATA[33]#	B55	SDATA[42]#
A56	VCC_CORE[29]	B56	GND[22]
A57	SDATA[32]#	B57	SDATA[41]#
A58	VCC_CORE[7]	B58	SDATA[40]#
A59	SDATAOUTCLK[2]#	B59	GND[50]
A60	VCC_CORE[18]	B60	SDATAOUTCLK[1]#
A61	SDATA[30]#	B61	GND[31]
A62	VCC_CORE[15]	B62	SDATA[22]#
A63	SDATA[31]#	B63	GND[35]
A64	VCC_CORE[14]	B64	SDATA[23]#
A65	SCHECK[3]#	B65	GND[36]
A66	VCC_CORE[33]	B66	SDATA[21]#
A67	SDATAINCLK[1]#	B67	GND[49]
A68	VCC_CORE[32]	B68	SDATA[20]#
A69	SDATA[29]#	B69	GND[14]
A70	SDATA[28]#	B70	SDATA[19]#
A71	VCC_CORE[9]	B71	SCHECK[2]#
A72	SDATA[26]#	B72	GND[9]
A73	SDATA[27]#	B73	SDATA[18]#
A74	VCC_CORE[42]	B74	SDATA[7]#
A75	SDATA[25]#	B75	GND[23]
A76	VCC_CORE[13]	B76	SDATA[17]#
A77	SDATA[24]#	B77	GND[15]
A78	VCC_CORE[27]	B78	SDATA[16]#
A79	SDATA[15]#	B79	GND[27]
A80	VCC_CORE[24]	B80	SDATA[6]#

Table 28. AMD Athlon™ Processor Signals Ordered by Pin Number (continued)

Pin No.	Pin Name	Pin No.	Pin Name
A81	SDATA[1]#	B81	SDATA[5]#
A82	VCC_CORE[2]	B82	GND[28]
A83	SDATA[12]#	B83	SCHECK[0]#
A84	VCC_CORE[23]	B84	SDATA[4]#
A85	SCHECK[1]#	B85	GND[29]
A86	VCC_CORE[5]	B86	SDATA[2]#
A87	SDATA[8]#	B87	GND[25]
A88	VCC_CORE[39]	B88	SDATAINCLK[0]#
A89	SDATA[10]#	B89	GND[26]
A90	VCC_CORE[22]	B90	SDATA[3]#
A91	SDATAOUTCLK[0]#	B91	GND[6]
A92	VCC_CORE[21]	B92	SDATA[0]#
A93	SADDIN[7]#	B93	GND[5]
A94	VCC_CORE[40]	B94	SDATA[13]#
A95	SADDIN[6]#	B95	SDATA[14]#
A96	VCC_CORE[37]	B96	GND[4]
A97	SADDIN[8]#	B97	SDATA[11]#
A98	VCC_CORE[6]	B98	SDATA[9]#
A99	SDATAOUTVAL#	B99	GND[17]
A100	VCC_CORE[28]	B100	SADDIN[5]#
A101	SDATAINVAL#	B101	GND[18]
A102	VCC_CORE[36]	B102	SADDIN[11]#
A103	CONNECT	B103	GND[45]
A104	VCC_CORE[12]	B104	SADDIN[2]#
A105	CLKFWRST	B105	GND[48]
A106	PROCRDY	B106	SADDIN[3]#
A107	VCC_CORE[43]	B107	SADDIN[4]#
A108	SYSCLK#	B108	GND[46]
A109	SYSCLK	B109	SADDIN[10]#
A110	VCC_CORE[17]	B110	SADDIN[9]#
A111	PWROK	B111	GND[43]
A112	VID[0]	B112	SADDIN[13]#
A113	VID[1]	B113	GND[42]
A114	VID[2]	B114	SADDINCLK#
A115	VID[3]	B115	GND[11]
A116	FID[3]	B116	SADDIN[14]#
A117	FID[2]	B117	GND[12]
A118	FID[1]	B118	SFILLVAL#
A119	FID[0]	B119	GND[47]
A120	COREFB+	B120	SADDIN[12]#
A121	COREFB-	B121	GND[24]

Table 29. AMD Athlon™ Processor Signals Ordered by Pin Name

Pin Name	Pin No.	Pin Name	Pin No.
A20M#	A21	GND[25]	B87
CLKFWRST	A105	GND[26]	B89
CONNECT	A103	GND[27]	B79
COREFB+	A120	GND[28]	B82
COREFB-	A121	GND[29]	B85
FERR	A11	GND[30]	B15
FID[0]	A119	GND[31]	B61
FID[1]	A118	GND[32]	B27
FID[2]	A117	GND[33]	B53
FID[3]	A116	GND[34]	B51
GND[1]	B31	GND[35]	B63
GND[2]	B36	GND[36]	B65
GND[3]	B29	GND[37]	B49
GND[4]	B96	GND[38]	B43
GND[5]	B93	GND[39]	B41
GND[6]	B91	GND[40]	B21
GND[7]	B7	GND[41]	B46
GND[8]	B24	GND[42]	B113
GND[9]	B72	GND[43]	B111
GND[10]	B2	GND[44]	B17
GND[11]	B115	GND[45]	B103
GND[12]	B117	GND[46]	B108
GND[13]	B33	GND[47]	B119
GND[14]	B69	GND[48]	B105
GND[15]	B77	GND[49]	B67
GND[16]	B39	GND[50]	B59
GND[17]	B99	GND[51]	B5
GND[18]	B101	IGNNE#	A19
GND[19]	B19	INIT#	A12
GND[20]	B12	INTR	A15
GND[21]	B9	NMI	A13
GND[22]	B56	PICCLK	A3
GND[23]	B75	PICD[0]	A5
GND[24]	B121	PICD[1]	A7
PROCRDY	A106	SCHECK[3]#	A65
PWROK	A111	SCHECK[4]#	A51
RESET#	A17	SCHECK[5]#	B52
SADDIN[2]#	B104	SCHECK[6]#	B22
SADDIN[3]#	B106	SCHECK[7]#	B34
SADDIN[4]#	B107	SDATA[0]#	B92
SADDIN[5]#	B100	SDATA[1]#	A81
SADDIN[6]#	A95	SDATA[2]#	B86
SADDIN[7]#	A93	SDATA[3]#	B90
SADDIN[8]#	A97	SDATA[4]#	B84
SADDIN[9]#	B110	SDATA[5]#	B81

Table 29. AMD Athlon™ Processor Signals Ordered by Pin Name (continued)

Pin Name	Pin No.	Pin Name	Pin No.
SADDIN[10]#	B109	SDATA[6]#	B80
SADDIN[11]#	B102	SDATA[7]#	B74
SADDIN[12]#	B120	SDATA[8]#	A87
SADDIN[13]#	B112	SDATA[9]#	B98
SADDIN[14]#	B116	SDATA[10]#	A89
SADDINCLK#	B114	SDATA[11]#	B97
SADDOUT[2]#	B16	SDATA[12]#	A83
SADDOUT[3]#	B18	SDATA[13]#	B94
SADDOUT[4]#	A27	SDATA[14]#	B95
SADDOUT[5]#	B13	SDATA[15]#	A79
SADDOUT[6]#	B14	SDATA[16]#	B78
SADDOUT[7]#	B4	SDATA[17]#	B76
SADDOUT[8]#	B11	SDATA[18]#	B73
SADDOUT[9]#	B10	SDATA[19]#	B70
SADDOUT[10]#	A23	SDATA[20]#	B68
SADDOUT[11]#	A25	SDATA[21]#	B66
SADDOUT[12]#	B8	SDATA[22]#	B62
SADDOUT[13]#	B3	SDATA[23]#	B64
SADDOUT[14]#	B1	SDATA[24]#	A77
SADDOUTCLK#	B6	SDATA[25]#	A75
SCHECK[0]#	B83	SDATA[26]#	A72
SCHECK[1]#	A85	SDATA[27]#	A73
SCHECK[2]#	B71	SDATA[28]#	A70
SDATA[29]#	A69	SDATA[63]#	B26
SDATA[30]#	A61	SDATAINCLK[0]#	B88
SDATA[31]#	A63	SDATAINCLK[1]#	A67
SDATA[32]#	A57	SDATAINCLK[2]#	B50
SDATA[33]#	A55	SDATAINCLK[3]#	B28
SDATA[34]#	A53	SDATAINVAL#	A101
SDATA[35]#	A49	SDATAOUTCLK[0]#	A91
SDATA[36]#	A43	SDATAOUTCLK[1]#	B60
SDATA[37]#	A47	SDATAOUTCLK[2]#	A59
SDATA[38]#	B45	SDATAOUTCLK[3]#	B20
SDATA[39]#	B40	SDATAOUTVAL#	A99
SDATA[40]#	B58	SFILLVAL#	B118
SDATA[41]#	B57	SMI#	A9
SDATA[42]#	B55	STPCLK#	A18
SDATA[43]#	B54	SYSCLK	A109
SDATA[44]#	B48	SYSCLK#	A108
SDATA[45]#	B47	VCC2SEL	A1
SDATA[46]#	A45	VCC_CORE[1]	A24
SDATA[47]#	B44	VCC_CORE[2]	A82
SDATA[48]#	A41	VCC_CORE[3]	A52
SDATA[49]#	B25	VCC_CORE[4]	A38
SDATA[50]#	A37	VCC_CORE[5]	A86

Table 29. AMD Athlon™ Processor Signals Ordered by Pin Name (continued)

Pin Name	Pin No.	Pin Name	Pin No.
SDATA[51]#	A39	VCC_CORE[6]	A98
SDATA[52]#	A33	VCC_CORE[7]	A58
SDATA[53]#	B23	VCC_CORE[9]	A71
SDATA[54]#	A31	VCC_CORE[10]	A30
SDATA[55]#	A29	VCC_CORE[11]	A32
SDATA[56]#	B42	VCC_CORE[12]	A104
SDATA[57]#	B38	VCC_CORE[13]	A76
SDATA[58]#	B37	VCC_CORE[14]	A64
SDATA[59]#	B35	VCC_CORE[15]	A62
SDATA[60]#	B32	VCC_CORE[16]	A44
SDATA[61]#	A35	VCC_CORE[17]	A110
SDATA[62]#	B30	VCC_CORE[18]	A60
VCC_CORE[19]	A26	VCC_CORE[38]	A46
VCC_CORE[20]	A48	VCC_CORE[39]	A88
VCC_CORE[21]	A92	VCC_CORE[40]	A94
VCC_CORE[22]	A90	VCC_CORE[41]	A22
VCC_CORE[23]	A84	VCC_CORE[42]	A74
VCC_CORE[24]	A80	VCC_CORE[43]	A107
VCC_CORE[25]	A36	VCC_CORE[44]	A28
VCC_CORE[26]	A40	VCC_SRAM[1]	A16
VCC_CORE[27]	A78	VCC_SRAM[2]	A14
VCC_CORE[28]	A100	VCC_SRAM[3]	A10
VCC_CORE[29]	A56	VCC_SRAM[4]	A8
VCC_CORE[30]	A50	VCC_SRAM[5]	A6
VCC_CORE[31]	A54	VCC_SRAM[6]	A4
VCC_CORE[32]	A68	VCC_SRAM[7]	A2
VCC_CORE[33]	A66	VCC_SRAM[8]	A20
VCC_CORE[34]	A42	VID[0]	A112
VCC_CORE[35]	A34	VID[1]	A113
VCC_CORE[36]	A102	VID[2]	A114
VCC_CORE[37]	A96	VID[3]	A115

Table 30. AMD Athlon™ Processor Signals Ordered by Physical Location

Pin No.	Pin Name—High	Pin Name—Low	Pin No.	Pin No.	Pin Name—High	Pin Name—Low	Pin No.
A121	COREFB-	COREFB+	A120	B121	GND[24]	SADDIN[12]#	B120
A119	FID[0]	FID[1]	A118	B119	GND[47]	SFILLVAL#	B118
A117	FID[2]	FID[3]	A116	B117	GND[12]	SADDIN[14]#	B116
A115	VID[3]	VID[2]	A114	B115	GND[11]	SADDINCLK#	B114
A113	VID[1]	VID[0]	A112	B113	GND[42]	SADDIN[13]#	B112
A111	PWROK	VCC_CORE[17]	A110	B111	GND[43]	SADDIN[9]#	B110
A109	SYSCLK	SYSCLK#	A108	B109	SADDIN[10]#	GND[46]	B108
A107	VCC_CORE[43]	PROCRDY	A106	B107	SADDIN[4]#	SADDIN[3]#	B106
A105	CLKFWRDST	VCC_CORE[12]	A104	B105	GND[48]	SADDIN[2]#	B104
A103	CONNECT	VCC_CORE[36]	A102	B103	GND[45]	SADDIN[11]#	B102
A101	SDATAINVAL#	VCC_CORE[28]	A100	B101	GND[18]	SADDIN[5]#	B100
A99	SDATAOUTVAL#	VCC_CORE[6]	A98	B99	GND[17]	SDATA[9]#	B98
A97	SADDIN[8]#	VCC_CORE[37]	A96	B97	SDATA[11]#	GND[4]	B96
A95	SADDIN[6]#	VCC_CORE[40]	A94	B95	SDATA[14]#	SDATA[13]#	B94
A93	SADDIN[7]#	VCC_CORE[21]	A92	B93	GND[5]	SDATA[0]#	B92
A91	SDATAOUTCLK[0]#	VCC_CORE[22]	A90	B91	GND[6]	SDATA[3]#	B90
A89	SDATA[10]#	VCC_CORE[39]	A88	B89	GND[26]	SDATAINCLK[0]#	B88
A87	SDATA[8]#	VCC_CORE[5]	A86	B87	GND[25]	SDATA[2]#	B86
A85	SCHECK[1]#	VCC_CORE[23]	A84	B85	GND[29]	SDATA[4]#	B84
A83	SDATA[12]#	VCC_CORE[2]	A82	B83	SCHECK[0]#	GND[28]	B82
A81	SDATA[1]#	VCC_CORE[24]	A80	B81	SDATA[5]#	SDATA[6]#	B80
A79	SDATA[15]#	VCC_CORE[27]	A78	B79	GND[27]	SDATA[16]#	B78
A77	SDATA[24]#	VCC_CORE[13]	A76	B77	GND[15]	SDATA[17]#	B76
A75	SDATA[25]#	VCC_CORE[42]	A74	B75	GND[23]	SDATA[7]#	B74
A73	SDATA[27]#	SDATA[26]#	A72	B73	SDATA[18]#	GND[9]	B72
A71	VCC_CORE[9]	SDATA[28]#	A70	B71	SCHECK[2]#	SDATA[19]#	B70
A69	SDATA[29]#	VCC_CORE[32]	A68	B69	GND[14]	SDATA[20]#	B68
A67	SDATAINCLK[1]#	VCC_CORE[33]	A66	B67	GND[49]	SDATA[21]#	B66
A65	SCHECK[3]#	VCC_CORE[14]	A64	B65	GND[36]	SDATA[23]#	B64
A63	SDATA[31]#	VCC_CORE[15]	A62	B63	GND[35]	SDATA[22]#	B62
A61	SDATA[30]#	VCC_CORE[18]	A60	B61	GND[31]	SDATAOUTCLK[1]#	B60
A59	SDATAOUTCLK[2]#	VCC_CORE[7]	A58	B59	GND[50]	SDATA[40]#	B58
A57	SDATA[32]#	VCC_CORE[29]	A56	B57	SDATA[41]#	GND[22]	B56
A55	SDATA[33]#	VCC_CORE[31]	A54	B55	SDATA[42]#	SDATA[43]#	B54
A53	SDATA[34]#	VCC_CORE[3]	A52	B53	GND[33]	SCHECK[5]#	B52
A51	SCHECK[4]#	VCC_CORE[30]	A50	B51	GND[34]	SDATAINCLK[2]#	B50
A49	SDATA[35]#	VCC_CORE[20]	A48	B49	GND[37]	SDATA[44]#	B48
A47	SDATA[37]#	VCC_CORE[38]	A46	B47	SDATA[45]#	GND[41]	B46
A45	SDATA[46]#	VCC_CORE[16]	A44	B45	SDATA[38]#	SDATA[47]#	B44
A43	SDATA[36]#	VCC_CORE[34]	A42	B43	GND[38]	SDATA[56]#	B42
A41	SDATA[48]#	VCC_CORE[26]	A40	B41	GND[39]	SDATA[39]#	B40
A39	SDATA[51]#	VCC_CORE[4]	A38	B39	GND[16]	SDATA[57]#	B38
A37	SDATA[50]#	VCC_CORE[25]	A36	B37	SDATA[58]#	GND[2]	B36
A35	SDATA[61]#	VCC_CORE[35]	A34	B35	SDATA[59]#	SCHECK[7]#	B34
A33	SDATA[52]#	VCC_CORE[11]	A32	B33	GND[13]	SDATA[60]#	B32
A31	SDATA[54]#	VCC_CORE[10]	A30	B31	GND[1]	SDATA[62]#	B30
A29	SDATA[55]#	VCC_CORE[44]	A28	B29	GND[3]	SDATAINCLK[3]#	B28
A27	SADDOUT[4]#	VCC_CORE[19]	A26	B27	GND[32]	SDATA[63]#	B26
A25	SADDOUT[11]#	VCC_CORE[1]	A24	B25	SDATA[49]#	GND[8]	B24
A23	SADDOUT[10]#	VCC_CORE[41]	A22	B23	SDATA[53]#	SCHECK[6]#	B22
A21	A20M#	VCC_SRAM[8]	A20	B21	GND[40]	SDATAOUTCLK[3]#	B20
A19	IGNNE#	STPCLK#	A18	B19	GND[19]	SADDOUT[3]#	B18
A17	RESET#	VCC_SRAM[1]	A16	B17	GND[44]	SADDOUT[2]#	B16
A15	INTR	VCC_SRAM[2]	A14	B15	GND[30]	SADDOUT[6]#	B14
A13	NMI	INIT#	A12	B13	SADDOUT[5]#	GND[20]	B12
A11	FERR#	VCC_SRAM[3]	A10	B11	SADDOUT[8]#	SADDOUT[9]#	B10
A9	SMI#	VCC_SRAM[4]	A8	B9	GND[21]	SADDOUT[12]#	B8
A7	PICD[1]	VCC_SRAM[5]	A6	B7	GND[7]	SADDOUTCLK#	B6
A5	PICD[0]	VCC_SRAM[6]	A4	B5	GND[51]	SADDOUT[7]#	B4
A3	PICCLK	VCC_SRAM[7]	A2	B3	SADDOUT[13]#	GND[10]	B2
A1	VCC2SEL			B1	SADDOUT[14]#		

16 Ordering Information

Standard AMD Athlon™ Processor Products

AMD standard products are available in several operating ranges. The ordering part number (OPN) is formed by a combination of the elements below.

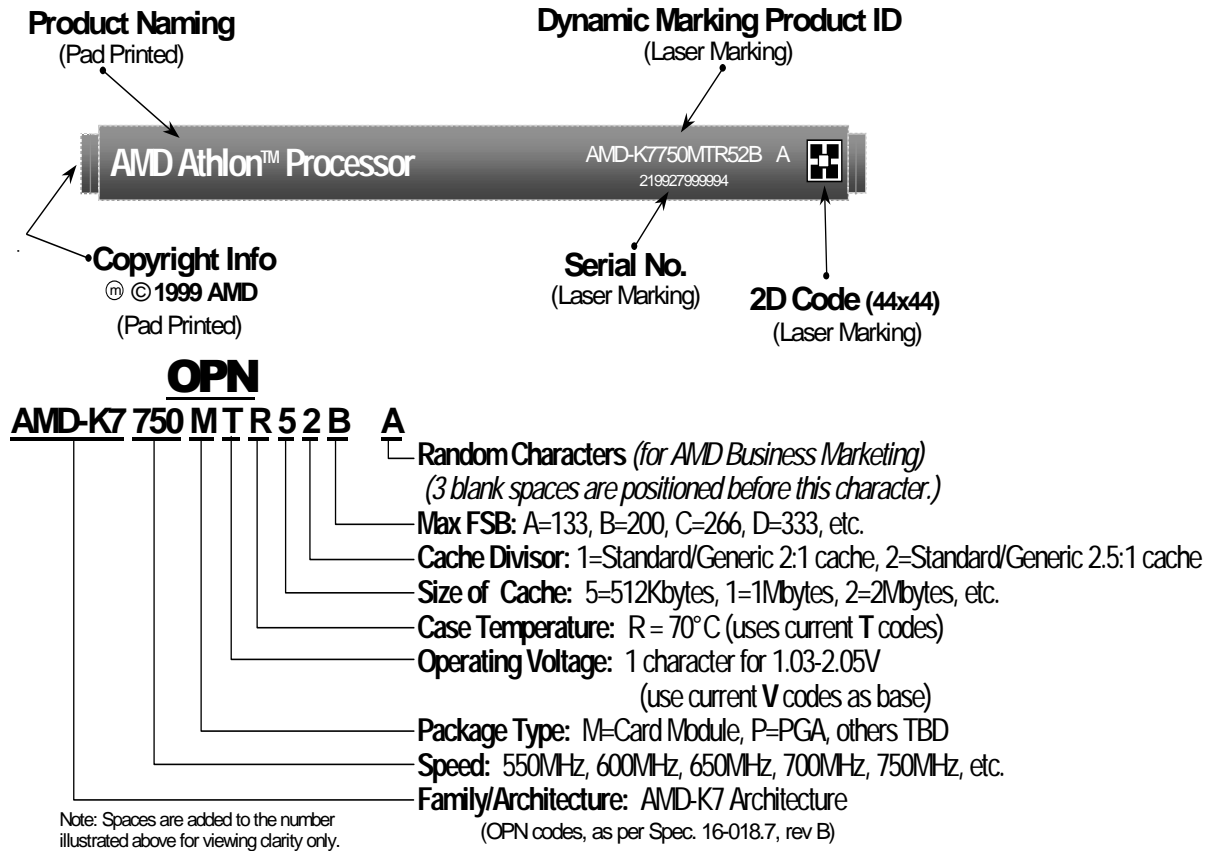

Table 31. Valid Ordering Part Number Combinations

OPN	Package Type	Operating Voltage	Plate Temperature
AMD-K750MTR51B A	Card Module	1.55V–1.65V	0°C–70°C
AMD-K7600MTR51B A	Card Module	1.55V–1.65V	0°C–70°C
AMD-K7650MTR51B A	Card Module	1.55V–1.65V	0°C–70°C
AMD-K7700MTR51B A	Card Module	1.55V–1.65V	0°C–70°C
AMD-K7750MTR52B A	Card Module	1.55V–1.65V	0°C–70°C

Notes:
 This table lists configurations planned to be supported in volume for this device. Consult the local AMD sales office to confirm availability of specific valid combinations and to check on newly-released combinations.

Appendix A

Conventions, Abbreviations, and References

This section contains information about the conventions and abbreviations used in this document and a list of related publications.

Signals and Bits

- **Active-Low Signals**—Signal names containing a pound sign, such as SFILL#, indicate active-Low signals. They are asserted in their Low-voltage state and negated in their High-voltage state. When used in this context, High and Low are written with an initial upper case letter.
- **Signal Ranges**—In a range of signals, the highest and lowest signal numbers are contained in brackets and separated by a colon (for example, D[63:0]).
- **Reserved Bits and Signals**—Signals or bus bits marked *reserved* must be driven inactive or left unconnected, as indicated in the signal descriptions. These bits and signals are reserved by AMD for future implementations. When software reads registers with reserved bits, the reserved bits must be masked. When software writes such registers, it must first read the register and change only the non-reserved bits before writing back to the register.
- **Three-State**—In timing diagrams, signal ranges that are high impedance are shown as a straight horizontal line half-way between the high and low levels.

- Invalid and Don't-Care—In timing diagrams, signal ranges that are invalid or don't-care are filled with a screen pattern.

Data Terminology

The following list defines data terminology:

- Quantities
 - A *word* is two bytes (16 bits)
 - A *doubleword* is four bytes (32 bits)
 - A *quadword* is eight bytes (64 bits)
 - An AMD Athlon™ processor cache line is eight quadwords (64 bytes)
- Addressing—Memory is addressed as a series of bytes on eight-byte (64-bit) boundaries in which each byte can be separately enabled.
- Abbreviations—The following notation is used for bits and bytes:
 - Kilo (K, as in 4-Kbyte page)
 - Mega (M, as in 4 Mbits/sec)
 - Giga (G, as in 4 Gbytes of memory space)

See Table 33 for more abbreviations.

- Little-Endian Convention—The byte with the address *xx...xx00* is in the least-significant byte position (little end). In byte diagrams, bit positions are numbered from right to left—the little end is on the right and the big end is on the left. Data structure diagrams in memory show low addresses at the bottom and high addresses at the top. When data items are aligned, bit notation on a 64-bit data bus maps directly to bit notation in 64-bit-wide memory. Because byte addresses increase from right to left, strings appear in reverse order when illustrated.
- Bit Ranges—In text, bit ranges are shown with a dash (for example, bits 9–1). When accompanied by a signal or bus name, the highest and lowest bit numbers are contained in brackets and separated by a colon (for example, AD[31:0]).
- Bit Values—Bits can either be set to 1 or cleared to 0.
- Hexadecimal and Binary Numbers—Unless the context makes interpretation clear, hexadecimal numbers are followed by an h and binary numbers are followed by a b.

Abbreviations and Acronyms

Table 33 contains the definitions of abbreviations used in this document.

Table 32. Abbreviations

Abbreviation	Meaning
A	Ampere
F	Farad
G	Giga-
Gbit	Gigabit
Gbyte	Gigabyte
H	Henry
h	Hexadecimal
K	Kilo-
Kbyte	Kilobyte
M	Mega-
Mbit	Megabit
Mbyte	Megabyte
MHz	Megahertz
m	Milli-
ms	Millisecond
mW	Milliwatt
μ	Micro-
μA	Microampere
μF	Microfarad
μH	Microhenry
μs	Microsecond
μV	Microvolt
n	nano-
nA	nanoampere
nF	nanofarad
nH	nanohenry
ns	nanosecond
ohm	Ohm
p	pico-
pA	picoampere

Table 32. Abbreviations (continued)

Abbreviation	Meaning
pF	picofarad
pH	picohenry
ps	picosecond
s	Second
V	Volt
W	Watt

Table 33 contains the definitions of acronyms used in this document.

Table 33. Acronyms

Abbreviation	Meaning
ACPI	Advanced Configuration and Power Interface
AGP	Accelerated Graphics Port
APCI	AGP Peripheral Component Interconnect
API	Application Programming Interface
APIC	Advanced Programmable Interrupt Controller
BIOS	Basic Input/Output System
BIST	Built-In Self-Test
BIU	Bus Interface Unit
DDR	Double-Data Rate
DIMM	Dual Inline Memory Module
DMA	Direct Memory Access
DRAM	Direct Random Access Memory
ECC	Error Correcting Code
EIDE	Enhanced Integrated Device Electronics
EISA	Extended Industry Standard Architecture
EPROM	Enhanced Programmable Read Only Memory
EV6	Digital™ Alpha™ Bus
FIFO	First In, First Out
GART	Graphics Address Remapping Table
HSTL	High-Speed Transistor Logic
IDE	Integrated Device Electronics
ISA	Industry Standard Architecture

Table 33. Acronyms (continued)

Abbreviation	Meaning
JEDEC	Joint Electron Device Engineering Council
JTAG	Joint Test Action Group
LAN	Large Area Network
LRU	Least-Recently Used
LVTTTL	Low Voltage Transistor Transistor Logic
MSB	Most Significant Bit
MTRR	Memory Type and Range Registers
MUX	Multiplexer
NMI	Non-Maskable Interrupt
OD	Open Drain
PBGA	Plastic Ball Grid Array
PA	Physical Address
PCI	Peripheral Component Interconnect
PDE	Page Directory Entry
PDT	Page Directory Table
PLL	Phase Locked Loop
PMSM	Power Management State Machine
POS	Power-On Suspend
POST	Power-On Self-Test
RAM	Random Access Memory
ROM	Read Only Memory
RXA	Read Acknowledge Queue
SDI	System DRAM Interface
SDRAM	Synchronous Direct Random Access Memory
SIP	Serial Initialization Packet
SMBus	System Management Bus
SPD	Serial Presence Detect
SRAM	Synchronous Random Access Memory
SROM	Serial Read Only Memory
TLB	Translation Lookaside Buffer
TOM	Top of Memory
TTL	Transistor Transistor Logic
VAS	Virtual Address Space
VPA	Virtual Page Address

Table 33. Acronyms (continued)

Abbreviation	Meaning
VGA	Video Graphics Adapter
USB	Universal Serial Bus
ZDB	Zero Delay Buffer

Related Publications

The following books discuss various aspects of computer architecture that may enhance your understanding of AMD products:

AMD Publications

AMD Athlon™ Processor Technical Brief, order# 22054

AMD Athlon™ Processor Voltage Regulation Application Note, order# 22651

AMD Athlon™ Processor Thermal Application Note, order# 22439

AMD-751™ System Controller Data Sheet, order# 21910

AMD-756™ Peripheral Bus Controller Data Sheet, order# 22548

AMD Processor Recognition Application Note, order# 20734

Websites

Visit the AMD website for documentation of AMD products.

www.amd.com

Other websites of interest include the following:

- JEDEC home page—www.jedec.org
- IEEE home page—www.computer.org
- AGP Forum—www.agpforum.org

