



Product Specification

AHA3410C StarLite™

***25 MBytes/sec Simultaneous Lossless Data
Compression/Decompression Coprocessor IC***

2365 NE Hopkins Court
Pullman, WA 99163-5601
tel: 509.334.1000
fax: 509.334.9000
e-mail: sales@aha.com
www.aha.com



advancedhardwarearchitectures

Notes to Customers

Am29K and Fusion29K are Trademarks of Advanced Micro Devices; i960 and Solutions 960 are Trademarks of Intel Corporation; ColdFIRE is a Trademark of Motorola Corporation.

Table of Contents

1.0 Introduction	1
1.1 Conventions, Notations and Definitions	1
1.2 Features	1
1.3 Functional Overview	2
2.0 System Configuration	3
2.1 Microprocessor Interface	3
3.0 Functional Description	6
3.1 Data Ports	6
3.2 DMA Mode	6
3.3 Pad Word Handling in Burst Mode	9
3.4 DMA Request Signals and Status	9
3.4.1 FIFO Thresholds	9
3.4.2 Request During an End-of-Record	10
3.4.3 Request Status Bits	10
3.5 Data Format	11
3.6 Odd Byte Handling	11
3.6.1 Compression Input and Pad Bytes	11
3.6.2 Compression Output and Pad Bytes	11
3.6.3 Decompression Input, Pad Bytes and Error Checking	11
3.6.4 Decompression Output and Pad Bytes	11
3.7 Video Interfaces	12
3.7.1 Video Input	12
3.7.2 Video Output	12
3.8 Compression Engine	13
3.9 Decompression Engine	13
3.10 Interrupts	13
3.11 Low Power Mode	14
3.12 Test Mode	14
4.0 Register Descriptions	15
4.1 System Configuration 0, Address 0x00 - Read/Write	16
4.2 System Configuration 1, Address 0x01 - Read/Write	17
4.3 Input FIFO Thresholds, Address 0x02 - Read/Write	17
4.4 Output FIFO Thresholds, Address 0x03 - Read/Write	17
4.5 Compression Ports Status, Address 0x04 - Read Only	18
4.6 Decompression Ports Status, Address 0x05 - Read Only	18
4.7 Port Control, Address 0x06 - Read/Write	19
4.8 Interrupt Status/Control, Address 0x07 - Read/Write	19
4.9 Interrupt Mask, Address 0x09 - Read/Write	20
4.10 Version, Address 0x0A - Read Only	20
4.11 Decompression Record Length, Address 0x0C, 0x0D, 0x0E, 0x0F - Read/Write	21
4.12 Record Length, Address 0x10, 0x11, 0x12, 0x13 - Read/Write	21
4.13 Compression Control, Address 0x14 - Read/Write	22
4.14 Compression Reserved, Address 0x15 - Read/Write	22
4.15 Compression Configuration, Address 0x16, 0x17 - Read/Write	22
4.16 Decompression Control, Address 0x18 - Read/Write	23
4.17 Decompression Reserved, Address 0x1A - Read/Write	23
4.18 Decompression Configuration, Address 0x1C, 0x1D - Read/Write	23

5.0 Signal Descriptions 24

 5.1 Microprocessor Interface 24

 5.2 Data Interface 25

 5.3 Video Interface 26

 5.4 System Control 26

6.0 Pinout 27

7.0 DC Electrical Specifications 29

 7.1 Operating Conditions 29

 7.2 Absolute Maximum Stress Ratings 29

8.0 AC Electrical Specifications 31

9.0 Package Specifications 38

10.0 Ordering Information 39

 10.1 Available Parts 39

 10.2 Part Numbering 39

11.0 Related Publications 40

 11.1 AHA Technical Publications 40

 11.2 Other Technical Publications 40

Appendix A: Additional Timing Diagrams for DMA Mode Transfers 41

Figures

Figure 1:	Functional Block Diagram	2
Figure 2:	Microprocessor Port Write (PROCMODE[1:0]="01")	4
Figure 3:	Microprocessor Port Read (PROCMODE[1:0]="01")	4
Figure 4:	Microprocessor Port Write (PROCMODE[1:0]="11")	5
Figure 5:	Microprocessor Port Read (PROCMODE[1:0]="11")	5
Figure 6:	DMA Mode Timing for Single Word Writes, Strobe Condition of DSC=100	7
Figure 7:	DMA Mode Timing for Single Word Reads, Strobe Condition of DSC=100	7
Figure 8:	DMA Mode Timing for Four Word Burst Write, One Wait State, Strobe Condition of DSC=100	7
Figure 9:	DMA Mode Timing for Four Word Burst Read, One Wait State, Strobe Condition of DSC=100	8
Figure 10:	DMA Mode Timing for Eight Word Burst Write, Zero Wait State, Strobe Condition of DSC=100	8
Figure 11:	DMA Mode Timing for Eight Word Burst Read, Zero Wait State, Strobe Condition of DSC=100	8
Figure 12:	FIFO Threshold Example (IFT=4, DSC=2, 1 Word Already in FIFO)	10
Figure 13:	Request vs. End-of-Record, Strobe Condition of DSC=010	10
Figure 14:	Timing Diagram, Video Input	12
Figure 15:	Timing Diagram, Video Output	12
Figure 16:	Pinout	28
Figure 17:	Power vs. Data Rate at 25 MHz Operation	30
Figure 18:	Data Interface Timing	31
Figure 19:	Request Deasserts at EOR, Strobe Condition of DSC=0-3, 6-15; ERC=0	31
Figure 20:	Request Deasserts at EOR, Strobe Condition of DSC=0-3, 6-15; ERC=1	32
Figure 21:	Request Deasserts at EOR, Strobe Condition of DSC=4 or 5; ERC=0	32
Figure 22:	Request Deasserts at EOR, Strobe Condition of DSC=4 or 5; ERC=1	32
Figure 23:	Output Enable Timing	33
Figure 24:	Video Input Port Timing	34
Figure 25:	Video Output Port Timing	34
Figure 26:	Microprocessor Interface Timing (PROCMODE[1]=0)	35
Figure 27:	Microprocessor Interface Timing (PROCMODE[1]=1)	36
Figure 28:	Interrupt Timing	37
Figure 29:	Clock Timing	37
Figure 30:	Power On Reset Timing	37
Figure A1:	DMA Mode Timing for Single Word Writes, Strobe Condition of DSC=000	41
Figure A2:	DMA Mode Timing for Single Word Reads, Strobe Condition of DSC=000	41
Figure A3:	DMA Mode Timing for Four Word Burst Write, One Wait State, Strobe Condition of DSC=000	41
Figure A4:	DMA Mode Timing for Four Word Burst Read, One Wait State, Strobe Condition of DSC=000	42
Figure A5:	DMA Mode Timing for Eight Word Burst Write, Zero Wait State, Strobe Condition of DSC=000	42
Figure A6:	DMA Mode Timing for Eight Word Burst Read, Zero Wait State, Strobe Condition of DSC=000	42
Figure A7:	DMA Mode Timing for Single Word Writes, Strobe Condition of DSC=010	43
Figure A8:	DMA Mode Timing for Single Word Reads, Strobe Condition of DSC=010	43
Figure A9:	DMA Mode Timing for Four Word Burst Write, One Wait State, Strobe Condition of DSC=010	43
Figure A10:	DMA Mode Timing for Four Word Burst Read, One Wait State, Strobe Condition of DSC=010	44
Figure A11:	DMA Mode Timing for Eight Word Burst Write, Zero Wait State, Strobe Condition of DSC=010	44
Figure A12:	DMA Mode Timing for Eight Word Burst Read, Zero Wait State, Strobe Condition of DSC=010	44
Figure A13:	DMA Mode Timing for Single Word Writes, Strobe Condition of DSC=011	45
Figure A14:	DMA Mode Timing for Single Word Reads, Strobe Condition of DSC=011	45
Figure A15:	DMA Mode Timing for Four Word Burst Write, One Wait State, Strobe Condition of DSC=011	45
Figure A16:	DMA Mode Timing for Four Word Burst Read, One Wait State, Strobe Condition of DSC=011	46
Figure A17:	DMA Mode Timing for Eight Word Burst Write, Zero Wait State, Strobe Condition of DSC=011	46
Figure A18:	DMA Mode Timing for Eight Word Burst Read, Zero Wait State, Strobe Condition of DSC=011	46
Figure A19:	DMA Mode Timing for Single Word Writes, Strobe Condition of DSC=111	47
Figure A20:	DMA Mode Timing for Single Word Reads, Strobe Condition of DSC=111	47

Tables

Table 1:	<i>Data Bus and FIFO Sizes Supported by StarLite™</i>	2
Table 2:	<i>StarLite™ Connection to Host Microprocessors</i>	3
Table 3:	<i>Microprocessor Port Configuration</i>	4
Table 4:	<i>Internal Strobe Conditions for DMA Mode</i>	6
Table 5:	<i>Internal Registers</i>	15
Table 6:	<i>Data Port Timing Requirements</i>	31
Table 7:	<i>Request vs. EOR Timing</i>	33
Table 8:	<i>Output Enable Timing Requirements</i>	33
Table 9:	<i>Video Input Port Timing Requirements</i>	34
Table 10:	<i>Video Output Port Timing Requirements</i>	34
Table 11:	<i>Microprocessor Interface Timing Requirements</i>	36
Table 12:	<i>Interrupt Timing Requirements</i>	37
Table 13:	<i>Clock Timing Requirements</i>	37
Table 14:	<i>Power On Reset Timing Requirements</i>	37

1.0 INTRODUCTION

StarLite™ is a single chip CMOS VLSI coprocessor device that implements a lossless compression and decompression algorithm. The algorithm exhibits an average compression ratio over 13 to 1 for bitmap image data. The device supports simultaneous compression and decompression operations at 25 MBytes/sec each.

The device interfaces directly to various RISC and CISC processors from AMD, Intel and Motorola. Compression and decompression data transfers normally occur over a high speed bidirectional 32-bit data bus capable of up to 100 MBytes/sec synchronous data rates. Two 8-bit synchronous video data ports provide ability to optionally interface to scanner and print engine respectively for applications such as multifunction laser printers and copiers.

A low power mode is achieved by stopping all data transfers and the clock signal. All outputs may be tristated to facilitate board level testing.

This document contains functional description, system configurations, register descriptions and timing diagrams. It is intended for system designers considering a compression coprocessor in their embedded applications. Software simulation and an analysis of the algorithm for printer and copier images of various complexity are also available for evaluation. A comprehensive Designer's Guide complementing this document is also available from AHA to assist with the system design. Section 11.0 contains a list of related technical publications.

1.1 CONVENTIONS, NOTATIONS AND DEFINITIONS

- Active low signals have an “N” appended to the end of the signal name. For example, CSN and RDYN.
- A “bar” over a signal name indicates an inverse of the signal. For example, \overline{SD} indicates an inverse of SD. This terminology is used only in logic equations.
- “Signal assertion” means the output signal is logically true.
- Hex values are represented with a prefix of “0x”, such as Register “0x00”. Binary values do not contain a prefix, for example, DSC=000.
- A range of signal names or register bits is denoted by a set of colons between the numbers. Most significant bit is always shown first, followed by least significant bit. For example, VOD[7:0] indicates signal names VOD7 through VOD0.
- A logical “AND” function of two signals is expressed with an “&” between variables.

- Mega Bytes per second is referred to as MBytes/sec or MB/sec.
- In referencing microprocessors, an x or xx is used as suffix to indicate more than one processor. For example, Am290xx processor family includes the Am29000, 29005, 29030 and 29035.
- Reserved bits in registers are referred as “res”.
- REQN or ACKN refer to either CI, DI, CO or DO Request or Acknowledge signals, as applicable.

1.2 FEATURES

PERFORMANCE:

- 25 MB/sec compression and decompression rates
- 100 MB/sec burst data rate over a 32-bit data bus
- 25 MB/sec synchronous 8-bit video in and video out ports
- Simultaneous compression and decompression operation at full bandwidth
- Average 13 to 1 compression performance for bitmap image data

FLEXIBILITY:

- Configurable I/O interface for DMA mode; Big Endian or Little Endian; and 32-bit or 16-bit bus widths
- Interfaces directly with Am29K or i960 family of RISC processors and Motorola 68xxx CISC processors
- Optional 8-bit video input and output ports
- Pass-through mode passes raw data through compression and decompression engines
- Optional counter enables error checking in decompression operation

SYSTEM INTERFACE:

- Single chip compression and decompression solution
- No external SRAM required
- Four 16 × 32-bit FIFOs
- Programmable interrupts
- 25 MHz maximum clock frequency
- Output signals may be tristated to facilitate board level testing

OTHERS:

- Low power modes
- Software emulation program available
- 120 pin quad flat package

Figure 1: Functional Block Diagram

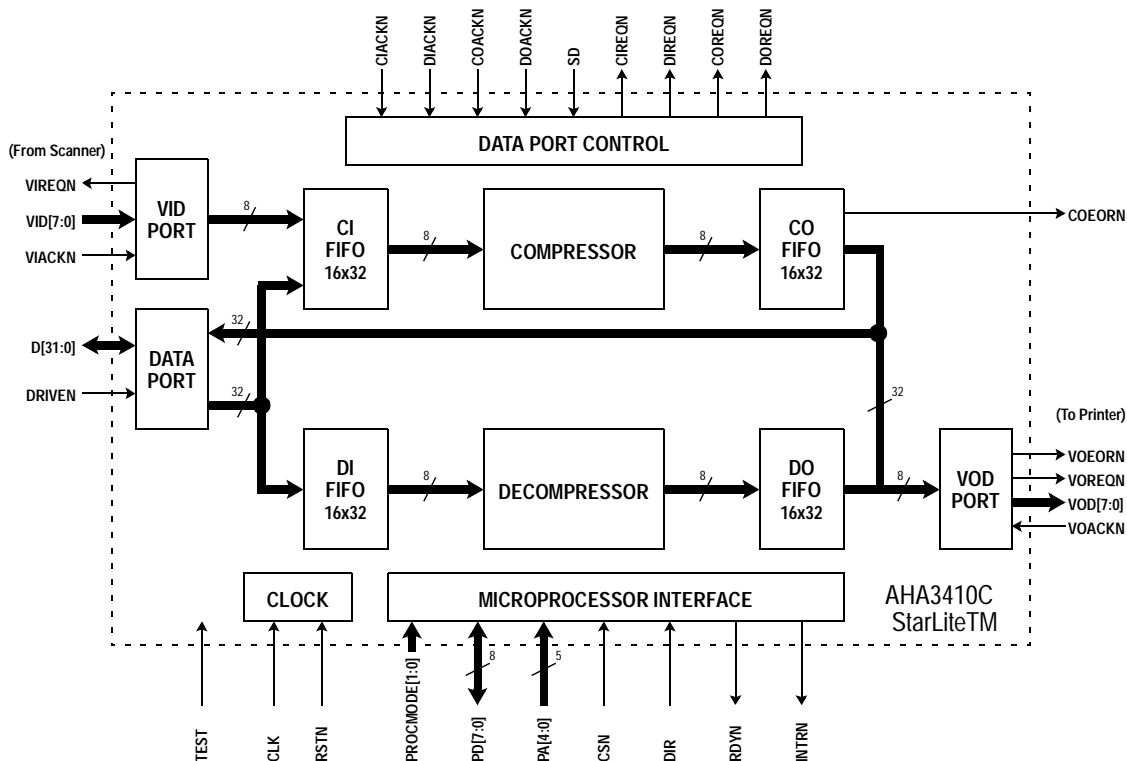

1.3 FUNCTIONAL OVERVIEW

The coprocessor device has three external high speed synchronous data ports capable of transferring once every 25 MHz clock. These are a 32-bit bidirectional data port, an 8-bit Video Input Data (VID) port and a Video Output Data (VOD) port. The 32-bit port is capable of transferring up to 100 MBytes/sec. The VID and VOD are capable of up to 25 MBytes/sec each.

The device accepts uncompressed data through the 8-bit VID port or the 32-bit data port into its Compression In FIFO (CI FIFO). The 32-bit data port may be configured for 16-bit transfers. Compressed data is available through the 32-bit data port via the Compressed Output FIFO (CO

FIFO). The sustained data rate through the compression engine is 25 MBytes/sec.

Decompression data may be simultaneously processed by the device. Decompression data is accepted through the 32-bit data port, buffered in the Decompression Input FIFO (DI FIFO) and decompressed. The output data is made available on the 32-bit data port via the Decompression Output FIFO (DO FIFO) or the 8-bit Video Output port. The decompression engine runs on the 25 MHz clock and is capable of processing an uncompressed byte every clock, i.e., 25 MB/sec.

The four FIFOs are organized as 16 × 32 each. For data transfers through the three ports, the “effective” FIFO sizes differ according to their data bus widths. The table below shows the size of the data port and the “effective” FIFO size for the various configurations supported by the device.

Table 1: Data Bus and FIFO Sizes Supported by StarLite™

<i>OPERATION</i>	<i>DATA BUS WIDTH</i>	<i>PORT</i>	<i>EFFECTIVE FIFO SIZE</i>
Compression Data In	8	Video In	16 × 8
Compression Data In/Out	32	Data Port	16 × 32
Compression Data In/Out	16	Data Port	16 × 16
Decompression Data In/Out	32	Data Port	16 × 32
Decompression Data In/Out	16	Data Port	16 × 16
Decompressed Data Out	8	Video Out	16 × 8

Table 2: StarLite™ Connection to Host Microprocessors

PIN NAME	Am290xx	Am292xx	i960Cx	i960Kx
PA	A	A	A	LAD
CSN	CS	PIACS	CS	CS
DIR	R/W	R/W	W/R	W/R
PD	D	ID	D	LAD
SD	VDD	VDD	WAIT	READY
RDYN	DRDY	No Connect	No Connect	READY
DRIVEN	System Dependent	PIAOE	DEN	System Dependent
CLOCK	SYSCLK	MEMCLK	PCLK	No Connect

Movement of data for compression or decompression is performed using synchronous DMA over the 32-bit data port. The Video ports support synchronous DMA mode transfers. The DMA strobe conditions are configurable for the 32-bit data port depending upon the RISC processor of the system and the DMA controller available.

Data transfer for compression or decompression is synchronous over the three data ports functioning as DMA masters. To initiate a transfer into or out of the Video ports, the device asserts VxREQN, the external device responds with VxACKN and begins to transfer data over the VID or VOD busses on each succeeding rising edge of the clock until VxREQN is deasserted. The 32-bit port relies on the FIFO Threshold settings to determine the transfer.

The sections below describe the various configurations, programming and other special considerations in developing a compression system using StarLite™.

2.0 SYSTEM CONFIGURATION

This section provides information on connecting StarLite™ to various microprocessors in DMA mode.

2.1 MICROPROCESSOR INTERFACE

The device is capable of interfacing directly to various processors for embedded application. The table below shows how StarLite™ should be connected to various host microprocessors.

All register accesses to StarLite™ are performed on the 8-bit PD bus. The PD bus is the lowest byte of the 32-bit microprocessor bus. During reads of the internal registers, the upper 24 bits are not driven. System designers should terminate these lines with Pullup resistors.

StarLite™ provides four modes of operation for the microprocessor port. Both active high and active low write enable signals are allowed as well as two modes for chip select. The mode of operation is set by

the PROCMODE[1:0] pins. The PROCMODE[1] signal selects when CSN must be active and also how long an access lasts.

When PROCMODE[1] is high, CSN determines the length of the access. CSN must be at least 5 clocks in length. On a read, valid data is driven onto PD[7:0] during the 5th clock. If CSN is longer than 5 clocks, then valid data continues to be driven out onto PD[7:0]. When CSN goes inactive (high), PD[7:0] goes tristate (asynchronously) and RDYN is driven high asynchronously. CSN must be high for at least two clocks. RDYN is always driven (it is not tristated when PROCMODE[1] is high). The mode is typical of processors such as the Motorola 68xxx.

When PROCMODE[1] is low, accesses are fixed at 5 clocks, PD[7:0] is only driven during the fifth clock, and RDYN is driven high for the first 4 clocks and low during the fifth clock. RDYN is tristated at all other times. Write data must be driven the clock after CSN is sampled low. Accesses may be back to back with no delays in between. This mode is typical of RISC processors such as the i960 and Am29K.

PROCMODE[0] determines the polarity of the DIR pin. If PROCMODE[0] is high, then the DIR pin is an active low write enable. If PROCMODE[0] is low, then the DIR pin is an active high write enable. Figure 2 through Figure 5 illustrate the detailed timing diagrams for the microprocessor interface.

For additional notes on interfacing to various microprocessors, refer to AHA Application Note (ANDC12), *StarLite™ Designer's Guide*.

Table 3: Microprocessor Port Configuration

<i>PROCMODE[1:0]</i>	<i>DIR</i>	<i>CYCLE LENGTH</i>	<i>EXAMPLE PROCESSOR</i>
00	Active high write	fixed	i960
01	Active low write	fixed	Am29K
10	Active high write	variable	
11	Active low write	variable	68xxx

Figure 2: Microprocessor Port Write (PROCMODE[1:0]="01")

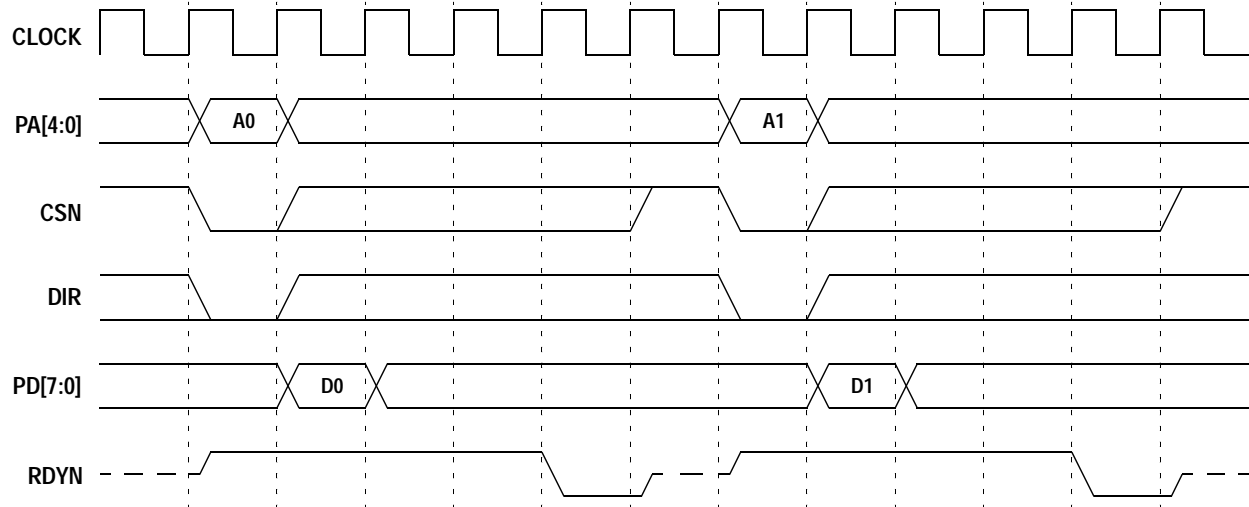

Figure 3: Microprocessor Port Read (PROCMODE[1:0]="01")

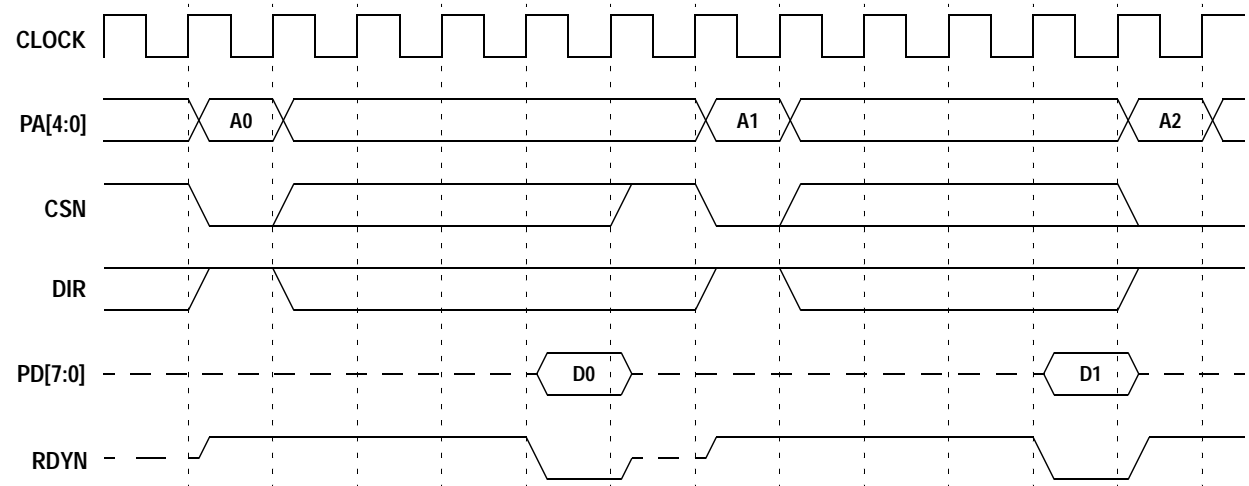

Figure 4: Microprocessor Port Write (PROCMODE[1:0]="11")

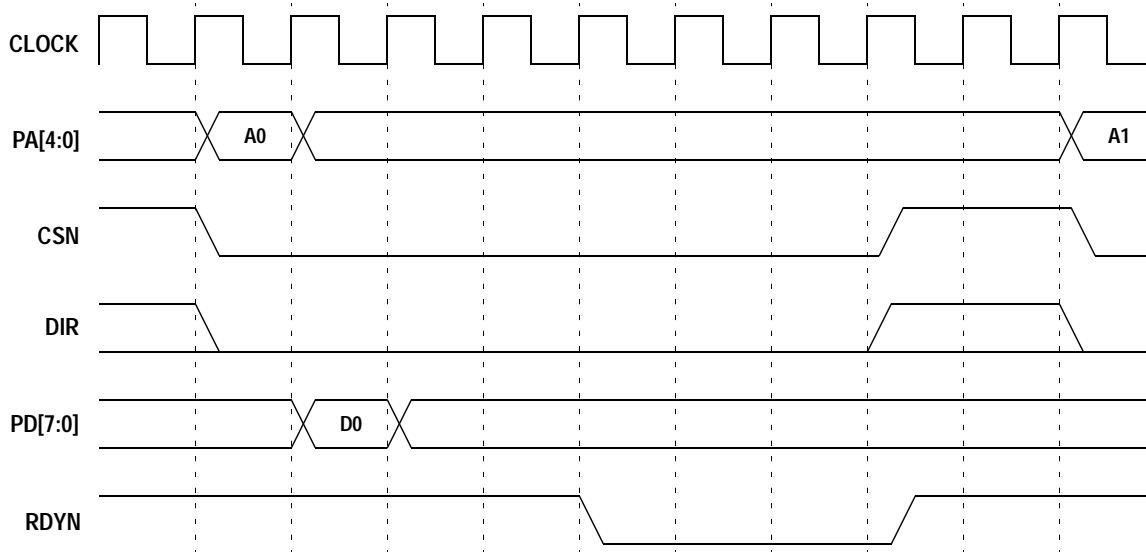
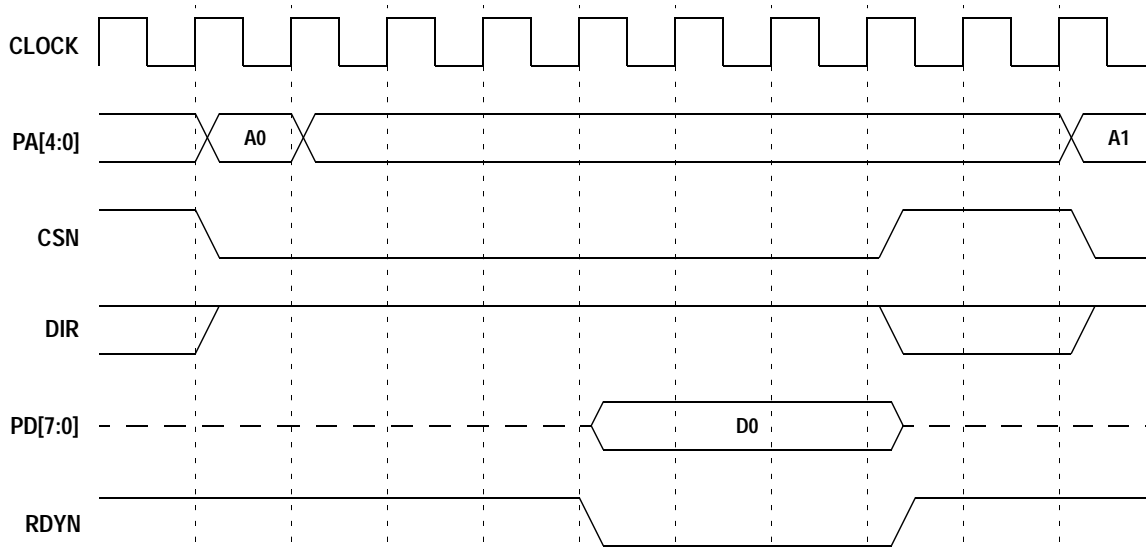

Figure 5: Microprocessor Port Read (PROCMODE[1:0]="11")



3.0 FUNCTIONAL DESCRIPTION

This section describes the various data ports, special handling, data formats and clocking structure.

3.1 DATA PORTS

StarLite™ contains two data input ports, CI and DI, and two data output ports, CO and DO on the same 32-bit data bus, D[31:0]. Data transfers can be controlled by an external DMA control. The logical conditions under which data is written to the input FIFOs or read from the output FIFOs are set by the DSC (Data Strobe Condition) field of the *System Configuration 1* register.

A strobe condition defines under what logical conditions the input FIFOs are written or the output FIFOs read. CIACKN, COACKN, DIACKN, DOACKN, and SD pins combine to strobe data in a manner similar to DMA controllers. The DMA Mode sub-section describes the various data strobe options.

3.2 DMA MODE

DMA data strobes are indicated by setting the most significant bit of the data strobe condition to zero (DSC[3]=0).

On the rising edge of CLOCK when the strobe condition is met, the port with the active acknowledge either strobes data into or out of the chip. No more than one port may assert acknowledge at any one time. Table 4 shows the various conditions that may be programmed into register DSC.

Figure 6 through Figure 11 illustrate the DMA mode timings for single, four word and eight word burst transfers for DSC=100 selection. For other DSC settings, please refer to Appendix A. Note that the only difference between odd and even values of DSC is the polarity of SD. Waveforms are only shown for polarities of SD corresponding to specific systems.

Table 4: Internal Strobe Conditions for DMA Mode

<i>DSC[3:0]</i>	<i>LOGIC EQUATION</i>	<i>SYSTEM CONFIGURATION</i>
0000	$(\overline{ACKN}) \& (\overline{ACKN_{delayed}}) \& (SD)$	i960Cx with internal DMA controller. SD is connected to WAITN.
0001	$(\overline{ACKN}) \& (\overline{ACKN_{delayed}}) \& (\overline{SD})$	No specific system
0010	$(\overline{ACKN}) \& (SD)$	General purpose DMA controller
0011	$(\overline{ACKN}) \& (\overline{SD})$	i960Kx or Am290xx with external, bus master type DMA controller. SD is connected to RDYN.
0100	$(\overline{ACKN_{delayed}}) \& (SD_{delayed})$	Am2924x with internal DMA controller
0101	$(\overline{ACKN_{delayed}}) \& (\overline{SD_{delayed}})$	No specific system
0110	$(ACKN) \& (\overline{ACKN_{delayed}})$	Am2920x with internal DMA controller
0111	$(ACKN) \& (ACKN_{delayed})$	Am2920x with internal DMA controller

$ACKN_{delayed} = ACKN$ delayed 1 clock

$SD_{delayed} = SD$ delayed 1 clock

Figure 6: DMA Mode Timing for Single Word Writes, Strobe Condition of DSC=100

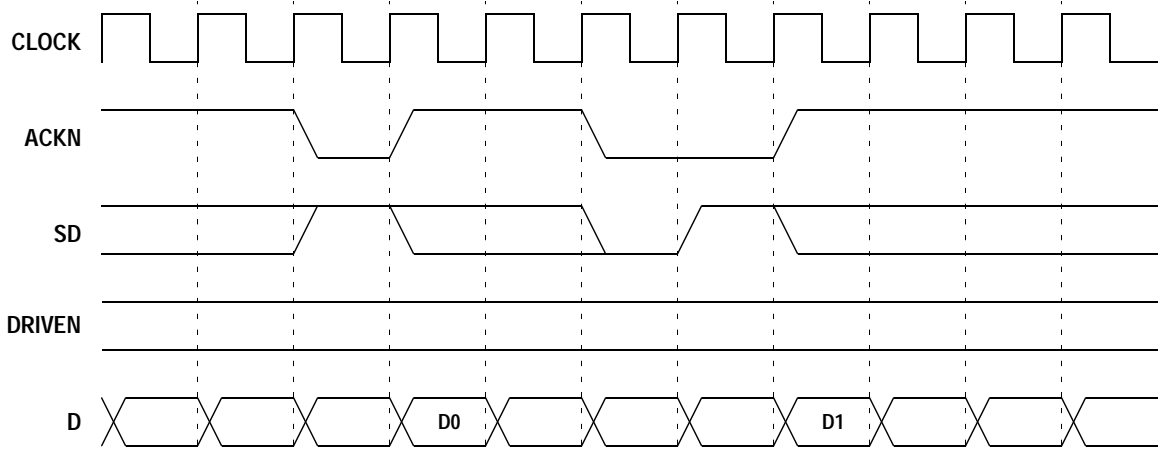

Figure 7: DMA Mode Timing for Single Word Reads, Strobe Condition of DSC=100

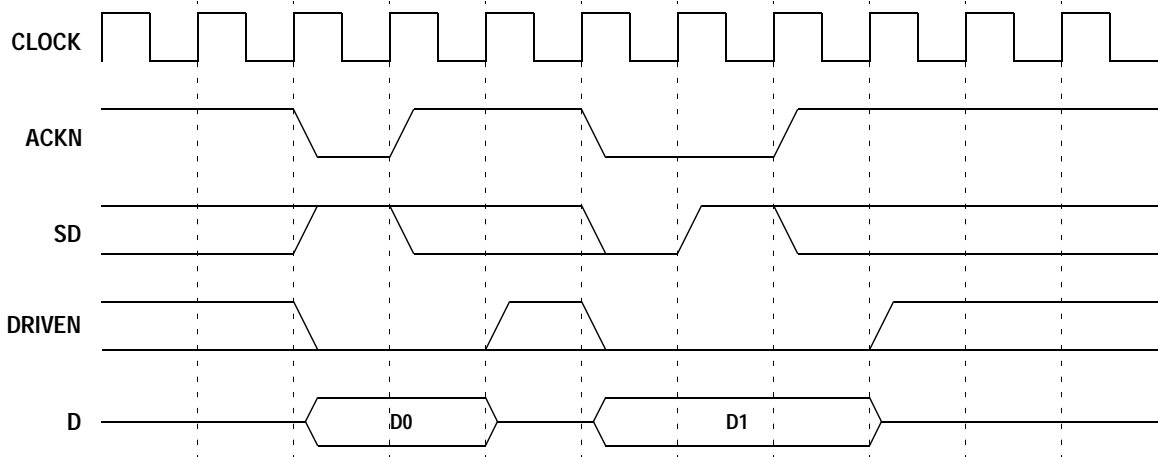

Figure 8: DMA Mode Timing for Four Word Burst Write, One Wait State, Strobe Condition of DSC=100

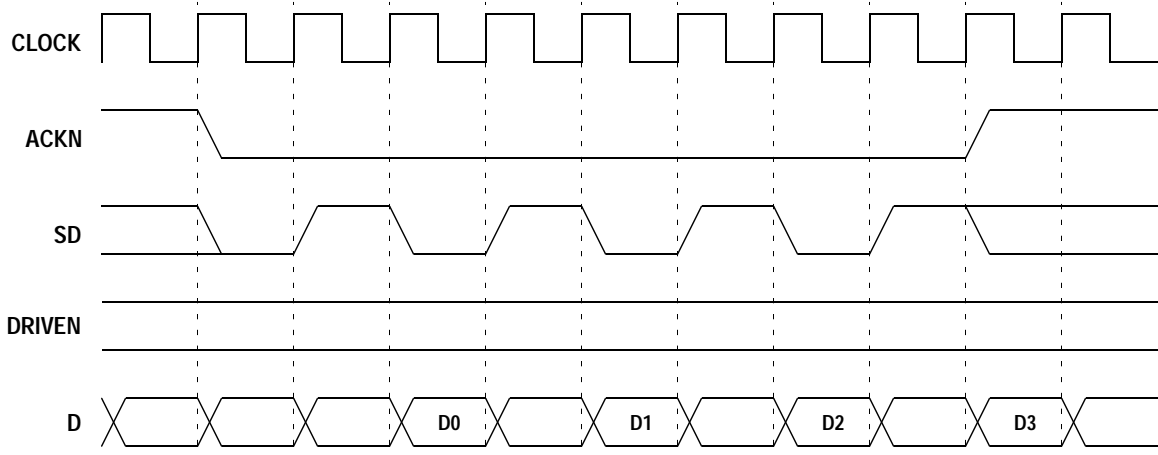

Figure 9: DMA Mode Timing for Four Word Burst Read, One Wait State, Strobe Condition of DSC=100

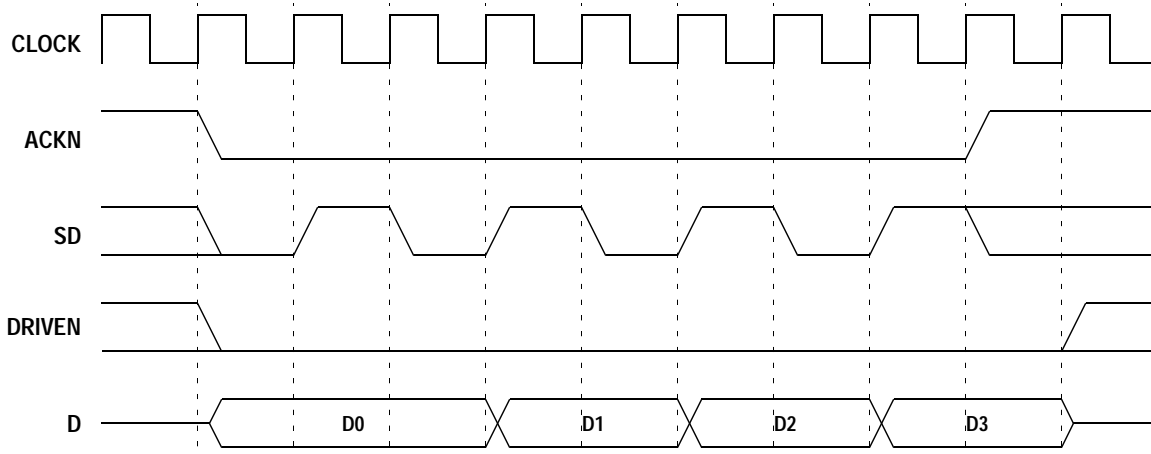

Figure 10: DMA Mode Timing for Eight Word Burst Write, Zero Wait State, Strobe Condition of DSC=100

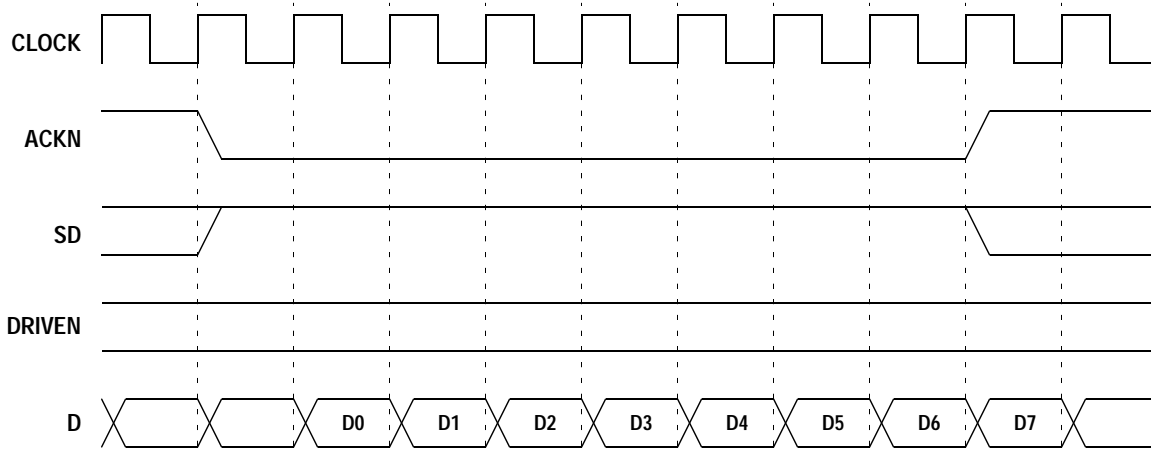
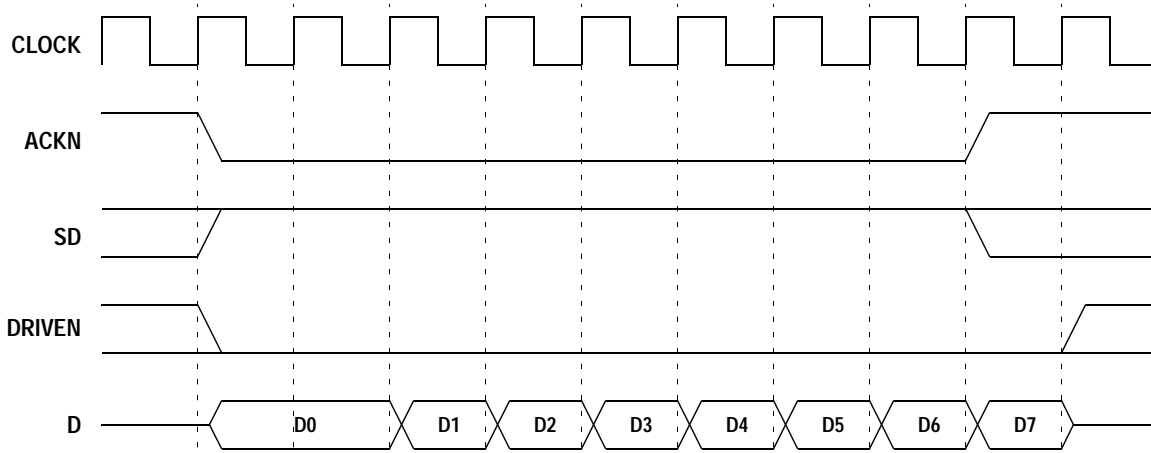

Figure 11: DMA Mode Timing for Eight Word Burst Read, Zero Wait State, Strobe Condition of DSC=100



3.3 PAD WORD HANDLING IN BURST MODE

If a word containing an End-of-Record comes out during a burst read, the words after the End-of-Record are invalid (pad) words. This prevents a burst read from crossing record boundaries. The first word of the next burst read is the first word of the next record. The pad words must be deleted during decompression by using the Decompression Pause on Record Boundaries bit (DPOR), in the *Decompression Control* register. After the part is paused, the DI FIFO must be reset by asserting the DIRST bit in the *Port Control* register. Decompressor must also be reset by asserting DDR bit in *Decompression Control* register.

The COEORN signal is asserted when an End-of-Record is present on the output of the CO FIFO. COEORN is active while the EOR is strobed out. In some systems COEORN can be used to generate a DMA-done condition.

3.4 DMA REQUEST SIGNALS AND STATUS

StarLite™ requests data using request pins (CIREQN, DIREQN, COREQN, DOREQN). The requests are controlled by programmable FIFO thresholds. Both input and output FIFOs have programmable empty and full thresholds set in the *Input FIFO Threshold* and *Output FIFO Threshold* registers. By requesting only when a FIFO can sustain a certain burst size, the bus is used more efficiently.

The input requests, CIREQN and DIREQN, operate under the following prioritized rules:

- 1) If the FIFO reset in the *Port Control* register is active, the request is inactive.
- 2) If a FIFO overflow interrupt is active, the request is inactive.
- 3) If the FIFO is at or below the empty threshold, the request will go active.
- 4) If the FIFO is at or above the full threshold, the request will go inactive.

The output requests, COREQN and DOREQN, operate under the following prioritized rules:

- 1) If the FIFO reset in the *Port Control* register is active, the request is inactive.
- 2) If the output FIFO underflow interrupt is active, the request is inactive.
- 3) If an EOR is present in the output FIFO, the request will go active.
- 4) If the output FIFO is at or above the full threshold, the request will go active.

- 5) If an EOR is read (strobed) out of the FIFO, the request will go inactive during the same clock as the strobe (if ERC=0), otherwise it will go inactive on the next clock.
- 6) If the output FIFO is at or below the empty threshold, the request will go inactive.

3.4.1 FIFO THRESHOLDS

For maximum efficiency, the FIFO thresholds should be set in such a way that the compressor seldom runs out of data from the CI FIFO or completely fills the output FIFO. The FIFOs are 16 words deep.

For example, in a system with fixed 8-word bursts, good values for the thresholds are:

$$\text{IET}=3, \text{IFT}=4, \quad \text{OFT}=\text{D}, \text{OET}=\text{C}$$

Setting the input full threshold to one higher than the input empty threshold simply guarantees that the request will deassert as soon as possible. The latency between a word being strobed in and the request changing due to a FIFO threshold condition is 3 clocks. This should be kept in mind when programming threshold values. Refer to AHA Application Note (ANDC12), *StarLite™ Designer's Guide* for a more thorough discussion of FIFO thresholds. The following figure shows an example of an input FIFO crossing its full threshold.

Figure 12: FIFO Threshold Example (IFT=4, DSC=2, 1 Word Already in FIFO)

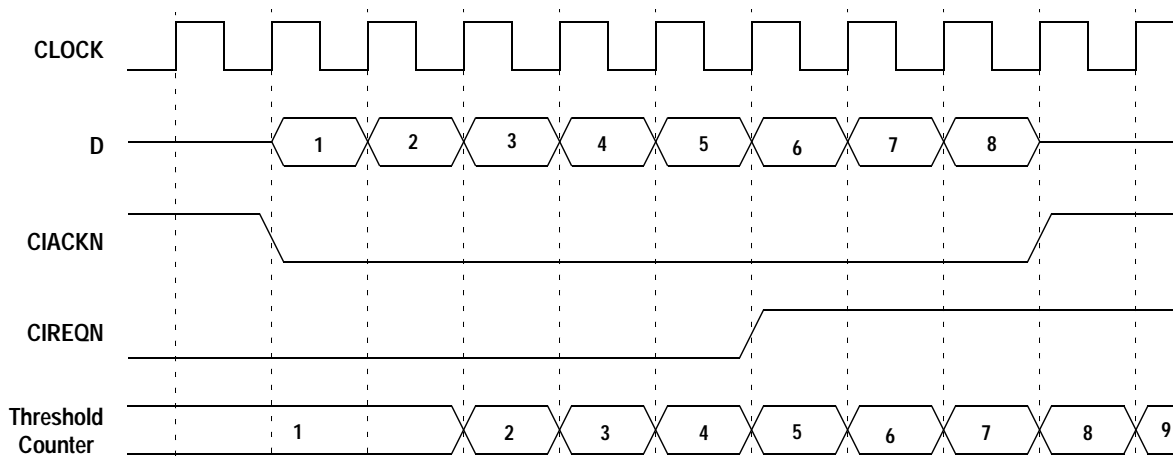

Note: CIREQN deasserted when threshold counter exceeded IFT=4.

Figure 13: Request vs. End-of-Record, Strobe Condition of DSC=010

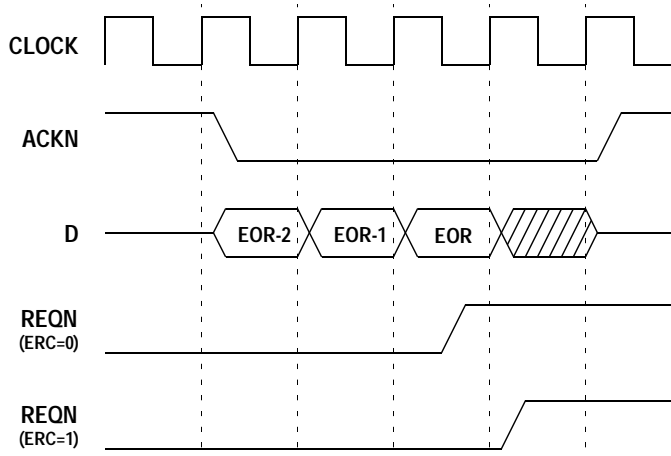

3.4.2 REQUEST DURING AN END-OF-RECORD

The request deasserts at an EOR in one of two ways. If ERC bit in *System Configuration 1* is '0', the request will deassert asynchronously during the clock where the EOR is strobed out of the FIFO. This leads to a long output delay for REQN, but may be necessary in some systems. For DSC values of 4 or 5, the request deasserts the first clock after the acknowledge pulse for the EOR. If ERC is set to '1', then the request deasserts synchronously the clock after the EOR is strobed out. The minimum low time on the request in this case is one clock.

The request delay varies between the different strobe conditions. See the timing section for further details.

3.4.3 REQUEST STATUS BITS

An external microprocessor can also read the value of each request using the CIREQ and COREQ bits in the *Compression Port Status* register and the DIREQ and DOREQ bits in the *Decompression Port Status* register. Please note that the request status bits are active high while the pins are active low.

3.5 DATA FORMAT

The width of the D bus is selected with the WIDE bit in *System Configuration 0*. If WIDE=1, then D is a 32-bit bus. If WIDE=0, D is a 16-bit bus. If the bus is configured to be 16-bits wide (WIDE=0), all data transfers occur on D[15:0] and the upper 16 bits of the bus, D[31:16], should be terminated with Pullup resistors. If WIDE=0, the FIFO is sixteen words deep.

Since the compression algorithm is byte oriented, it is necessary for StarLite™ to know the ordering of the bytes within the word. The BIG bit in *System Configuration 0* selects between big endian and little endian byte ordering. Little endian stores the first byte in the lower eight bits of a word (D[7:0]). Big endian stores the first byte in the uppermost eight bits of a word (D[31:24] for WIDE=1, D[15:8] for WIDE=0).

3.6 ODD BYTE HANDLING

All data transfers to or from either the compression or decompression engines are performed on the D bus on word boundaries. Since no provision is made for single byte transfers, occasionally words will contain pad bytes. Following is a description of when these pad bytes are necessary for each of the data interfaces.

3.6.1 COMPRESSION INPUT AND PAD BYTES

Uncompressed data input into StarLite™ is treated as records. The length of these records is fixed by the value in the *Record Length* or RLEN register. This register contains the number of uncompressed bytes in each record. If the value in RLEN is not an integer multiple of number of bytes per word as selected by WIDE, the final word in the transfer of the record will contain pad bytes which are discarded and have no effect on either the dictionary or the output data stream. The next record must begin on a word boundary.

The minimum value for RLEN is 4.

3.6.2 COMPRESSION OUTPUT AND PAD BYTES

If a record ends on a byte other than the last byte in a word, the final word will contain 1, 2 or 3 pad bytes. The pad bytes have a value of 0x00.

3.6.3 DECOMPRESSION INPUT, PAD BYTES AND ERROR CHECKING

This port recognizes the end of a record by the appearance of a special End-of-Record sequence in the data stream. Once this is seen, the remaining bytes in the current word are treated as pad bytes and discarded. The word following the end of the record is the beginning of the next record.

When operating in decompression mode, the *Decompression Record Length* (DRLEN) register can be used to provide error checking. The expected length of the decompressed record is programmed into the DRLEN register. The decompressor then counts down from the value in DRLEN to '0'.

A DERR interrupt is issued if an EOR is not read out of the decompressor when the counter expires or if an EOR occurs before the counter expires (i.e., when the record lengths do not match). If the DERR interrupt is masked, use of the DRLEN register is optional.

When operating in pass-through mode, there is no End-of-Record codeword for the decompressor to see. In pass-through mode, the user must set the record length in the DRLEN register.

3.6.4 DECOMPRESSION OUTPUT AND PAD BYTES

When the decompressor detects an End-of-Record codeword, it will add enough pad bytes of value 0x00 to complete the current word.

3.7 VIDEO INTERFACES

3.7.1 VIDEO INPUT

The video input port is enabled by the VDIE bit in the *System Configuration 1* register. The port uses VIREQN to indicate that the port can accept another byte. The value on VID[7:0] is written into StarLite™ each clock that VIREQN and VIACKN are both low.

The video input port asserts VIREQN whenever there is room in the CI FIFO. The values in IET and IFT are all ignored. The compression input FIFO is 16 bytes deep in this mode. The video input port can transfer up to one byte per clock (25 MB/sec). The DMA interface cannot access the compression input FIFO when VDIE is set.

3.7.2 VIDEO OUTPUT

The video output port is enabled by the VDOE bit in the *System Configuration 1* register. The port uses VOREQN to indicate that the byte on VOD[7:0] is valid. An 8-bit word is read each clock when both VOREQN and VOACKN are sampled low on a rising edge of CLOCK. Pad bytes at an end of record are discarded by the video output port and do not appear on VOD[7:0]. When the byte on VOD[7:0] is the last byte in a record, the VOEORN signal will go low. VOEORN is active while an EOR is read out. Unlike a DMA transfer, there are no pad bytes after an End-of-Record.

The port requests whenever a valid byte is present on the output. The values in OET and OFT are all ignored. The decompression output FIFO is 16 bytes deep in this mode. The video output port can output up to one byte per clock (25 MB/sec). The DMA interface cannot access the decompression output FIFO when VDOE is set.

Figure 14: Timing Diagram, Video Input

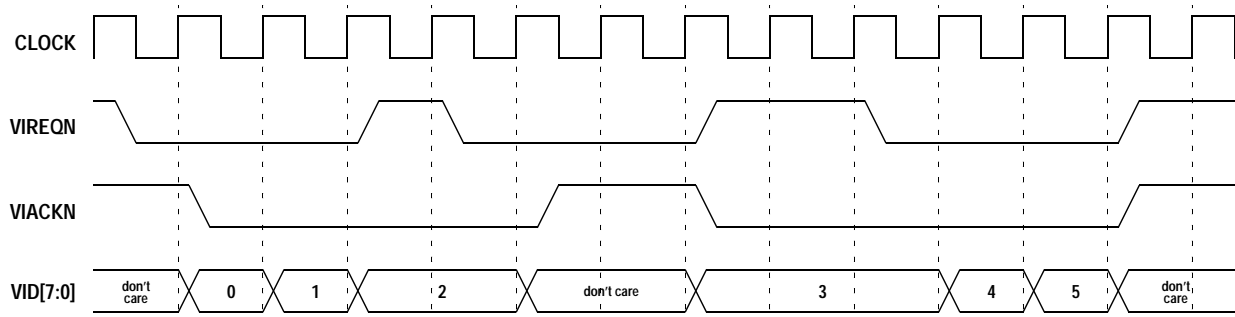
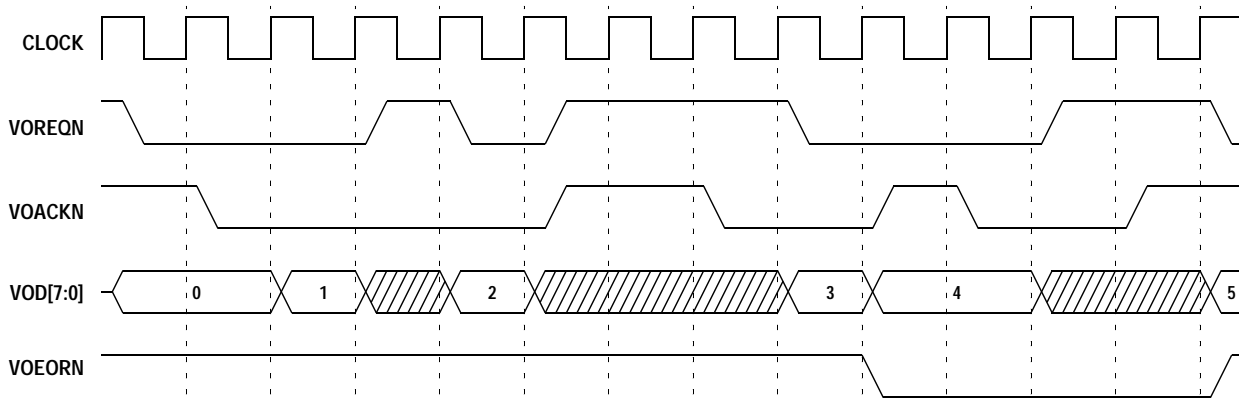

Figure 15: Timing Diagram, Video Output



3.8 COMPRESSION ENGINE

The compression engine supports either compression or pass-through processes. The compression engine is enabled with the COMP bit in the *Compression Control* register. When the engine is enabled, it takes data from the CI FIFO as it becomes available. This data is either compressed by the engine or passed through unaltered. This pass-through mode is selected with the CPASS bit in the *Compression Control* register. The CPASS bit may only be changed when COMP is set to '0'. The contents of the dictionary are preserved when COMP is changed. However, when CPASS is changed, the contents are lost. Consequently, StarLite™ can not be changed from pass-through mode to compression mode or vice versa without losing the contents of the dictionary.

The compressor can be instructed to halt input at the end of each record. If the CPOR bit is set, the compressor will stop taking bytes out of the CI FIFO immediately after the last byte of a record. In addition, the COMP bit will be cleared. The CEMP bit will then indicate when all of the data has left the compressor. Compression is restarted by setting the COMP bit.

The compression engine takes data from the compression input FIFO at a maximum rate of 25 MBytes/sec. Two conditions cause the data rate to drop below the maximum. The first is caused by the compression input FIFO running empty of data to be compressed. The second condition is caused by the output FIFO filling. When this occurs, the engine halts and waits for the FIFO. While halted, the engine goes into a low power standby mode. Refer to the table in Section 7.1 for the extent of power savings.

3.9 DECOMPRESSION ENGINE

The decompression engine is enabled with the DCOMP bit in the *Decompression Control* register. When the engine is enabled, it takes data from the DI FIFO as it becomes available. This data is either decompressed by the engine or passed through unaltered. Pass-through mode is selected with the DPASS bit. DPASS may only be changed when DCOMP is set to '0' and DEMP is set to '1'. The contents of the dictionary are preserved when DCOMP is changed. However, when DPASS is changed, the contents are lost. Consequently, StarLite™ can not be changed from pass-through mode to decompression mode or vice versa without losing the contents of the dictionary.

The decompressor can be instructed to halt operation at the end of each record. If the DPOR bit is set, the decompressor will stop processing

additional data after it decodes an End-of-Record and DCOMP will be cleared. If DPOR is set and data from a second record enters the FIFO immediately after the first record, bytes from the second record will have entered the decompressor prior to decoding the EOR. An implication of this is that bytes from the second record will remain in the decompressor and prevent DEMP from setting after all of the data from the first record has left the decompressor. This differs from operation of the compression engine. In either mode, a DOEOR interrupt is generated when the last byte of a compressed record is read out of the chip.

The decompressor takes data from the decompression input FIFO at a maximum rate of 25 MBytes/sec. StarLite™ can maintain this data rate as long as the decompression input FIFO is not empty or the decompression output FIFO is not full.

3.10 INTERRUPTS

Seven conditions are reported in the *Interrupt Status/Control* register as individual bits. All interrupts are maskable by setting the corresponding bits in the *Interrupt Mask* register. A '1' in the *Interrupt Mask* register means the corresponding bit in the *Interrupt Status/Control* register is masked and does not affect the interrupt pin (INTRN). The INTRN pin is active whenever any unmasked interrupt bit is set to a '1'.

End-of-Record interrupts are posted when a word containing an end-of-record is strobed out of the compression or decompression output FIFOs (CEOR and DEOR respectively). A DEOR interrupt is also reported if an end-of-record is read from the video output port.

Four FIFO error conditions are also reported. Overflowing the input FIFOs generates a CIOF or DIOF interrupt. An overflow can only be cleared by resetting the respective FIFO via the *Port Control* register.

Underflowing the output FIFOs (reading when they are not ready) generates a COUF or DOUF. Underflow interrupts are cleared by writing a '1' to COUF or DOUF. In the event of an underflow, the respective FIFO must be reset. Note that in systems using fixed length bursts which re-arbitrate during a burst, the CO FIFO may request another burst when the record actually finishes near the end of the current burst. In this scenario a second burst takes place causing a FIFO underflow. As long as a pause on End-of-Record is used, data is not corrupted. The FIFO simply must be reset.

3.11 LOW POWER MODE

The AHA3410C is a data-driven system. When no data transfers are taking place, only the clock and on-chip RAMs including the FIFOs require power. To reduce power consumption to its absolute minimum, the user can stop the clock when it is high. With the system clock stopped and at a high level, the only current required is due to leakage. *Control* and *Status* registers are preserved in this mode. Reinitialization of *Control* registers are not necessary when switching from Low Power to Normal operating mode.

3.12 TEST MODE

In order to facilitate board level testing, the AHA3410C provides the ability to tristate all outputs. When the TEST pin is high, all outputs of the chip are tristated. When test is low, the chip returns to normal operation.

4.0 REGISTER DESCRIPTIONS

The microprocessor configures, controls and monitors IC operation through the use of the registers defined in this section. All write registers are readable with the exception of *Record Length* registers. All registers are reset to '0' on RSTN unless otherwise stated. The bits labeled "res" are reserved and must be set to '0' when writing to registers unless otherwise noted.

A summary of registers is listed below.

Table 5: Internal Registers

ADDRESS	R/W	DESCRIPTION	FUNCTION	DEFAULT AFTER RSTN
00	R/W	System Configuration 0	Big Endian vs. Little Endian, 32-bit vs. 16-bit	Undefined
01	R/W	System Configuration 1	Data Strobe Condition, EOR Request Control, VDO Port Enable, VDI Port Enable	0x00
02	R/W	Input FIFO Thresholds	Input FIFOs Empty Threshold, Full Threshold	Undefined
03	R/W	Output FIFO Thresholds	Output FIFOs Empty Threshold, Full Threshold	Undefined
04	R	Compression Ports Status	FIFO Status, Request Status, EOR Status	Undefined
05	R	Decompression Ports Status	FIFO Status, Request Status, EOR Status	Undefined
06	R/W	Port Control	Reset Individual FIFOs	0x0F
07	R/W	Interrupt Status/Control	EOR, Overflow, Underflow	0x00
09	R/W	Interrupt Mask	Interrupt Mask bits	0xFF
0A	R	Version	Die Version Number	0x21
0C	R/W	Decompression Record Length 0	Bytes Remaining in Transfer, Byte 0	0xFF
0D	R/W	Decompression Record Length 1	" " , Byte 1	0xFF
0E	R/W	Decompression Record Length 2	" " , Byte 2	0xFF
0F	R/W	Decompression Record Length 3	" " , Byte 3	0xFF
10	R/W	Record Length 0	Length of Uncompressed Data in Bytes, Byte 0	Undefined
11	R/W	Record Length 1	" " , Byte 1	Undefined
12	R/W	Record Length 2	" " , Byte 2	Undefined
13	R/W	Record Length 3	" " , Byte 3	Undefined
14	R/W	Compression Control	Pause on Record Boundaries, Enable Compression, Compression Engine Empty Status, Compression Dictionary Reset, Select Pass-Through Mode	0x04
15	R/W	Compression Reserved	For Production Testing Only	0x00
16	R/W	Compression Configuration 0	Line Length Register Lower 8 bits	Undefined
17	R/W	Compression Configuration 1	Line Length Register Upper 3 bits	Undefined

ADDRESS	R/W	DESCRIPTION	FUNCTION	DEFAULT AFTER RSTN
18	R/W	Decompression Control	Pause on Record Boundaries, Enable Decompression Engine, Decompression Engine Empty Status, Dictionary Reset, Enable Pass-Through Mode	0x04
1A	R/W	Decompression Reserved	For Production Testing Only	0x00
1C	R/W	Decompression Configuration 0	Line Length Register Lower 8 bits	Undefined
1D	R/W	Decompression Configuration 1	Line Length Register Upper 3 bits	Undefined

4.1 SYSTEM CONFIGURATION 0, ADDRESS 0x00 - READ/WRITE

Address (hex)	bit7	bit6	bit5	bit4	bit3	bit2	bit1	bit0
00	BIG	WIDE	res			res		

This register is not cleared by reset and must be initialized prior to any data transfer.

X

WIDE - Selects between 32 and 16-bit D buses.

BIG - Select between little and big endian data orders. The least significant bit in a byte is always in position '0'.

BIG	WIDE	DESCRIPTION				
0	0	Little Endian data order 16-bit words D[15:8] D[7:0] <table border="1" style="margin-left: auto; margin-right: auto;"> <tr> <td>Byte 1</td> <td>Byte 0</td> </tr> </table>	Byte 1	Byte 0		
Byte 1	Byte 0					
0	1	Little Endian data order 32-bit words D[31:24] D[23:16] D[15:8] D[7:0] <table border="1" style="margin-left: auto; margin-right: auto;"> <tr> <td>Byte 3</td> <td>Byte 2</td> <td>Byte 1</td> <td>Byte 0</td> </tr> </table>	Byte 3	Byte 2	Byte 1	Byte 0
Byte 3	Byte 2	Byte 1	Byte 0			
1	0	Big Endian data order 16-bit words D[15:8] D[7:0] <table border="1" style="margin-left: auto; margin-right: auto;"> <tr> <td>Byte 0</td> <td>Byte 1</td> </tr> </table>	Byte 0	Byte 1		
Byte 0	Byte 1					
1	1	Big Endian data order 32-bit words D[31:24] D[23:16] D[15:8] D[7:0] <table border="1" style="margin-left: auto; margin-right: auto;"> <tr> <td>Byte 0</td> <td>Byte 1</td> <td>Byte 2</td> <td>Byte 3</td> </tr> </table>	Byte 0	Byte 1	Byte 2	Byte 3
Byte 0	Byte 1	Byte 2	Byte 3			

4.2 SYSTEM CONFIGURATION 1, ADDRESS 0x01 - READ/WRITE

Address (hex)	<i>bit7</i>	<i>bit6</i>	<i>bit5</i>	<i>bit4</i>	<i>bit3</i>	<i>bit2</i>	<i>bit1</i>	<i>bit0</i>
01	<i>res</i>	VDIE	VDOE	ERC	DSC[3:0]			

This register is cleared by reset.

DSC[3:0] - Data Strobe Condition. Control the condition used to strobe data into and out of the data ports on the D bus. Table 4 shows the programming for the strobe condition for DMA data transfer modes.

ERC - EOR Request Control. Determines when COREQN and DOREQN deassert at an End-of-Record. If ERC=0 then the request deasserts asynchronously during the clock when an EOR is strobed out. If ERC=1 then the request deasserts synchronously the clock after an EOR is strobed out. See Figure 19.

VDOE - VDO Port Enable. When this bit is set, the data from the decompression output FIFO goes to the VDO port. When the bit is clear, the decompressed data is read by DMA on the D bus.

VDIE - VDI Port Enable. When this bit is set, the VDI port will handshake data and write it into the compression input FIFO. When the bit is clear, the compression input FIFO is written by DMA from the D bus.

4.3 INPUT FIFO THRESHOLDS, ADDRESS 0x02 - READ/WRITE

Address (hex)	<i>bit7</i>	<i>bit6</i>	<i>bit5</i>	<i>bit4</i>	<i>bit3</i>	<i>bit2</i>	<i>bit1</i>	<i>bit0</i>
02	IFT[3:0]				IET[3:0]			

This register is readable and writable. After reset, its contents are undefined. It must be written before any input or output data movement may be performed.

IET[3:0] - Empty threshold for input FIFOs. If the number of words in the input FIFO (CI or DI) is less than or equal to this number, the request for that channel will be asserted.

IFT[3:0] - Full threshold for input FIFOs. If the number of words in the input FIFO (CI or DI) is greater than or equal to this number, the request for the channel is deasserted.

4.4 OUTPUT FIFO THRESHOLDS, ADDRESS 0x03 - READ/WRITE

Address (hex)	<i>bit7</i>	<i>bit6</i>	<i>bit5</i>	<i>bit4</i>	<i>bit3</i>	<i>bit2</i>	<i>bit1</i>	<i>bit0</i>
03	OFT[3:0]				OET[3:0]			

This register is readable and writable. After reset, its contents are undefined. It must be written before any input or output data movement may be performed.

OET[3:0] - Empty threshold for output FIFOs. If the number of words in the output FIFO (CO or DO) is less than or equal to this number, the request for the channel will be deasserted (except in the case of an End-of-Record).

OFT[3:0] - Full threshold for output FIFOs. If the number of words in the output FIFO (CO or DO) is greater than or equal to this number, the request for that channel will be asserted.

4.5 COMPRESSION PORTS STATUS, ADDRESS 0x04 - READ ONLY

Address (hex)	<i>bit7</i>	<i>bit6</i>	<i>bit5</i>	<i>bit4</i>	<i>bit3</i>	<i>bit2</i>	<i>bit1</i>	<i>bit0</i>
04	COEMP	CIEMP	<i>res</i>	COEOR	COREQ	COET	CIREQ	CIFT

This is a read only register. Writing to this register has no effect. After reset, its contents are undefined.

- CIFT - Compression input FIFO full threshold. This signal is active when the CI FIFO is greater than or equal to the programmed FIFO full threshold. After reset and the *Input FIFO Threshold* register has been written, this bit contains a '0'.
- CIREQ - Compression input request signal state. Reports the current state for the CIREQN pin. Notice that this bit is active high while the pin is active low. Therefore, the value of this bit will always be the inverse of the value of the signal. After reset this bit contains a '0'.
- COET - Compression output FIFO empty threshold. This signal is active when the CO FIFO is less than or equal to the programmed FIFO empty threshold. After reset and the *Output FIFO Threshold* register has been written, this bit contains a '1'.
- COREQ - Compression output request signal state. Reports the current state for the COREQN pin. Notice that this bit is active high while the pin is active low. Therefore, the value of this bit will always be the inverse of the value of the signal. After reset this bit contains a '0'.
- COEOR - Compression output end of record. This signal is active when the output FIFO contains the end-of-record code. After reset this bit contains a '0'.
- CIEMP - Compression input empty. This bit is active when the CI FIFO is empty. After reset this bit contains a '1'.
- COEMP - Compression output empty. This bit is active when the CO FIFO is empty. After reset this bit contains a '1'.

4.6 DECOMPRESSION PORTS STATUS, ADDRESS 0x05 - READ ONLY

Address (hex)	<i>bit7</i>	<i>bit6</i>	<i>bit5</i>	<i>bit4</i>	<i>bit3</i>	<i>bit2</i>	<i>bit1</i>	<i>bit0</i>
05	DOEMP	DIEMP	<i>res</i>	DOEOR	DOREQ	DOET	DIREQ	DIFT

This is a read only register. Writing to this register has no effect. After reset, its contents are undefined.

- DIFT - Decompression input FIFO full threshold. This signal is active when the DI FIFO is at or above the programmed FIFO full threshold. After reset and the *Input FIFO Threshold* register has been written, this bit contains a '0'.
- DIREQ - Decompression input request signal state. Reports the current state for the DIREQN pin. Notice that this bit is active high while the pin is active low. Therefore, the value of this bit will always be the inverse of the value of the signal. After reset this bit contains a '0'.
- DOET - Decompression output FIFO empty threshold. This signal is active when the DO FIFO is at or below the programmed FIFO empty threshold. After reset and the *Output FIFO Threshold* register has been written, this bit contains a '1'.
- DOREQ - Decompression output request signal state. Reports the current state for the DOREQN pin. Notice that this bit is active high while the pin is active low. Therefore, the value of this bit will always be the inverse of the value of the signal. After reset this bit contains a '0'.
- DOEOR - Decompression output end of record. This signal is active when the output FIFO contains the End-of-Record code. After reset this bit contains a '0'.
- DIEMP - Decompression input empty. This bit is active when the DI FIFO is empty. After reset this bit contains a '1'.
- DOEMP - Decompression output empty. This bit is active when the DO FIFO is empty. After reset this bit contains a '1'.

4.7 PORT CONTROL, ADDRESS 0x06 - READ/WRITE

Address (hex)	<i>bit7</i>	<i>bit6</i>	<i>bit5</i>	<i>bit4</i>	<i>bit3</i>	<i>bit2</i>	<i>bit1</i>	<i>bit0</i>
06	<i>res</i>				DORST	DIRST	CORST	CIRST

This register is initialized to '0F' after reset.

- CIRST - Compression input reset. Setting this bit to a '1' resets the CI FIFO and clears state machines on the compression input port. The reset condition will remain active until the microprocessor writes a '0' to this bit.
- CORST - Compression output reset. Setting this bit to a '1' resets the CO FIFO and clears state machines on the compression output port. The reset condition will remain active until the microprocessor writes a '0' to this bit.
- DIRST - Decompression input reset. Setting this bit to a '1' resets the DI FIFO and clears the state machines in the decompression input port. The reset condition will remain active until the microprocessor writes a '0' to this bit.
- DORST - Decompression output reset. Setting this bit to a '1' resets the DO FIFO and clears the state machines in the decompression output port. The reset condition will remain active until the microprocessor writes a '0' to this bit.

4.8 INTERRUPT STATUS/CONTROL, ADDRESS 0x07 - READ/WRITE

Address (hex)	<i>bit7</i>	<i>bit6</i>	<i>bit5</i>	<i>bit4</i>	<i>bit3</i>	<i>bit2</i>	<i>bit1</i>	<i>bit0</i>
07	DOUF	COUF	DIOF	CIOF	<i>res</i>	DERR	DEOR	CEOR

This register is initialized to '00' after reset.

- CEOR - Compression End-of-Record interrupt. This bit is set when an End-of-Record codeword is strobed out of the compression output port. To clear this interrupt the microprocessor must write a '1' to this bit.
- DEOR - Decompression End-of-Record interrupt. This bit is set when the last byte of a record is strobed out of the decompression DMA or video output port. To clear this interrupt the microprocessor must write a '1' to this bit.
- DERR - Decompression Error. This bit is set if an EOR leaves the decompressor before DRLEN has counted down to zero or if DRLEN counts to zero and the last byte is not an EOR. DERR is only active in decompression mode (DPASS=0). To clear this interrupt, the microprocessor must write a '1' to this bit.
- CIOF - Compression Input FIFO Overflow. This interrupt is generated when a write to the CI FIFO is performed when it is full. All data written when the FIFO is full is lost. The only means of recovery from this error is to reset the FIFO with the CIRST bit. Resetting the FIFO causes this interrupt to clear. While the interrupt is set CIREQN is inactive.
- DIOF - Decompression Input FIFO Overflow. This interrupt is generated when a write to the DI FIFO is performed when it is full. All data written when the FIFO is full is lost. The only means of recovery from this error is to reset the FIFO with the DIRST bit. Resetting the FIFO causes this interrupt to clear. While the interrupt is set DIREQN is inactive.

- COUF - Compression Output FIFO underflow. This interrupt is generated when a read from the CO FIFO is performed when it is empty. Once this interrupt is set, the CO FIFO must be reset with the CORST bit. To clear this interrupt the microprocessor must write a '1' to this bit. While the interrupt is set, COREQN is inactive.
- DOUF - Decompression Output FIFO underflow. This interrupt is generated when a read from the DO FIFO is performed when it is empty. Once this interrupt is set, the DO FIFO must be reset with the DORST bit. To clear this interrupt the microprocessor must write a '1' to this bit. While the interrupt is set, DOREQN is inactive.

4.9 INTERRUPT MASK, ADDRESS 0x09 - READ/WRITE

Address (hex)	<i>bit7</i>	<i>bit6</i>	<i>bit5</i>	<i>bit4</i>	<i>bit3</i>	<i>bit2</i>	<i>bit1</i>	<i>bit0</i>
09	DOUFM	COUFM	DIOFM	CIOFM	<i>res</i>	DERRM	DEORM	CEORM

This register is initialized to 'FF' after reset.

- CEORM - Compression End-of-Record Interrupt Mask. When set to a '1', prevents Compression End-of-Record from causing INTRN to go active.
- DEORM - Decompression End-of-Record Interrupt Mask. When set to a '1', prevents Decompression End-of-Record from causing INTRN to go active.
- DERRM - Decompression Error Mask. When set to a '1', prevents a decompression error (DERR) from causing INTRN to go active.
- CIOFM - Compression Input FIFO Overflow Mask. When set to a '1', prevents a compression input FIFO overflow (CIOF) from causing INTRN to go active.
- DIOFM - Decompression Input FIFO Overflow Mask. When set to a '1', prevents a decompression input FIFO overflow (DIOF) from causing INTRN to go active.
- COUFM - Compression Output FIFO Underflow Mask. When set to a '1', prevents a compression output FIFO underflow (COUF) from causing INTRN to go active.
- DOUFM - Decompression Output FIFO Underflow Mask. When set to a '1', prevents a decompression output FIFO underflow (DOUF) from causing INTRN to go active.

4.10 VERSION, ADDRESS 0x0A - READ ONLY

Address (hex)	<i>bit7</i>	<i>bit6</i>	<i>bit5</i>	<i>bit4</i>	<i>bit3</i>	<i>bit2</i>	<i>bit1</i>	<i>bit0</i>
0A	VERSION[7:0]							

This is a read only register. Writing to this register has no effect on IC operation.

VERSION[7:0] - Contains version number of the die. Initial version is 0x21.

4.11 DECOMPRESSION RECORD LENGTH, ADDRESS 0x0C, 0x0D, 0x0E, 0x0F - READ/WRITE

Address (hex)	<i>bit7</i>	<i>bit6</i>	<i>bit5</i>	<i>bit4</i>	<i>bit3</i>	<i>bit2</i>	<i>bit1</i>	<i>bit0</i>
0C	DRLEN[7:0]							
0D	DRLEN[15:8]							
0E	DRLEN[23:16]							
0F	DRLEN[31:24]							

These registers are initialized to 'FF' after reset.

DRLEN[31:0]-Decompression Record Length. Contains the number of bytes in a decompressed record.

These registers provide different functions depending on whether the decompressor is in pass-through or decompression mode. In decompress mode, the data itself contains EOR information and DRLEN is only used for error checking. DRLEN is decremented each time a byte leaves the decompressor.

In decompression mode, a DERR interrupt is issued if an EOR is not read out of the decompressor when the counter expires or if an EOR occurs before the counter expires (i.e., when the record lengths do not match). If the DERR interrupt is masked, use of the DRLEN register is optional in decompression mode.

In pass-through mode, DRLEN determines the size of records read out of the decompressor. The counter is decremented for each byte read into the decompressor.

In either mode, the counter reloads when it reaches zero or when DRLEN[31:24] is written. Reading DRLEN returns the number of bytes left in the count.

4.12 RECORD LENGTH, ADDRESS 0x10, 0x11, 0x12, 0x13 - READ/WRITE

Address (hex)	<i>bit7</i>	<i>bit6</i>	<i>bit5</i>	<i>bit4</i>	<i>bit3</i>	<i>bit2</i>	<i>bit1</i>	<i>bit0</i>
10	RLEN[7:0]							
11	RLEN[15:8]							
12	RLEN[23:16]							
13	RLEN[31:24]							

These registers are undefined after reset.

RLEN[31:0]- Record Length. Length of an uncompressed record in bytes. Writing these addresses sets a register containing the length of a record. Reading these addresses returns a counter indicating the number of bytes remaining in the current record. The counter is decremented each time a byte leaves the CI FIFO. The counter automatically reloads from the register at the end of a record. The counter is also reloaded when RLEN[31:24] is written. The record length register is also valid during pass-through operation.

The minimum value for RLEN is 4.

4.13 COMPRESSION CONTROL, ADDRESS 0x14 - READ/WRITE

Address (hex)	<i>bit7</i>	<i>bit6</i>	<i>bit5</i>	<i>bit4</i>	<i>bit3</i>	<i>bit2</i>	<i>bit1</i>	<i>bit0</i>
14	<i>res</i>			CPASS	CDR	CEMP	COMP	CPOR

This register is initialized to '04' after reset.

- CPOR - Compression Pause on record boundaries. When this bit is set to '1', the compressor stops taking data from the input FIFO once a record boundary is found. A record boundary is indicated by the RLEN register decrementing to '0'. Upon finding the record boundary, COMP is cleared. This bit may only be changed when COMP is set to '0'. After system reset, this bit is cleared.
- COMP - Compression. Setting this bit to a '1' enables the data compression engine (or pass-through mode if CPASS is set) to take data from the compression input FIFO. If this bit is cleared, compression stops. The bit is automatically cleared at the end of a record if CPOR is set. The compression can be restarted without loss of data by setting COMP. After reset, this bit is cleared.
- CEMP - Compression engine empty. This bit is set to a '1' when no data is present inside the compressor. Writing to this bit has no effect. After system reset, this bit is set.
- CDR - Compression Dictionary Reset. Setting this bit immediately resets the compressor including the compression dictionary. The reset condition will remain active until the microprocessor writes a '0' to this bit.
- CPASS - Compression pass-through mode. While this bit is set, data is passed directly through the compression engine without any effect on either the dictionary or the data itself. This bit may only be changed when compression is disabled (COMP=0) and the compression engine is empty of data (CEMP=0). The pass-through operation is started by setting COMP. To stop the pass-through operation, COMP should be cleared (to pause operation) and then CPASS may be cleared.
- bit[5] - Reserved. Set to '0'.
- bit[7:6] - Reserved. Set to '0'.

4.14 COMPRESSION RESERVED, ADDRESS 0x15 - READ/WRITE

Address (hex)	<i>bit7</i>	<i>bit6</i>	<i>bit5</i>	<i>bit4</i>	<i>bit3</i>	<i>bit2</i>	<i>bit1</i>	<i>bit0</i>
15	<i>res</i>							

This register is used for production testing. Must be written with '0' if at all. Resets to '0'.

4.15 COMPRESSION CONFIGURATION, ADDRESS 0x16, 0x17 - READ/WRITE

Address (hex)	<i>bit7</i>	<i>bit6</i>	<i>bit5</i>	<i>bit4</i>	<i>bit3</i>	<i>bit2</i>	<i>bit1</i>	<i>bit0</i>
16	LINE[7:0]							
17	<i>res</i>					LINE[10:8]		

This register contains information necessary for the compression operation. It must be set prior to any compression operation. It should only be changed when COMP is cleared and CEMP is set. After changing compression configuration, the compressor should be reset using CDR. These registers are undefined after reset.

LINE[10:0]-Line length. The number of bytes in the scan line is programmed here. Minimum value is 16.

4.16 DECOMPRESSION CONTROL, ADDRESS 0x18 - READ/WRITE

Address (hex)	<i>bit7</i>	<i>bit6</i>	<i>bit5</i>	<i>bit4</i>	<i>bit3</i>	<i>bit2</i>	<i>bit1</i>	<i>bit0</i>
18	<i>res</i>			DPASS	DDR	DEMP	DCOMP	DPOR

This register is initialized to '04' after reset.

- DPOR - Decompression Pause on record boundaries. When this bit is set to '1', the decompressor stops taking data from the input FIFO once a record boundary is found. Upon finding the record boundary, DCOMP is cleared. This bit may only be changed when DCOMP is set to '0'. After system reset or DDR, this bit is cleared.
- DCOMP - Decompression. Setting this bit to a '1' enables the decompression engine (or pass-through mode if DPASS is set) to take data from the decompression input FIFO. If this bit is cleared, decompression stops. The bit is automatically cleared at the end of a record if DPOR is set. Decompression can be restarted without loss of data by setting DCOMP. After system reset or DDR, this bit is cleared.
- DEMP - Decompression engine empty. This bit is set when the decompression engine is cleared of data. Writing to this bit has no effect. After system reset, this bit is set.
- DDR - Decompression Dictionary Reset. Setting this bit immediately resets the decompressor including the decompression dictionary. The reset condition will remain active until the microprocessor writes a '0' to this bit.
- DPASS - Decompression pass-through mode. While this bit is set, data is passed directly through the decompression engine without any effect on the data. This bit may only be changed when decompression is disabled (DCOMP=0) and the decompression engine is empty of data (DEMP=1). The pass-through operation is started by setting DCOMP. To stop the pass-through operation, DCOMP should be cleared (to pause operation) and then DPASS may be cleared.

4.17 DECOMPRESSION RESERVED, ADDRESS 0x1A - READ/WRITE

Address (hex)	<i>bit7</i>	<i>bit6</i>	<i>bit5</i>	<i>bit4</i>	<i>bit3</i>	<i>bit2</i>	<i>bit1</i>	<i>bit0</i>
1A	<i>res</i>							

This register is used for production testing only. Must be written with '0' if at all. Initialized to '00' after reset.

4.18 DECOMPRESSION CONFIGURATION, ADDRESS 0x1C, 0x1D - READ/WRITE

Address (hex)	<i>bit7</i>	<i>bit6</i>	<i>bit5</i>	<i>bit4</i>	<i>bit3</i>	<i>bit2</i>	<i>bit1</i>	<i>bit0</i>
1C	LINE[7:0]							
1D	<i>res</i>					LINE[10:8]		

This register contains information necessary for the decompression operation. It must be set prior to any decompression operation. It should only be changed between records when DCOMP is cleared and DEMP is set. These registers are undefined after reset.

LINE[10:0]-Line length. The number of bytes in the scan line is programmed here. Minimum value is 16. For scan line lengths larger than the maximum allowed, set to 16.

5.0 SIGNAL DESCRIPTIONS

This section contains descriptions for all the pins. Each signal has a type code associated with it. The type codes are described in the following table.

<i>TYPE CODE</i>	<i>DESCRIPTION</i>
I	Input only pin
O	Output only pin
I/O	Input/Output pin
S	Synchronous signal
A	Asynchronous signal

5.1 MICROPROCESSOR INTERFACE

<i>MICROPROCESSOR INTERFACE</i>		
<i>SIGNAL</i>	<i>TYPE</i>	<i>DESCRIPTION</i>
PD[7:0]	I/O S	Processor Data. Data for all microprocessor reads and writes of registers within StarLite™ are performed on this bus. This bus may be tied to the Data bus, D[31:0], provided microprocessor accesses do not occur at the same time as DMA accesses.
PA[4:0]	I S	Processor Address Bus. Used to address internal registers within StarLite™.
CSN	I S	Chip Select. Selects StarLite™ as the source or destination of the current microprocessor bus cycle. CSN needs only be active for one clock cycle to start a microprocessor access.
DIR	I S	Direction. This signal indicates whether the access to the register specified by the PA bus is a read or a write. The polarity of this signal is programmed with the PROCMODE0 pin.
RDYN	O A,S	Ready. Indicates valid data is on the data bus during read operation and completion of write operation. Its operation depends on PROCMODE[1:0] settings.
INTRN	O S	Interrupt. The compression and decompression processes generate interrupts that are reported with this signal. INTRN is low whenever any non-masked bits are set in the <i>Interrupt Status/Control</i> register.
PROCMODE[1:0]	I S	Microprocessor Port Configuration Mode. Selects the polarity of the DIR pin and operation of the CSN pin. 00 Active high write, fixed cycle 01 Active low write, fixed cycle 10 Active high write, variable cycle 11 Active low write, variable cycle (See Figure 2 through Figure 5 for details.)

5.2 DATA INTERFACE

DATA INTERFACE		
SIGNAL	TYPE	DESCRIPTION
D[31:0]	I/O S	Data for all channels is transmitted on this bus. The ACKN or FA[1:0] is used to distinguish between the four channels. Data being written to StarLite™ is latched on the rising edge of CLOCK when the strobe condition is met. Data setup and hold times are relative to CLOCK. If the bus is configured to 16-bit transfers (WIDE=0), data is carried on D[15:0]. In this case, D[31:16] should be terminated with pullup resistors.
DRIVEN	I A	Drive Enable. Active low output driver enable. This input must be low in order to drive data onto D[31:0] in accordance with the current strobe condition.
SD	I S	Strobe Delay. Allows insertion of wait states for DMA access to the FIFOs. The strobe condition, as programmed in the DSC field of <i>System Configuration 1</i> , enables this signal and selects its polarity.
CIREQN	O S	Compression Input Data Request, active low. This signal, when active, indicates the ability of the CI FIFO to accept data.
CIACKN	I S	Compression Input Data Acknowledge for DMA mode (DSC[3]=0). Active low compression data input. This signal, when active, indicates the data on D is for the compression input FIFO. Data on D is latched on the rising edge of CLOCK when the strobe condition is met.
COREQN	O A,S	Compression Output Data Request, active low. When this signal is active, it indicates the ability of the CO FIFO to transmit data.
COACKN	I S	Compression Output Data Acknowledge for DMA mode (DSC[3]=0). The definition of COACKN varies with the data strobe condition in <i>System Configuration 1</i> .
COEORN	O S	Compression Output End-of-Record, active low. COEORN is active when the word currently on the output of the CO FIFO contains an End-of-Record.
DIREQN	O S	Decompression Input Data Request, active low. When this signal is active, it indicates the ability of the DI port to accept data.
DIACKN	I S	Decompression Input Data Acknowledge for DMA mode (DSC[3]=0). Active low decompression data input. When this signal is active, it indicates the data on D is for the decompression input port. Data on D is latched on the rising edge of CLOCK when the strobe condition is met.
DOREQN	O A, S	Decompression Output Data Request, active low. When this signal is active, it indicates the ability of the DO port to transmit data.
DOACKN	I S	Decompression Output Data Acknowledge for DMA mode (DSC[3]=0). The definition of DOACKN varies with the data strobe condition in <i>System Configuration 1</i> .

5.3 VIDEO INTERFACE

<i>VIDEO INTERFACE</i>		
<i>SIGNAL</i>	<i>TYPE</i>	<i>DESCRIPTION</i>
VIREQN	O S	Video Input Request. Active low output indicating that the VDI port is ready to accept another byte on VID[7:0].
VIACKN	I S	Video Input Acknowledge. Active low input indicating that VID[7:0] is being driven with a valid byte.
VID[7:0]	I S	Video Input Data. The value on this input bus is written into StarLite™ when both VIREQN and VIACKN are active.
VOREQN	O S	Video Output Request. Active low output indicating that the byte on VOD[7:0] is valid.
VOACKN	I S	Video Output Acknowledge. Active low input indicating that the external system is ready to read VOD[7:0].
VOD[7:0]	O S	Video Output Data. The value on this output bus is read when both VOREQN and VOACKN are low.
VOEORN	O S	Video Output End-of-Record. Active low output indicating that the byte on VOD[7:0] contains the last byte in a record.

5.4 SYSTEM CONTROL

<i>SYSTEM CONTROL</i>		
<i>SIGNAL</i>	<i>TYPE</i>	<i>DESCRIPTION</i>
CLOCK	I	System Clock. This signal is connected to the clock of the microprocessor. For AMD microprocessors, this pin is either called MEMCLK (29030 and 29200) or SYSCLK (29000). The Intel i960Cx calls this pin PCLK.
RSTN	I A	Power on Reset. Active low reset signal. StarLite™ must be reset before any DMA or microprocessor activity is attempted. RSTN should be a minimum of 10 CLOCK periods.
TEST	I A	Board Test mode. When TEST is high, all outputs are tristated. When TEST is low, the chip performs normally.

6.0 PINOUT

PIN DESIGNATION

<i>SIGNAL</i>	<i>PIN</i>	<i>SIGNAL</i>	<i>PIN</i>	<i>SIGNAL</i>	<i>PIN</i>	<i>SIGNAL</i>	<i>PIN</i>
VID[4]	1	D[7]	31	D[25]	61	VDD	91
VID[3]	2	D[8]	32	D[26]	62	VSS	92
VID[2]	3	D[9]	33	D[27]	63	PA[4]	93
VID[1]	4	D[10]	34	D[28]	64	VDD	94
VID[0]	5	D[11]	35	D[29]	65	PROCMODE[1]	95
INTRN	6	VSS	36	D[30]	66	PROCMODE[0]	96
VSS	7	VDD	37	VDD	67	CSN	97
VDD	8	D[12]	38	VSS	68	VDD	98
DRIVEN	9	D[13]	39	D[31]	69	VSS	99
SD	10	D[14]	40	VOREQN	70	DIR	100
DOACKN	11	VSS	41	VOEORN	71	RSTN	101
COACKN	12	VSS	42	VOD[0]	72	PD[7]	102
DIACKN	13	VDD	43	VOD[1]	73	PD[6]	103
CIACKN	14	CLK	44	VOD[2]	74	PD[5]	104
VSS	15	VSS	45	VDD	75	VDD	105
VDD	16	VDD	46	VSS	76	VSS	106
DOREQN	17	VSS	47	VOD[3]	77	PD[4]	107
COREQN	18	VDD	48	VOD[4]	78	PD[3]	108
DIREQN	19	D[15]	49	VOD[5]	79	PD[2]	109
CIREQN	20	D[16]	50	VOD[6]	80	PD[1]	110
VIREQN	21	D[17]	51	VOD[7]	81	PD[0]	111
D[0]	22	D[18]	52	COEORN	82	VDD	112
VSS	23	D[19]	53	VDD	83	VSS	113
VDD	24	D[20]	54	VSS	84	RDYN	114
D[1]	25	D[21]	55	VOACKN	85	VIACKN	115
D[2]	26	D[22]	56	TEST	86	VID[7]	116
D[3]	27	D[23]	57	PA[0]	87	VID[6]	117
D[4]	28	D[24]	58	PA[1]	88	VID[5]	118
D[5]	29	VSS	59	PA[2]	89	VDD	119
D[6]	30	VDD	60	PA[3]	90	VSS	120

Figure 16: Pinout

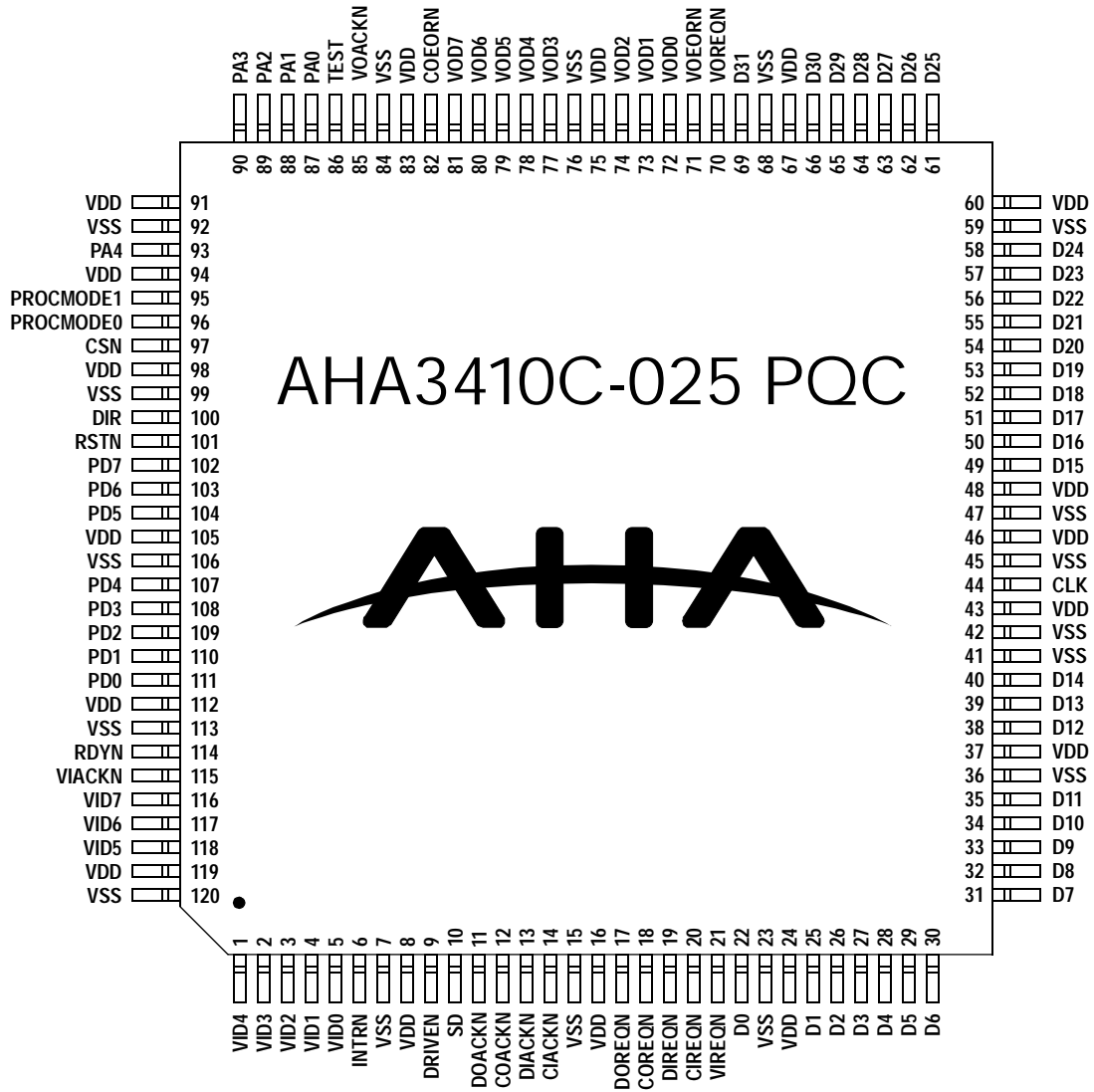

7.0 DC ELECTRICAL SPECIFICATIONS

7.1 OPERATING CONDITIONS

OPERATING CONDITIONS					
SYMBOL	PARAMETER	MIN	MAX	UNITS	NOTES
Vdd	Supply voltage	4.75	5.25	V	
Idd	Supply current (active)		300	mA	1
Idd	Supply current (standby)		26	mA	2
Idd	Supply current (low power)		1	mA	3
Ta	Ambient temperature	0	70	°C	
Vil	Input low voltage	Vss-0.5	0.8	V	
Vih	Input high voltage	2.0	Vdd+0.5	V	
Ii	Input leakage current	-10	10	μA	
Vol	Output low voltage (Iol=-4mA)		0.4	V	5
Voh	Output high voltage (Ioh=4mA)	2.4		V	5
Voh	Output high voltage (Ioh=100μA)	Vdd-0.8		V	5
Iol	Output low current		4	mA	
Ioh	Output high current		-4	mA	
Ioz	Output leakage current	-10	10	μA	
Ioz	High impedance leakage current	-10	10	μA	
Cin	Input capacitance		5	pF	
Cout	Output capacitance		7	pF	
Cio	Input/Output capacitance		7	pF	
Comax	Maximum capacitance load for all signals (including self loading)		50	pF	4

Notes:

- 1) Dynamic current (Iout=0mA) - see Figure 17
- 2) Dynamic current; no data transfers
- 3) Static current (clock high)
- 4) Timings referenced to this load
- 5) Output AC timings referenced to Vol for high to low transitions and Voh for low to high transitions.

7.2 ABSOLUTE MAXIMUM STRESS RATINGS

ABSOLUTE MAXIMUM STRESS RATINGS					
SYMBOL	PARAMETER	MIN	MAX	UNITS	NOTES
Tstg	Storage temperature	-50	150	°C	
Vdd	Supply voltage	-0.5	7	V	
Vin	Input voltage	Vss-0.5	Vdd+0.5	V	
Ilp	Latch-up current		100	mA	
ESD	Electro-static discharge	-2,000	+2,000	V	1

Notes:

- 1) Human body model

Figure 17: Power vs. Data Rate at 25 MHz Operation

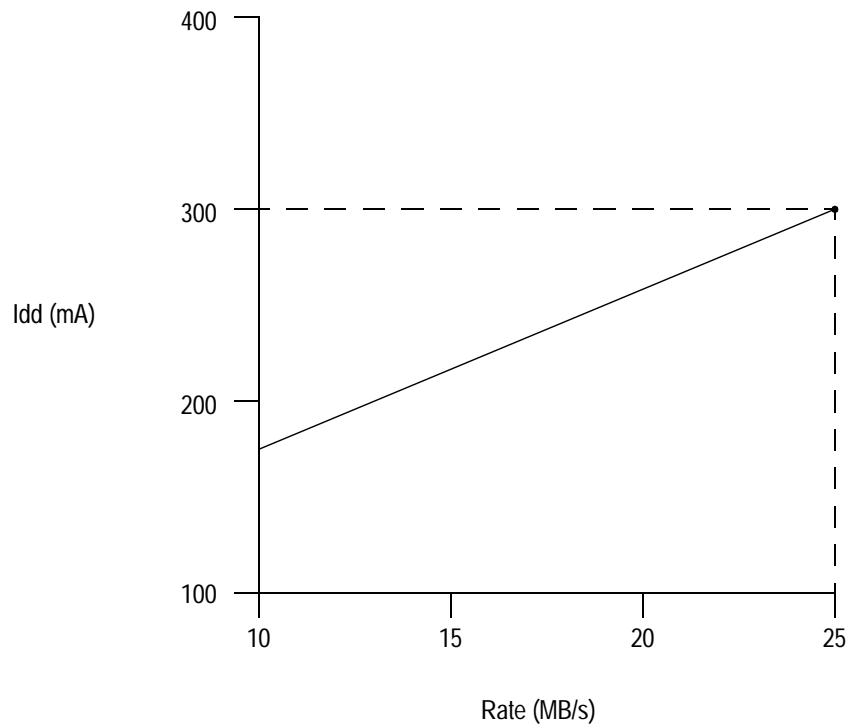

Notes:

- 1) *Power scales linearly with frequency at a given data rate.*
- 2) *$I_{out}=0$ mA into 50 pF output loads.*

8.0 AC ELECTRICAL SPECIFICATIONS

Figure 18: Data Interface Timing

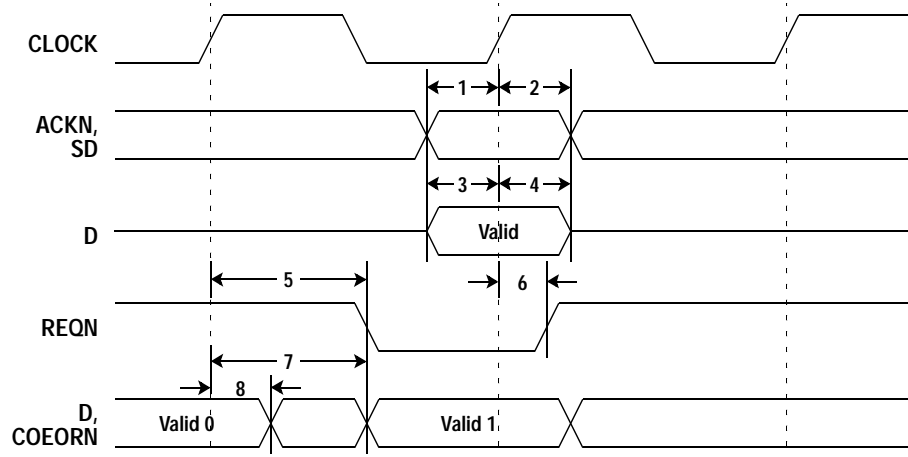

Table 6: Data Port Timing Requirements

NUMBER	PARAMETER	MIN	MAX	UNITS	NOTES
1	CIACKN, DIACKN, COACKN, DOACKN and SD setup time	8		ns	
2	CIACKN, DIACKN, COACKN, DOACKN and SD hold time	2		ns	2
3	D-bus input setup time	8		ns	
4	D-bus input hold time	2		ns	
5	REQN delay (non-EOR case)		18	ns	1
6	REQN hold (non-EOR case)	2		ns	
7	D-bus, COEORN output delay		23	ns	
8	D-bus, COEORN output hold	2		ns	

Notes:

- 1) Production test condition is 50 pF. Delay is decreased 2 ns with 25 pF load guaranteed by design or characterization.
- 2) Input timings are referenced to 1.4 volts.

Figure 19: Request Deasserts at EOR, Strobe Condition of DSC=0-3, 6-15; ERC=0

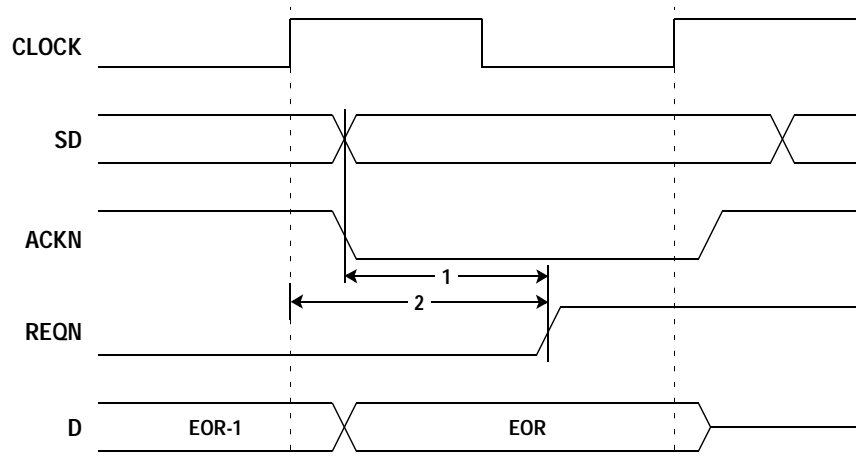

Figure 20: Request Deasserts at EOR, Strobe Condition of DSC=0-3, 6-15; ERC=1

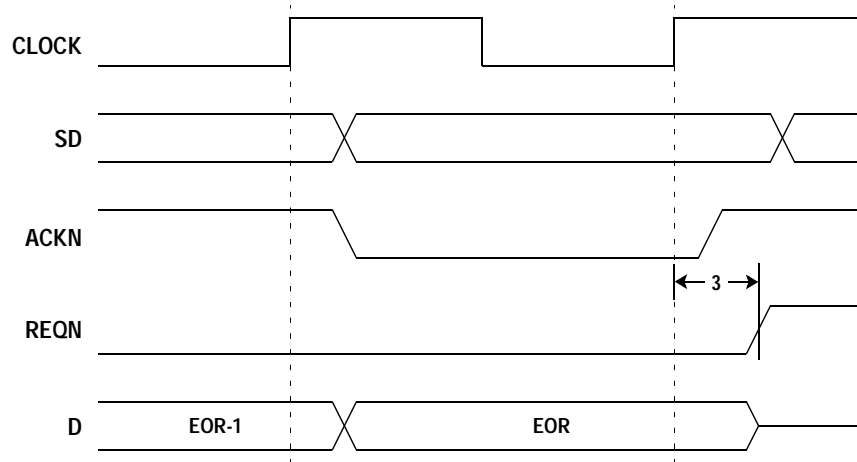

Figure 21: Request Deasserts at EOR, Strobe Condition of DSC=4 or 5; ERC=0

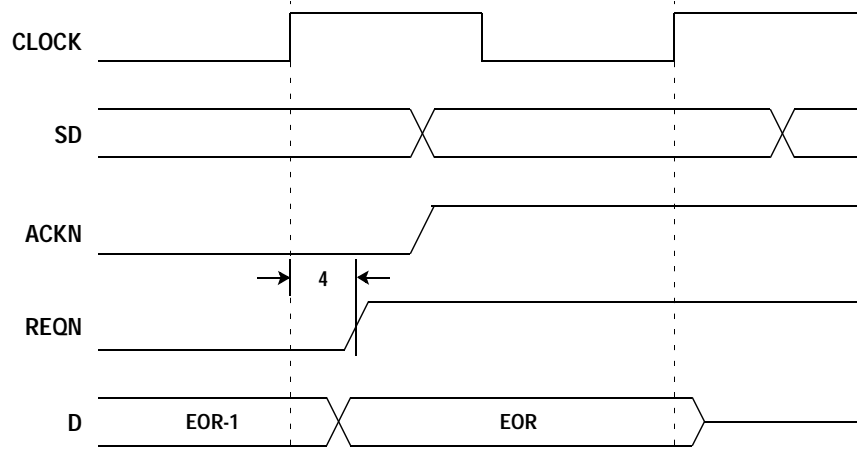

Figure 22: Request Deasserts at EOR, Strobe Condition of DSC=4 or 5; ERC=1

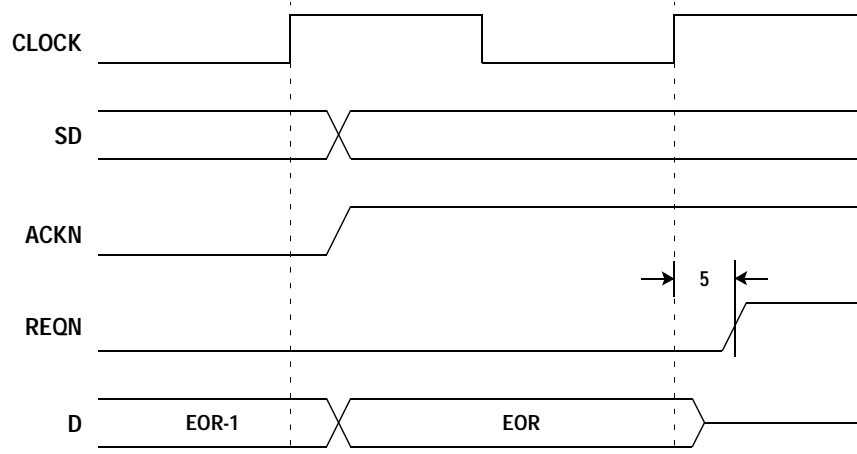

Table 7: Request vs. EOR Timing

NUMBER	PARAMETER	MIN	MAX	UNITS	NOTES
1	ACKN, SD to REQN DSC=0-15; ERC=0		20	ns	1
2	CLOCK to REQN DSC=0-3, 6-9; ERC=0		21	ns	1
	CLOCK to REQN DSC=10-15; ERC=0		23	ns	1
3	CLOCK to REQN DSC=0-3, 6-15; ERC=1		18	ns	1
4	CLOCK to REQN DSC=4, 5; ERC=0		21	ns	1
5	CLOCK to REQN DSC=4, 5; ERC=1		18	ns	1

Notes:

- 1) Production test condition is 50 pF. Delay is decreased 2 ns with 25 pF load guaranteed by design or characterization.

Figure 23: Output Enable Timing

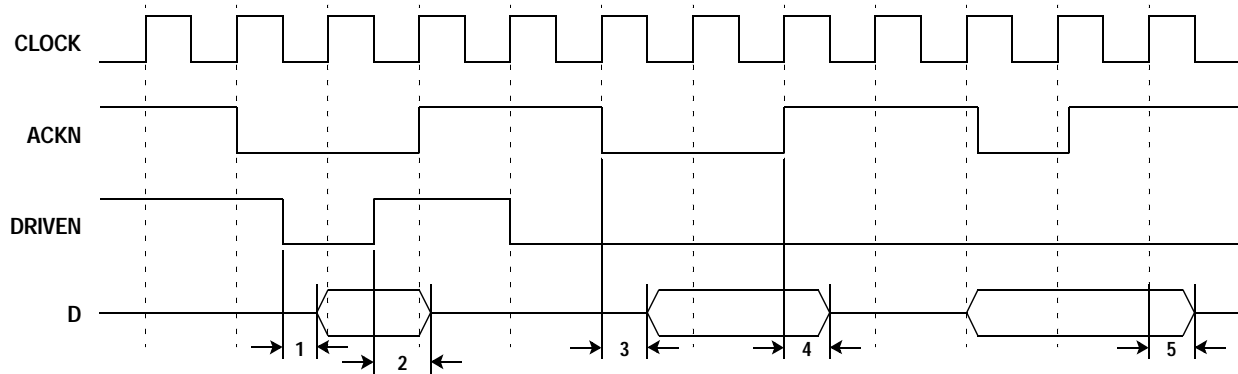

Table 8: Output Enable Timing Requirements

NUMBER	PARAMETER	MIN	MAX	UNITS	NOTES
1	DRIVEN to D valid		15	ns	
2	DRIVEN to D tristate		10	ns	
3	Signal to D valid		15	ns	
4	Signal to D tristate		10	ns	
5	CLOCK to D tristate (DSC=100, 101)		15	ns	

Figure 24: Video Input Port Timing

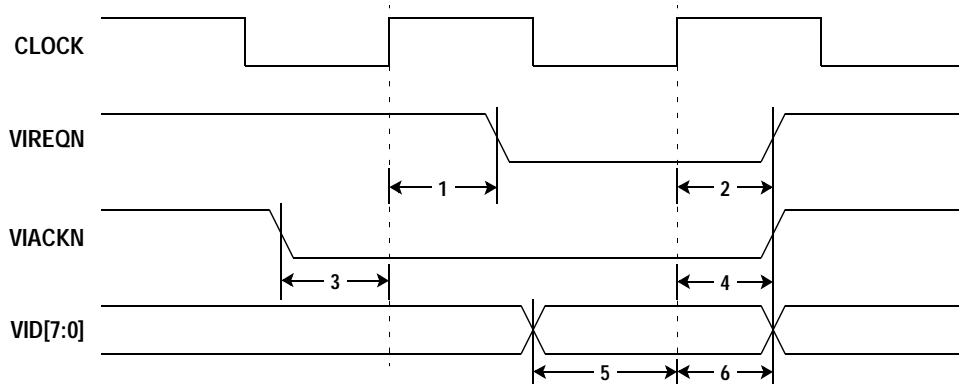

Table 9: Video Input Port Timing Requirements

NUMBER	PARAMETER	MIN	MAX	UNITS	NOTES
1	VIREQN delay		16	ns	
2	VIREQN hold	2		ns	
3	VIACKN setup	8		ns	
4	VIACKN hold	2		ns	
5	VID setup	8		ns	
6	VID hold	2		ns	

Figure 25: Video Output Port Timing

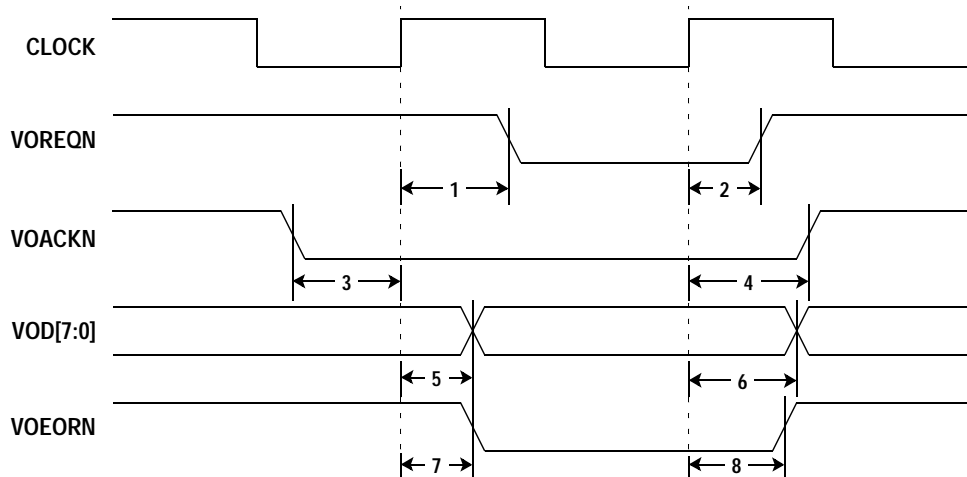

Table 10: Video Output Port Timing Requirements

NUMBER	PARAMETER	MIN	MAX	UNITS	NOTES
1	VOREQN delay		19	ns	1
2	VOREQN hold	4		ns	
3	VOACKN setup	8		ns	
4	VOACKN hold	3		ns	
5	VOD delay		21	ns	1
6	VOD hold	3.7		ns	
7	VOEORN hold	3.7		ns	
8	VOEORN delay		21	ns	1

Notes:

1) Production test condition is 50 pF. Delay is decreased 2 ns with 25 pF load guaranteed by design or characterization.

Figure 26: Microprocessor Interface Timing (PROCMODE[1]=0)

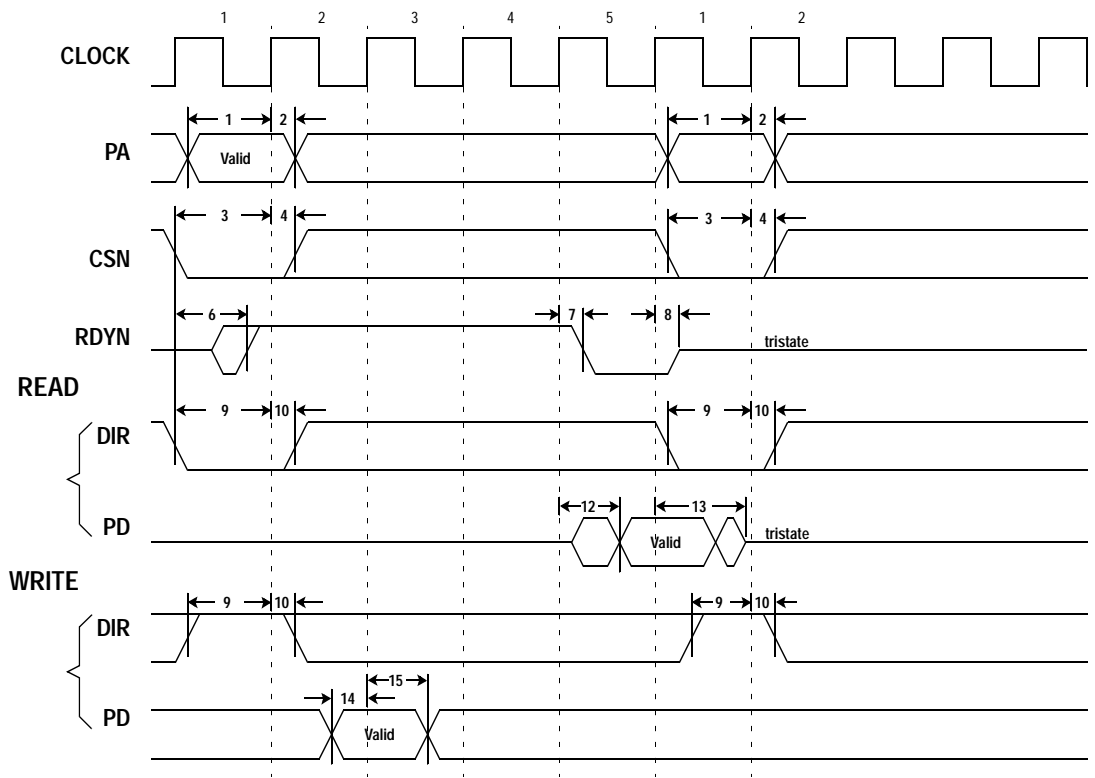

Figure 27: Microprocessor Interface Timing (PROCMODE[1]=1)

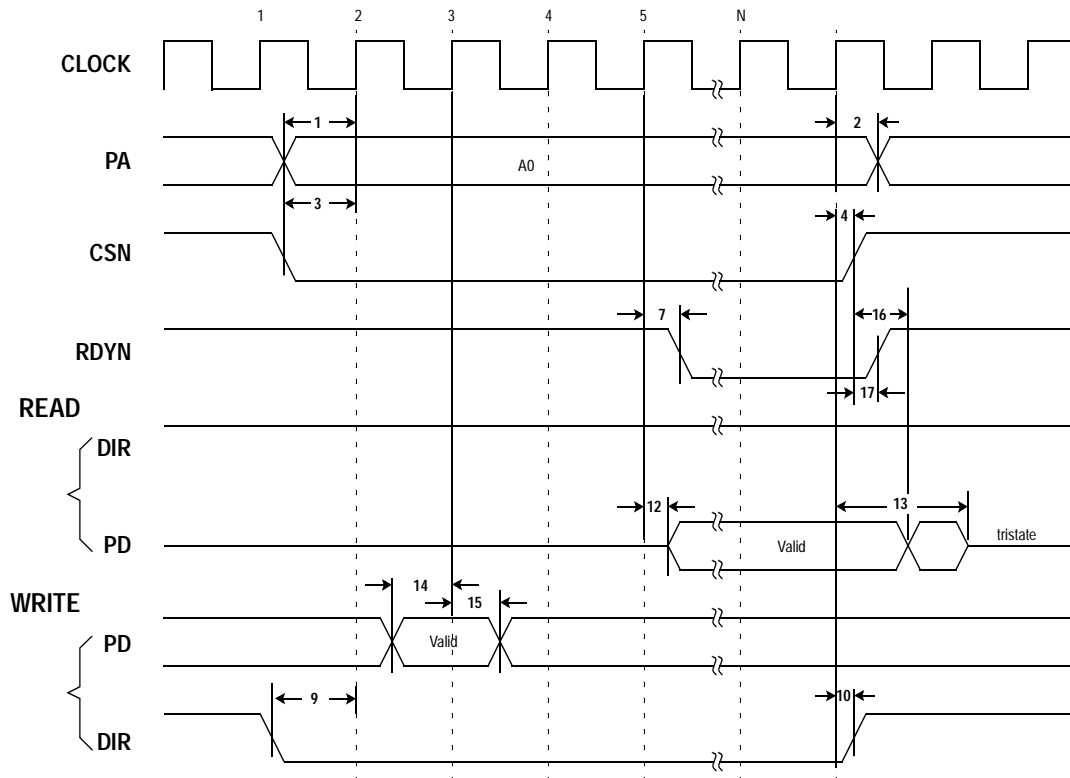

Table 11: Microprocessor Interface Timing Requirements

NUMBER	PARAMETER	MIN	MAX	UNITS	NOTES
1	PA setup time	10		ns	
2	PA hold time	3		ns	
3	CSN setup time	10		ns	
4	CSN hold time	3		ns	
6	CSN to valid RDYN		15	ns	
7	RDYN valid delay		20	ns	
8	RDYN drive disable		10	ns	
9	DIR setup time	10		ns	
10	DIR hold time	3		ns	
12	PD valid delay		20	ns	
13	PD drive disable		12	ns	
14	PD setup time	10		ns	
15	PD hold time	3		ns	
16	CSN high to PD tristate		10	ns	
17	CSN high to RDYN high		15	ns	

Figure 28: Interrupt Timing

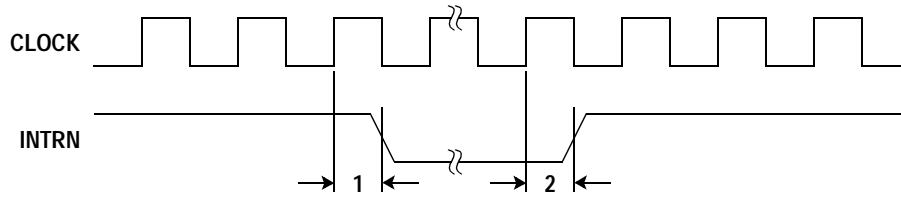

Table 12: Interrupt Timing Requirements

NUMBER	PARAMETER	MIN	MAX	UNITS	NOTES
1	INTRN delay time		15	ns	
2	INTRN hold time	3		ns	

Figure 29: Clock Timing

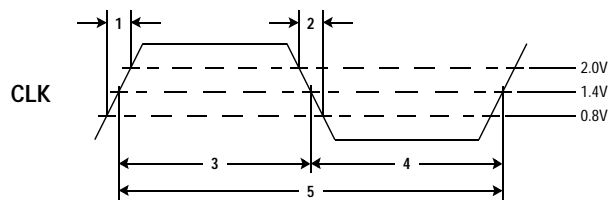

Table 13: Clock Timing Requirements

NUMBER	PARAMETER	MIN	MAX	UNITS	NOTES
1	CLOCK rise time		5	ns	
2	CLOCK fall time		5	ns	
3	CLOCK high time	15		ns	
4	CLOCK low time	16		ns	
5	CLOCK period	40		ns	

Figure 30: Power On Reset Timing

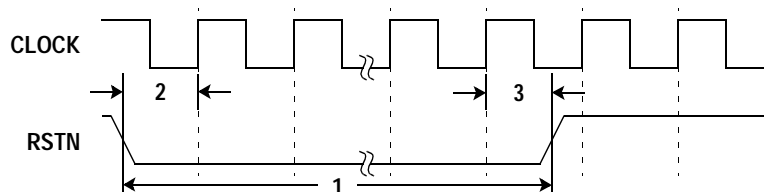

Table 14: Power On Reset Timing Requirements

NUMBER	PARAMETER	MIN	MAX	UNITS	NOTES
1	RSTN low pulsewidth	10		clocks	
2	RSTN setup to CLOCK rise	15		ns	1
3	RSTN hold time	2		ns	1

Notes:

- 1) RSTN signal can be asynchronous to the CLOCK signal. It is internally synchronized to the rising edge of CLOCK.

9.0 PACKAGE SPECIFICATIONS

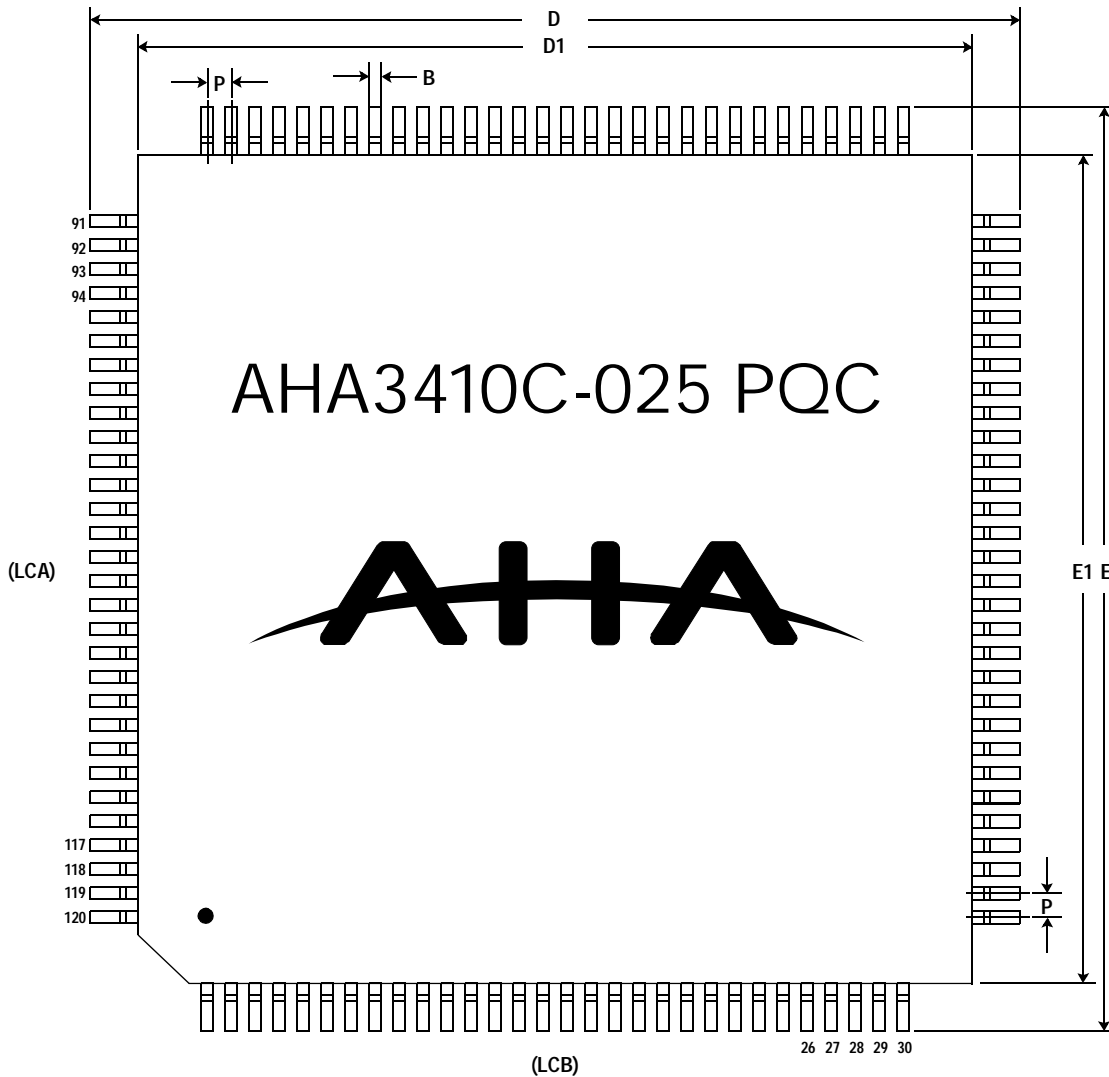
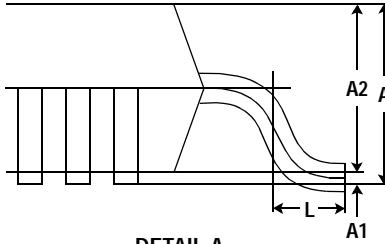
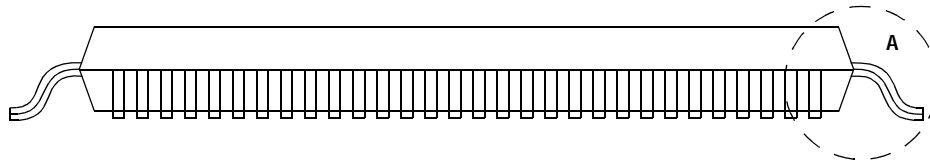

Package is JEDEC MO-108

PLASTIC QUAD FLAT PACK PACKAGE DIMENSIONS
 (All dimensions are in mm)

SYMBOL	NUMBER OF PIN AND SPECIFICATION DIMENSION		
	120		
	SB		
	MIN	NOM	MAX
(LCA)	30		
(LCB)	30		
A		3.7	4.07
A1	0.25	0.33	
A2	3.2	3.37	3.6
D	30.95	31.2	31.45
D1	27.99	28	28.12
E	30.95	31.2	31.45
E1	27.99	28	28.12
L	0.73	0.88	1.03
P		0.8	
B	0.3	0.35	0.4

JEDEC Outline MO-108

10.0 ORDERING INFORMATION

10.1 AVAILABLE PARTS

PART NUMBER	DESCRIPTION
AHA3410C-025 PQC	25 MBytes/sec Simultaneous Lossless Data Compression/Decompression Coprocessor IC

10.2 PART NUMBERING

AHA	3410	C-	025	P	Q	C
Manufacturer	Device Number	Revision Level	Speed Designation	Package Material	Package Type	Test Specification

Device Number:

3410

Revision Letter:

C

Package Material Codes:

P Plastic

Package Type Codes:

Q Quad Flat Pack

Test Specifications:

C Commercial 0°C to +70°C

11.0 RELATED PUBLICATIONS

11.1 AHA TECHNICAL PUBLICATIONS

DOCUMENT #	DESCRIPTION
PB3410C	AHA Product Brief – AHA3410C StarLite™ 25 MBytes/sec Simultaneous Lossless Data Compression/Decompression Coprocessor IC
PB3411	AHA Product Brief – AHA3411 StarLite™ 33 MBytes/sec Simultaneous Compressor/Decompressor IC
PB3422	AHA Product Brief – AHA3422 StarLite™ 16 MBytes/sec Lossless Decompressor IC
PB3431	AHA Product Brief – AHA3431 StarLite™ 40 MBytes/sec Simultaneous Compressor/Decompressor IC, 3.3V
PS3411	AHA Product Specification – AHA3411 StarLite™ 33 MBytes/sec Simultaneous Compressor/Decompressor IC
PS3422	AHA Product Specification – AHA3422 StarLite™ 16 MBytes/sec Lossless Decompressor IC
PS3431	AHA Product Specification – AHA3431 StarLite™ 40 MBytes/sec Simultaneous Compressor/Decompressor IC, 3.3V
ANDC12	AHA Application Note – AHA3410 StarLite™ Designer's Guide
ANDC13	AHA Application Note – Compression Performance on Bitonal Images
ANDC14	AHA Application Note – StarLite™ Evaluation Software
ANDC15	AHA Application Note – ENCODEB2 Compression Algorithm Description
ANDC16	AHA Application Note – Designer's Guide for StarLite™ Family Products: AHA3411, AHA3422 and AHA3431
ANDC17	AHA Application Note – StarLite™ Compression on Continuous Tone Images
GLGEN1	General Glossary of Terms
STARSW	StarLite™ Evaluation Software (Windows™)
PCTP127	T. Summers, "Applying Compression/Decompression in High-Performance Printers and Copiers", Conference Proceeding: <i>The 1995 Silicon Valley Personal Computer Design Conference and Exposition</i>
	T. Summers, "Compression Technologies in Printers", A paper presentation at Seybold Conference, 1995

* Evaluation Software is also available for UNIX operating system, upon request.

11.2 OTHER TECHNICAL PUBLICATIONS

DOCUMENT #	DESCRIPTION
7th Edition, 1995	AMD's Fusion29K® Catalog
6th Edition, 1995	Intel's Solutions 960® Catalog
1996 Edition	Motorola's 68K & ColdFIRE® Source Book: High Performance Embedded Systems

APPENDIX A: ADDITIONAL TIMING DIAGRAMS FOR DMA MODE TRANSFERS

Figure A1: DMA Mode Timing for Single Word Writes, Strobe Condition of DSC=000

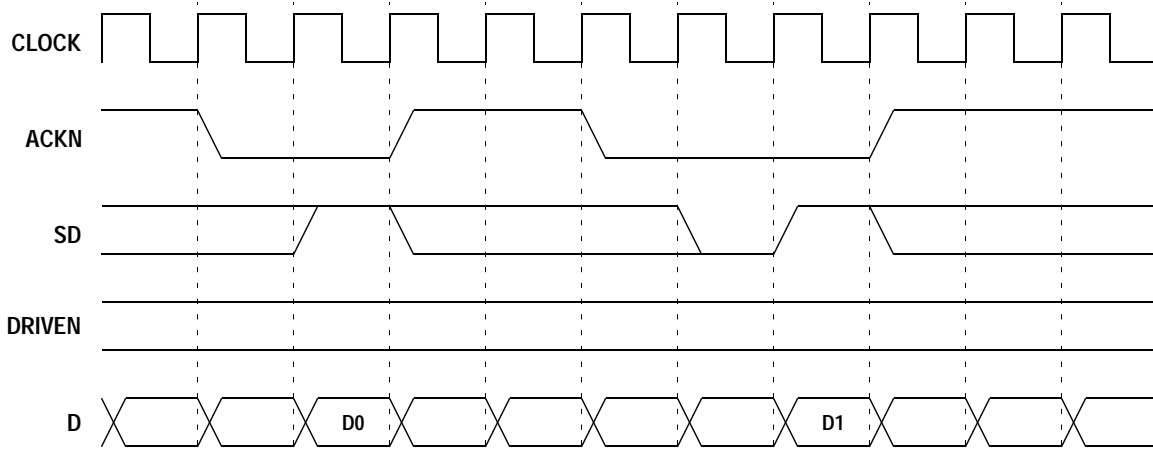

Figure A2: DMA Mode Timing for Single Word Reads, Strobe Condition of DSC=000

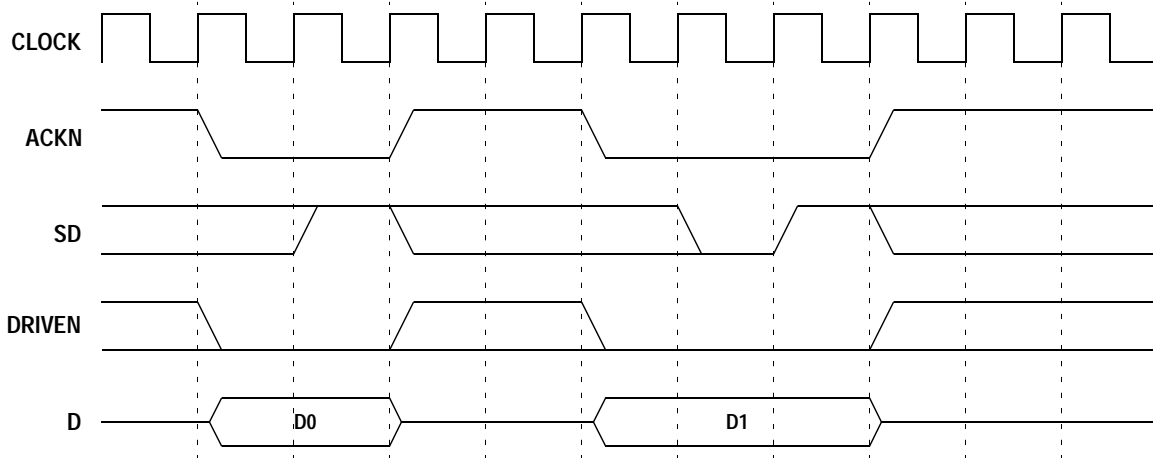

Figure A3: DMA Mode Timing for Four Word Burst Write, One Wait State, Strobe Condition of DSC=000

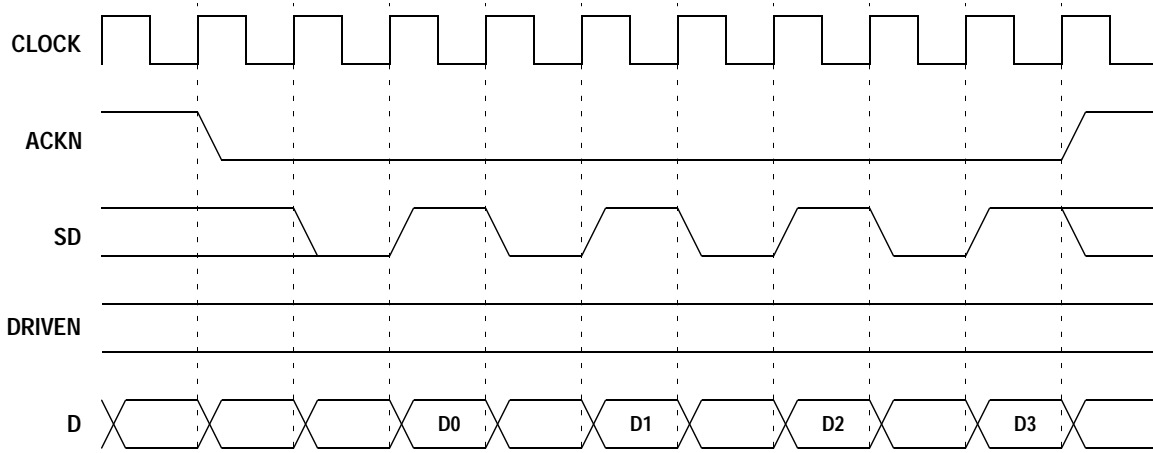

Figure A4: DMA Mode Timing for Four Word Burst Read, One Wait State, Strobe Condition of DSC=000

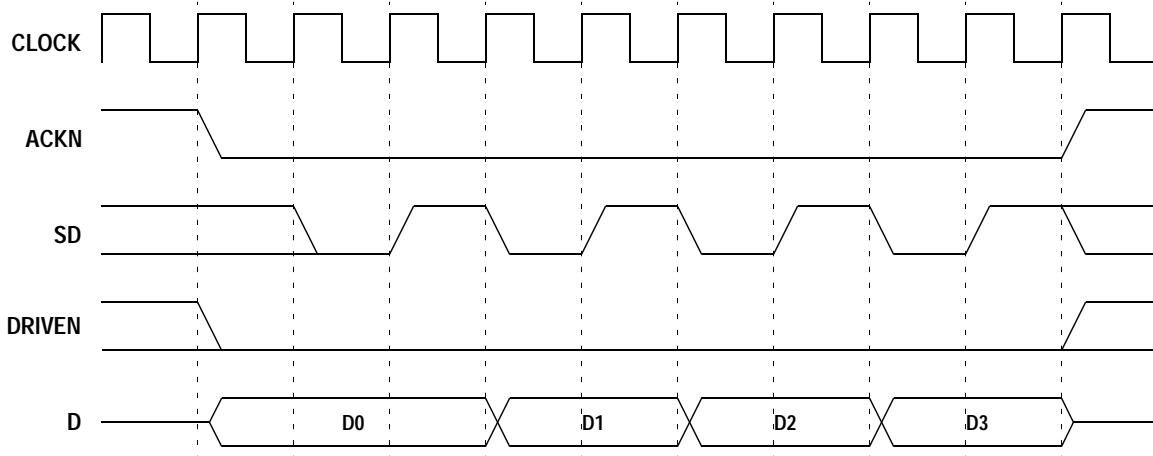

Figure A5: DMA Mode Timing for Eight Word Burst Write, Zero Wait State, Strobe Condition of DSC=000

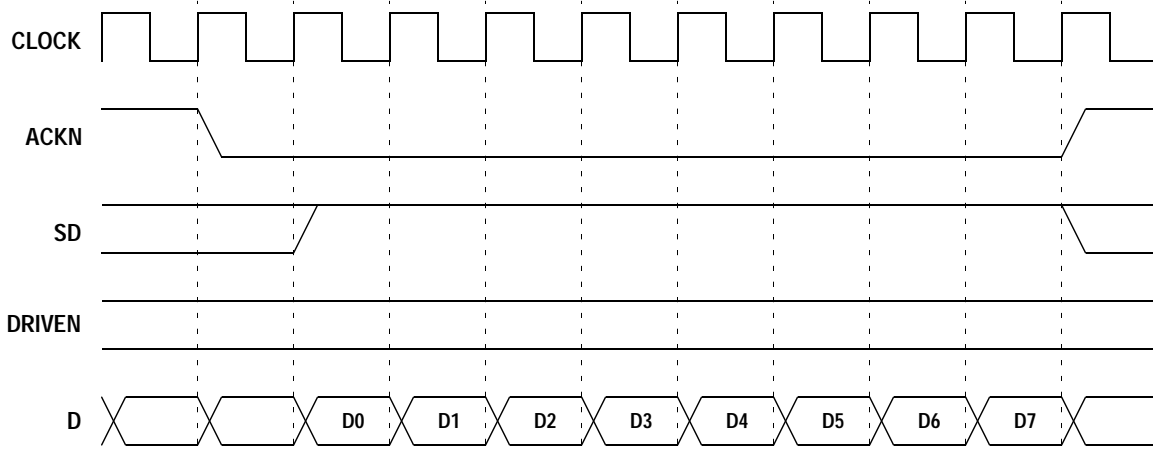

Figure A6: DMA Mode Timing for Eight Word Burst Read, Zero Wait State, Strobe Condition of DSC=000

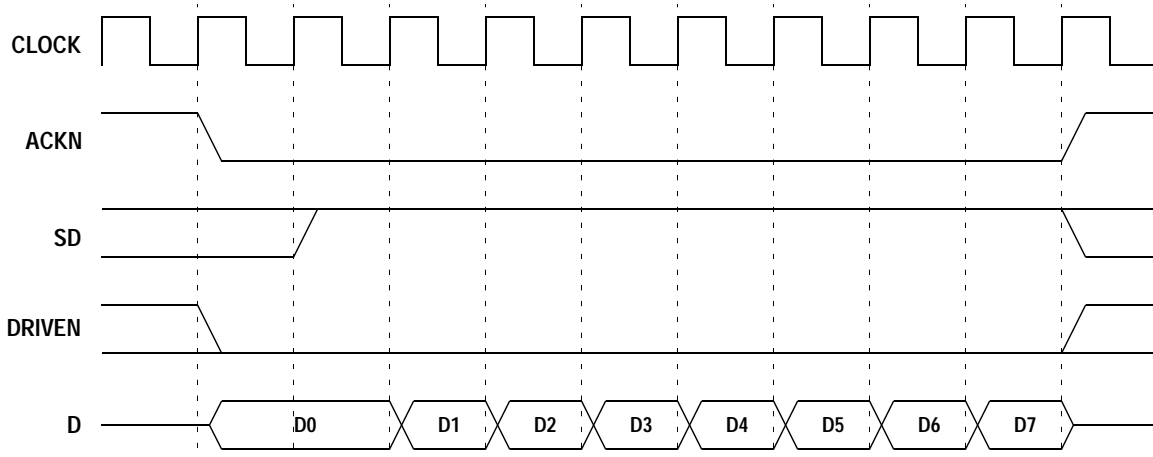

Figure A7: DMA Mode Timing for Single Word Writes, Strobe Condition of DSC=010

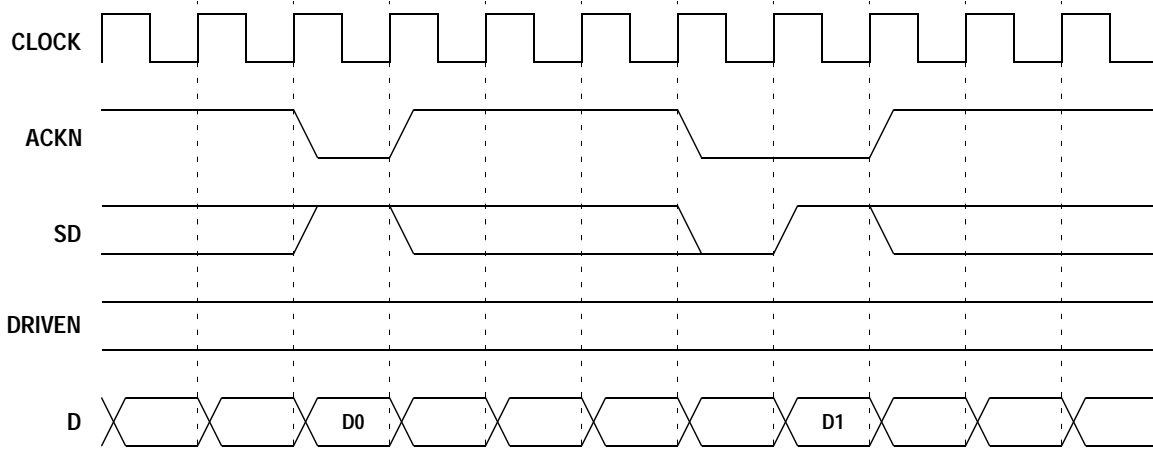

Figure A8: DMA Mode Timing for Single Word Reads, Strobe Condition of DSC=010

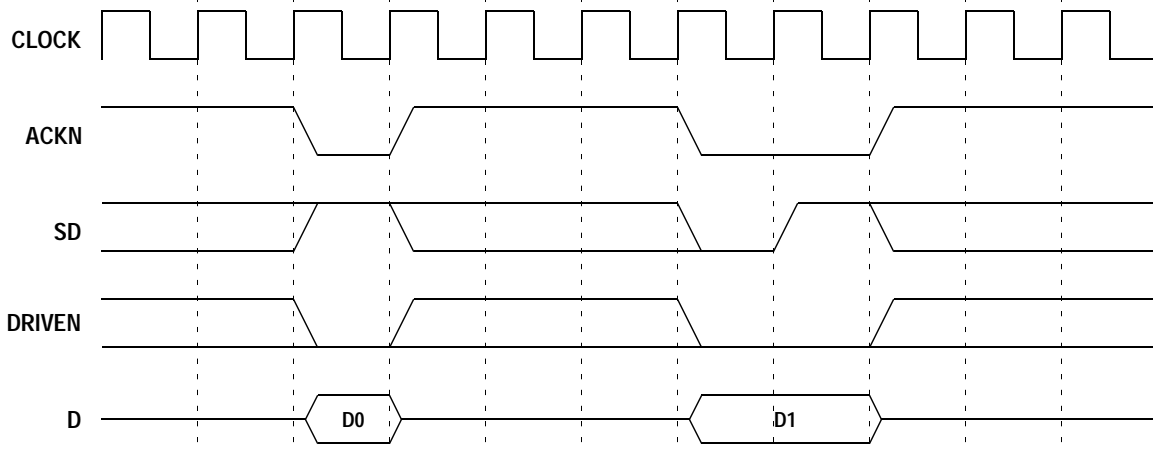

Figure A9: DMA Mode Timing for Four Word Burst Write, One Wait State, Strobe Condition of DSC=010

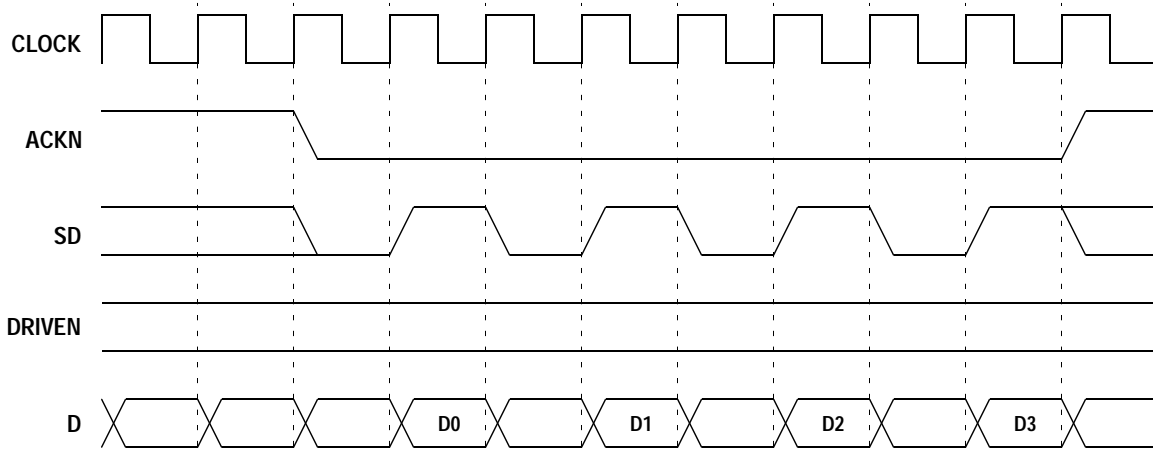

Figure A10: DMA Mode Timing for Four Word Burst Read, One Wait State, Strobe Condition of DSC=010

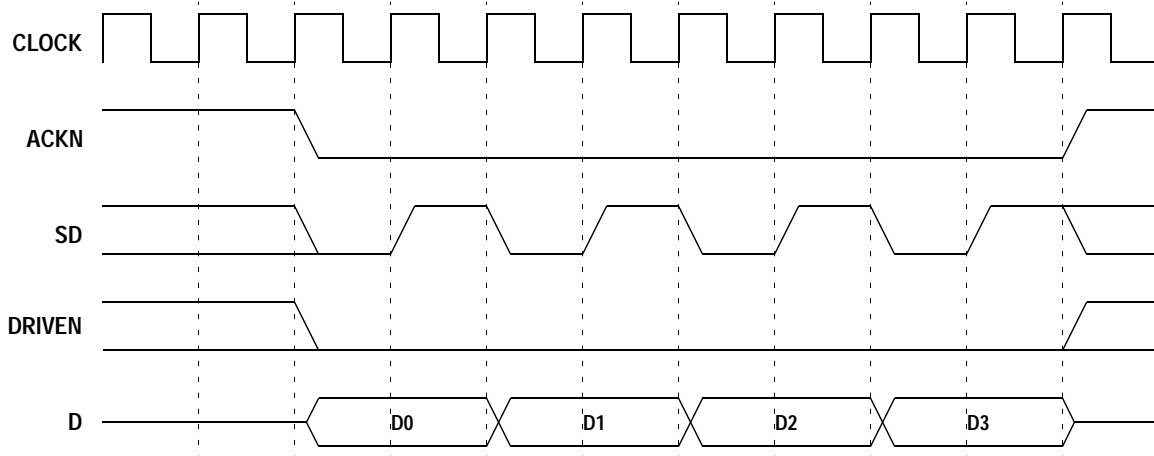

Figure A11: DMA Mode Timing for Eight Word Burst Write, Zero Wait State, Strobe Condition of DSC=010

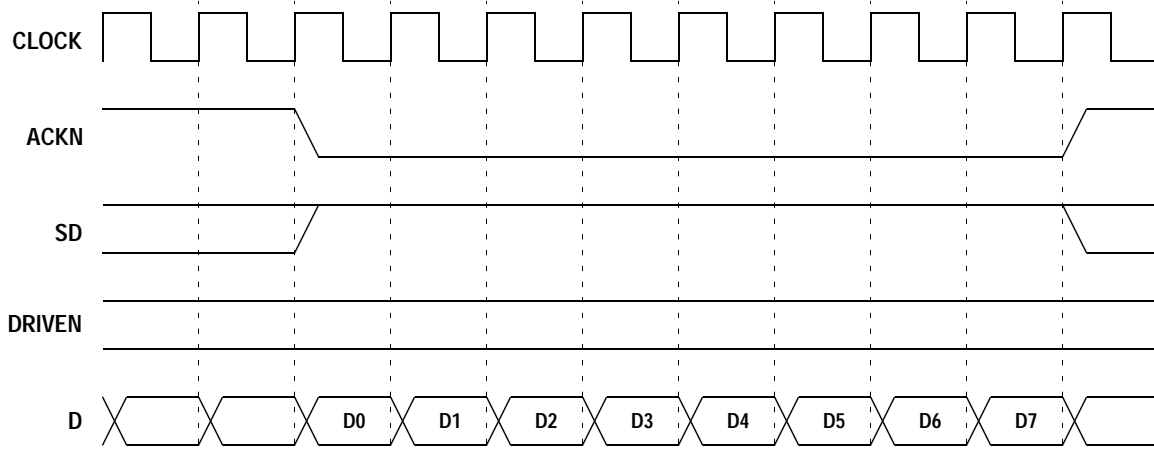

Figure A12: DMA Mode Timing for Eight Word Burst Read, Zero Wait State, Strobe Condition of DSC=010

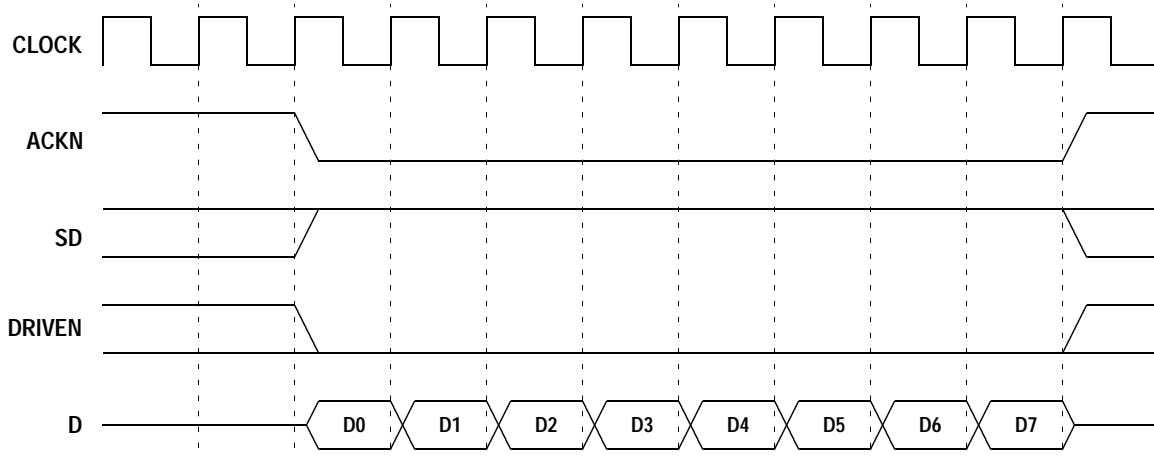

Figure A13: DMA Mode Timing for Single Word Writes, Strobe Condition of DSC=011

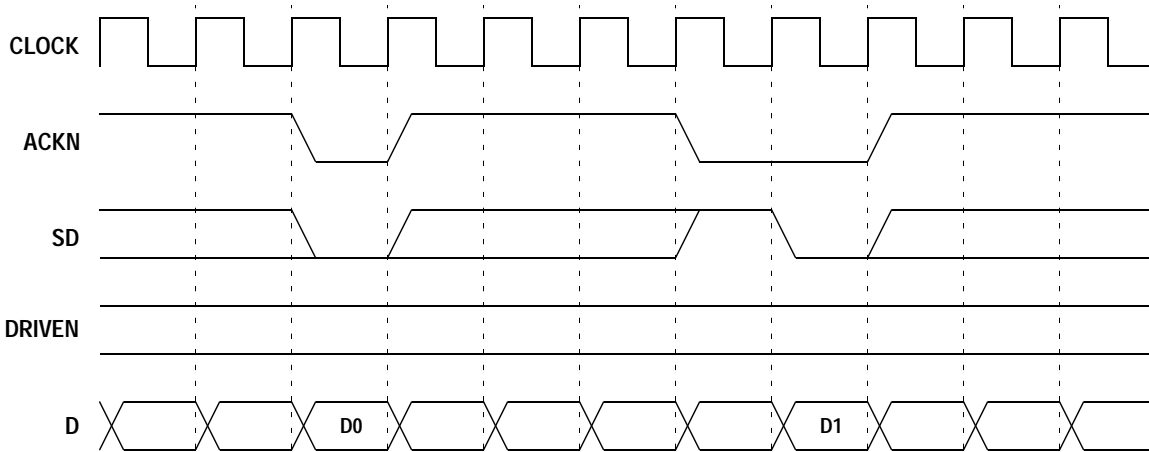

Figure A14: DMA Mode Timing for Single Word Reads, Strobe Condition of DSC=011

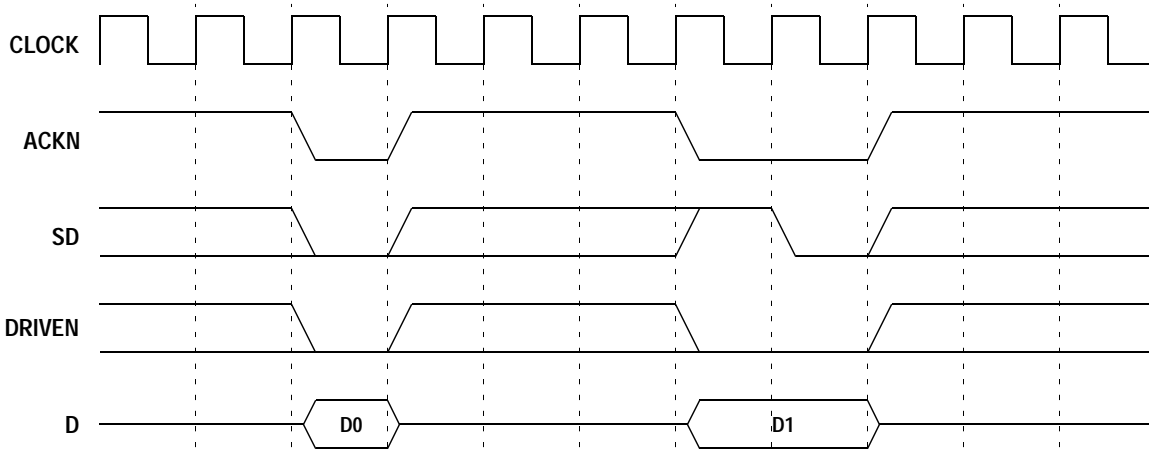

Figure A15: DMA Mode Timing for Four Word Burst Write, One Wait State, Strobe Condition of DSC=011

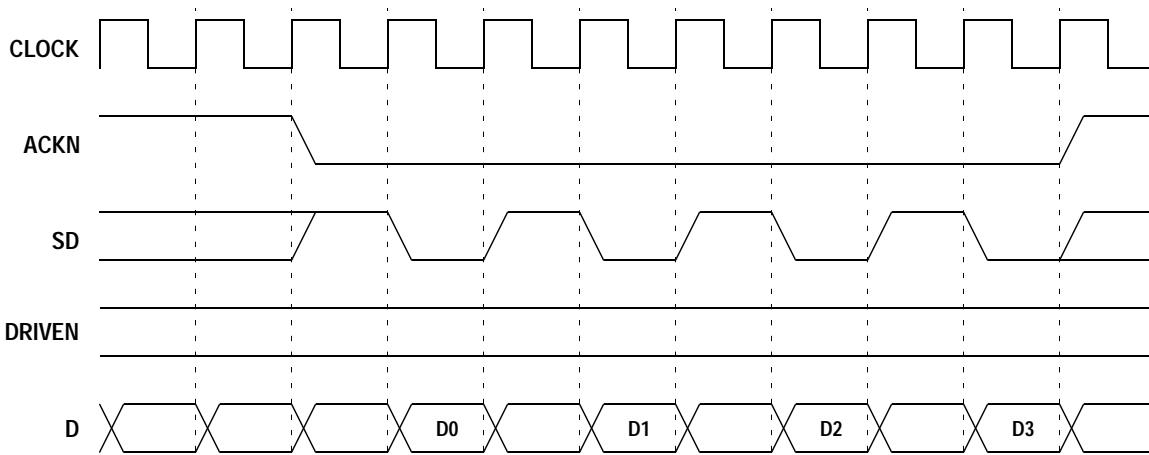

Figure A16: DMA Mode Timing for Four Word Burst Read, One Wait State, Strobe Condition of DSC=011

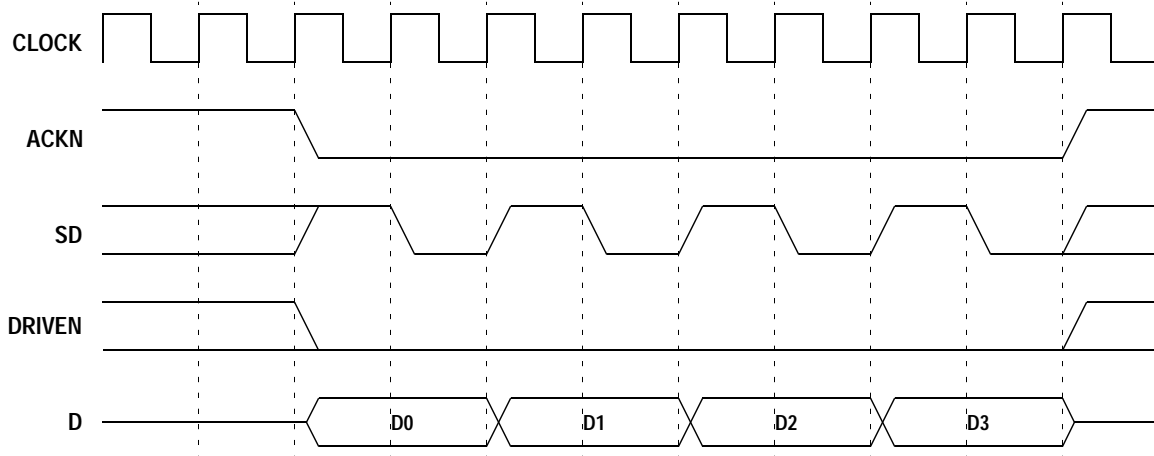

Figure A17: DMA Mode Timing for Eight Word Burst Write, Zero Wait State, Strobe Condition of DSC=011

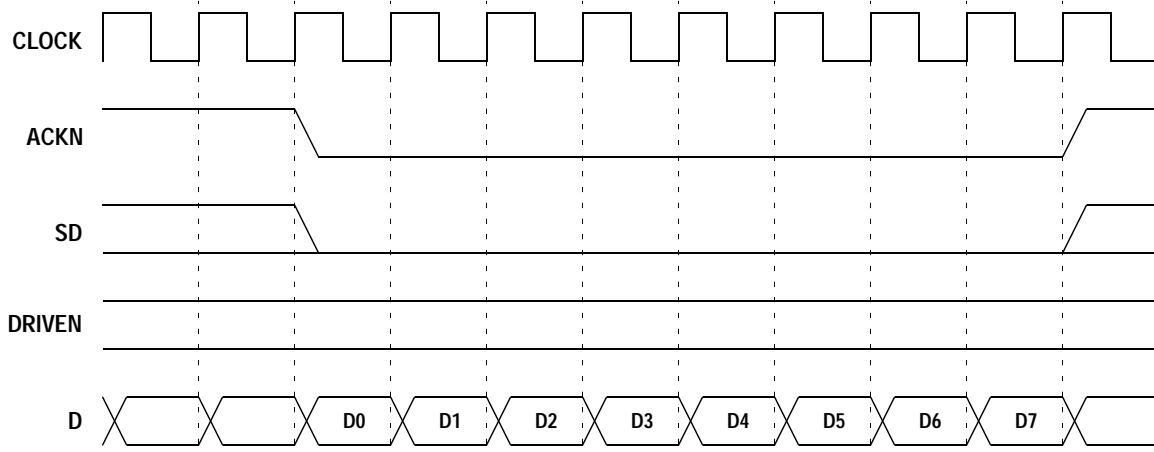

Figure A18: DMA Mode Timing for Eight Word Burst Read, Zero Wait State, Strobe Condition of DSC=011

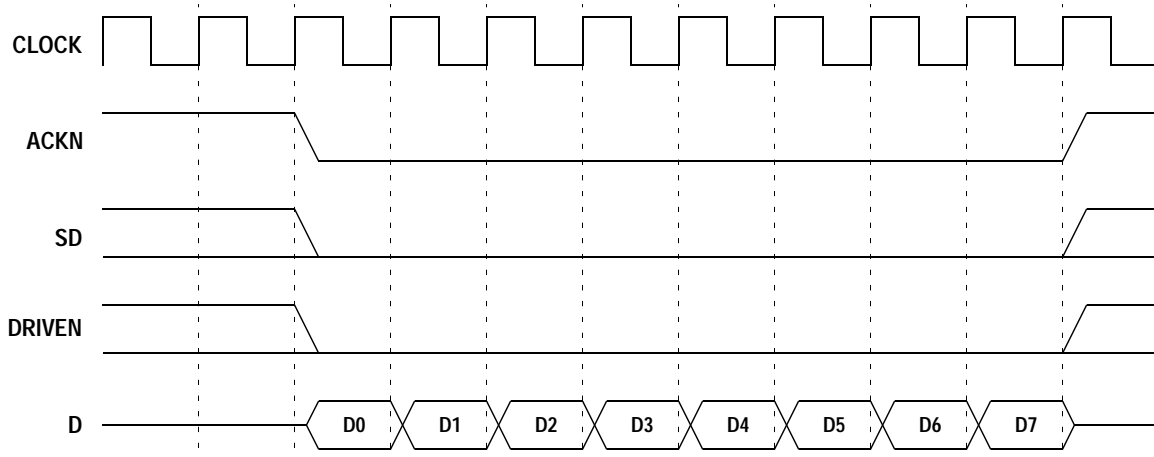

Figure A19: DMA Mode Timing for Single Word Writes, Strobe Condition of DSC=111

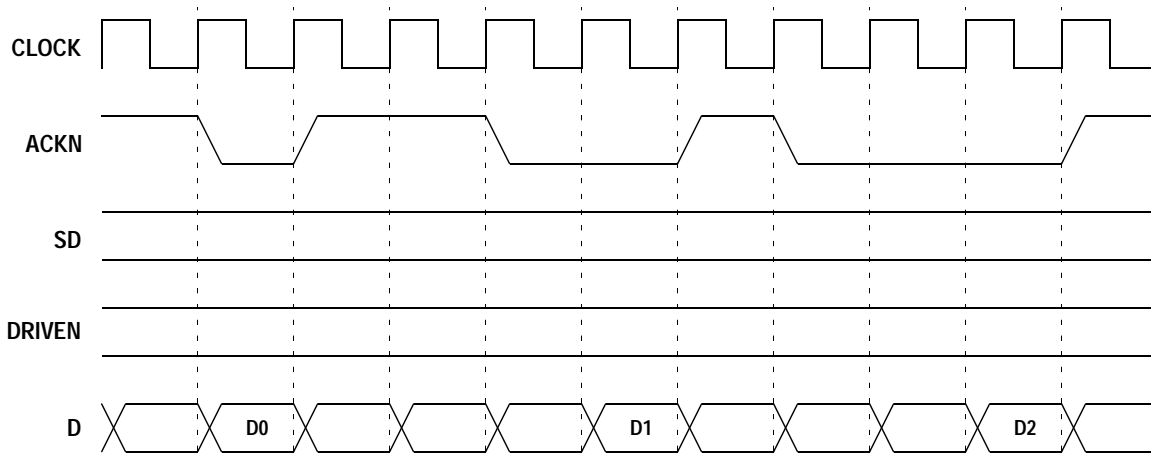

Figure A20: DMA Mode Timing for Single Word Reads, Strobe Condition of DSC=111

