

CONFIDENTIAL



# TFT-LCD MONITOR

## MO15E\*

# *SERVICE* Manual

### TFT-LCD MONITOR

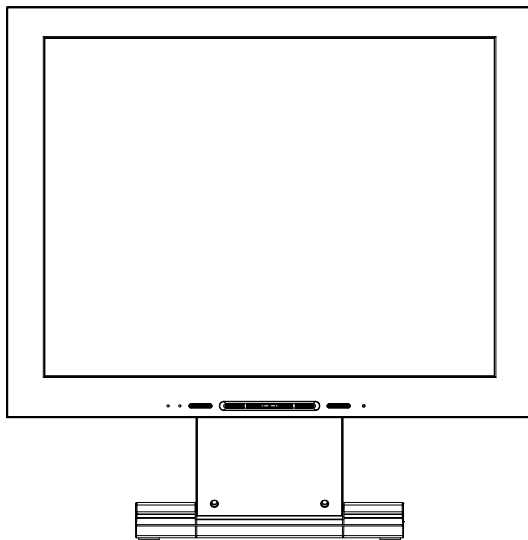

### CONTENTS

1. Precautions
2. Product Specifications
3. Disassembly & Reassembly
4. Troubleshooting
5. Exploded View & Parts List
6. Electrical Parts List
7. Block Diagram
8. Wiring Diagram
9. Schematic Diagrams
10. Panel Description

# 1 Precautions

Follow these safety, servicing and ESD precautions to prevent damage and to protect against potential hazards such as electrical shock.

## 1-1 Safety Precautions

### 1-1-1 Warnings

1. For continued safety, do not attempt to modify the circuit board.
2. Disconnect the AC power and DC Power Jack before servicing.
3. When the chassis is operating, semiconductor heatsinks are potential shock hazards.

### 1-1-2 Servicing the LCD Monitor

1. When servicing the LCD Monitor, remove the static charge by connecting a 10k ohm resistor in series with an insulated wire (such as a test probe) between the chassis and the anode lead. (Disconnect the AC line cord from the AC outlet.)
2. It is essential that service technicians have an accurate voltage meter available at all times. Check the calibration of this meter periodically.

### 1-1-3 Fire and Shock Hazard

Before returning the monitor to the user, perform the following safety checks:

1. Inspect each lead dress to make certain that the leads are not pinched or that hardware is not lodged between the chassis and other metal parts in the monitor.
2. Inspect all protective devices such as nonmetallic control knobs, insulating materials, cabinet backs, adjustment and compartment covers or shields, isolation resistor-capacitor networks, mechanical insulators, etc.
3. Leakage Current Hot Check (Figure 1-1):  
**WARNING: Do not use an isolation transformer during this test.**  
 Use a leakage current tester or a metering system that complies with American National Standards Institute (*ANSI C101.1, Leakage Current for Appliances*), and Underwriters Laboratories (*UL Publication UL1410, 59.7*).

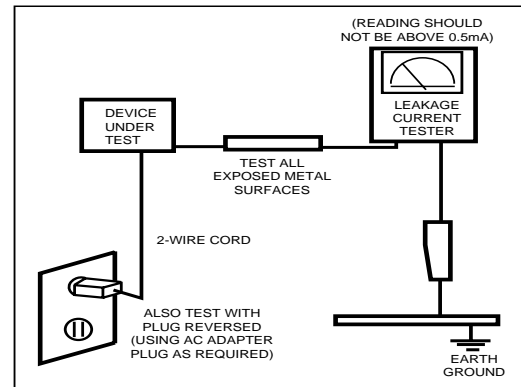

Figure 1-1. Leakage Current Test Circuit

4. With the unit completely reassembled, plug the AC line cord directly into a 120V AC outlet. With the unit's AC switch first in the ON position and then OFF, measure the current between a known earth ground (metal water pipe, conduit, etc.) and all exposed metal parts, including: metal cabinets, screwheads and control shafts. The current measured should not exceed 0.5 milliamp. Reverse the power-plug prongs in the AC outlet and repeat the test.

### 1-1-4 Product Safety Notices

Some electrical and mechanical parts have special safety-related characteristics which are often not evident from visual inspection. The protection they give may not be obtained by replacing them with components rated for higher voltage, wattage, etc. Parts that have special safety characteristics are identified by ⚠ on schematics and parts lists. A substitute replacement that does not have the same safety characteristics as the recommended replacement part might create shock, fire and / or other hazards. Product safety is under review continuously and new instructions are issued whenever appropriate.

## 2 Product Specifications

### 2-1 Specifications

Item	Description
LCD Panel	TFT-LCD panel, RGB vertical stripe, normally white, 15-Inch viewable, 0.297 mm pixel pitch
Scanning Frequency	Horizontal : 31 kHz ~ 60 kHz (Automatic) Vertical : 56 Hz ~ 75 Hz (Automatic)
Display Colors	16.2 M
Maximum Resolution	Horizontal : 1024 Pixels                      Vertical : 768 Pixels
Input Video Signal	Analog, 0.7 Vp-p ± 1% positive at 75 $\Omega$ , internally terminated
Input Sync Signal	Type : Seperate H/V sync, Composite H/V, Sync-on-Green, automatic synchronization without external switch of sync type Level : TTL level
Maximum Pixel Clock rate	80 MHz
Active Display Horizontal/Vertical	304.1 mm / 228.1 mm
AC power voltage & Frequency	AC 90 ~ 264 Volts, 60/50 Hz ~ 12 V/3 A
Power Consumption	30 W (MAX)
Dimensions / Unit Weight / incl. Carton Unit (W x D x H) Carton (W x D x H)	357.5 x 184.5 x 360.6 mm (14.1 x 7.3 x 14.2 inches) 440 x 363 x 145 mm (17.3 x 14.3 x 5.7 inches)
Weight (Net/Gross) Normal Stand Multi Stand	2.9 kg (6.4 lbs) / 4.6 kg (10.1 lbs) 2.98 kg (6.6 lbs) / 4.68 kg (10.3 lbs)
Environmental Considerations	Operating Temperature : 50 °F ~ 104 °F (10 °C ~ 40 °C) Humidity : 10 % ~ 80 % Storage Temperature : 13 °F to 113 °F (-25 °C ~ 45 °C) Humidity : 5 % ~ 95 %
<ul style="list-style-type: none"> <li>• M015E* complies with SWEDAC (MPR II) recommendations for reduced electromagnetic fields.</li> <li>• Designs and specifications are subject to change without prior notice.</li> </ul>	

## 3 Disassembly and Reassembly

This section of the service manual describes the disassembly and reassembly procedures for the MO15E\* monitors.

**WARNING:** This monitor contains electrostatically sensitive devices. Use caution when handling these components.

### 3-1 Disassembly

- Cautions:**
1. Disconnect the monitor from the power source before disassembly.
  2. Follow these directions carefully; never use metal instruments to pry apart the cabinet.

#### 3-1-1 Main Body Disassembly



1. Locate the monitor on the table with face down.



2. Loosen the snaps of Hinge cap through the slot of Cover Rear.



3. Remove the hinge cap.

## 4 Troubleshooting

- Notes:**
1. Before troubleshooting, setup the PC's display as below.
    - Resolution: 1024 x 768
    - H-frequency: 48 kHz
    - V-frequency: 60 Hz
  2. If no picture appears, make sure the power cord is correctly connected.
  3. Check the following circuits.
    - No raster appears: SMPS PCB, Main PCB
    - 14V develop but no screen: Main PCB
    - 14V does not develop: SMPS PCB
  4. If you push and hold the "EXIT" button for more than 5 seconds, the monitor automatically turns back to the factory preset.

### 4-1 No Power

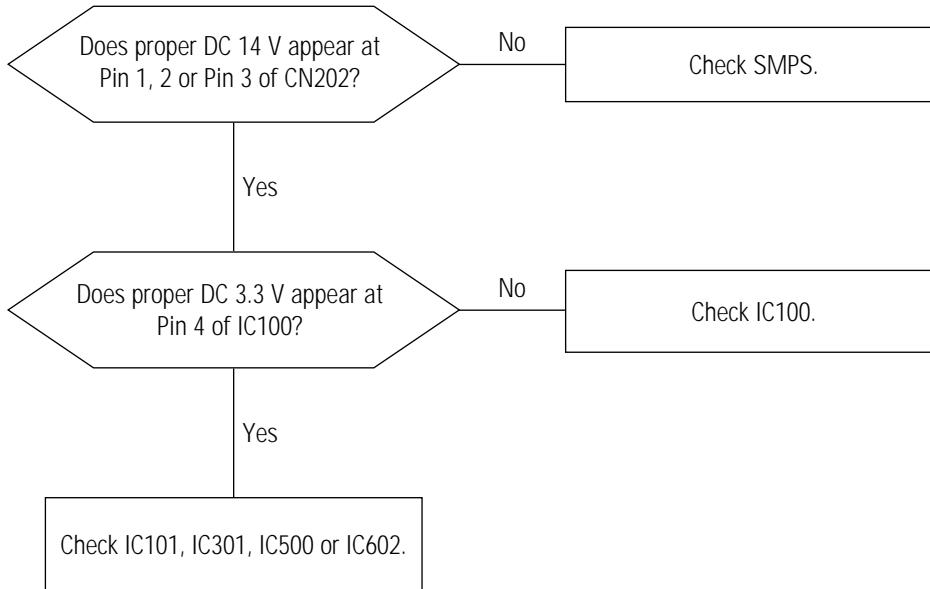

### 5 Exploded View and Parts List

No.	DESCRIPTION	CODE No.	SPECIFICATION	Q'ty	REMARKS	
1	ASSY, COVER-FRONT	BN90-00053B	ABS HB BK07+SILVER SPRAY	1		S A
2	SCREW-TAPTITE	6003-000276	BH, +, B, M3, L10	4	PANEL+ASSY, REAR	S A
3	PANEL	-	M015PS	1		-
4	SHEET-PLATE	BN72-00307A	ABS+PC IV16	1		S N A
5	ASSY, SHIELD-PCB	BN90-00055A	SECC T0.5	1		S A
6	SCREW-MACHINE	-	?, +, M2, L6	2	B/GROUND+AD BOARD+S/PLATE	-
7	BRKT-GROUND	BN70-000264A	SECC T0.8	1		S N A
8	SCREW-TAPTITE	6003-000117	BH, +, B, M3, L6	3	S/PCB+B/GROUN(or INVERTER PCB)	S A
9	ASSY, COVER-REAR	BN90-00054A	ABS HB BK07	1		S A
10	SCREW-TAPTITE	6003-000259	BH, +, B, M3, L8	2	ASSY, REAR+ASSY, FRONT	S A
11-1	ASSY, STAND	BN90-00056B	M015PS	1	NOMAL STAND	S A
11-2	ASSY, STAND	BN90-00056C	M015PS	1	MULTI STAND	S A
12	SHIELD-CONNECTOR	BN70-00263A	SPT E T0.3	1		S N A
13	SCREW-MACHINE	-	?, +, M4, L6	3	S/CONNECTOR+ASSY, STAND+ASSY, REAR	-
14	CAP-STAND	BN72-00310A	ABS HB BK07	1		S N A

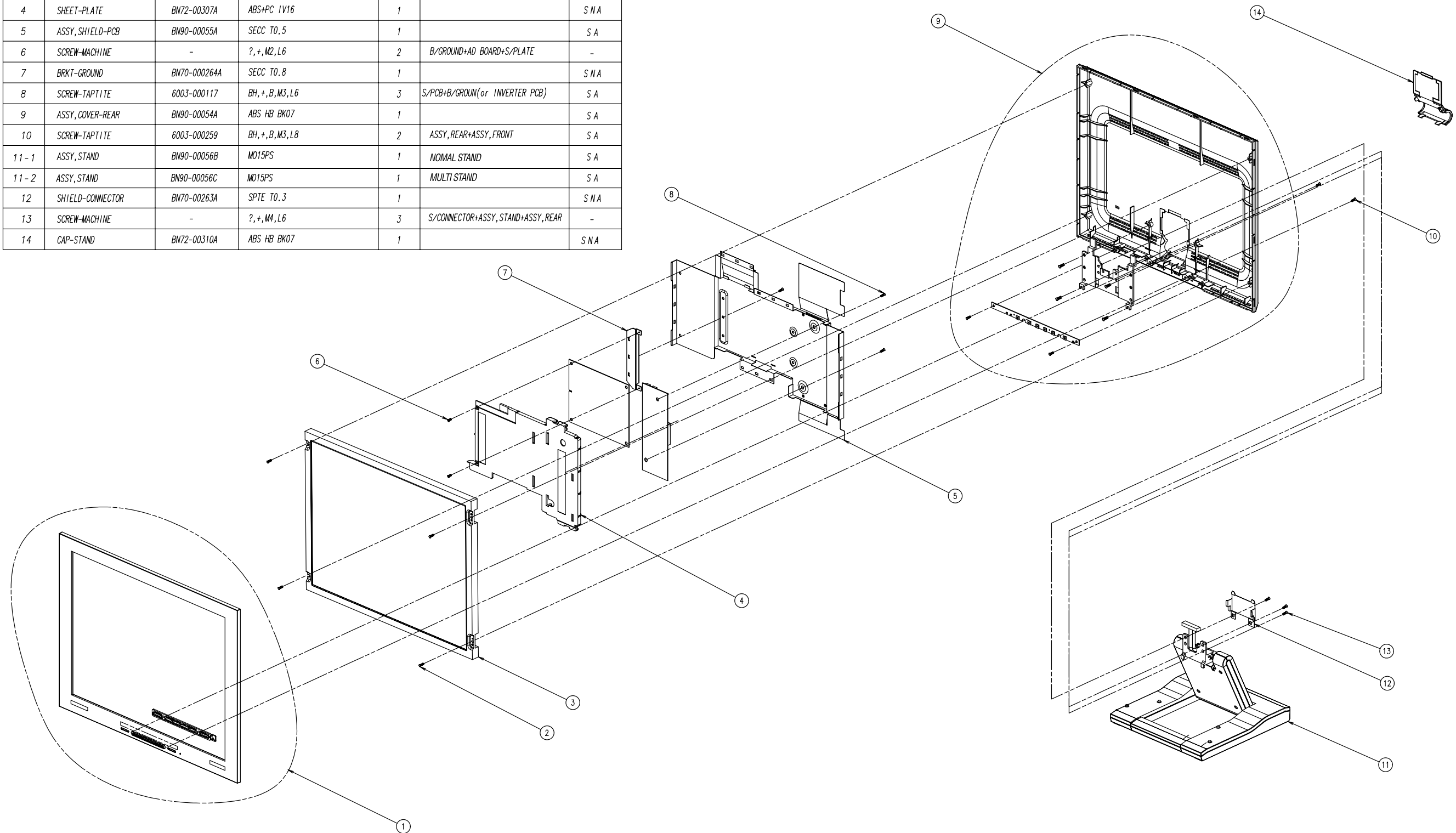

## 6 Electrical Parts List

### 6-1 Main PCB Parts

Loc. No.	Code No.	Description	Specification	Remarks
-	BN94-00302A	ASSY PCB MAIN	MO15ES	SNA
CIS	BH73-60304E	RUBBER-SUPPORT	MO15PS,CR V0,6*6*6.4,BLACK	SNA
CIS	BN39-00002A	CBF-HARNESS	-,60,BLU/WHT,-,26,-	SNA
CIS	BN39-00251A	LEAD CONNECTOR ASSY	MO15ES,UL1571#30,UL/CSA,20P,#30,12507HS-20,12507HS-20,BK,40MM,1571#30,SJ01-01-33	
CIS	BN44-00066A	INVERTER	MO15PS,SIC581,48KHZ,14VDC,2.6MARMS,6.1MARMS,48KHZ,140*50*8.0,4LAMP	
CIS	BN70-00264A	PLATE-BRKT GROUND	MO15PS,SECC,-,T0.8,-,-,-,-,MO15PS	SNA
CIS	BN72-00307A	PLATE-PCB	MO15PS,ABS+PC,IV16,-,-,5V,-,-,-	SNA
CIS6	BN63-00265A	GASKET	MO15PS,CONDUCTIVE FABLIC,4MM,10MM,17MM,GRAY,71TSSK 10-4-17-13,71TSSK 10-4-17-13	SNA
CIS7	BN63-00266A	GASKET	MO15PS,CONDUCTIVE FABLIC,4MM,4MM,60MM,GRAY,71TSSK 4-4-60-13,71TSSK 4-4-60-13	SNA
SHIMD-BR/GR-PCB	6001-001340	SCREW-MACHINE	CH,+M2.0,L4.5,ZPC(YEL),SWRCH18A,FP	
-	BN97-00094A	ASSY SMD	MO15ES	SNA
C100	2402-001042	C-AL,SMD	100uF,20%,16V,GP,TP,6.6x6.6x5.4mm	
C101	2203-005005	C-CERAMIC,CHIP	100nF,10%,16V,X7R,TP,1608	
C102	2402-001042	C-AL,SMD	100uF,20%,16V,GP,TP,6.6x6.6x5.4mm	
C103	2402-001042	C-AL,SMD	100uF,20%,16V,GP,TP,6.6x6.6x5.4mm	
C104	2203-005005	C-CERAMIC,CHIP	100nF,10%,16V,X7R,TP,1608	
C105	2203-001652	C-CERAMIC,CHIP	470nF,+80-20%,16V,Y5V,TP,1608	
C106	2203-001652	C-CERAMIC,CHIP	470nF,+80-20%,16V,Y5V,TP,1608	
C107	2402-001042	C-AL,SMD	100uF,20%,16V,GP,TP,6.6x6.6x5.4mm	
C200	2402-001042	C-AL,SMD	100uF,20%,16V,GP,TP,6.6x6.6x5.4mm	
C201	2203-000189	C-CERAMIC,CHIP	100nF,+80-20%,25V,Y5V,TP,1608,	
C202	2203-000236	C-CERAMIC,CHIP	0.1nF,5%,50V,NPO,TP,1608	
C203	2203-000236	C-CERAMIC,CHIP	0.1nF,5%,50V,NPO,TP,1608	
C204	2203-005005	C-CERAMIC,CHIP	100nF,10%,16V,X7R,TP,1608	
C205	2203-000815	C-CERAMIC,CHIP	0.033nF,5%,50V,NPO,TP,1608	
C206	2203-000626	C-CERAMIC,CHIP	0.022nF,5%,50V,NPO,TP,1608	
C208	2203-005005	C-CERAMIC,CHIP	100nF,10%,16V,X7R,TP,1608	
C210	2203-005005	C-CERAMIC,CHIP	100nF,10%,16V,X7R,TP,1608	
C212	2203-005005	C-CERAMIC,CHIP	100nF,10%,16V,X7R,TP,1608	
C213	2203-000384	C-CERAMIC,CHIP	0.015nF,5%,50V,NPO,TP,1608	
C214	2203-000384	C-CERAMIC,CHIP	0.015nF,5%,50V,NPO,TP,1608	
C215	2203-000384	C-CERAMIC,CHIP	0.015nF,5%,50V,NPO,TP,1608	
C216	2203-005005	C-CERAMIC,CHIP	100nF,10%,16V,X7R,TP,1608	
C217	2402-000108	C-AL,SMD	10uF,20%,16V,WT,TP,4.3x4.3x5.4	
C218	2203-005005	C-CERAMIC,CHIP	100nF,10%,16V,X7R,TP,1608	
C219	2203-000257	C-CERAMIC,CHIP	10nF,10%,50V,X7R,TP,1608	
C220	2402-000108	C-AL,SMD	10uF,20%,16V,WT,TP,4.3x4.3x5.4	
C300	2402-000135	C-AL,SMD	22uF,20%,16V,GP,TP,5.3x5.3x5.4	
C301	2203-005005	C-CERAMIC,CHIP	100nF,10%,16V,X7R,TP,1608	
C302	2203-005005	C-CERAMIC,CHIP	100nF,10%,16V,X7R,TP,1608	
C303	2203-005005	C-CERAMIC,CHIP	100nF,10%,16V,X7R,TP,1608	
C304	2203-005005	C-CERAMIC,CHIP	100nF,10%,16V,X7R,TP,1608	
C305	2402-000135	C-AL,SMD	22uF,20%,16V,GP,TP,5.3x5.3x5.4	
C306	2203-005005	C-CERAMIC,CHIP	100nF,10%,16V,X7R,TP,1608	
C307	2402-000135	C-AL,SMD	22uF,20%,16V,GP,TP,5.3x5.3x5.4	
C308	2203-005005	C-CERAMIC,CHIP	100nF,10%,16V,X7R,TP,1608	
C309	2203-000041	C-CERAMIC,CHIP	0.01nF,0.25pF,50V,NPO,TP,1608	
C310	2203-000843	C-CERAMIC,CHIP	39nF,10%,25V,X7R,TP,1608,-	

7 Block Diagram

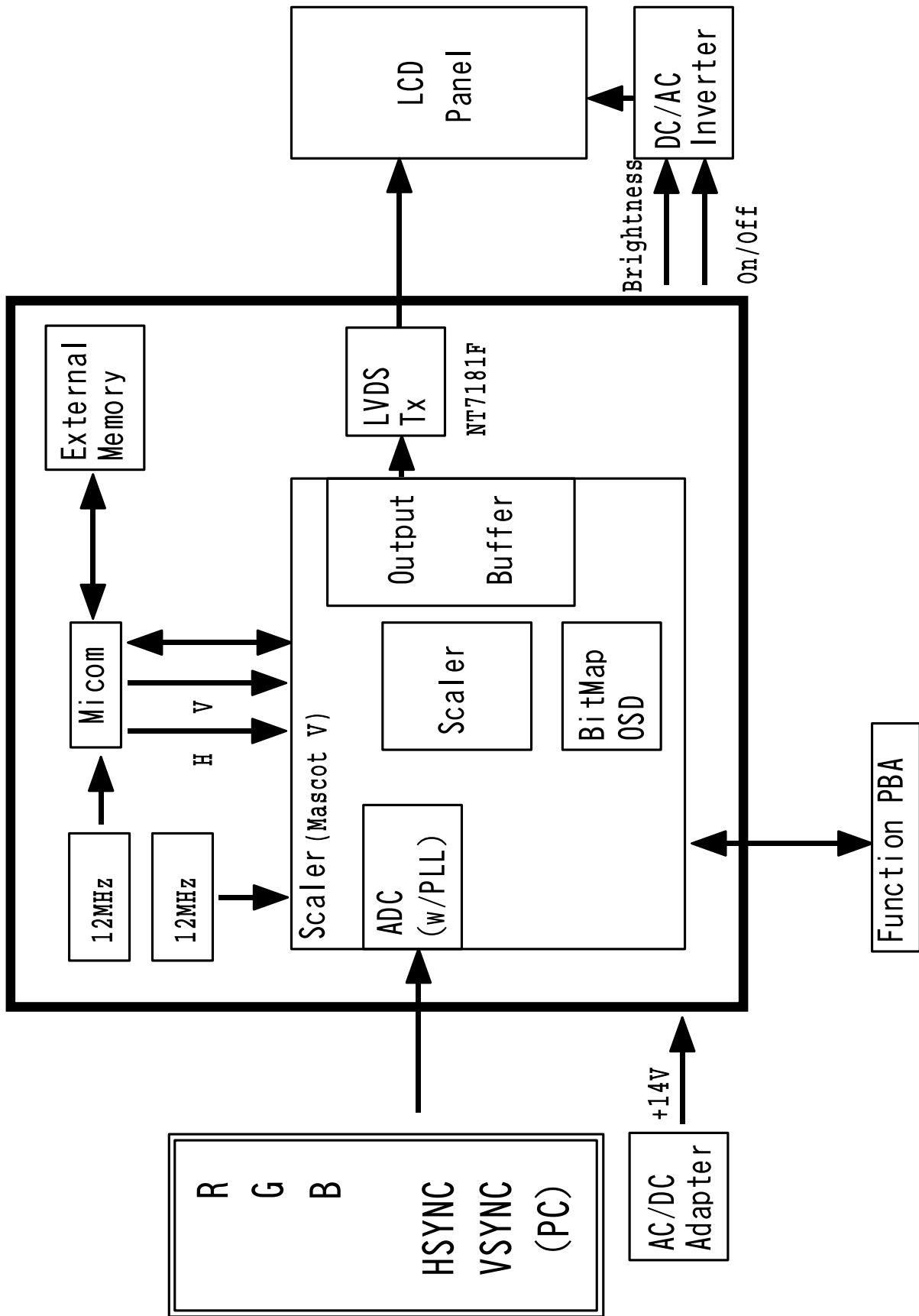



8 Wiring Diagram

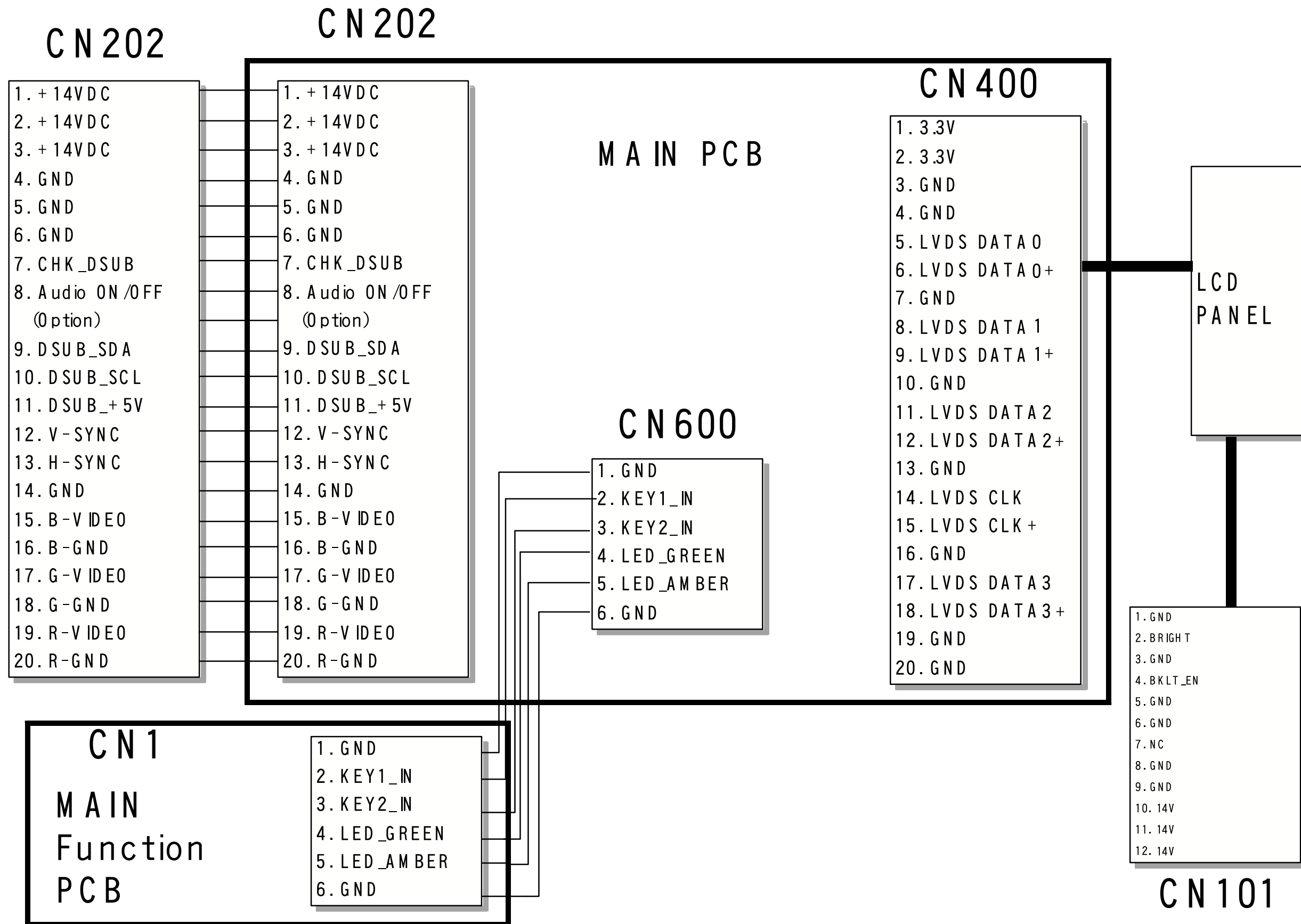

# 9 Schematic Diagrams

## 9-1 Schematic Diagram

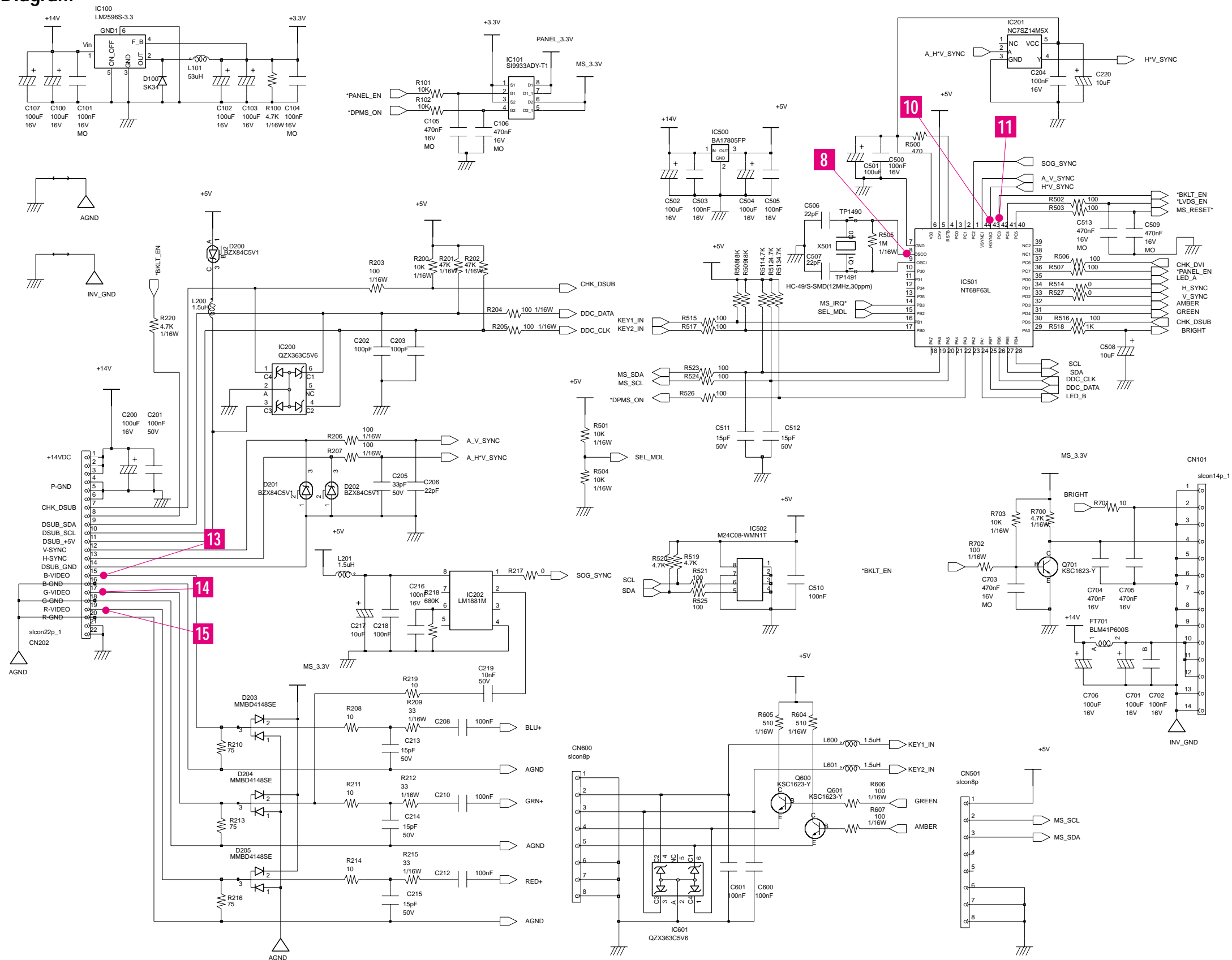

## 10 Panel Description

Maker	VENDOR P/N	PANEL_CODE	PANEL_ABB	STICKER_CODE	Remarks
SEC	LT140X1-002	BN07-00004A	SA	BN68-00187A	
SEC	LT150XS-L01	BN07-00009A	SB	BN68-00187B	
SEC	LT150XS-L01-B	BN07-00022A	SC	BN68-00187C	
SEC	LTM150XS-L02	BN07-00005A	SD	BN68-00187D	
SEC	LT181E2-132	BN07-00001A	SE	BN68-00187E	
SEC	LT150XS-T01	BN07-00010A	SF	BN68-00187F	
SEC	LTM181E3-132	BN07-00019A	SG	BN68-00187G	
SEC	LT170E2-131	BN07-10001D	SH	BN68-00187H	
SEC	LT181E2-131	BN07-10001E	SJ	BN68-00187J	
SEC	LTM170E4-L01	BN07-00018A	SK	BN68-00187K	
SEC	LTM240W1-L01	BN07-00015A	SL	BN68-00187L	
SEC	LTM213U3-L01	BN07-00016A	SM	BN68-00187M	
SEC	LTM150XH-L01	BN07-00026A	SN	BN68-00187W	
SEC	LTM150XH-L03	BN07-00027A	SP	BN68-00187X	
SEC	LTM150XS-L01	BN07-00032A	SQ	BN68-00195B	DELL(ZPD)
SEC	LTM181E4-L01	BN07-00034A	SR	BN68-00195C	PVA
SEC	LTM170EH-L01	BN07-00036A	SS	BN68-00195D	TN
SEC	LTM170E5-L01	BN07-00037A	SU	BN68-00195E	PVA
SEC	LTM150XH-L11	BN07-00041A	SV	BN68-00195G	
SEC	LTM213U4-L01	BN07-00039A	SW	BN68-00195L	PVA
SEC	LTM150XH-L01(ZPD)	BN07-00045A	SX	BN68-00195M	ZPD
SEC	LTM150XH-L04	BN07-00046A	SY	BN68-00195N	PANEL
SEC	LTM170W1-L01	BN07-00047A	SZ	BN68-00195P	TV PANEL
SEC	LTM150XH-L06	BN07-00053A	EA	BN68-00195V	TV PANEL/450cd Sony& EOS panel
SEC	LTM153W1-L01	BN07-00054A	EB	BN68-00195W	NIKE MODEL
SEC	LTM170EH-L05	BN07-00055A	EC	BN68-00195X	17" EH-L05 panel EOS proj.
SEC	LTM170E5-L03	BN07-00056A	ED	BN68-00195Y	Dell 1702FP pro. E4 Compatible
SEC	LTM190E1-L01	BN07-00057A	EE	BN68-00195Z	DELL 1900 FP
SEC	LTM181E5-L01	BN07-00061A	EF	BN68-00239C	18" narrow bezel GH18PS
SEC	LTM150XP-L01	BN07-00065A	EG	BN68-00239F	AMLCD PVA PANEL
SEC	LTM240W1-L02	BN07-00062A	EH	BN68-00239G	15" Wide tv panel
TOSHIBA	LTM15C419(A)	BN07-00002A	TA	BN68-00187N	
TOSHIBA	LTM15C423(B)	BN07-00006A	TB	BN68-00187P	
TOSHIBA	LTM18C161	BN07-00008A	TC	BN68-00187U	
TOSHIBA	LTM15C443	BN07-00031A	TD	BN68-00195A	
TOSHIBA	LTM15C458	BN07-00043A	TE	BN68-00195H	
HANNSTAR	HSD150MX41A(A)	BN07-00020A	NA	BN68-00187Q	TTL
HANNSTAR	HSD150MX12	BN07-00030A	NB	BN68-00187Y	LVDS
TORISAN	TM150XG-22L03(A)	BN07-00021A	RA	BN68-00187R	
TORISAN	TM150XG-26L06	BN07-00042A	RB	BN68-00195J	
TORISAN	TM181SX-76N01	BN07-00048A	RC	BN68-00195Q	
TORISAN	TM150XG-22L06	BN07-00059A	RD	BN68-00239A	15" XGA TN MODE(ZPD)
TORISAN	TM290WX-71N31	BN07-00063A	RE	BN68-00239D	RS24NS (TORISAN 29" NEW PANEL)
TORISAN	TM396WX-71N31	BN07-00064A	RF	BN68-00239E	RS24NS (TORISAN 40" NEW PANEL)
SHARP	LQ181E1DG11(A)	BN07-10001C	PA	BN68-00187S	
HITACHI	TX38D12VCOCAA(A)	BN07-00003A	HA	BN68-00187T	
HITACHI	TX43DVCOCAB	BN07-00060A	HB	BN68-00239B	17" SXGA PVA MODE
IBM	ITSX94S	BN07-00017A	IA	BN68-00187V	
UNIPAC	UM170E0	BN07-00028A	UA	BN68-00187Z	
HYUNDAI	HT15X13	BN07-00035A	DA	BN68-00195F	
HYUNDAI	HT17E11-200	BN07-00049A	DB	BN68-00195R	TN MODE
ACER	L170E3	BN07-00044A	AA	BN68-00195K	TN(ADT)
CHIMEI	M170E3-L01	BN07-00050A	CA	BN68-00195S	TN PANEL
CHIMEI	M150X3-L01	BN07-00051A	CB	BN68-00195T	COMPATIBLE
CHIMEI	M170E4-L01	BN07-00052A	CC	BN68-00195U	MVA PANEL

**Copyright**

© 2002 by Samsung Electronics Co., Ltd.

All rights reserved.

This manual may not, in whole or in part, be copied, photocopied, reproduced, translated, or converted to any electronic or machine readable form without prior written permission of Samsung Electronics Co., Ltd.

MO15E\* Service Manual  
First edition March 2002.

Printed in Korea.

**Trademarks**

Samsung is a registered trademark and MO15E\* and MacMaster Cable Adapter are trademarks of Samsung Electronics Co., Ltd.

Macintosh, Centris, Quadra, Duo Dock, and Power Macintosh are trademarks of Apple Computer, Inc.

All other trademarks are the property of their respective owners.

**Memo**

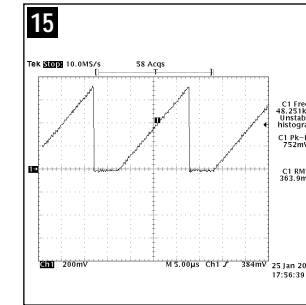
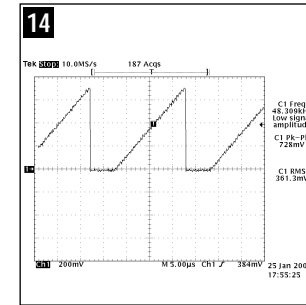
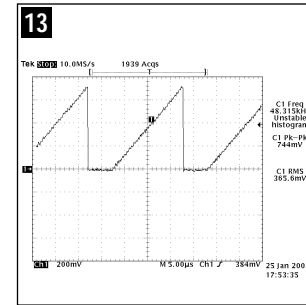
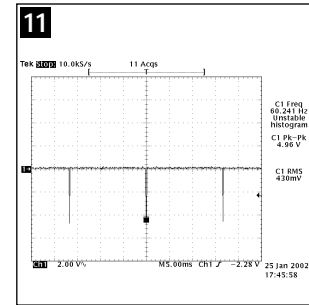
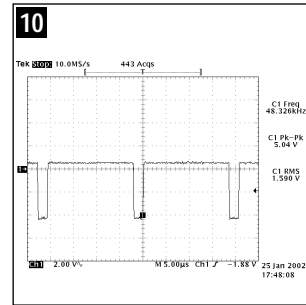
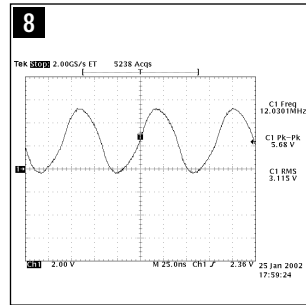

9-2 Schematic Diagram

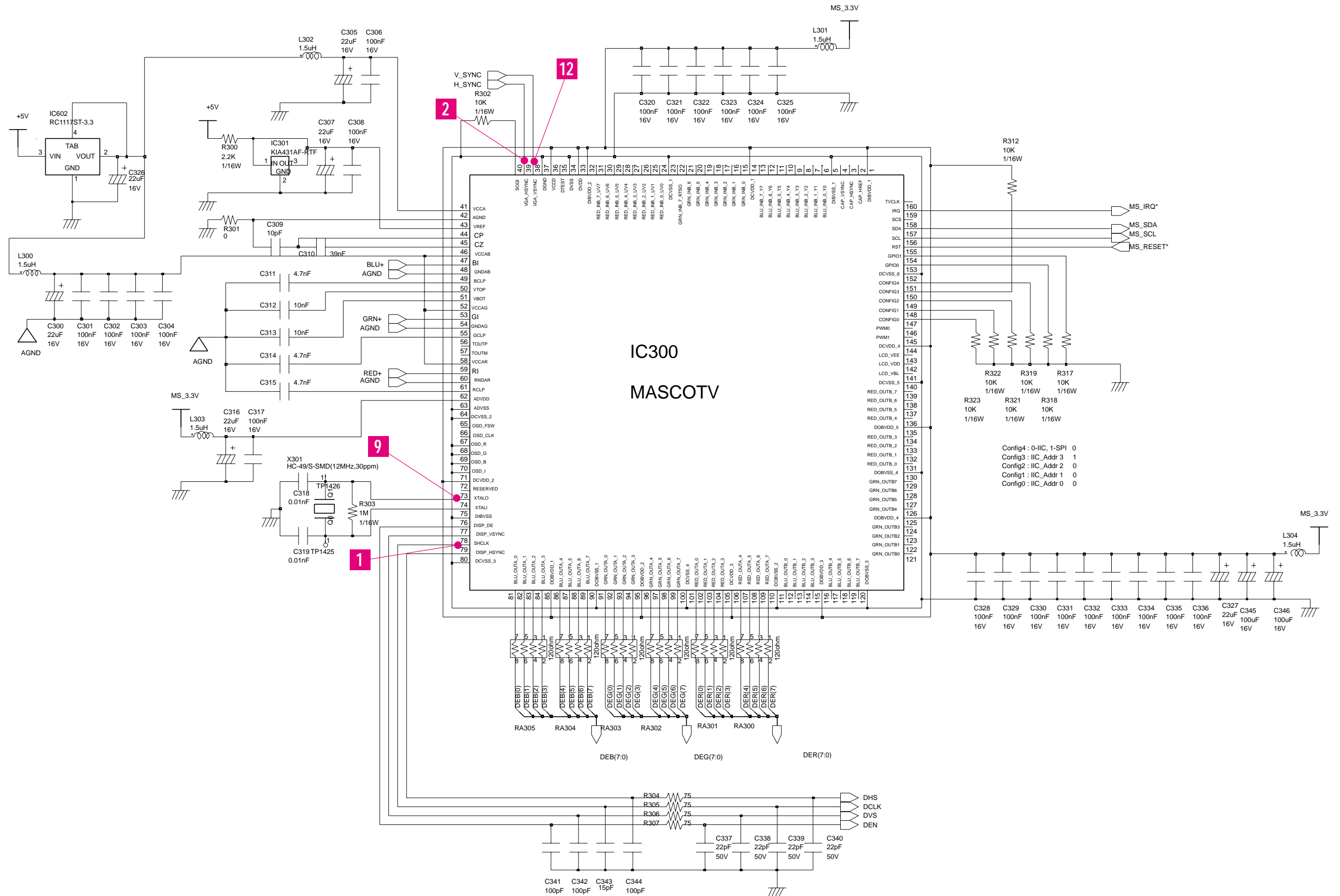

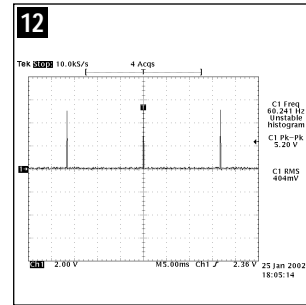
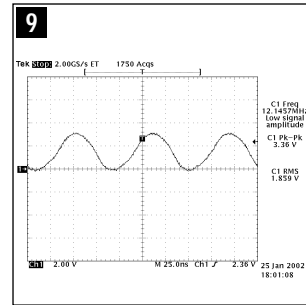
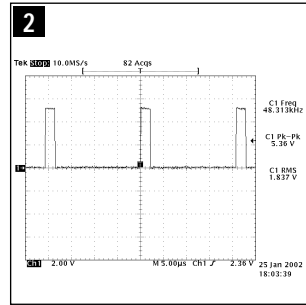
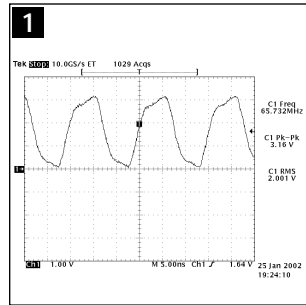



9-3 Schematic Diagram

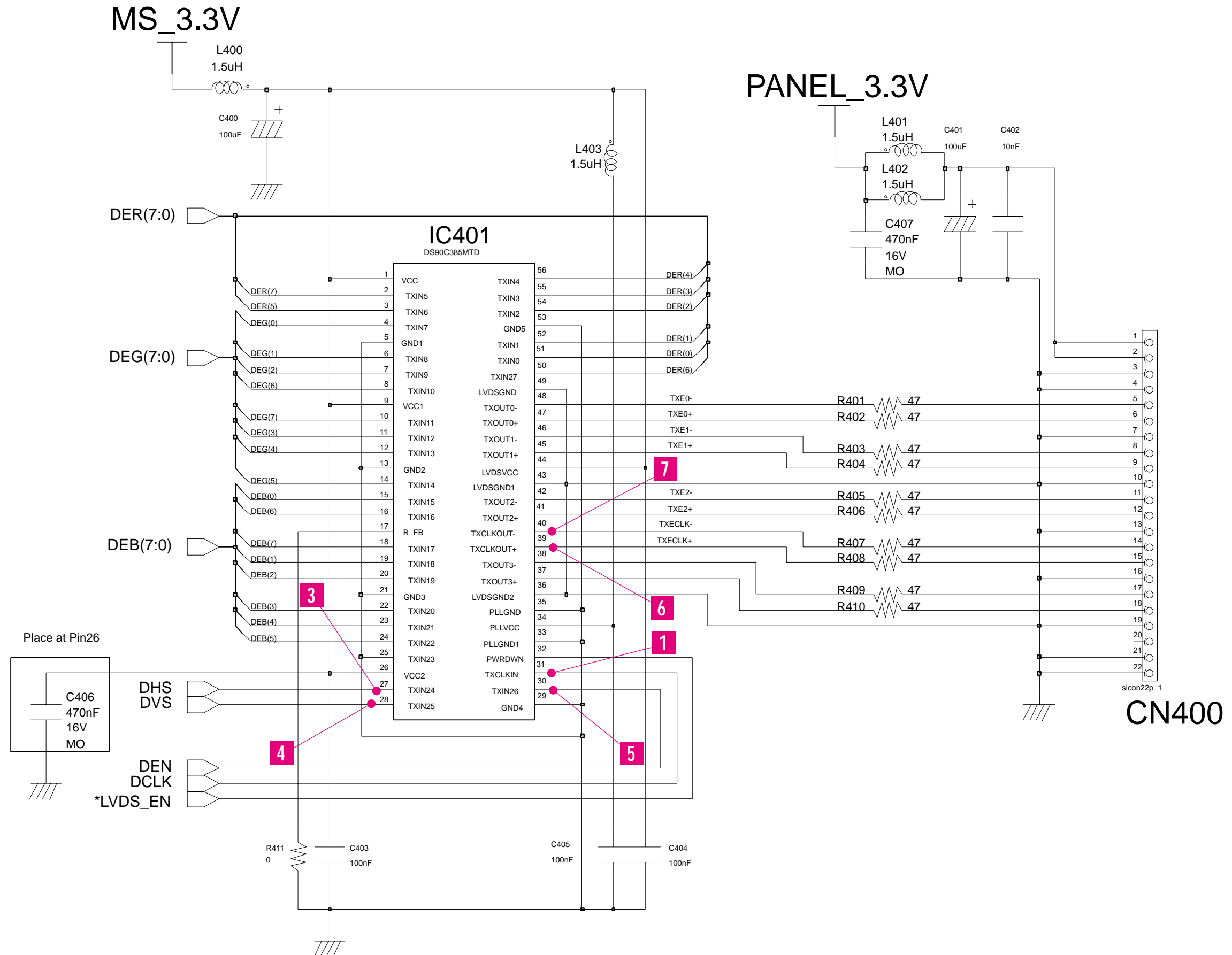

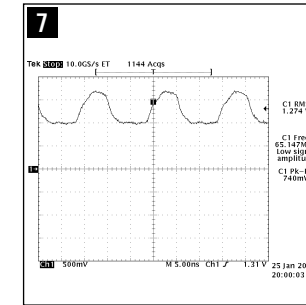
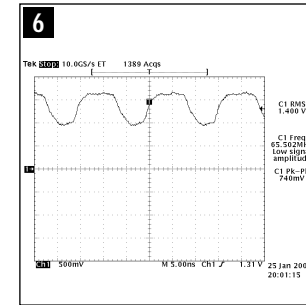
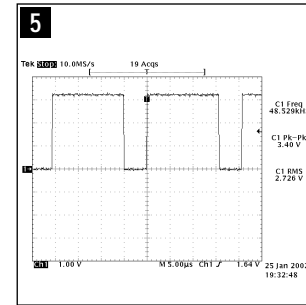
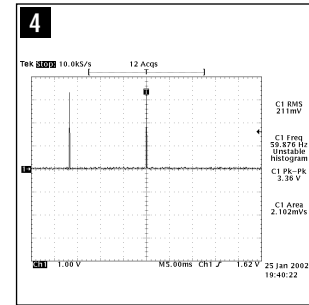
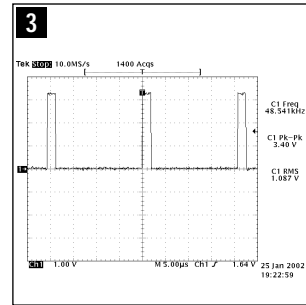
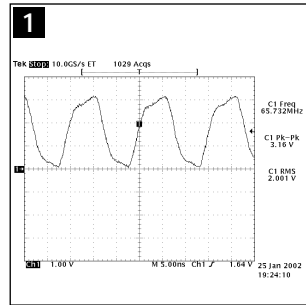

**Memo**

**Memo**

Loc. No.	Code No.	Description	Specification	Remarks
C311	2203-000888	C-CERAMIC,CHIP	4.7nF,10%,50V,X7R,TP,1608	
C312	2203-000257	C-CERAMIC,CHIP	10nF,10%,50V,X7R,TP,1608	
C313	2203-000257	C-CERAMIC,CHIP	10nF,10%,50V,X7R,TP,1608	
C314	2203-000888	C-CERAMIC,CHIP	4.7nF,10%,50V,X7R,TP,1608	
C315	2203-000888	C-CERAMIC,CHIP	4.7nF,10%,50V,X7R,TP,1608	
C316	2402-000135	C-AL,SMD	22uF,20%,16V,GP,TP,5.3x5.3x5.4	
C317	2203-005005	C-CERAMIC,CHIP	100nF,10%,16V,X7R,TP,1608	
C318	2203-000280	C-CERAMIC,CHIP	0.01nF,0.5pF,50V,NP0,TP,1608	
C319	2203-000280	C-CERAMIC,CHIP	0.01nF,0.5pF,50V,NP0,TP,1608	
C320	2203-005005	C-CERAMIC,CHIP	100nF,10%,16V,X7R,TP,1608	
C321	2203-005005	C-CERAMIC,CHIP	100nF,10%,16V,X7R,TP,1608	
C322	2203-005005	C-CERAMIC,CHIP	100nF,10%,16V,X7R,TP,1608	
C323	2203-005005	C-CERAMIC,CHIP	100nF,10%,16V,X7R,TP,1608	
C324	2203-005005	C-CERAMIC,CHIP	100nF,10%,16V,X7R,TP,1608	
C325	2203-005005	C-CERAMIC,CHIP	100nF,10%,16V,X7R,TP,1608	
C326	2402-000135	C-AL,SMD	22uF,20%,16V,GP,TP,5.3x5.3x5.4	
C327	2402-000135	C-AL,SMD	22uF,20%,16V,GP,TP,5.3x5.3x5.4	
C328	2203-005005	C-CERAMIC,CHIP	100nF,10%,16V,X7R,TP,1608	
C329	2203-005005	C-CERAMIC,CHIP	100nF,10%,16V,X7R,TP,1608	
C330	2203-005005	C-CERAMIC,CHIP	100nF,10%,16V,X7R,TP,1608	
C331	2203-005005	C-CERAMIC,CHIP	100nF,10%,16V,X7R,TP,1608	
C332	2203-005005	C-CERAMIC,CHIP	100nF,10%,16V,X7R,TP,1608	
C333	2203-005005	C-CERAMIC,CHIP	100nF,10%,16V,X7R,TP,1608	
C334	2203-005005	C-CERAMIC,CHIP	100nF,10%,16V,X7R,TP,1608	
C335	2203-005005	C-CERAMIC,CHIP	100nF,10%,16V,X7R,TP,1608	
C336	2203-005005	C-CERAMIC,CHIP	100nF,10%,16V,X7R,TP,1608	
C337	2203-000626	C-CERAMIC,CHIP	0.022nF,5%,50V,NP0,TP,1608	
C338	2203-000626	C-CERAMIC,CHIP	0.022nF,5%,50V,NP0,TP,1608	
C339	2203-000626	C-CERAMIC,CHIP	0.022nF,5%,50V,NP0,TP,1608	
C340	2203-000626	C-CERAMIC,CHIP	0.022nF,5%,50V,NP0,TP,1608	
C341	2203-000236	C-CERAMIC,CHIP	0.1nF,5%,50V,NP0,TP,1608	
C342	2203-000236	C-CERAMIC,CHIP	0.1nF,5%,50V,NP0,TP,1608	
C343	2203-000384	C-CERAMIC,CHIP	0.015nF,5%,50V,NP0,TP,1608	
C344	2203-000236	C-CERAMIC,CHIP	0.1nF,5%,50V,NP0,TP,1608	
C345	2402-001042	C-AL,SMD	100uF,20%,16V,GP,TP,6.6x6.6x5.4mm	
C346	2402-001042	C-AL,SMD	100uF,20%,16V,GP,TP,6.6x6.6x5.4mm	
C400	2402-001042	C-AL,SMD	100uF,20%,16V,GP,TP,6.6x6.6x5.4mm	
C401	2402-001042	C-AL,SMD	100uF,20%,16V,GP,TP,6.6x6.6x5.4mm	
C402	2203-000257	C-CERAMIC,CHIP	10nF,10%,50V,X7R,TP,1608	
C403	2203-005005	C-CERAMIC,CHIP	100nF,10%,16V,X7R,TP,1608	
C404	2203-005005	C-CERAMIC,CHIP	100nF,10%,16V,X7R,TP,1608	
C405	2203-005005	C-CERAMIC,CHIP	100nF,10%,16V,X7R,TP,1608	
C406	2203-001652	C-CERAMIC,CHIP	470nF,+80-20%,16V,Y5V,TP,1608	
C407	2203-001652	C-CERAMIC,CHIP	470nF,+80-20%,16V,Y5V,TP,1608	
C500	2203-005005	C-CERAMIC,CHIP	100nF,10%,16V,X7R,TP,1608	
C501	2402-001042	C-AL,SMD	100uF,20%,16V,GP,TP,6.6x6.6x5.4mm	
C502	2402-001042	C-AL,SMD	100uF,20%,16V,GP,TP,6.6x6.6x5.4mm	
C503	2203-005005	C-CERAMIC,CHIP	100nF,10%,16V,X7R,TP,1608	
C504	2402-001042	C-AL,SMD	100uF,20%,16V,GP,TP,6.6x6.6x5.4mm	
C505	2203-005005	C-CERAMIC,CHIP	100nF,10%,16V,X7R,TP,1608	
C506	2203-000626	C-CERAMIC,CHIP	0.022nF,5%,50V,NP0,TP,1608	

Loc. No.	Code No.	Description	Specification	Remarks
C507	2203-000626	C-CERAMIC,CHIP	0.022nF,5%,50V,NPO,TP,1608	
C508	2402-000108	C-AL,SMD	10uF,20%,16V,WT,TP,4.3x4.3x5.4	
C509	2203-001652	C-CERAMIC,CHIP	470nF,+80-20%,16V,Y5V,TP,1608	
C510	2203-005005	C-CERAMIC,CHIP	100nF,10%,16V,X7R,TP,1608	
C511	2203-000384	C-CERAMIC,CHIP	0.015nF,5%,50V,NPO,TP,1608	
C512	2203-000384	C-CERAMIC,CHIP	0.015nF,5%,50V,NPO,TP,1608	
C513	2203-001652	C-CERAMIC,CHIP	470nF,+80-20%,16V,Y5V,TP,1608	
C600	2203-000189	C-CERAMIC,CHIP	100nF,+80-20%,25V,Y5V,TP,1608,	
C601	2203-000189	C-CERAMIC,CHIP	100nF,+80-20%,25V,Y5V,TP,1608,	
C701	2402-001042	C-AL,SMD	100uF,20%,16V,GP,TP,6.6x6.6x5.4mm	
C702	2203-005005	C-CERAMIC,CHIP	100nF,10%,16V,X7R,TP,1608	
C703	2203-001652	C-CERAMIC,CHIP	470nF,+80-20%,16V,Y5V,TP,1608	
C704	2203-001652	C-CERAMIC,CHIP	470nF,+80-20%,16V,Y5V,TP,1608	
C705	2203-001652	C-CERAMIC,CHIP	470nF,+80-20%,16V,Y5V,TP,1608	
C706	2402-001042	C-AL,SMD	100uF,20%,16V,GP,TP,6.6x6.6x5.4mm	
CN101	3711-000556	CONNECTOR-HEADER	BOX,12P,1R,1.25mm,SMD-A,SN	SNA
CN202	3711-003161	CONNECTOR-HEADER	BOX,20P,1R,1.25mm,ANGLE,SN	SNA
CN400	3711-003161	CONNECTOR-HEADER	BOX,20P,1R,1.25mm,ANGLE,SN	SNA
CN600	3711-002049	CONNECTOR-HEADER	BOX,6P,1R,1.25mm,SMD-A,SN	SNA
D100	0402-001098	DIODE-RECTIFIER	SK34,40V,3A,SMC,TP	
D201	0403-000579	DIODE-ZENER	BZX84C5V1,5.1V,5%,200mW,SOT-23	
D202	0403-000579	DIODE-ZENER	BZX84C5V1,5.1V,5%,200mW,SOT-23	
D203	0401-001056	DIODE-SWITCHING	MMBD4148SE,75V,200MA,SOT-23,TP	
D204	0401-001056	DIODE-SWITCHING	MMBD4148SE,75V,200MA,SOT-23,TP	
D205	0401-001056	DIODE-SWITCHING	MMBD4148SE,75V,200MA,SOT-23,TP	
FT701	3301-001145	CORE-FERRITE BEAD	AB,4.5x1.6x1.6mm,-,-	SNA
IC100	1203-001447	IC-POSI.FIXED REG.	2596,TO-263,5P,-,PLASTIC,3.135	
IC200	0403-001435	DIODE-ZENER	OZX363C5V6,5.32-5.88,200MW,SOT-363,TP	
IC201	0801-002478	IC-CMOS LOGIC	7S214,SCHMITT TRIGGER,SOT23,5P,63MIL,SINGLE,TR,PLASTIC,-,-,6V,-40to+85C,200mW,-0	
IC202	1204-001551	IC-VIDEO SYSTEM	GS1881,SOIC,8P,150MIL,PLASTIC,13.2V,-,OTO+70C,TP,VIDEO SYNC SEPARATOR	
IC300	0904-001655	IC-GRAPHIC CONT.	MASCOTV,24BIT,POFF,160P,28X28MM,160MHZ,TR,CMOS,PLASTIC,3.3V,2W,OTO+70C,-,-,-,-,-	
IC301	1203-001538	IC-POSI.ADJUST REG.	431,SOT-89,3P,-,PLASTIC,2.47/3	
IC401	1205-002174	IC-TRANSMITTER	NT7181,TSSOP,56P,236MIL,PLASTIC,3.45V,-,OTO+70C,TP,NT7181	
IC500	1203-001488	IC-POSI.FIXED REG.	7805,TO-252,3P,-,PLASTIC,4.8/5	
IC501	0903-001266	IC-MICROCONTROLLER	NT68F63,8BIT,PLCC,44P,653MIL,12MHZ,ST,CMOS,PLASTIC,5V,-,OTO+70C,256B,4KB,-,-,MC	
IC502	1103-001023	IC-EEPROM	524C80D81,1028x8Bit,SOP,8P,150MIL,10mS,5V,10%,PLASTIC,0to+70C,110uA,CMOS,TP	
IC601	0403-001435	DIODE-ZENER	OZX363C5V6,5.32-5.88,200MW,SOT-363,TP	
IC602	1203-000490	IC-SWITCH VOL. REG.	1117,SOT-223,3P,-,PLASTIC,3.235/3.365V,-,0to+125C,800mA,1.224/1.264V,TP	
L101	BN27-20001A	COIL-CHOKE	-53.0UH,20%,DR10*5,-,-,-,-,0.18ohm,-,-,-,TRAY	
L201	2703-001334	INDUCTOR-SMD	1.5uH,10%,2x1.25x0.85mm	
L300	2703-001334	INDUCTOR-SMD	1.5uH,10%,2x1.25x0.85mm	
L301	2703-001334	INDUCTOR-SMD	1.5uH,10%,2x1.25x0.85mm	
L302	2703-001334	INDUCTOR-SMD	1.5uH,10%,2x1.25x0.85mm	
L303	2703-001334	INDUCTOR-SMD	1.5uH,10%,2x1.25x0.85mm	
L304	2703-001334	INDUCTOR-SMD	1.5uH,10%,2x1.25x0.85mm	
L400	2703-001334	INDUCTOR-SMD	1.5uH,10%,2x1.25x0.85mm	
L401	2703-001334	INDUCTOR-SMD	1.5uH,10%,2x1.25x0.85mm	
L402	2703-001334	INDUCTOR-SMD	1.5uH,10%,2x1.25x0.85mm	
L403	2703-001334	INDUCTOR-SMD	1.5uH,10%,2x1.25x0.85mm	
L600	2703-001334	INDUCTOR-SMD	1.5uH,10%,2x1.25x0.85mm	
L601	2703-001334	INDUCTOR-SMD	1.5uH,10%,2x1.25x0.85mm	

Loc. No.	Code No.	Description	Specification	Remarks
MP1.0	BN41-00161A	PCB MAIN	MO15ES,FR4,4L,120*100*1.0,MO15ES	
Q600	0501-000342	TR-SMALL SIGNAL	KSC1623-Y,NPN,200mW,SOT-23,TP,135-270	
Q601	0501-000342	TR-SMALL SIGNAL	KSC1623-Y,NPN,200mW,SOT-23,TP,135-270	
Q701	0501-000342	TR-SMALL SIGNAL	KSC1623-Y,NPN,200mW,SOT-23,TP,135-270	
R100	2007-000084	R-CHIP	4.7Kohm,5%,1/16W,DA,TP,1608	
R101	2007-000090	R-CHIP	10KOHM,5%,1/16W,DA,TP,1608	
R102	2007-000090	R-CHIP	10KOHM,5%,1/16W,DA,TP,1608	
R200	2007-000090	R-CHIP	10KOHM,5%,1/16W,DA,TP,1608	
R201	2007-000097	R-CHIP	47Kohm,5%,1/16W,DA,TP,1608	
R202	2007-000097	R-CHIP	47Kohm,5%,1/16W,DA,TP,1608	
R203	2007-000074	R-CHIP	100ohm,5%,1/16W,DA,TP,1608	
R204	2007-000074	R-CHIP	100ohm,5%,1/16W,DA,TP,1608	
R205	2007-000074	R-CHIP	100ohm,5%,1/16W,DA,TP,1608	
R206	2007-000074	R-CHIP	100ohm,5%,1/16W,DA,TP,1608	
R207	2007-000074	R-CHIP	100ohm,5%,1/16W,DA,TP,1608	
R208	2007-000309	R-CHIP	10ohm,5%,1/16W,DA,TP,1608	
R209	2007-000113	R-CHIP	33ohm,5%,1/16W,DA,TP,1608	
R210	2007-001167	R-CHIP	75ohm,5%,1/16W,DA,TP,1608	
R211	2007-000309	R-CHIP	10ohm,5%,1/16W,DA,TP,1608	
R212	2007-000113	R-CHIP	33ohm,5%,1/16W,DA,TP,1608	
R213	2007-001167	R-CHIP	75ohm,5%,1/16W,DA,TP,1608	
R214	2007-000309	R-CHIP	10ohm,5%,1/16W,DA,TP,1608	
R215	2007-000113	R-CHIP	33ohm,5%,1/16W,DA,TP,1608	
R216	2007-001167	R-CHIP	75ohm,5%,1/16W,DA,TP,1608	
R217	2007-000070	R-CHIP	0ohm,5%,1/16W,DA,TP,1608	
R218	2007-001114	R-CHIP	680Kohm,5%,1/16W,DA,TP,1608	
R219	2007-000309	R-CHIP	10ohm,5%,1/16W,DA,TP,1608	
R220	2007-000084	R-CHIP	4.7Kohm,5%,1/16W,DA,TP,1608	
R300	2007-000124	R-CHIP	2.2Kohm,5%,1/16W,DA,TP,1608	
R301	2007-000070	R-CHIP	0ohm,5%,1/16W,DA,TP,1608	
R302	2007-000090	R-CHIP	10KOHM,5%,1/16W,DA,TP,1608	
R303	2007-000109	R-CHIP	1Mohm,5%,1/16W,DA,TP,1608	
R304	2007-001167	R-CHIP	75ohm,5%,1/16W,DA,TP,1608	
R305	2007-001167	R-CHIP	75ohm,5%,1/16W,DA,TP,1608	
R306	2007-001167	R-CHIP	75ohm,5%,1/16W,DA,TP,1608	
R307	2007-001167	R-CHIP	75ohm,5%,1/16W,DA,TP,1608	
R312	2007-000090	R-CHIP	10KOHM,5%,1/16W,DA,TP,1608	
R317	2007-000090	R-CHIP	10KOHM,5%,1/16W,DA,TP,1608	
R318	2007-000090	R-CHIP	10KOHM,5%,1/16W,DA,TP,1608	
R319	2007-000090	R-CHIP	10KOHM,5%,1/16W,DA,TP,1608	
R321	2007-000090	R-CHIP	10KOHM,5%,1/16W,DA,TP,1608	
R322	2007-000090	R-CHIP	10KOHM,5%,1/16W,DA,TP,1608	
R323	2007-000090	R-CHIP	10KOHM,5%,1/16W,DA,TP,1608	
R401	2007-000072	R-CHIP	47ohm,5%,1/16W,DA,TP,1608	
R402	2007-000072	R-CHIP	47ohm,5%,1/16W,DA,TP,1608	
R403	2007-000072	R-CHIP	47ohm,5%,1/16W,DA,TP,1608	
R404	2007-000072	R-CHIP	47ohm,5%,1/16W,DA,TP,1608	
R405	2007-000072	R-CHIP	47ohm,5%,1/16W,DA,TP,1608	
R406	2007-000072	R-CHIP	47ohm,5%,1/16W,DA,TP,1608	
R407	2007-000072	R-CHIP	47ohm,5%,1/16W,DA,TP,1608	
R408	2007-000072	R-CHIP	47ohm,5%,1/16W,DA,TP,1608	

Loc. No.	Code No.	Description	Specification	Remarks
R409	2007-000072	R-CHIP	47ohm,5%,1/16W,DA,TP,1608	
R410	2007-000072	R-CHIP	47ohm,5%,1/16W,DA,TP,1608	
R411	2007-000070	R-CHIP	0ohm,5%,1/16W,DA,TP,1608	
R500	2007-000077	R-CHIP	470ohm,5%,1/16W,DA,TP,1608	
R501	2007-000090	R-CHIP	10KOHM,5%,1/16W,DA,TP,1608	
R502	2007-000074	R-CHIP	100ohm,5%,1/16W,DA,TP,1608	
R503	2007-000074	R-CHIP	100ohm,5%,1/16W,DA,TP,1608	
R504	2007-000090	R-CHIP	10KOHM,5%,1/16W,DA,TP,1608	
R505	2007-000109	R-CHIP	1Mohm,5%,1/16W,DA,TP,1608	
R506	2007-000074	R-CHIP	100ohm,5%,1/16W,DA,TP,1608	
R507	2007-000074	R-CHIP	100ohm,5%,1/16W,DA,TP,1608	
R508	2007-000458	R-CHIP	18Kohm,5%,1/16W,DA,TP,1608	
R509	2007-000458	R-CHIP	18Kohm,5%,1/16W,DA,TP,1608	
R511	2007-000084	R-CHIP	4.7Kohm,5%,1/16W,DA,TP,1608	
R512	2007-000084	R-CHIP	4.7Kohm,5%,1/16W,DA,TP,1608	
R513	2007-000084	R-CHIP	4.7Kohm,5%,1/16W,DA,TP,1608	
R514	2007-000070	R-CHIP	0ohm,5%,1/16W,DA,TP,1608	
R515	2007-000074	R-CHIP	100ohm,5%,1/16W,DA,TP,1608	
R516	2007-000074	R-CHIP	100ohm,5%,1/16W,DA,TP,1608	
R517	2007-000074	R-CHIP	100ohm,5%,1/16W,DA,TP,1608	
R518	2007-000078	R-CHIP	1Kohm,5%,1/16W,DA,TP,1608	
R519	2007-000084	R-CHIP	4.7Kohm,5%,1/16W,DA,TP,1608	
R520	2007-000084	R-CHIP	4.7Kohm,5%,1/16W,DA,TP,1608	
R521	2007-000074	R-CHIP	100ohm,5%,1/16W,DA,TP,1608	
R523	2007-000074	R-CHIP	100ohm,5%,1/16W,DA,TP,1608	
R524	2007-000074	R-CHIP	100ohm,5%,1/16W,DA,TP,1608	
R525	2007-000074	R-CHIP	100ohm,5%,1/16W,DA,TP,1608	
R526	2007-000074	R-CHIP	100ohm,5%,1/16W,DA,TP,1608	
R527	2007-000070	R-CHIP	0ohm,5%,1/16W,DA,TP,1608	
R604	2007-001002	R-CHIP	510ohm,5%,1/16W,DA,TP,1608	
R605	2007-001002	R-CHIP	510ohm,5%,1/16W,DA,TP,1608	
R606	2007-000074	R-CHIP	100ohm,5%,1/16W,DA,TP,1608	
R607	2007-000074	R-CHIP	100ohm,5%,1/16W,DA,TP,1608	
R700	2007-000084	R-CHIP	4.7Kohm,5%,1/16W,DA,TP,1608	
R701	2007-000309	R-CHIP	10ohm,5%,1/16W,DA,TP,1608	
R702	2007-000074	R-CHIP	100ohm,5%,1/16W,DA,TP,1608	
R703	2007-000090	R-CHIP	10KOHM,5%,1/16W,DA,TP,1608	
RA300	2011-001410	R-NETWORK	120OHM,5%,1/16W,L,CHIP,8P,TP	
RA301	2011-001410	R-NETWORK	120OHM,5%,1/16W,L,CHIP,8P,TP	
RA302	2011-001410	R-NETWORK	120OHM,5%,1/16W,L,CHIP,8P,TP	
RA303	2011-001410	R-NETWORK	120OHM,5%,1/16W,L,CHIP,8P,TP	
RA304	2011-001410	R-NETWORK	120OHM,5%,1/16W,L,CHIP,8P,TP	
RA305	2011-001410	R-NETWORK	120OHM,5%,1/16W,L,CHIP,8P,TP	
X301	2801-003773	CRYSTAL-SMD	12MHZ,30PPM,28-AAN,20PF,500HM,TP	
X501	2801-003773	CRYSTAL-SMD	12MHZ,30PPM,28-AAN,20PF,500HM,TP	



## 6-2 Others

Loc. No.	Code No.	Description	Specification	Remarks
-	BN90-00304A	ASSY COVER FRONT	M015PS	
CIS	BN90-00053B	ASSY COVER FRONT	M015PS,ABS HB,BK07,ANALOG	SNA
-	BN90-00305A	ASSY COVER REAR	M015PS	
CIS	BN90-00054B	ASSY REAR	M015ES,ABS HB BK07	
-	BN90-00306A	ASSY STAND	M015PS	
CIS	BN90-00056B	ASSY STAND	M015PS,ABS HB,BK07,ANALOG	
-	BN91-00301C	ASSY MISC-ADAPTOR	DV18MS	SNA
CIS	BN44-00058A	ADAPTOR	PSCV420106A(AD-4214N,GH17PS ,100 TO 240 VAC,47 - 63 HZ,+14VDC,3A,,42W,AC-DC,0 T	
-	BN91-00311B	ASSY LCD	GD15NS,-,-,-	SNA
CIS	BN07-00043A	LCD	LTM15C458,GH15LS,6BIT_FRC,331.6*254.7*12.5,16.1M,60,0.297*0.297,0-40,3.3,TOSHIBA	
-	BN91-00346A	ASSY CHASSIS	M015ES	
-	BN91-00350A	ASSY SHIELD	M015ES	SNA
CIS	BN90-00055A	ASSY SHIELD-PCB	M015PS,-,SECC,TO.5,-,-,-,-	SNA
-	BN92-00404A	ASSY P/MATERIAL	M015PS	SNA

**Memo**

**4-2 No Video**

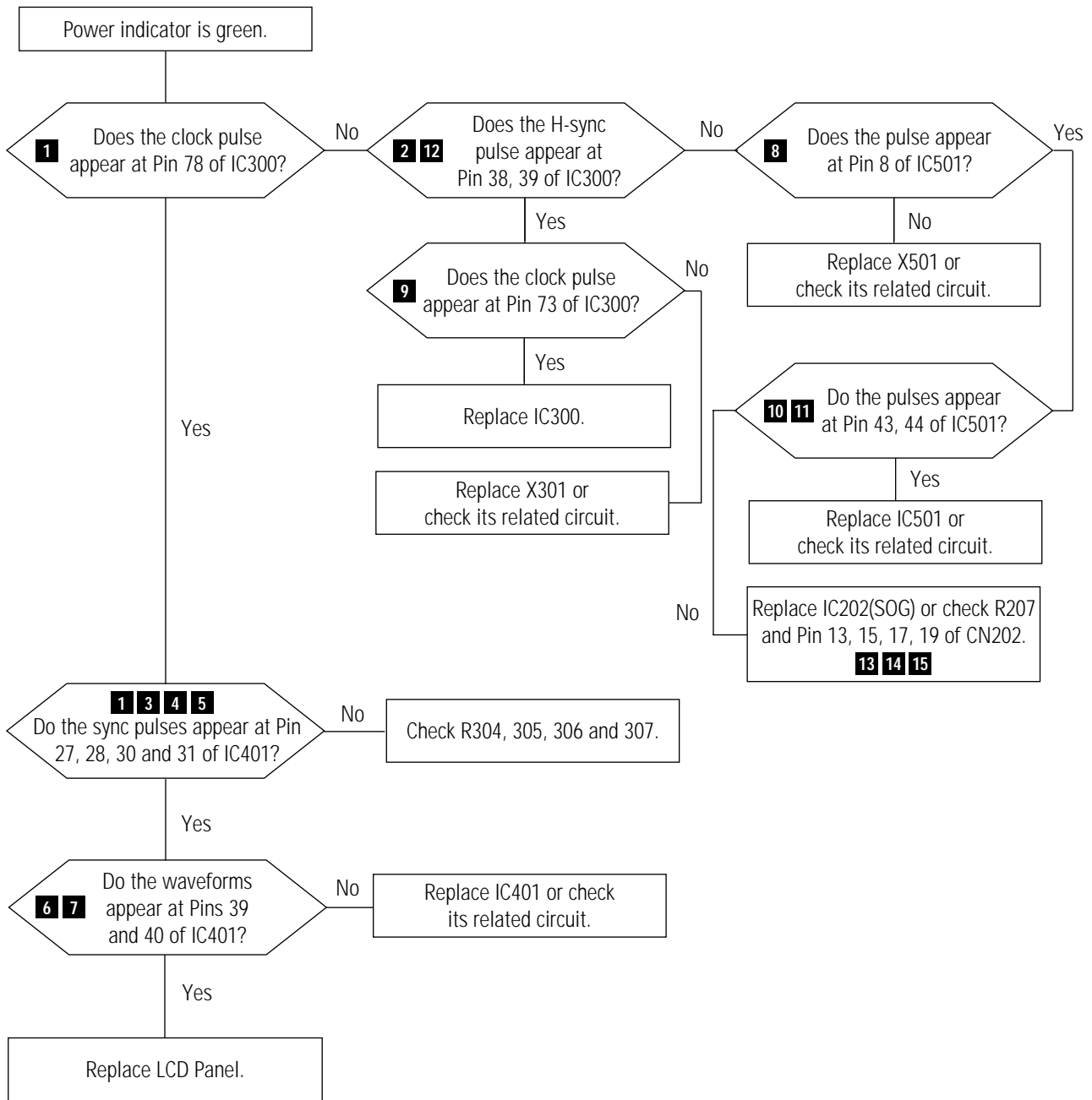

WAVEFORMS

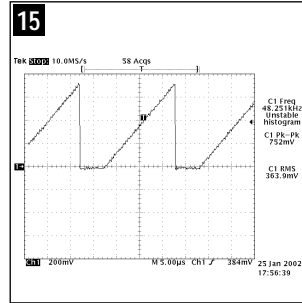
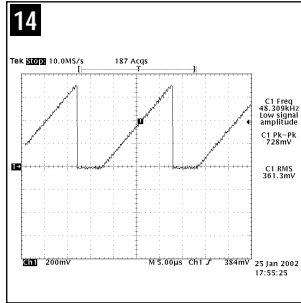
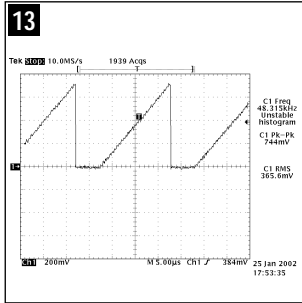
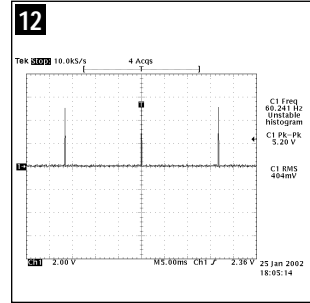
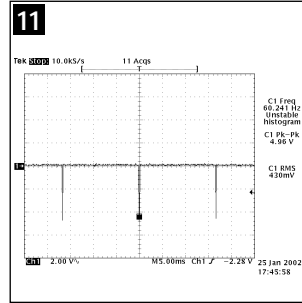
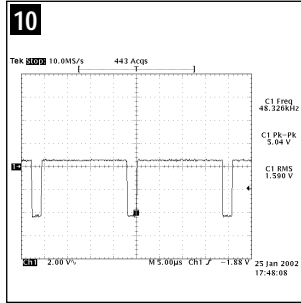
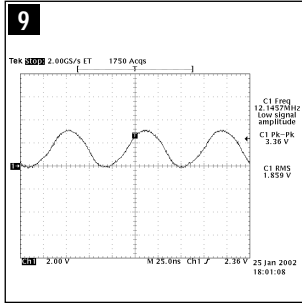
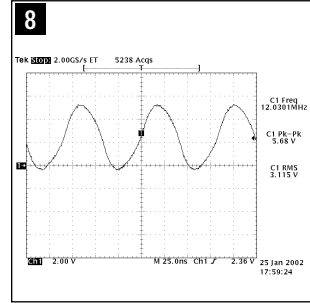
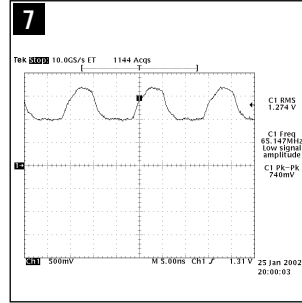
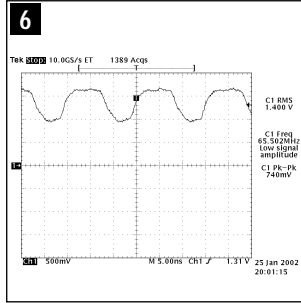
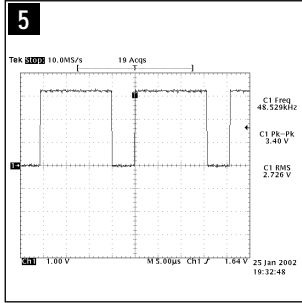
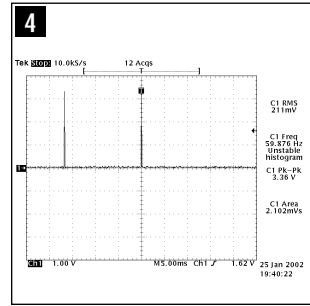
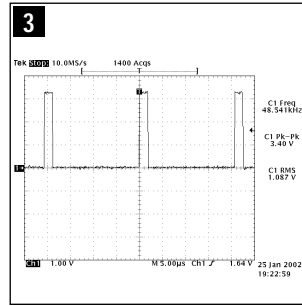
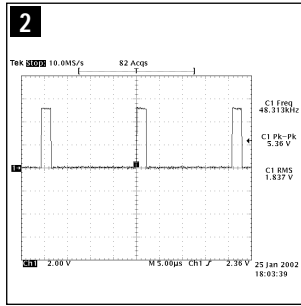
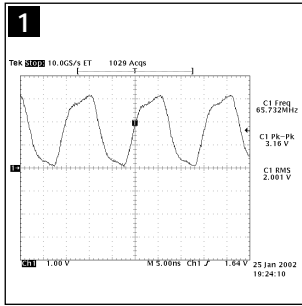

### 4-3 No OSD

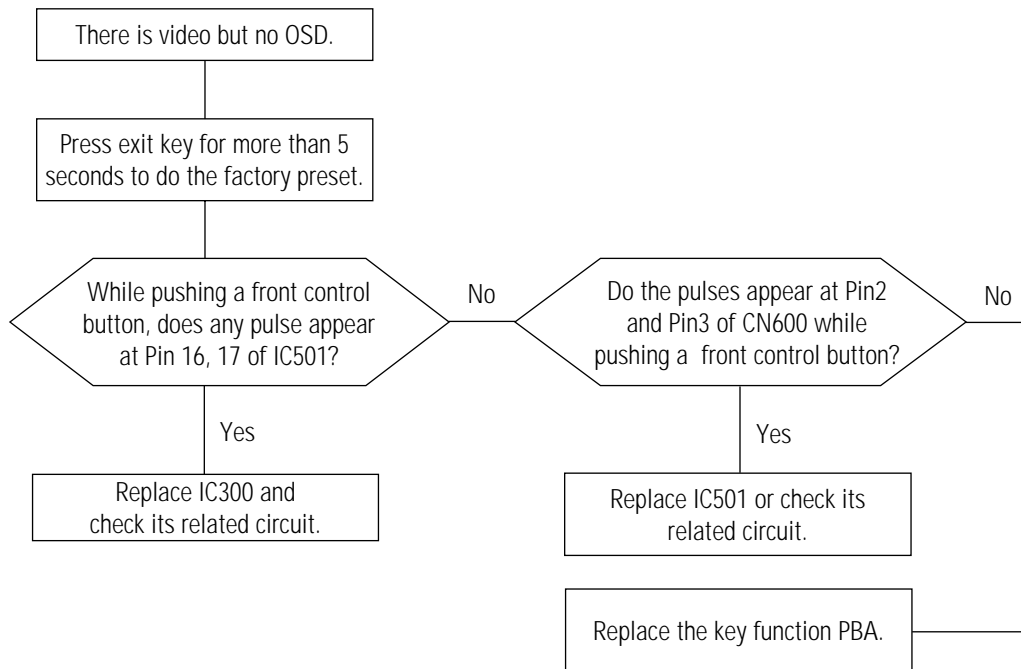



4. Remove 2 flat head screws on the hinge mounting.  
Do not remove the screw for cable clamp.



5. Disconnect the stand cable from socket and remove stand assembly.



6. Remove 2 screws of Cover Rear.

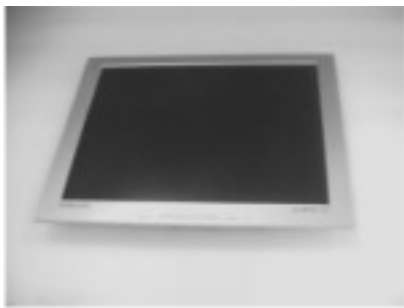

7. Turn the monitor for front-side up.

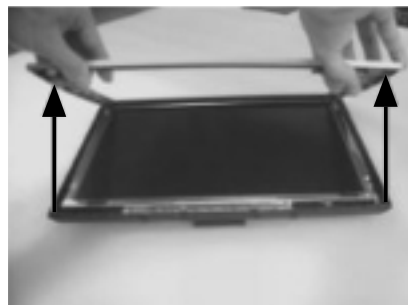
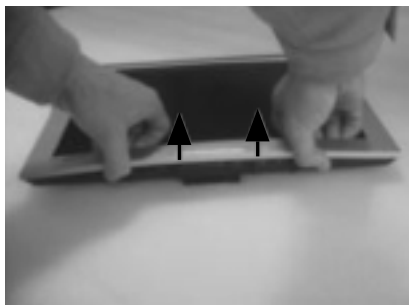

8. Remove the Cover Front by fulling the center area of bezel and side area in sequence.  
If the side area is not loosed easily, open the snap using '-' driver at the corner of slot of Cover Rear.

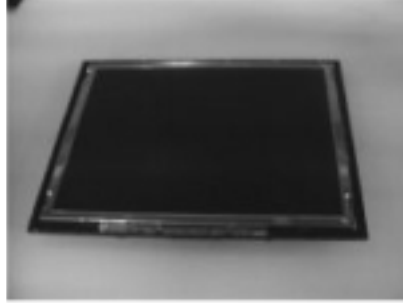
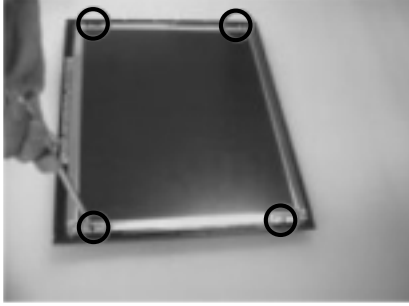

9. Remove the 4 screws of panel.

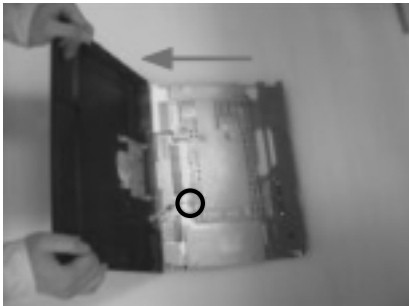

10. Turn the monitor for face down and open the Cover Rear from top area.

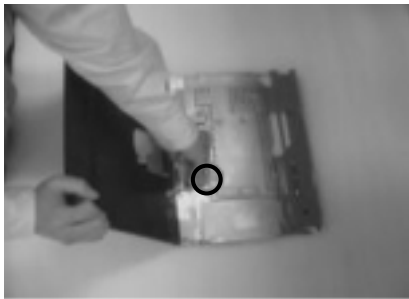

11. Disconnect the function cable from the connector of main board.



12. Remove the 3 screws of shield.

### 3-2 Replacement Order of Lamp Assemblies

---

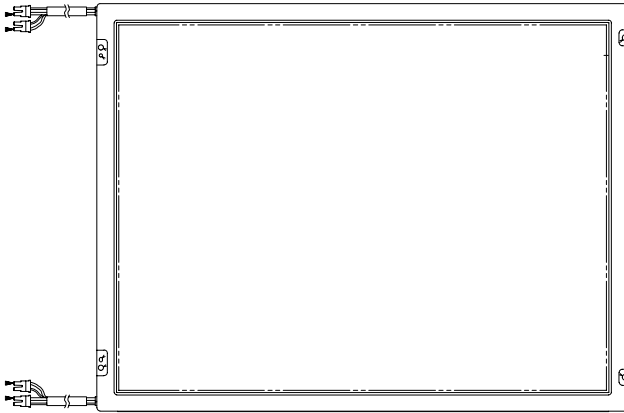

1. After confirm there is nothing on the disk  
Turn the LCD module over and put it on a flat desk set to the ground.

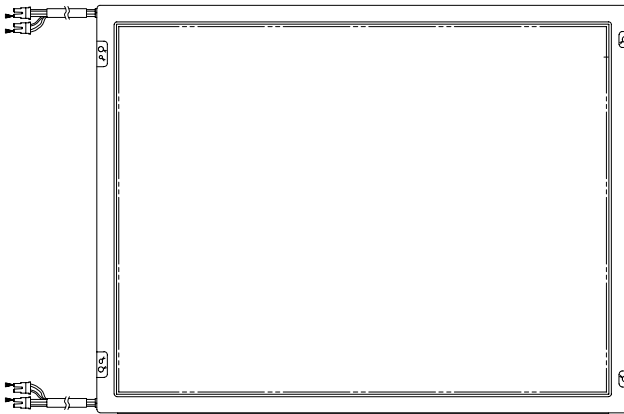

2. Remove the screw and slide the lamp unit.

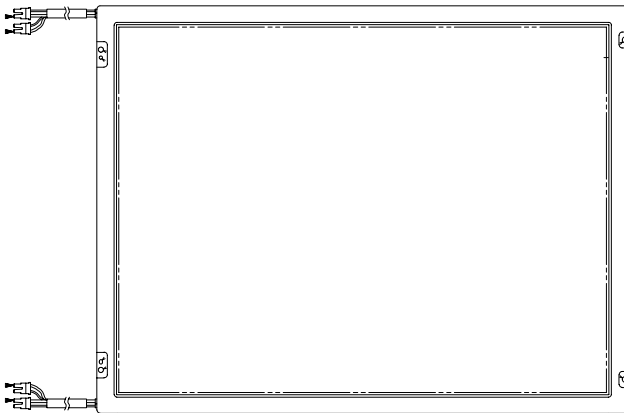

3. Please take out the lamp unit from the LCD module.



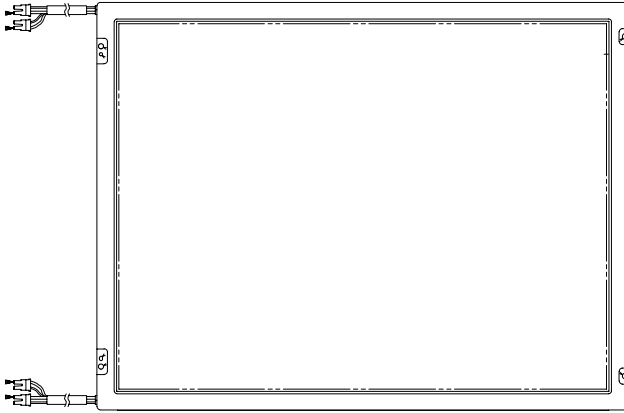

4. Please fix the new lamp units on the LCD module : opposite process 2 and 3

\* Replacement of lamp unit should be done at the power off state and recommended clean bench condition.

### **3-3 Reassembly**

---

Reassembly procedures are in the reverse order of Disassembly procedures.

**Memo**

## 2-2 Pin Assignments

Pin No.	Sync Type	15-Pin Signal Cable Connector		
		Separate	Composite	Sync-on-green
1		Red	Red	Red
2		Green	Green	Green + H/V Sync
3		Blue	Blue	Blue
4		GND	GND	GND
5		GND (DDC Return)	GND (DDC Return)	GND (DDC Return)
6		GND-R	GND-R	GND-R
7		GND-G	GND-G	GND-G
8		GND-B	GND-B	GND-B
9		No Connection	No Connection	Not Used
10		GND-Sync/Self Test	GND-Sync/Self Test	GND-Sync/Self Test
11		GND	GND	GND
12		DDC Data	DDC Data	DDC Data
13		H-Sync	H/V-Sync	Not Used
14		V-Sync	Not Used	Not Used
15		DDC Data	DDC Data	DDC Data

## 2-3 Timing Chart

This section of the service manual describes the timing that the computer industry recognizes as standard for computer-generated video signals.

Table 2-1 Timing Chart

Mode  Timing	IBM			VESA			
	VGA1/70 Hz 640 x 350	VGA2/70 Hz 720 x 400	VGA3/60 Hz 640 x 480	640/72 Hz 640 x 480	640/75 Hz 640 x 480	800/56 Hz 800 x 600	800/60 Hz 800 x 600
fH (kHz)	31.469	31.469	31.469	37.861	37.500	35.156	37.879
A $\mu$ sec	31.778	31.777	31.778	26.413	26.667	28.444	26.400
B $\mu$ sec	3.813	3.813	3.813	1.270	2.032	2.000	3.200
C $\mu$ sec	1.589	1.589	1.589	3.810	3.810	3.556	2.200
D $\mu$ sec	26.058	26.058	26.058	20.825	20.317	22.222	20.000
E $\mu$ sec	0.318	0.318	0.318	0.508	0.508	0.667	1.000
fV (Hz)	70.086	70.087	59.940	72.809	75.000	56.250	60.317
O msec	14.268	14.268	16.683	13.735	13.333	17.778	16.579
P msec	0.064	0.064	0.064	0.079	0.080	0.057	0.106
Q msec	1.716	0.858	0.794	0.528	0.427	0.626	0.607
R msec	11.504	13.155	15.761	13.100	12.800	17.067	15.840
S msec	0.985	0.191	0.064	0.026	0.027	0.028	0.026
Clock Frequency (MHz)	25.175	28.322	25.175	31.500	31.500	36.000	40.000
Polarity H.Sync	Positive	Negative	Negative	Negative	Negative	Positive	Positive
V.Sync	Negative	Positive	Negative	Negative	Negative	Negative	Positive
Remark	Separate	Separate	Separate	Separate	Separate	Separate	Separate

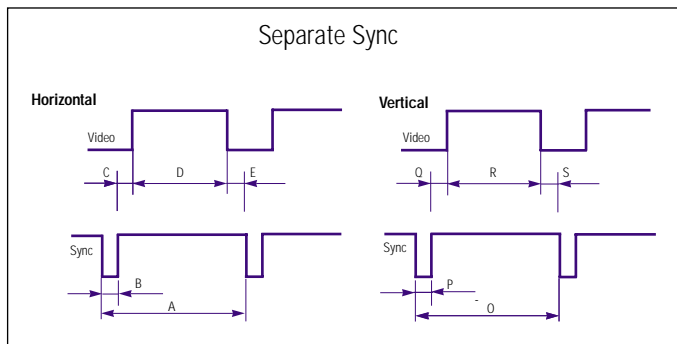

A : Line time total	B : Horizontal sync width	O : Frame time total	P : Vertical sync width
C : Back porch	D : Active time	Q : Back porch	R : Active time
E : Front porch		S : Front porch	

Table 2-1 Timing Chart Continued

Mode  Timing	VESA					MAC	
	800/72 Hz 800 x 600	800/75 Hz 800 x 600	1024/60Hz 1024x768	1024/70Hz 1024x768	1024/75Hz 1024x768	640/67 Hz 640 x 480	832/75 Hz 832 x 624
fH (kHz)	48.077	46.875	48.363	56.476	60.023	35.000	49.726
A μsec	20.800	21.333	20.677	17.707	16.660	28.571	20.110
B μsec	2.400	1.616	2.092	1.813	1.219	2.116	1.117
C μsec	1.280	3.232	2.462	1.920	2.235	3.175	3.910
D μsec	16.000	16.162	15.754	13.653	13.003	21.164	14.524
E μsec	1.120	0.323	0.369	0.320	0.203	2.116	0.559
fV (Hz)	72.188	75.000	60.004	70.069	75.029	66.667	74.551
O msec	13.853	13.333	16.666	14.272	13.328	15.000	13.414
P msec	0.125	0.064	0.124	0.106	0.050	0.086	0.060
Q msec	0.478	0.448	0.600	0.513	0.466	1.114	0.784
R msec	12.480	12.800	15.880	13.599	12.795	13.714	12.549
S msec	0.770	0.021	0.062	0.053	0.017	0.086	0.020
Clock Frequency (MHz)	50.000	49.500	65.000	75.000	78.750	30.240	57.284
Polarity H.Sync	Positive	Positive	Negative	Negative	Positive	Negative	Negative
V.Sync	Positive	Positive	Negative	Negative	Positive	Negative	Negative
Remark	Separate	Separate	Separate	Separate	Separate	Separate	Separate

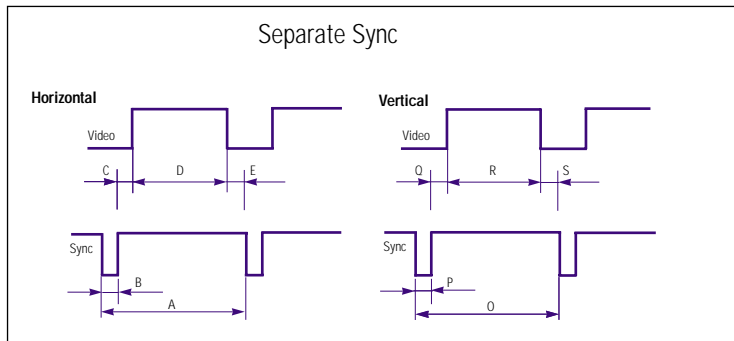

A : Line time total	B : Horizontal sync width	O : Frame time total	P : Vertical sync width
C : Back porch	D : Active time	Q : Back porch	R : Active time
E : Front porch		S : Front porch	

## 1-2 Servicing Precautions

---

**WARNING:** An electrolytic capacitor installed with the wrong polarity might explode.

**Caution:** Before servicing units covered by this service manual, read and follow the Safety Precautions section of this manual.

**Note:** If unforeseen circumstances create conflict between the following servicing precautions and any of the safety precautions, always follow the safety precautions.

### 1-2-1 General Servicing Precautions

1. Always unplug the unit's AC power cord from the AC power source and disconnect the DC Power Jack before attempting to:
  - (a) remove or reinstall any component or assembly,
  - (b) disconnect PCB plugs or connectors, (c) connect a test component in parallel with an electrolytic capacitor.
2. Some components are raised above the printed circuit board for safety. An insulation tube or tape is sometimes used. The internal wiring is sometimes clamped to prevent contact with thermally hot components. Reinstall all such elements to their original position.
3. After servicing, always check that the screws, components and wiring have been correctly reinstalled. Make sure that the area around the serviced part has not been damaged.
4. Check the insulation between the blades of the AC plug and accessible conductive parts (examples: metal panels, input terminals and earphone jacks).
5. Insulation Checking Procedure: Disconnect the power cord from the AC source and turn the power switch ON. Connect an insulation resistance meter (500 V) to the blades of the AC plug.  
The insulation resistance between each blade of the AC plug and accessible conductive parts (see above) should be greater than 1 megohm.
6. Always connect a test instrument's ground lead to the instrument chassis ground *before* connecting the positive lead; always remove the instrument's ground lead last.

## 1-3 Electrostatically Sensitive Devices (ESD) Precautions

---

Some semiconductor (solid state) devices can be easily damaged by static electricity. Such components are commonly called Electrostatically Sensitive Devices (ESD). Examples of typical ESD devices are integrated circuits and some field-effect transistors. The following techniques will reduce the incidence of component damage caused by static electricity.

1. Immediately before handling any semiconductor components or assemblies, drain the electrostatic charge from your body by touching a known earth ground. Alternatively, wear a discharging wrist-strap device. To avoid a shock hazard, be sure to remove the wrist strap before applying power to the monitor.
2. After removing an ESD-equipped assembly, place it on a conductive surface such as aluminum foil to prevent accumulation of an electrostatic charge.
3. Do not use freon-propelled chemicals. These can generate electrical charges sufficient to damage ESDs.
4. Use only a grounded-tip soldering iron to solder or desolder ESDs.
5. Use only an anti-static solder removal device. Some solder removal devices not classified as "anti-static" can generate electrical charges sufficient to damage ESDs.
6. Do not remove a replacement ESD from its protective package until you are ready to install it. Most replacement ESDs are packaged with leads that are electrically shorted together by conductive foam, aluminum foil or other conductive materials.
7. Immediately before removing the protective material from the leads of a replacement ESD, touch the protective material to the chassis or circuit assembly into which the device will be installed.  
**Caution:** Be sure no power is applied to the chassis or circuit and observe all other safety precautions.
8. Minimize body motions when handling unpackaged replacement ESDs. Motions such as brushing clothes together, or lifting your foot from a carpeted floor can generate enough static electricity to damage an ESD.



**Samsung Electronics Co.,Ltd.**

416, Maetan-3Dong, Paldal-Gu, Suwon City, Kyungki-Do, Korea.

Printed in Korea

P/N : BN81-00034C-00

<http://www.samsungmonitor.com> (SyncMaster Worldwide)

<http://www.samsung-monitor.com> (SyncMaster USA)

<http://www.sec.co.kr/monitor> (Korea)