



Spec. No.	PS-ND-0807
Rev.	A

PRODUCT SPECIFICATION

Model No : CSS-4180B7/4181B7

Descriptions:

- 0.40 Inch Single Digit Display
- Emitting Color : Super Bright Blue



CUSTOMER APPROVED	APPROVED BY	CHECKED BY	PREPARED BY
SIGNATURES			陳新強

CHINA SEMICONDUCTOR CORPORATION
Address:2FL. NO.909,Chung-Cheng Road,
Chung-Ho City Taipei Hsien,Taiwan.

Tel:886-2-2223-9696
Fax:886-2-2223-9377

OPTO PLUS TECHNOLOGIES CO.,LTD
Address:696 Shun jiang Rd.,Ji Shan St.Shaoxing,
ZheJiang,China

Tel:86-0575-8623888
Fax:86-0575-8623112



Spec. No.	PS-ND-0807
Rev.	A

Model No : CSS-4180B7/4181B7

■ Features -

1. 0.40 inch (10.16mm) digit height.
2. Case mold type.
3. RoHS compliant.
4. Low power consumption.
5. ESD>1KV(HBM)
6. Easy mounting on P.C. board or socket.

■ Device Selection Guide -

Part No.	Chip		Description
	Material	Emitted Color	
CSS-4180B7	InGaN	Super Bright Blue	Common Anode
CSS-4181B7	InGaN	Super Bright Blue	Common Cathode

■ Mechanical Dimensions -

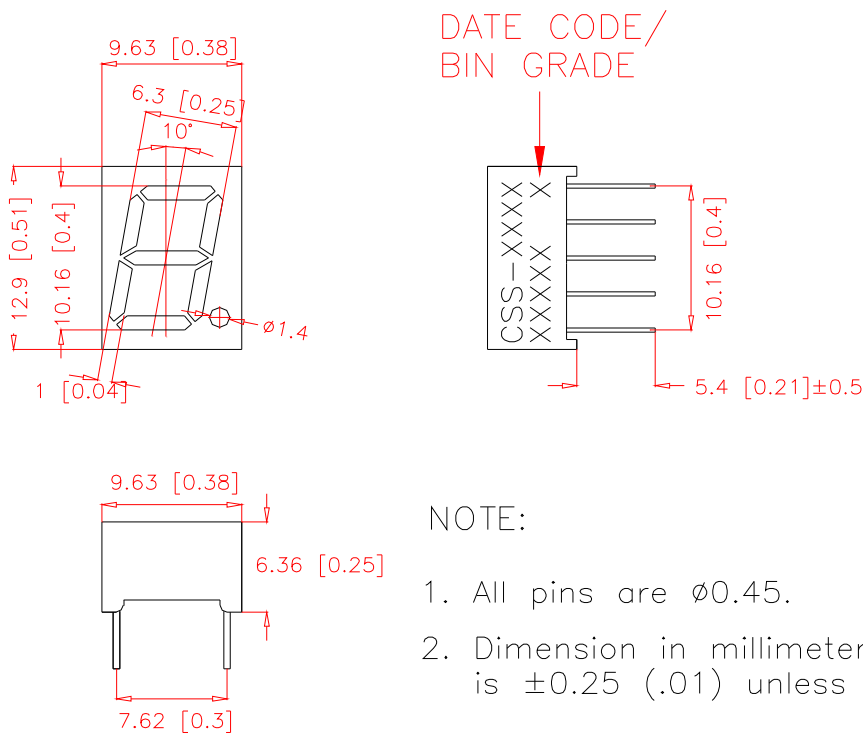

NOTE:

1. All pins are $\phi 0.45$.
2. Dimension in millimeter (inch), and tolerance is ± 0.25 (.01) unless otherwise noted.



Model No : CSS-4180B7/4181B7

Internal Circuit Diagrams -

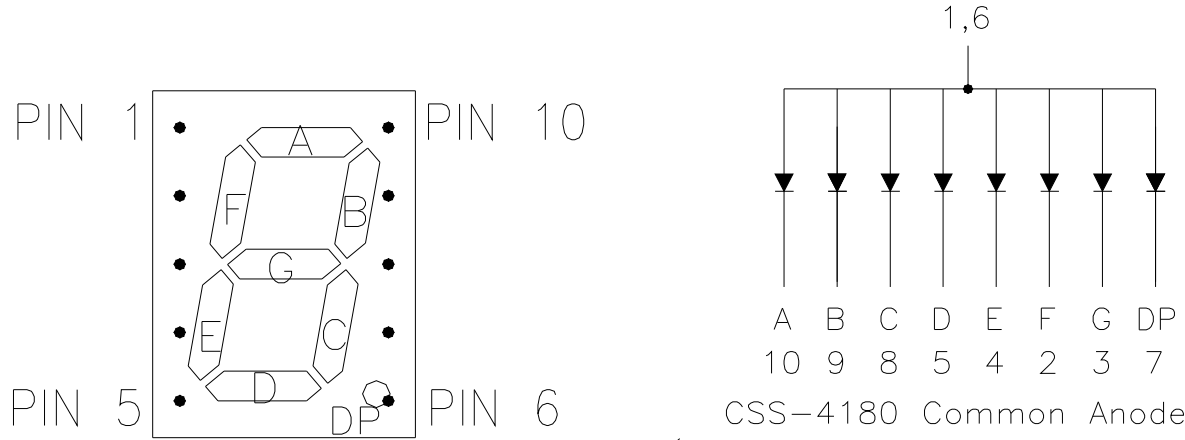

CSS-4180 Common Anode.
(CSS-4181 Common Cathode.)

Absolute Maximum Rating -

(Ta=25°C)

Parameter	Symbol	Rating	Unit
Power Dissipation Per Dice	Pd	120	mW
Continuous Forward Current Per Dice	IAF	30	mA
Peak Current Per Dice	IPF	100	mA
Derating Linear From 25°C Per Dice	-	0.4	mA/°C
Reverse Voltage Per Dice	VR	5	V
Operating Temperature	Topr	-35 ~ +85	°C
Storage Temperature	Tstg	-35 ~ +85	°C
Solder temperature 1/16 inch below seating plane for 3 seconds at 260 °C			



Model No : CSS-4180B7/4181B7

■ Electro-optical Characteristics -

(Ta=25°C)

Parameter	Symbol	Min.	Typ.	Max.	Unit	Condition
Forward Voltage Per Segment	VF	-	3.5	4	V	IF=20mA
Luminous Intensity Per Segment	Iv	6400	16000	-	ucd	IF=10mA
Peak Emission Wavelength	λP	-	468	-	nm	IF=20mA
Dominant Wavelength	λd	-	470	-	nm	IF=20mA
Spectrum Radiation Bandwidth	$\Delta \lambda$	-	20	-	nm	IF=20mA
Reverse Current	IR	-	-	100	μA	VR=5V
Luminous Intensity Matching Ratio	IV-m	-	-	2:1	-	IF=10mA



Model No : CSS-4180B7/4181B7

■ Typical Electrical / Optical Characteristics Curves -

(Ta = 25°C Unless Otherwise Noted)

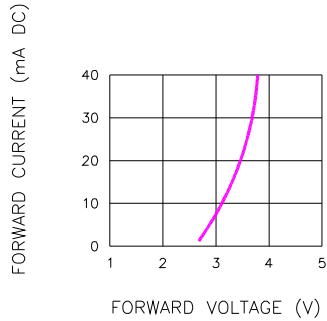

Fig.1 FORWARD CURRENT VS. FORWARD VOLTAGE

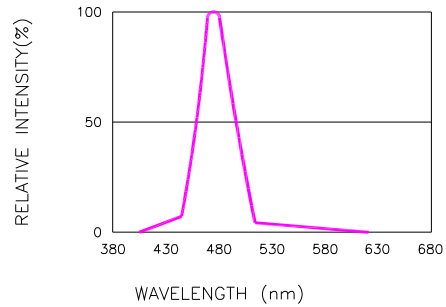

Fig.2 RELATIVE INTENSITY VS. WAVELENGTH

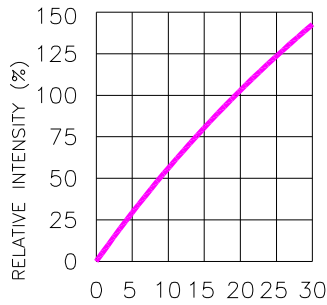

Fig.3 RELATIVE INTENSITY VS. FORWARD CURRENT

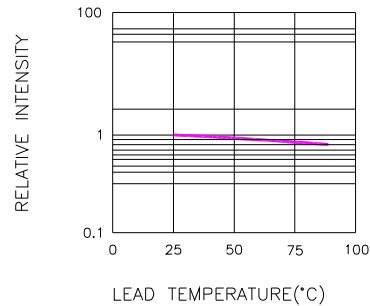

Fig.4 RELATIVE INTENSITY VS. LEAD TEMPERATURE
(PULSED 20 mA; 300us PULSE, 10ms PERIOD)

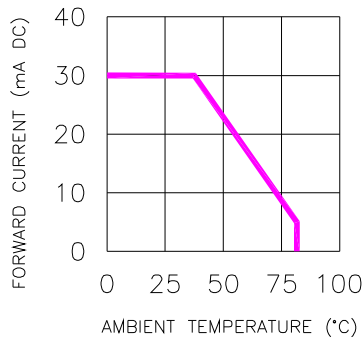

Fig.5 FORWARD CURRENT VS. AMBIENT TEMPERATURE

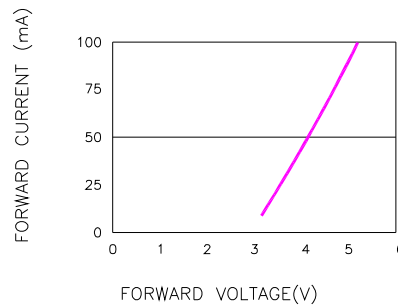

Fig.6 PEAK FORWARD VOLTAGE VS. FORWARD(100us TEST PULSE, 1% DUTY CYCLE)



Spec. No.	PS-ND-0807
Rev.	A

Model No : CSS-4180B7/4181B7

■ Package Dimensions

Single Digit Display
Dice Code
CSS-41XX

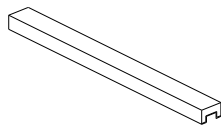

38 Pcs Per Tube

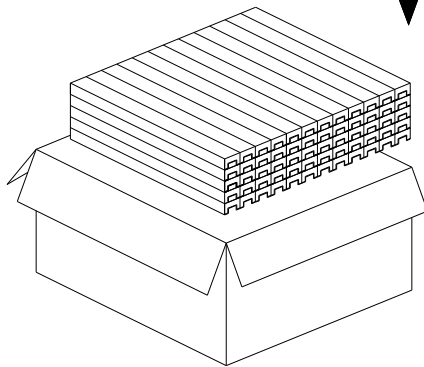

90 Tubes Per Inner Box
Total Q'TY: 3420 Pcs

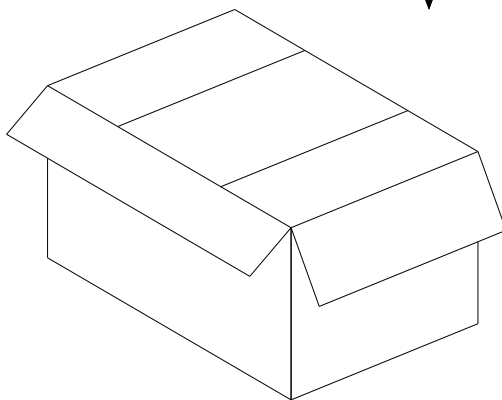

3 Inner Boxes Per Carton.
Total Q'TY: 10260 Pcs
Carton Size:
L540*W485*H305.5 mm

Note: The specifications are subject to change without notice. Please contact us for updated information.