

**HPC16164/26164/36164/46164**  
**HPC16104/26104/36104/46104**  
**HPC16064/26064/36064/46064**  
**HPC16004/26004/36004/46004**  
**High-Performance microControllers with A/D**

**General Description**

The HPC16164, HPC16104, HPC16064 and HPC16004 are members of the HPC™ family of High Performance micro-Controllers. Each member of the family has the same core CPU with a unique memory and I/O configuration to suit specific applications. The HPC16164 and HPC16104 have 16k bytes of on-chip ROM. The HPC16104 and HPC16104 have no on-chip ROM and is intended for use with external memory. Each part is fabricated in National's advanced microCMOS technology. This process combined with an advanced architecture provides fast, flexible I/O control, efficient data manipulation, and high speed computation.

The HPC devices are complete microcomputers on a single chip. All system timing, internal logic, ROM, RAM, and I/O are provided on the chip to produce a cost effective solution for high performance applications. On-chip functions such as UART, up to eight 16-bit timers with 4 input capture registers, vectored interrupts, WATCHDOG logic and MICROWIRE/PLUS™ provide a high level of system integration. The ability to address up to 64k bytes of external memory enables the HPC to be used in powerful applications typically performed by microprocessors and expensive peripheral chips. The term "HPC16164" is used throughout this data-sheet to refer to the HPC16164, HPC16104, HPC16064 and HPC16004 devices unless otherwise specified.

The HPC16164 and HPC16104 have, as an on-board peripheral, an 8-channel 8-bit Analog-to-Digital Converter. This A/D converter can operate in single-ended mode where the analog input voltage is applied across one of the eight input channels (D0-D7) and AGND. The A/D converter can also

operate in differential mode where the analog input voltage is applied across two adjacent input channels. The A/D converter will convert up to eight channels in single-ended mode and up to four channel pairs in differential mode. The HPC16064 and HPC16004 do not have onboard A/D.

The microCMOS process results in very low current drain and enables the user to select the optimum speed/power product for his system. The IDLE and HALT modes provide further current savings. The HPC is available in 68-pin PLCC, LCC, LDCC, PGA and 84-pin TapePak® packages.

**Features**

- HPC family—core features:
  - 16-bit architecture, both byte and word
  - 16-bit data bus, ALU, and registers
  - 64k bytes of external direct memory addressing
  - FAST—200 ns for fastest instruction when using 20.0 MHz clock
  - High code efficiency—most instructions are single byte
  - 16 x 16 multiply and 32 x 16 divide
  - Eight vectored interrupt sources
  - Four 16-bit timer/counters with 4 synchronous outputs and WATCHDOG logic
  - MICROWIRE/PLUS serial I/O interface
  - CMOS—very low power with two power save modes: IDLE and HALT
- A/D—8-channel 8-bit analog-to-digital converter with conversion time minimum 6.6 μs for single conversion
- A/D—supports conversions in "quiet mode"

**Block Diagram (HPC16164 with 16k ROM shown)**

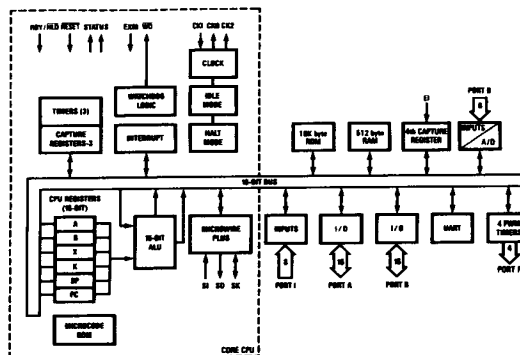

TL/DD/9682-1

Series 32000®, TapePak®, and TRI-STATE® are registered trademarks of National Semiconductor Corporation. MOLE™, HPC™, COP™ microcontrollers and MICROWIRE/PLUS™ are trademarks of National Semiconductor Corporation.

**HPC16164/26164/36164/46164, 16104/26104/36104/46104, 16064/26064/36064/46064, HPC16004/26004/36004/46004 High-Performance microControllers with A/D**

## Features (Continued)

- UART—full duplex, programmable baud rate
- Four additional 16-bit timer/counters with pulse width modulated outputs
- Four input capture registers
- 52 general purpose I/O lines (memory mapped)

- 16k bytes of ROM, 512 bytes of RAM on-chip
- ROMless version available (HPC16104)
- Commercial (0°C to +70°C), industrial (-40°C to +85°C), automotive (-40°C to +105°C) and military (-55°C to +125°C) temperature ranges

## Absolute Maximum Ratings

If Military/Aerospace specified devices are required, please contact the National Semiconductor Sales Office/Distributors for availability and specifications.

Total Allowable Source or Sink Current	100 mA
Storage Temperature Range	-65°C to +150°C
Lead Temperature (Soldering, 10 sec.)	300°C

V <sub>CC</sub> with Respect to GND	-0.5V to 7.0V
All Other Pins	(V <sub>CC</sub> + 0.5)V to (GND - 0.5)V
ESD Rating	2000V

Note: Absolute maximum ratings indicate limits beyond which damage to the device may occur. DC and AC electrical specifications are not ensured when operating the device at absolute maximum ratings.

## 20 MHz

**DC Electrical Characteristics** V<sub>CC</sub> = 5.0V ±10% unless otherwise specified, T<sub>A</sub> = 0°C to +70°C for HPC46164/HPC46104, HPC46064/HPC46004, -40°C to +85°C for HPC36164/HPC36104, HPC36064/HPC36004, -40°C to +105°C for HPC26164/HPC26104, HPC26064/HPC26004, -55°C to +125°C for HPC16164/HPC16104, HPC16064/HPC16004

Symbol	Parameter	Test Conditions	Min	Max	Units
I <sub>CC1</sub>	Supply Current	V <sub>CC</sub> = 5.5V, f <sub>in</sub> = 20.0 MHz (Note 1)		40	mA
		V <sub>CC</sub> = 5.5V, f <sub>in</sub> = 2.0 MHz (Note 1)		15	mA
I <sub>CC2</sub>	IDLE Mode Current	V <sub>CC</sub> = 5.5V, f <sub>in</sub> = 20.0 MHz, (Note 1)		3.5	mA
		V <sub>CC</sub> = 5.5V, f <sub>in</sub> = 2.0 MHz, (Note 1)		1	mA
I <sub>CC3</sub>	HALT Mode Current	V <sub>CC</sub> = 5.5V, f <sub>in</sub> = 0 kHz, (Note 1)		300	μA
		V <sub>CC</sub> = 2.5V, f <sub>in</sub> = 0 kHz, (Note 1)		100	μA

### INPUT VOLTAGE LEVELS RESET, NMI, CKI AND WO (SCHMITT TRIGGERED)

V <sub>IH1</sub>	Logic High		0.9 V <sub>CC</sub>		V
V <sub>IL1</sub>	Logic Low			0.1 V <sub>CC</sub>	V

### ALL OTHER INPUTS

V <sub>IH2</sub>	Logic High		0.7 V <sub>CC</sub>		V
V <sub>IL2</sub>	Logic Low			0.2 V <sub>CC</sub>	V
I <sub>L1</sub>	Input Leakage Current			±1	μA
I <sub>L2</sub>	Input Leakage Current RDY/HLD, EXU1		-3	-50	μA
I <sub>L3</sub>	Input Leakage Current B12		0.5	7	μA
C <sub>I</sub>	Input Capacitance	(Note 2)		10	pF
C <sub>I/O</sub>	I/O Capacitance	(Note 2)		20	pF

### OUTPUT VOLTAGE LEVELS

V <sub>OH1</sub>	Logic High (CMOS)	I <sub>OH</sub> = -10 μA (Note 2)	V <sub>CC</sub> - 0.1		V
V <sub>OL1</sub>	Logic Low (CMOS)	I <sub>OH</sub> = 10 μA (Note 2)		0.1	V
V <sub>OH2</sub>	Port A/B Drive, CK2 (A <sub>0</sub> -A <sub>15</sub> , B <sub>10</sub> , B <sub>11</sub> , B <sub>12</sub> , B <sub>15</sub> )	I <sub>OH</sub> = -7 mA	2.4		V
		I <sub>OL</sub> = 3 mA		0.4	V
V <sub>OH3</sub>	Other Port Pin Drive, WO (open drain) (B <sub>0</sub> -B <sub>9</sub> , B <sub>13</sub> , B <sub>14</sub> , P <sub>0</sub> -P <sub>3</sub> )	I <sub>OH</sub> = -1.6 mA	2.4		V
		I <sub>OL</sub> = 0.5 mA		0.4	V
V <sub>OH4</sub>	ST1 and ST2 Drive	I <sub>OH</sub> = -6 mA	2.4		V
		I <sub>OL</sub> = 1.6 mA		0.4	V
V <sub>RAM</sub>	RAM Keep-Alive Voltage	(Note 3)	2.5	V <sub>CC</sub>	V
I <sub>OZ</sub>	TRI-STATE® Leakage Current			±5	μA

Note 1: I<sub>CC1</sub>, I<sub>CC2</sub>, I<sub>CC3</sub> measured with no external drive (I<sub>OH</sub> and I<sub>OL</sub> = 0, I<sub>IH</sub> and I<sub>IL</sub> = 0). I<sub>CC1</sub> is measured with RESET = GND. I<sub>CC3</sub> is measured with NMI = V<sub>CC</sub> and A/D inactive. CKI driven to V<sub>IH1</sub> and V<sub>IL1</sub> with rise and fall times less than 10 ns. V<sub>REF</sub> = AGND = GND.

Note 2: This is guaranteed by design and not tested.

Note 3: Test duration is 100 ms.

## 20 MHz

**AC Electrical Characteristics**  $V_{CC} = 5.0V \pm 10\%$  unless otherwise specified,  $T_A = 0^\circ C$  to  $+70^\circ C$  for HPC46164/HPC46104, HPC46064/HPC46004,  $-40^\circ C$  to  $+85^\circ C$  for HPC36164/HPC36104, HPC36064/HPC36004,  $-40^\circ C$  to  $+105^\circ C$  for HPC26164/HPC26104, HPC26064/HPC26004,  $-55^\circ C$  to  $+125^\circ C$  for HPC16164/HPC16104, HPC16064/HPC16004

Symbol	Parameter	Min	Max	Units
$f_C = \text{CKI freq.}$	Operating Frequency	2	20	MHz
$t_{C1} = 1/f_C$	Clock Period	50	500	ns
$t_{CKIR}$ (Note 3)	CKI Rise Time		7	ns
$t_{CKIF}$ (Note 3)	CKI Fall Time		7	ns
$[(t_{CKIH}/(t_{CKIH} + t_{CKIL}))]100$	Duty Cycle	45	55	%
$t_C = 2/f_C$	Timing Cycle	100		ns
$t_{LL} = \frac{1}{2} t_C - 9$	ALE Pulse Width	41		ns
$t_{DC1C2R}$ (Notes 1, 2)	Delay from CKI Falling Edge to CK2 Rising Edge	0	55	ns
$t_{DC1C2F}$ (Notes 1, 2)	Delay from CKI Falling Edge to CK2 Falling Edge	0	55	ns
$t_{DC1ALER}$ (Notes 1, 2)	Delay from CKI Rising Edge to ALE Rising Edge	0	35	ns
$t_{DC1ALEF}$ (Notes 1, 2)	Delay from CKI Rising Edge to ALE Falling Edge	0	35	ns
$t_{DC2ALER} = \frac{1}{4} t_C + 20$ (Note 2)	Delay from CK2 Rising Edge to ALE Rising Edge		45	ns
$t_{DC2ALEF} = \frac{1}{4} t_C + 20$ (Note 2)	Delay from CK2 Falling Edge to ALE Falling Edge		45	ns
$t_{ST} = \frac{1}{4} t_C - 7$	Address Valid to ALE Falling Edge	18		ns
$t_{VP} = \frac{1}{4} t_C - 5$	Address Hold from ALE Falling Edge	20		ns
$t_{WAIT} = t_C$	Wait State Period	100		ns
$f_{XIN} = f_C/19$	External Timer Input Frequency		1.052	MHz
$t_{XIN} = t_C$	Pulse Width for Timer Inputs	100		ns
$f_{XOUT} = f_C/16$	Timer Output Frequency		1.25	MHz
$f_{MW} = f_C/19$	External MICROWIRE/PLUS Clock Input Frequency		1.052	MHz
$f_U = f_C/8$	External UART Clock Input Frequency		2.5	MHz

### CKI Input Signal Characteristics

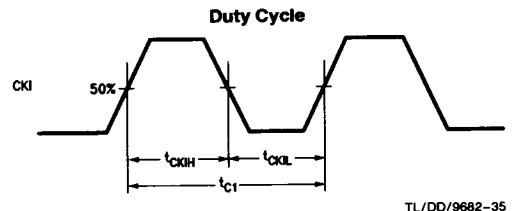
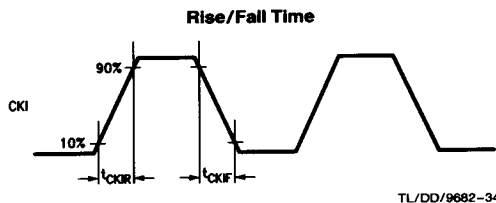

## 20 MHz

### Read Cycle Timing

Symbol	Parameter	Min	Max	Units
$t_{ARR} = \frac{1}{4} t_C - 5$	ALE Falling Edge to $\overline{RD}$ Falling Edge	20		ns
$t_{RW} = \frac{1}{2} t_C + WS - 10$	$\overline{RD}$ Pulse Width	140		ns
$t_{DR} = \frac{3}{4} t_C - 15$	Data Hold after Rising Edge of $\overline{RD}$	0	60	ns
$t_{ACC} = t_C + WS - 55$ (Note 2)	Address Valid to Input Data Valid		145	ns
$t_{RD} = \frac{1}{2} t_C + WS - 65$	$\overline{RD}$ Falling Edge to Input Data Valid		85	ns
$t_{RDA} = t_C - 5$	$\overline{RD}$ Rising Edge to Address Valid	95		ns

### Write Cycle Timing

Symbol	Parameter	Min	Max	Units
$t_{ARW} = \frac{1}{2} t_C - 5$	ALE Falling Edge to $\overline{WR}$ Falling Edge	45		ns
$t_{WW} = \frac{3}{4} t_C + WS - 15$	$\overline{WR}$ Pulse Width	160		ns
$t_{HW} = \frac{1}{4} t_C - 5$	Data Hold after Rising Edge of $\overline{WR}$	20		ns
$t_V = \frac{1}{2} t_C + WS - 5$	Data Valid before Rising Edge of $\overline{WR}$	145		ns

**Note:** Bus Output (Port A)  $C_L = 100$  pF, CK2 Output  $C_L = 50$  pF, other Outputs  $C_L = 80$  pF. AC parameters are tested using DC Characteristics Inputs and non CMOS Outputs. Measurement of AC Specifications is done with external clock driving CK1 with 50% duty cycle. The capacitive load on CKO must be kept below 15 pF or AC measurement will be skewed.

**Note:**  $WS = t_{WAIT} \times$  number of pre-programmed wait states. Minimum and maximum values are calculated from maximum operating frequency with one (1) wait state pre-programmed.

**Note 1:** Do not design with this parameter unless CK1 is driven with an active signal. When using a passive crystal circuit, CK1 or CKO *should not* be connected to any external logic since any load (besides the passive components in the crystal circuit) will affect the stability of the crystal unpredictably.

**Note 2:** These are not directly tested parameters. Therefore the given min/max value cannot be guaranteed. It is, however, derived from measured parameters, and may be used for system design with a very high confidence level.

**Note 3:** This is guaranteed by design and not tested.

### Ready/Hold Timing

Symbol	Parameter	Min	Max	Units
$t_{DAR} = \frac{1}{4} t_C + WS - 50$	Falling Edge of ALE to Falling Edge of RDY		75	ns
$t_{RWP} = t_C$	RDY Pulse Width	100		ns
$t_{SALE} = \frac{3}{4} t_C + 40$	Falling Edge of HLD to Rising Edge of ALE	115		ns
$t_{HWP} = t_C + 10$	$\overline{HLD}$ Pulse Width	110		ns
$t_{HAD} = \frac{3}{4} t_C + 85$	Rising Edge on $\overline{HLD}$ to Rising Edge on HLDA		160	ns
$t_{HAE} = t_C + 100$	Falling Edge on HLD to Falling Edge on HLDA		200*	ns
$t_{BF} = \frac{1}{2} t_C + 66$	Data Valid after Falling Edge on HLDA		116†	ns
$t_{BE} = \frac{1}{2} t_C + 66$	Bus Enable from Rising Edge of HLDA	116†		ns

\***Note:**  $t_{HAE}$  may be as long as  $(3t_C + 4ws + 72t_C + 90)$  depending on which instruction is being executed, the addressing mode and number of wait states.

$t_{HAE}$  maximum value is for the optimal case.

†**Note:** Due to emulation restrictions—actual limits will be better.

## 20 MHz

### MICROWIRE/PLUS Timing

Symbol	Parameter	Min	Max	Units
$t_{UWS}$ Master Slave	MICROWIRE Setup Time	100 20		ns
$t_{UWH}$ Master Slave	MICROWIRE Hold Time	20 50		ns
$t_{UWV}$ Master Slave	MICROWIRE Output Valid Time		50 150	ns

### UPI Read/Write Timing

Symbol	Parameter	Min	Max	Units
$t_{UAS}$	Address Setup Time to Falling Edge of $\overline{URD}$	10		ns
$t_{UAH}$	Address Hold Time from Rising Edge of $\overline{URD}$	10		ns
$t_{RPW}$	$\overline{URD}$ Pulse Width	100		ns
$t_{OE}$	$\overline{URD}$ Falling Edge to Output Data Valid	0	60	ns
$t_{OD}$	Rising Edge of $\overline{URD}$ to Output Data Invalid (Note 4)	5	35	ns
$t_{DRDY}$	$\overline{RDRDY}$ Delay from Rising Edge of $\overline{URD}$		70	ns
$t_{WDW}$	$\overline{UWR}$ Pulse Width	40		ns
$t_{UDS}$	Input Data Valid before Rising Edge of $\overline{UWR}$	10		ns
$t_{UDH}$	Input Data Hold after Rising Edge of $\overline{UWR}$	15		ns
$t_A$	$\overline{WRRDY}$ Delay from Rising Edge of $\overline{UWR}$		70	ns

Note: Bus Output (Port A)  $C_L = 100$  pF, CK2 Output  $C_L = 50$  F, other Outputs  $C_L = 80$  pF.

Note 4: Guaranteed by design.

#### Input and Output for AC Tests



TL/DD/9682-40

Note: AC testing inputs are driven at  $V_{IH}$  for a logic "1" and  $V_{IL}$  for a logic "0". Output timing measurements are made at  $V_{OH}$  for a logic "1" and  $V_{OL}$  for a logic "0".

## 20 MHz

**A/D Converter Specifications**  $V_{CC} = 5V \pm 10\%$  unless otherwise specified,  $T_A = 0^\circ\text{C}$  to  $+70^\circ\text{C}$  for HPC46164/HPC46104,  $-40^\circ\text{C}$  to  $+85^\circ\text{C}$  for HPC36164/HPC36104,  $-40^\circ\text{C}$  to  $+105^\circ\text{C}$  for HPC26164/HPC26104,  $-55^\circ\text{C}$  to  $+125^\circ\text{C}$  for HPC16164/HPC16104

Symbol	Parameter	Min	Max	Units
	Resolution		8	bits
$f_{CCLK}$	Clock Frequency (Note 4)	0.1	1.6	MHz
$t_{CON} = 8.5/f_{CCLK}$	Conversion Time (Note 3)	5.3		$\mu\text{s}$
$V_{REF}$	Reference Voltage Input (AGND = 0V)	3.0	$V_{CC}$	V
	Total Unadjusted Error (Note 1) ( $V_{REF} = 5.000\text{V}$ )		$\pm 1/2$	LSB
$R_{VREF}$	Reference Input Resistance (Note 5)	1.6	4.8	$\text{k}\Omega$
	DC Common Mode Error		$\pm 1/4$	LSB
	Power Supply Sensitivity ( $V_{REF} = 5.000\text{V}$ , $V_{CC} = 5V \pm 10\%$ )		$\pm 1/4$	LSB
	Voltage Reference Tolerance ( $V_{REF}$ )		TBD	LSB
	Port D Input Capacitance (Note 5)		35	$\text{pF}$
	Analog Input Voltage Range (Note 2)	$\text{GND} - 0.05$	$V_{CC} + 0.05$	V
	On Channel Leakage		1	$\mu\text{A}$
	Off Channel Leakage		1	$\mu\text{A}$

**Note 1:** Total unadjusted error includes offset, full-scale, and multiplexer errors.

**Note 2:** 8 single-ended or 4 differential channels. Inherent sample and hold for single-ended inputs (GND = Pin 62).

**Note 3:** Conversion time does not include sample/hold time plus overhead. Sample and hold time is  $2/f_{CCLK}$ . Overhead is  $1/f_{CCLK}$ .

**Note 4:** Clock supplied to A/D converter is derived from CKI. See A/D description for details.

**Note 5:** This is guaranteed by design and not tested.

## 30 MHz

### Absolute Maximum Ratings

If Military/Aerospace specified devices are required, please contact the National Semiconductor Sales Office/Distributors for availability and specifications.

Total Allowable Source or Sink Current	100 mA
Storage Temperature Range	-65°C to +150°C
Lead Temperature (Soldering, 10 sec.)	300°C

V <sub>CC</sub> with Respect to GND	-0.5V to 7.0V
All Other Pins	(V <sub>CC</sub> + 0.5)V to (GND - 0.5)V
ESD Rating	2000V

Note: Absolute maximum ratings indicate limits beyond which damage to the device may occur. DC and AC electrical specifications are not ensured when operating the device at absolute maximum ratings.

## 20 MHz

**DC Electrical Characteristics** V<sub>CC</sub> = 5.0V ±10% unless otherwise specified, T<sub>A</sub> = 0°C to +70°C for HPC46164/HPC46104, HPC46064/HPC46004, -40°C to +85°C for HPC36164/HPC36104, HPC36064/HPC36004, -40°C to +105°C for HPC26164/HPC26104, HPC26064/HPC26004, -55°C to +125°C for HPC16164/HPC16104, HPC16064/HPC16004

Symbol	Parameter	Test Conditions	Min	Max	Units
I <sub>CC1</sub>	Supply Current	V <sub>CC</sub> = 5.5V, f <sub>in</sub> = 30.0 MHz (Note 1)		TBD	mA
		V <sub>CC</sub> = 5.5V, f <sub>in</sub> = 2.0 MHz (Note 1)		15	mA
I <sub>CC2</sub>	IDLE Mode Current	V <sub>CC</sub> = 5.5V, f <sub>in</sub> = 30.0 MHz, (Note 1)		TBD	mA
		V <sub>CC</sub> = 5.5V, f <sub>in</sub> = 2.0 MHz, (Note 1)		2	mA
I <sub>CC3</sub>	HALT Mode Current	V <sub>CC</sub> = 5.5V, f <sub>in</sub> = 0 kHz, (Note 1)		400	μA
		V <sub>CC</sub> = 2.5V, f <sub>in</sub> = 0 kHz, (Note 1)		250	μA

### INPUT VOLTAGE LEVELS RESET, NMI, CKI AND WO (SCHMITT TRIGGERED)

Symbol	Parameter	Test Conditions	Min	Max	Units
V <sub>IH1</sub>	Logic High		0.9 V <sub>CC</sub>		V
V <sub>IL1</sub>	Logic Low			0.1 V <sub>CC</sub>	V

### ALL OTHER INPUTS

Symbol	Parameter	Test Conditions	Min	Max	Units
V <sub>IH2</sub>	Logic High		0.7 V <sub>CC</sub>		V
V <sub>IL2</sub>	Logic Low			0.2 V <sub>CC</sub>	V
I <sub>L1</sub>	Input Leakage Current			±1	μA
I <sub>L2</sub>	Input Leakage Current RDY/HLD, EXU1		-3	-50	μA
I <sub>L3</sub>	Input Leakage Current B12		0.5	7	μA
C <sub>I</sub>	Input Capacitance	(Note 2)		10	pF
C <sub>IO</sub>	I/O Capacitance	(Note 2)		20	pF

### OUTPUT VOLTAGE LEVELS

Symbol	Parameter	Test Conditions	Min	Max	Units
V <sub>OH1</sub>	Logic High (CMOS)	I <sub>OH</sub> = -10 μA (Note 2)	V <sub>CC</sub> - 0.1		V
V <sub>OL1</sub>	Logic Low (CMOS)	I <sub>OH</sub> = 10 μA (Note 2)		0.1	V
V <sub>OH2</sub>	Port A/B Drive, CK2 (A <sub>0</sub> -A <sub>15</sub> , B <sub>10</sub> , B <sub>11</sub> , B <sub>12</sub> , B <sub>15</sub> )	I <sub>OH</sub> = -7 mA	2.4		V
		I <sub>OL</sub> = 3 mA		0.4	V
V <sub>OH3</sub>	Other Port Pin Drive, WO (open drain) (B <sub>0</sub> -B <sub>9</sub> , B <sub>13</sub> , B <sub>14</sub> , P <sub>0</sub> -P <sub>3</sub> )	I <sub>OH</sub> = -1.6 mA	2.4		V
		I <sub>OL</sub> = 0.5 mA		0.4	V
V <sub>OH4</sub>	ST1 and ST2 Drive	I <sub>OH</sub> = -6 mA	2.4		V
		I <sub>OL</sub> = 1.6 mA		0.4	V
V <sub>RAM</sub>	RAM Keep-Alive Voltage	(Note 3)	2.5	V <sub>CC</sub>	V
I <sub>OZ</sub>	TRI-STATE® Leakage Current			±5	μA

Note 1: I<sub>CC1</sub>, I<sub>CC2</sub>, I<sub>CC3</sub> measured with no external drive (I<sub>OH</sub> and I<sub>OL</sub> = 0, I<sub>IH</sub> and I<sub>IL</sub> = 0). I<sub>CC1</sub> is measured with RESET = GND. I<sub>CC3</sub> is measured with NMI = V<sub>CC</sub> and A/D inactive. CKI driven to V<sub>IH1</sub> and V<sub>IL1</sub> with rise and fall times less than 10 ns. V<sub>REF</sub> = AGND = GND.

Note 2: This is guaranteed by design and not tested.

Note 3: Test duration is 100 ns.

## 30 MHz

**AC Electrical Characteristics**  $V_{CC} = 5.0V \pm 10\%$  unless otherwise specified,  $T_A = 0^\circ C$  to  $+70^\circ C$  for HPC46164/HPC46104, HPC46064/HPC46004,  $-40^\circ C$  to  $+85^\circ C$  for HPC36164/HPC36104, HPC36064/HPC36004,  $-40^\circ C$  to  $+105^\circ C$  for HPC26164/HPC26104, HPC26064/HPC26004,  $-55^\circ C$  to  $+125^\circ C$  for HPC16164/HPC16104, HPC16064/HPC16004

Symbol	Parameter	Min	Max	Units
$f_C = \text{CKI freq.}$	Operating Frequency	2	30	MHz
$t_{C1} = 1/f_C$	Clock Period	33	500	ns
$t_{CKIR}$ (Note 3)	CKI Rise Time		7	ns
$t_{CKIF}$ (Note 3)	CKI Fall Time		7	ns
$[t_{CKIH}/(t_{CKIH} + t_{CKIL})]100$	Duty Cycle	45	55	%
$t_C = 2/f_C$	Timing Cycle	66		ns
$t_{LL} = \frac{1}{2} t_C - 9$	ALE Pulse Width	24		ns
$t_{DC1C2R}$ (Notes 1, 2)	Delay from CKI Falling Edge to CK2 Rising Edge	0	55	ns
$t_{DC1C2F}$ (Notes 1, 2)	Delay from CKI Falling Edge to CK2 Falling Edge	0	55	ns
$t_{DC1ALER}$ (Notes 1, 2)	Delay from CKI Rising Edge to ALE Rising Edge	0	35	ns
$t_{DC1ALEF}$ (Notes 1, 2)	Delay from CKI Rising Edge to ALE Falling Edge	0	35	ns
$t_{DC2ALER} = \frac{1}{4} t_C + 20$ (Note 2)	Delay from CK2 Rising Edge to ALE Rising Edge		37	ns
$t_{DC2ALEF} = \frac{1}{4} t_C + 20$ (Note 2)	Delay from CK2 Falling Edge to ALE Falling Edge		37	ns
$t_{ST} = \frac{1}{4} t_C - 7$	Address Valid to ALE Falling Edge	9		ns
$t_{VP} = \frac{1}{4} t_C - 5$	Address Hold from ALE Falling Edge	11		ns
$t_{WAIT} = t_C$	Wait State Period	66		ns
$f_{XIN} = f_C/19$	External Timer Input Frequency		1.579	MHz
$t_{XIN} = t_C$	Pulse Width for Timer Inputs	66		ns
$f_{XOUT} = f_C/16$	Timer Output Frequency		1.875	MHz
$f_{MW} = f_C/19$	External MICROWIRE/PLUS Clock Input Frequency		1.579	MHz
$f_U = f_C/8$	External UART Clock Input Frequency		3.75	MHz

## CKI Input Signal Characteristics

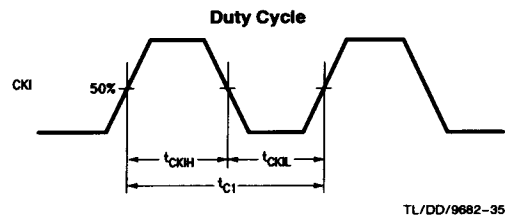
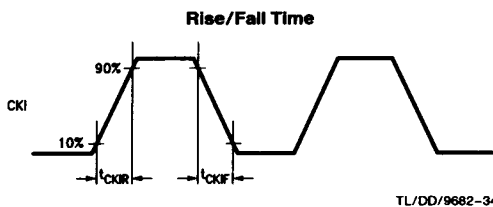



## 30 MHz

### Read Cycle Timing

Symbol	Parameter	Min	Max	Units
$t_{ARR} = \frac{1}{4} t_C - 5$	ALE Falling Edge to $\overline{RD}$ Falling Edge	12		ns
$t_{RW} = \frac{1}{2} t_C + WS - 14$	$\overline{RD}$ Pulse Width	85		ns
$t_{DR} = \frac{3}{4} t_C - 15$	Data Hold after Rising Edge of $\overline{RD}$	0	35	ns
$t_{ACC} = t_C + WS - 32$ (Note 2)	Address Valid to Input Data Valid		100	ns
$t_{RD} = \frac{1}{2} t_C + WS - 39$	$\overline{RD}$ Falling Edge to Input Data Valid		60	ns
$t_{RDA} = t_C - 5$	$\overline{RD}$ Rising Edge to Address Valid	61		ns

### Write Cycle Timing

Symbol	Parameter	Min	Max	Units
$t_{ARW} = \frac{1}{2} t_C - 5$	ALE Falling Edge to $\overline{WR}$ Falling Edge	28		ns
$t_{WW} = \frac{3}{4} t_C + WS - 15$	$\overline{WR}$ Pulse Width	101		ns
$t_{HW} = \frac{1}{4} t_C - 10$	Data Hold after Rising Edge of $\overline{WR}$	7		ns
$t_V = \frac{1}{2} t_C + WS - 5$	Data Valid before Rising Edge of $\overline{WR}$	94		ns

**Note:** Bus Output (Port A)  $C_L = 100$  pF, CK2 Output  $C_L = 50$  pF, other Outputs  $C_L = 80$  pF. AC parameters are tested using DC Characteristics Inputs and non CMOS Outputs. Measurement of AC Specifications is done with external clock driving CK1 with 50% duty cycle. The capacitive load on CK0 must be kept below 15 pF or AC measurement will be skewed.

**Note:**  $WS = t_{WAIT} \times$  number of pre-programmed wait states. Minimum and maximum values are calculated from maximum operating frequency with one (1) wait state pre-programmed.

**Note 1:** Do not design with this parameter unless CK1 is driven with an active signal. When using a passive crystal circuit, CK1 or CK0 *should not* be connected to any external logic since any load (besides the passive components in the crystal circuit) will affect the stability of the crystal unpredictably.

**Note 2:** These are not directly tested parameters. Therefore the given min/max value cannot be guaranteed. It is, however, derived from measured parameters, and may be used for system design with a very high confidence level.

**Note 3:** This is guaranteed by design and not tested.

### Ready/Hold Timing

Symbol	Parameter	Min	Max	Units
$t_{DAR} = \frac{1}{4} t_C + WS - 50$	Falling Edge of ALE to Falling Edge of RDY		75	ns
$t_{RWP} = t_C$	RDY Pulse Width	100		ns
$t_{SALE} = \frac{3}{4} t_C + 40$	Falling Edge of $\overline{HLD}$ to Rising Edge of ALE	115		ns
$t_{HWP} = t_C + 10$	$\overline{HLD}$ Pulse Width	110		ns
$t_{HAD} = \frac{3}{4} t_C + 85$	Rising Edge on $\overline{HLD}$ to Rising Edge on $\overline{HLDA}$		160	ns
$t_{HAE} = t_C + 85$	Falling Edge on $\overline{HLD}$ to Falling Edge on $\overline{HLDA}$		151*	ns
$t_{BF}$	Data Valid after Falling Edge on $\overline{HLDA}$	0		ns
$t_{BE} = \frac{1}{2} t_C$	Bus Enable from Rising Edge of $\overline{HLDA}$	33		ns

\***Note:**  $t_{HAE}$  may be as long as  $(3t_C + 4ws + 72t_C + 90)$  depending on which instruction is being executed, the addressing mode and number of wait states.  $t_{HAE}$  maximum value is for the optimal case.

# 30 MHz

## MICROWIRE/PLUS Timing

Symbol	Parameter	Min	Max	Units
$t_{UWS}$ Master Slave	MICROWIRE Setup Time	100 20		ns
$t_{UWH}$ Master Slave	MICROWIRE Hold Time	20 50		ns
$t_{UWV}$ Master Slave	MICROWIRE Output Valid Time		50 150	ns

## UPI Read/Write Timing

Symbol	Parameter	Min	Max	Units
$t_{UAS}$	Address Setup Time to Falling Edge of $\overline{URD}$	10		ns
$t_{UAH}$	Address Hold Time from Rising Edge of $\overline{URD}$	10		ns
$t_{RPW}$	$\overline{URD}$ Pulse Width	100		ns
$t_{OE}$	$\overline{URD}$ Falling Edge to Output Data Valid	0	60	ns
$t_{OD}$	Rising Edge of $\overline{URD}$ to Output Data Invalid (Note 4)	5	35	ns
$t_{DRDY}$	$\overline{RDRDY}$ Delay from Rising Edge of $\overline{URD}$		70	ns
$t_{WDW}$	$\overline{UWR}$ Pulse Width	40		ns
$t_{UDS}$	Input Data Valid before Rising Edge of $\overline{UWR}$	10		ns
$t_{UDH}$	Input Data Hold after Rising Edge of $\overline{UWR}$	15		ns
$t_A$	$\overline{WRRDY}$ Delay from Rising Edge of $\overline{UWR}$		70	ns

Note: Bus Output (Port A)  $C_L = 100$  pF, CK2 Output  $C_L = 50$  F, other Outputs  $C_L = 80$  pF.

Note: AC testing inputs are driven at  $V_{IH}$  for a logic "1" and  $V_{OL}$  for a logic "0". Output timing measurements are made at  $V_{OH}$  for a logic "1" and  $V_{OL}$  for a logic "0".

Note 4: Guaranteed by design.

### Input and Output for AC Tests



TL/DD/9682-40

## 30 MHz

**A/D Converter Specifications**  $V_{CC} = 5V \pm 10\%$  unless otherwise specified,  $T_A = 0^\circ\text{C}$  to  $+70^\circ\text{C}$  for HPC46164/HPC46104,  $-40^\circ\text{C}$  to  $+85^\circ\text{C}$  for HPC36164/HPC36104,  $-40^\circ\text{C}$  to  $+105^\circ\text{C}$  for HPC26164/HPC26104,  $-55^\circ\text{C}$  to  $+125^\circ\text{C}$  for HPC16164/HPC16104

Symbol	Parameter	Min	Max	Units
	Resolution		8	bits
$f_{CCLK}$	Clock Frequency (Note 4)	0.1	1.6	MHz
$t_{CON} = 8.5/f_{CCLK}$	Conversion Time (Note 3)	5.3		$\mu\text{s}$
$V_{REF}$	Reference Voltage Input (AGND = 0V)	3.0	$V_{CC}$	V
	Total Unadjusted Error (Note 1) ( $V_{REF} = 5.000\text{V}$ )		$\pm 1/2$	LSB
$R_{VREF}$	Reference Input Resistance (Note 5)	1.6	4.8	$\text{k}\Omega$
	DC Common Mode Error		$\pm 1/4$	LSB
	Power Supply Sensitivity ( $V_{REF} = 5.000\text{V}$ , $V_{CC} = 5V \pm 10\%$ )		$\pm 1/4$	LSB
	Voltage Reference Tolerance ( $V_{REF}$ )		TBD	LSB
	Port D Input Capacitance (Note 5)		35	pF
	Analog Input Voltage Range (Note 2)	$\text{GND} - 0.05$	$V_{CC} + 0.05$	V
	On Channel Leakage		1	$\mu\text{A}$
	Off Channel Leakage		1	$\mu\text{A}$

**Note 1:** Total unadjusted error includes offset, full-scale, and multiplexer errors.

**Note 2:** 8 single-ended or 4 differential channels. Inherent sample and hold for single-ended inputs (GND = Pin 62).

**Note 3:** Conversion time does not include sample/hold time. Sample and hold time is  $2/f_{CCLK}$ .

**Note 4:** Clock supplied to A/D converter is derived from CK1. See A/D description for details.

**Note 5:** This is guaranteed by design and not tested.

## Timing Waveforms

CK1, CK2, ALE Timing Diagram

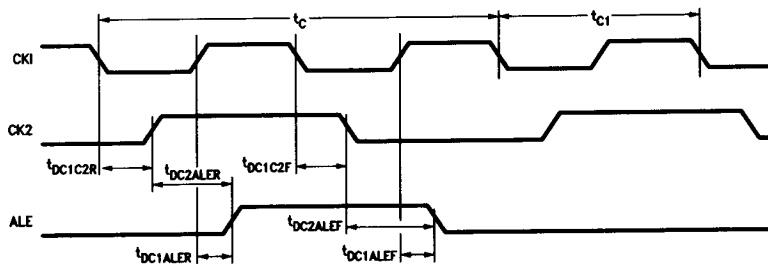

TL/DD/9682-2

# Timing Waveforms (Continued)

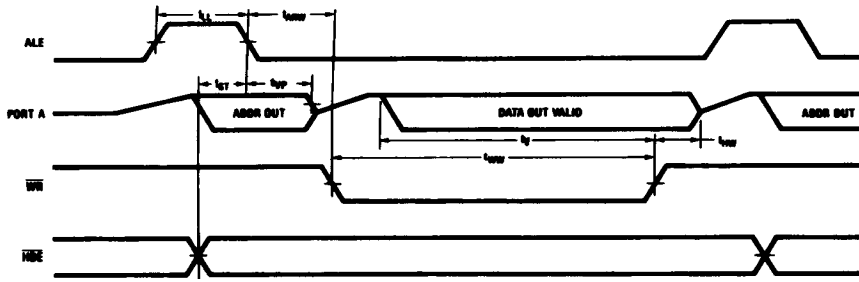

FIGURE 1. Write Cycle

TL/DD/9682-3

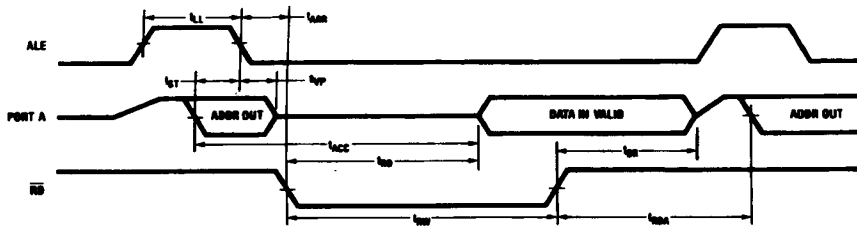

FIGURE 2. Read Cycle

TL/DD/9682-4

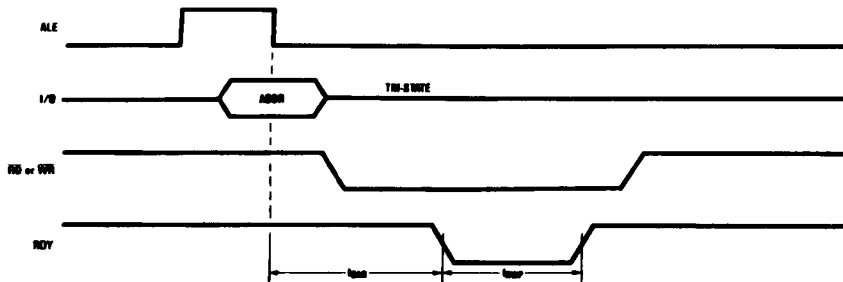

FIGURE 3. Ready Mode Timing

TL/DD/9682-5

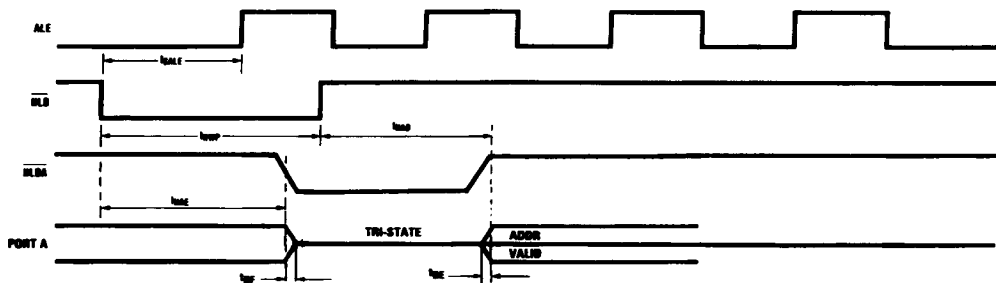

FIGURE 4. Hold Mode Timing

TL/DD/9682-6

# Timing Waveforms (Continued)

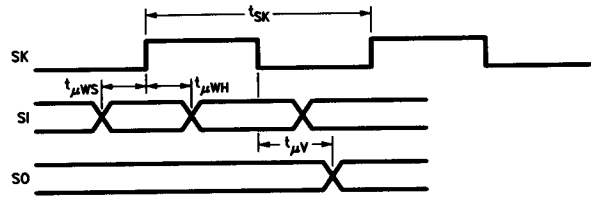

FIGURE 5. MICROWIRE Setup/Hold Timing

TL/DD/9682-39

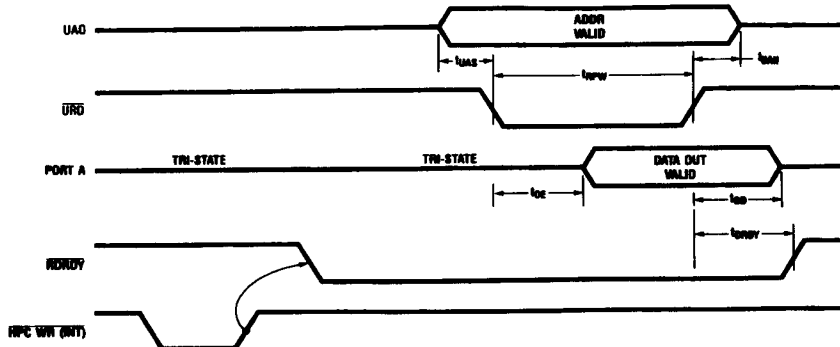

FIGURE 6. UPI Read Timing

TL/DD/9682-9

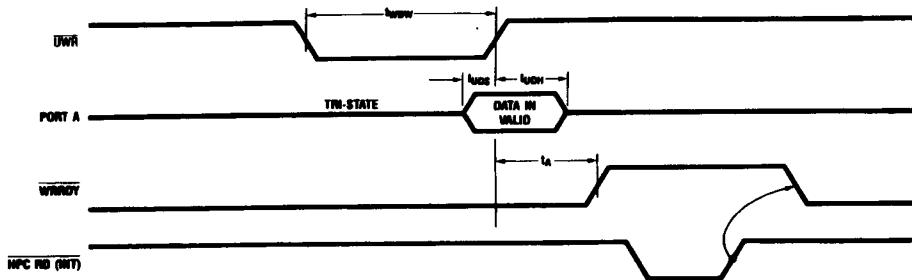

FIGURE 7. UPI Write Timing

TL/DD/9682-10

## Pin Descriptions

The HPC16164 is available in 68-pin PLCC, LCC, LDCC, PGA, and TapePak packages.

### I/O PORTS

Port A is a 16-bit bidirectional I/O port with a data direction register to enable each separate pin to be individually defined as an input or output. When accessing external memory, port A is used as the multiplexed address/data bus.

Port B is a 16-bit port with 12 bits of bidirectional I/O similar in structure to Port A. Pins B10, B11, B12 and B15 are general purpose outputs only in this mode. Port B may also be configured via a 16-bit function register BFUN to individually allow each pin to have an alternate function.

B0:	TDX	UART Data Output
B1:		
B2:	CKX	UART Clock (Input or Output)
B3:	T2IO	Timer2 I/O Pin
B4:	T3IO	Timer3 I/O Pin
B5:	SO	MICROWIRE/PLUS Output
B6:	SK	MICROWIRE/PLUS Clock (Input or Output)
B7:	<u>HLDA</u>	Hold Acknowledge Output
B8:	TS0	Timer Synchronous Output
B9:	TS1	Timer Synchronous Output
B10:	UA0	Address 0 Input for UPI Mode
B11:	<u>WRDY</u>	Write Ready Output for UPI Mode
B12:		
B13:	TS2	Timer Synchronous Output
B14:	TS3	Timer Synchronous Output
B15:	<u>RDRDY</u>	Read Ready Output for UPI Mode

When accessing external memory, four bits of port B are used as follows:

B10:	ALE	Address Latch Enable Output
B11:	<u>WR</u>	Write Output
B12:	HBE	High Byte Enable Output/Input (sampled at reset)
B15:	<u>RD</u>	Read Output

Port I is an 8-bit input port that can be read as general purpose inputs and is also used for the following functions:

I0:		
I1:	NMI	Nonmaskable Interrupt Input
I2:	INT2	Maskable Interrupt/Input Capture/ <u>URD</u>
I3:	INT3	Maskable Interrupt/Input Capture/ <u>UWR</u>
I4:	INT4	Maskable Interrupt/Input Capture
I5:	SI	MICROWIRE/PLUS Data Input
I6:	RDX	UART Data Input
I7:		

Port D is an 8-bit input port that can be used as general purpose digital inputs or as analog channel inputs for the A/D converter. These functions of Port D are mutually exclusive and under the control of software.

Port P is a 4-bit output port that can be used as general purpose data, or selected to be controlled by timers 4 through 7 in order to generate frequency, duty cycle and pulse width modulated outputs.

### POWER SUPPLY PINS

V <sub>CC1</sub>	and	Positive Power Supply
V <sub>CC2</sub>		Ground for On-Chip Logic
GND		Ground for Output Buffers
DGND		Ground for Output Buffers

**Note:** There are two electrically connected V<sub>CC</sub> pins on the chip, GND and DGND are electrically isolated. Both V<sub>CC</sub> pins and both ground pins must be used.

### CLOCK PINS

CKI	The Chip System Clock Input
CKO	The Chip System Clock Output (inversion of CKI)

Pins CKI and CKO are usually connected across an external crystal.

CK2	Clock Output (CKI divided by 2)
-----	---------------------------------

### OTHER PINS

WO This is an active low open drain output that signals an illegal situation has been detected by the Watch Dog logic.

ST1 Bus Cycle Status Output: indicates first op-code fetch.

ST2 Bus Cycle Status Output: indicates machine states (skip, interrupt and first instruction cycle).

RESET is an active low input that forces the chip to restart and sets the ports in a TRI-STATE® mode.

RDY/HLD has two uses, selected by a software bit. It's either a READY input to extend the bus cycle for slower memories, or a HOLD request input to put the bus in a high impedance state for DMA purposes.

VREF A/D converter reference voltage input.

EXM External memory enable (active high) disables internal ROM and maps it to external memory.

EI External interrupt with vector address FFF1:FFF0. (Rising/falling edge or high/low level sensitive). Alternately can be configured as 4th input capture.

AGND/EXUI has two uses, selected by a software bit. It can be an external active low interrupt which is internally OR'ed with the UART interrupt with vector address FFF3:FFF2 or it can be the analog ground for the A/D converter.

# Connection Diagrams

## Plastic, Leadless and Leaded Chip Carriers

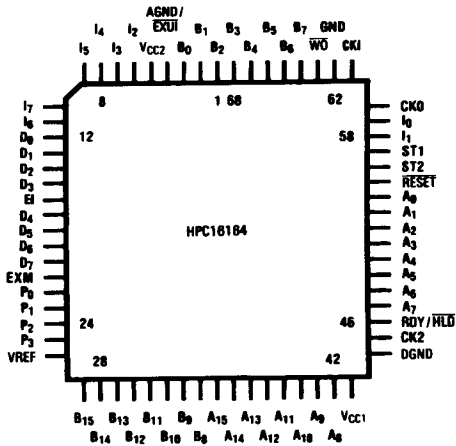

Top View

TL/DD/9682-11

## Pin Grid Array Pinout

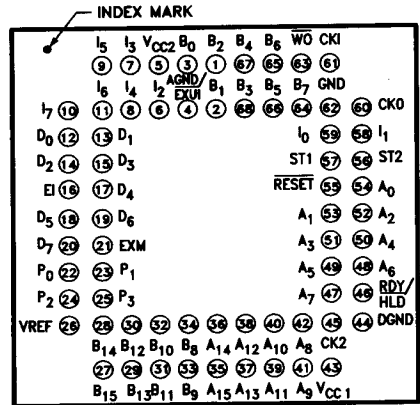

TL/DD/9682-12

Top View  
(looking down on component side of PC Board)

## TapePak Package

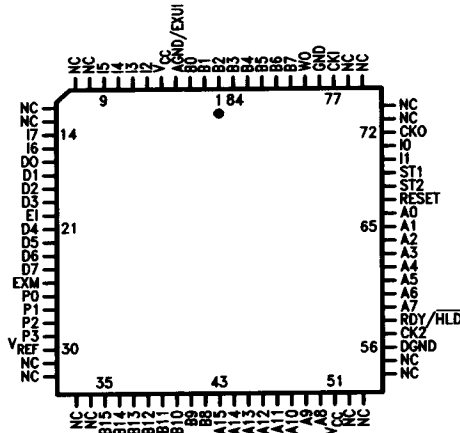

Top View

TL/DD/9682-36

## Operating Modes

To offer the user a variety of I/O and expanded memory options, the HPC16164 and HPC16104 have four operating modes. The ROMless HPC16104 has one mode of operation. The various modes of operation are determined by the state of both the EXM pin and the EA bit in the PSW register. The state of the EXM pin determines whether on-chip ROM will be accessed or external memory will be accessed within the address range of the on-chip ROM. The on-chip ROM range of the HPC16164 is C000 to FFFF (16k bytes). The HPC16104 has no on-chip ROM and is intended for use with external memory for program storage. A logic "0" state on the EXM pin will cause the HPC device to address on-chip ROM when the Program Counter (PC) contains addresses within the on-chip ROM address range. A logic "1" state on the EXM pin will cause the HPC device to address memory that is external to the HPC when the PC contains on-chip ROM addresses. The EXM pin should always be pulled high (logic "1") on the HPC16104 because no on-chip ROM is available. The function of the EA bit is to determine the legal addressing range of the HPC device. A logic "0" state in the EA bit of the PSW register does two things—addresses are limited to the on-chip ROM range and on-chip RAM and Register range, and the "illegal address detection" feature of the Watchdog logic is engaged. A logic "1" in the EA bit enables accesses to be made anywhere within the 64k byte address range and the "illegal address detection" feature of the Watchdog logic is disabled. The EA bit should be set to "1" by software when using the HPC16104 to disable the "illegal address detection" feature of Watchdog.

All HPC devices can be used with external memory. External memory may be any combination of RAM and ROM. Both 8-bit and 16-bit external data bus modes are available. Upon entering an operating mode in which external memory is used, port A becomes the Address/Data bus. Four pins of port B become the control lines ALE,  $\overline{RD}$ ,  $\overline{WR}$  and HBE. The High Byte Enable pin ( $\overline{HBE}$ ) is used in 16-bit mode to select high order memory bytes. The  $\overline{RD}$  and  $\overline{WR}$  signals are only generated if the selected address is off-chip. The 8-bit mode is selected by pulling HBE high at reset. If HBE is left floating or connected to a memory device chip select at reset, the 16-bit mode is entered. The following sections describe the operating modes of the HPC16164 and HPC16104.

**Note:** The HPC devices use 16-bit words for stack memory. Therefore, when using the 8-bit mode, User's Stack must be in internal RAM.

## HPC16164/HPC16064 Operating Modes

### SINGLE CHIP NORMAL MODE

In this mode, the HPC16164/HPC16064 functions as a self-contained microcomputer (see *Figure 11*) with all memory

(RAM and ROM) on-chip. It can address internal memory only, consisting of 16k bytes of ROM (C000 to FFFF) and 512 bytes of on-chip RAM and Registers (0000 to 02FF). The "illegal address detection" feature of the Watchdog is enabled in the Single-Chip Normal mode and a Watchdog Output (WO) will occur if an attempt is made to access addresses that are outside of the on-chip ROM and RAM range of the device. Ports A and B are used for I/O functions and not for addressing external memory. The EXM pin and the EA bit of the PSW register must both be logic "0" to enter the Single-Chip Normal mode.

### EXPANDED NORMAL MODE

The Expanded Normal mode of operation enables the HPC16164 to address external memory in addition to the on-chip ROM and RAM (see Table II). Watchdog illegal address detection is disabled and memory accesses may be made anywhere in the 64k byte address range without triggering an illegal address condition. The Expanded Normal mode is entered with the EXM pin pulled low (logic "0") and setting the EA bit in the PSW register to "1".

### SINGLE-CHIP ROMLESS MODE

In this mode, the on-chip mask programmed ROM of the HPC16164 is not used. The address space corresponding to the on-chip ROM is mapped into external memory so 16k of external memory may be used with the HPC16164 (see Table II). The Watchdog circuitry detects illegal addresses (addresses not within the on-chip ROM and RAM range). The Single-Chip ROMless mode is entered when the EXM pin is pulled high (logic "1") and the EA bit is logic "0".

### EXPANDED ROMLESS MODE

This mode of operation is similar to Single-Chip ROMless mode in that no on-chip ROM is used, however, a full 64k bytes of external memory may be used. The "illegal address detection" feature of Watchdog is disabled. The EXM pin must be pulled high (logic "1") and the EA bit in the PSW register set to "1" to enter this mode.

TABLE II. HPC16164 Operating Modes

Operating Mode	EXM Pin	EA Bit	Memory Configuration
Single-Chip Normal	0	0	C000:FFFF on-chip
Expanded Normal	0	1	C000:FFFF on-chip 0300:BFFF off-chip
Single-Chip ROMless	1	0	C000:FFFF off-chip
Expanded ROMless	1	1	0300:FFFF off-chip

**Note:** In all operating modes, the on-chip RAM and Registers (0000:02FF) may be accessed.



## Ports A & B

The highly flexible A and B ports are similarly structured. The Port A (see *Figure 7*), consists of a data register and a direction register. Port B (see *Figures 8, 9 and 10*) has an alternate function register in addition to the data and direction registers. All the control registers are read/write registers.

The associated direction registers allow the port pins to be individually programmed as inputs or outputs. Port pins selected as inputs, are placed in a TRI-STATE mode by resetting corresponding bits in the direction register.

A write operation to a port pin configured as an input causes the value to be written into the data register, a read operation returns the value of the pin. Writing to port pins configured as outputs causes the pins to have the same value, reading the pins returns the value of the data register.

Primary and secondary functions are multiplexed onto Port B through the alternate function register (BFUN). The secondary functions are enabled by setting the corresponding bits in the BFUN register.

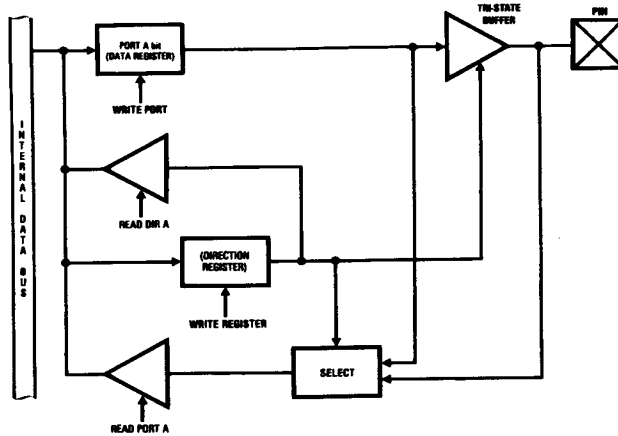

FIGURE 7. Port A: I/O Structure

TL/DD/9682-13

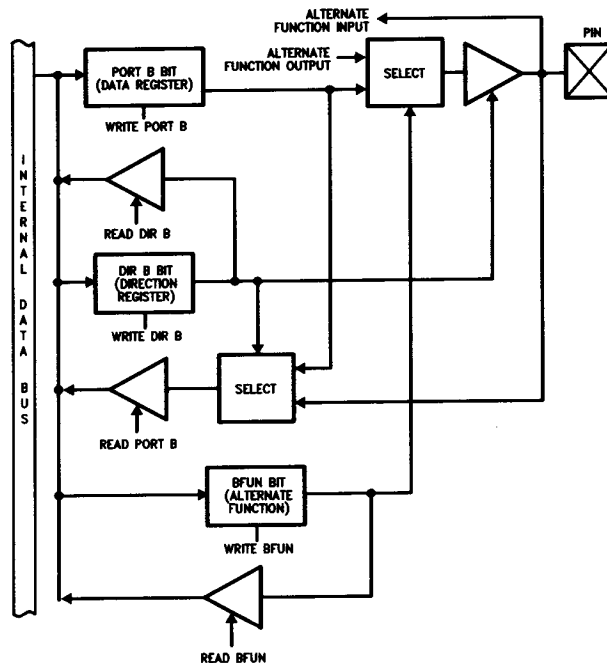

FIGURE 8. Structure of Port B Pins B0, B1, B2, B5, B6 and B7 (Typical Pins)

TL/DD/9682-14

# Ports A & B (Continued)

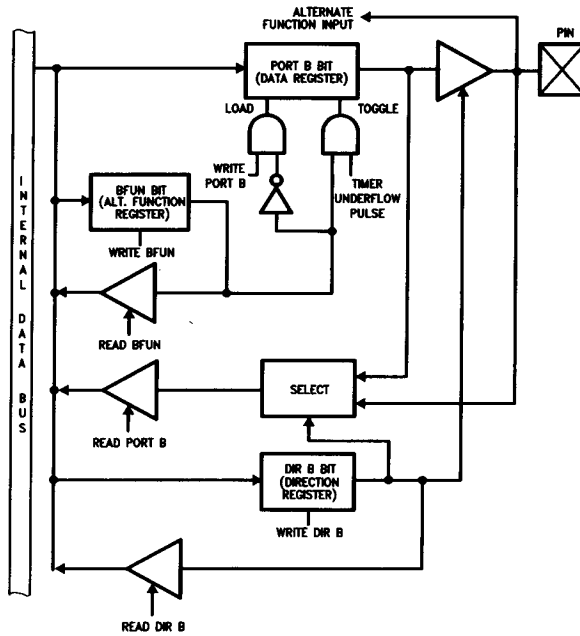

FIGURE 9. Structure of Port B Pins B3, B4, B8, B9, B13 and B14 (Timer Synchronous Pins)

TL/DD/9682-15

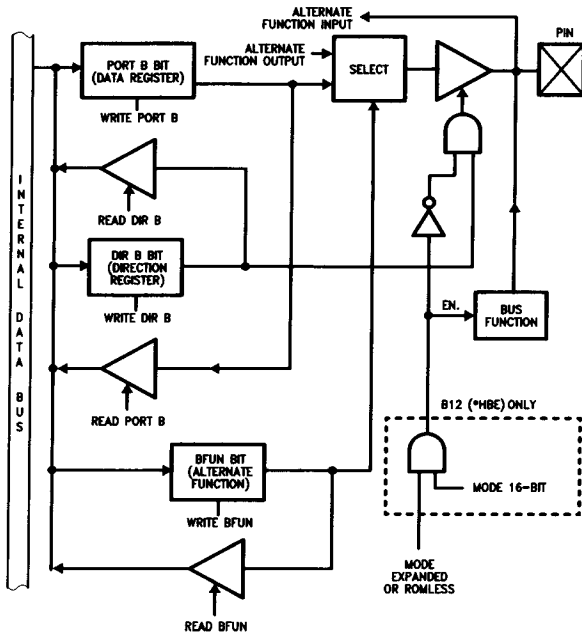

FIGURE 10. Structure of Port B Pins B10, B11, B12 and B15 (Pins with Bus Control Roles)

TL/DD/9682-16

# HPC16164 Operating Modes (Continued)

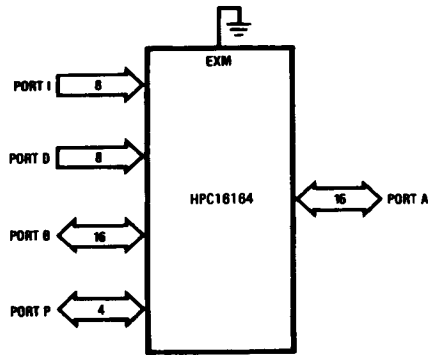

FIGURE 11. Single-Chip Mode

TL/DD/9682-17

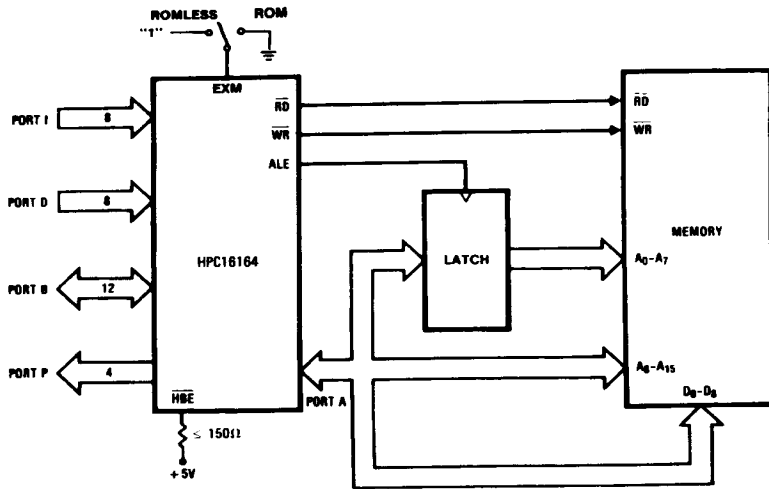

FIGURE 12. 8-Bit External Memory

TL/DD/9682-18

## HPC16164 Operating Modes (Continued)

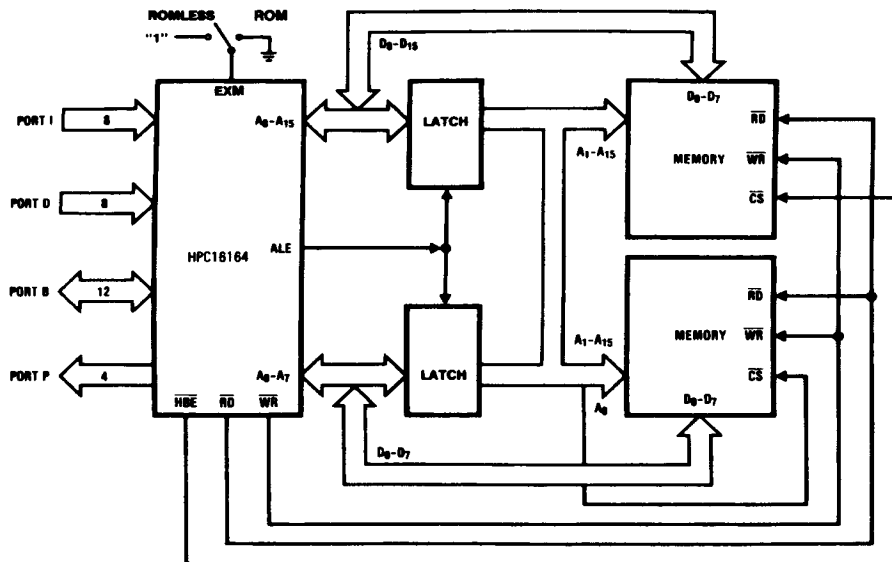

FIGURE 13. 16-Bit External Memory

TL/DD/9682-19

## HPC16104/HPC16004 Operating Modes

### EXPANDED ROMLESS MODE (HPC16104/HPC16004)

Because the HPC16104 has no on-chip ROM, it has only one mode of operation, the Expanded ROMless Mode. The EXM pin must be pulled high (logic "1") on power up, the EA bit in the PSW register should be set to a "1". The HPC16104/HPC16004 is a ROMless device and is intended for use with external memory. The external memory may be any combination of ROM and RAM. Up to 64k bytes of external memory may be accessed. It is necessary to vector on reset to an address between C000 and FFFF, therefore the user should have external memory at these addresses. The EA bit in the PSW register must immediately be set to "1" at the beginning of the user's program to disable illegal address detection in the Watchdog logic.

TABLE III. HPC16104 Operating Modes

Operating Mode	EXM Pin	EA Bit	Memory Configuration
Expanded ROMless	1	1	0300:FFFF off-chip

Note: The on-chip RAM and Registers (0000:02FF) of the HPC16104 may be accessed at all times.

### Wait States

The internal ROM can be accessed at the maximum operating frequency with one wait state. With 0 wait states, internal ROM accesses are limited to  $\frac{2}{3} t_C$  max.

The HPC16164 provides four software selectable Wait States that allow access to slower memories. The Wait

States are selected by the state of two bits in the PSW register. Additionally, the RDY input may be used to extend the instruction cycle, allowing the user to interface with slow memories and peripherals.

### Power Save Modes

Two power saving modes are available on the HPC16164: HALT and IDLE. In the HALT mode, all processor activities are stopped. In the IDLE mode, the on-board oscillator and timer T0 are active but all other processor activities are stopped. In either mode, all on-board RAM, registers and I/O are unaffected.

#### HALT MODE

The HPC16164 is placed in the HALT mode under software control by setting bits in the PSW. All processor activities, including the clock and timers, are stopped. In the HALT mode, power requirements for the HPC16164 are minimal and the applied voltage ( $V_{CC}$ ) may be decreased without altering the state of the machine. There are two ways of exiting the HALT mode: via the RESET or the NMI. The RESET input reinitializes the processor. Use of the NMI input will generate a vectored interrupt and resume operation from that point with no initialization. The HALT mode can be enabled or disabled by means of a control register HALT enable. To prevent accidental use of the HALT mode the HALT enable register can be modified only once.

#### IDLE MODE

The HPC16164 is placed in the IDLE mode through the PSW. In this mode, all processor activity, except the on-board oscillator and Timer T0, is stopped. As with the HALT

## Power Save Modes (Continued)

mode, the processor is returned to full operation by the RESET or NMI inputs, but without waiting for oscillator stabilization. A timer T0 overflow will also cause the HPC16164 to resume normal operation.

## HPC16164 Interrupts

Complex interrupt handling is easily accomplished by the HPC16164's vectored interrupt scheme. There are eight possible interrupt sources as shown in Table IV.

TABLE IV. Interrupts

Vector Address	Interrupt Source	Arbitration Ranking
FFFF:FFFE	RESET	0
FFFF:FFFC	Nonmaskable external on rising edge of I1 pin	1
FFFFB:FFFA	External interrupt on I2 pin	2
FFFF9:FFF8	External interrupt on I3 pin	3
FFFF7:FFF6	External interrupt on I4 pin	4
FFFF5:FFF4	Overflow on internal timers	5
FFFF3:FFF2	Internal by on-board peripherals or external on EXUI	6
FFFF1:FFF0	External interrupt on EI pin	7

## Interrupt Arbitration

The HPC16164 contains arbitration logic to determine which interrupt will be serviced first if two or more interrupts occur simultaneously. The arbitration ranking is given in Table IV. The interrupt on Reset has the highest rank and is serviced first.

## Interrupt Processing

Interrupts are serviced after the current instruction is completed except for the RESET, which is serviced immediately. RESET and EXUI are level-LOW-sensitive interrupts and EI is programmable for edge-(RISING or FALLING) or level-(HIGH or LOW) sensitivity. All other interrupts are edge-sensitive. NMI is positive-edge sensitive. The external interrupts on I2, I3 and I4 can be software selected to be rising or falling edge. External interrupt (EXUI) is shared with the on-board peripherals, UART and A/D. The EXUI interrupt is level-LOW-sensitive. To select this interrupt, disable the ERI and ETI UART interrupts by resetting these enable bits in the ENUI register and disable the A/D function by resetting the ADEN bit in the A/D control register #3 (CR3). To select the on-board peripherals interrupt, leave this pin floating or tie it high if the A/D function is disabled. If the A/D function is enabled, this pin becomes the analog ground (AGND).

## Interrupt Control Registers

The HPC16164 allows the various interrupt sources and conditions to be programmed. This is done through the various control registers. A brief description of the different control registers is given below.

## INTERRUPT ENABLE REGISTER (ENIR)

RESET and the External interrupt on I1 are non-maskable interrupts. The other interrupts can be individually enabled or disabled. Additionally, a Global Interrupt Enable Bit in the ENIR Register allows the Maskable interrupts to be collectively enabled or disabled. Thus, in order for a particular interrupt to request service, both the individual enable bit and the Global Interrupt bit (GIE) have to be set.

## INTERRUPT PENDING REGISTER (IRPD)

The IRPD register contains a bit allocated for each interrupt vector. The occurrence of specified interrupt trigger conditions causes the appropriate bit to be set. There is no indication of the order in which the interrupts have been received. The bits are set independently of the fact that the interrupts may be disabled. IRPD is a Read/Write register. The bits corresponding to the maskable, external interrupts are normally cleared by the HPC16164 after servicing the interrupts.

For the interrupts from the on-board peripherals, the user has the responsibility of resetting the interrupt pending flags through software.

The NMI bit is read only and I2, I3, and I4 are designed as to only allow a zero to be written to the pending bit (writing a one has no effect). A LOAD IMMEDIATE instruction is to be the only instruction used to clear a bit or bits in the IRPD register. This allows a mask to be used, thus ensuring that the other pending bits are not affected.

## INTERRUPT CONDITION REGISTER (IRCD)

Three bits of the register select the input polarity of the external interrupt on I2, I3, and I4.

## Servicing the Interrupts

The Interrupt, once acknowledged, pushes the program counter (PC) onto the stack thus incrementing the stack pointer (SP) twice. The Global Interrupt Enable bit (GIE) is copied into the CGIE bit of the PSW register; it is then reset, thus disabling further interrupts. The program counter is loaded with the contents of the memory at the vector address and the processor resumes operation at this point. At the end of the interrupt service routine, the user does a RETI instruction to pop the stack and re-enable interrupts if the CGIE bit is set, or RET to just pop the stack if the CGIE bit is clear, and then returns to the main program. The GIE bit can be set in the interrupt service routine to nest interrupts if desired. Figure 14 shows the Interrupt Enable Logic.

## Reset

The RESET input initializes the processor and sets ports A and B in the TRI-STATE condition and Port P in the LOW state. RESET is an active-low Schmitt trigger input. The processor vectors to FFFF:FFFE and resumes operation at the address contained at that memory location (which must correspond to an on board location). The Reset vector address must be between C000 and FFFF when using the HPC16104.

# Servicing the Interrupts (Continued)

TL/DD/9682-20

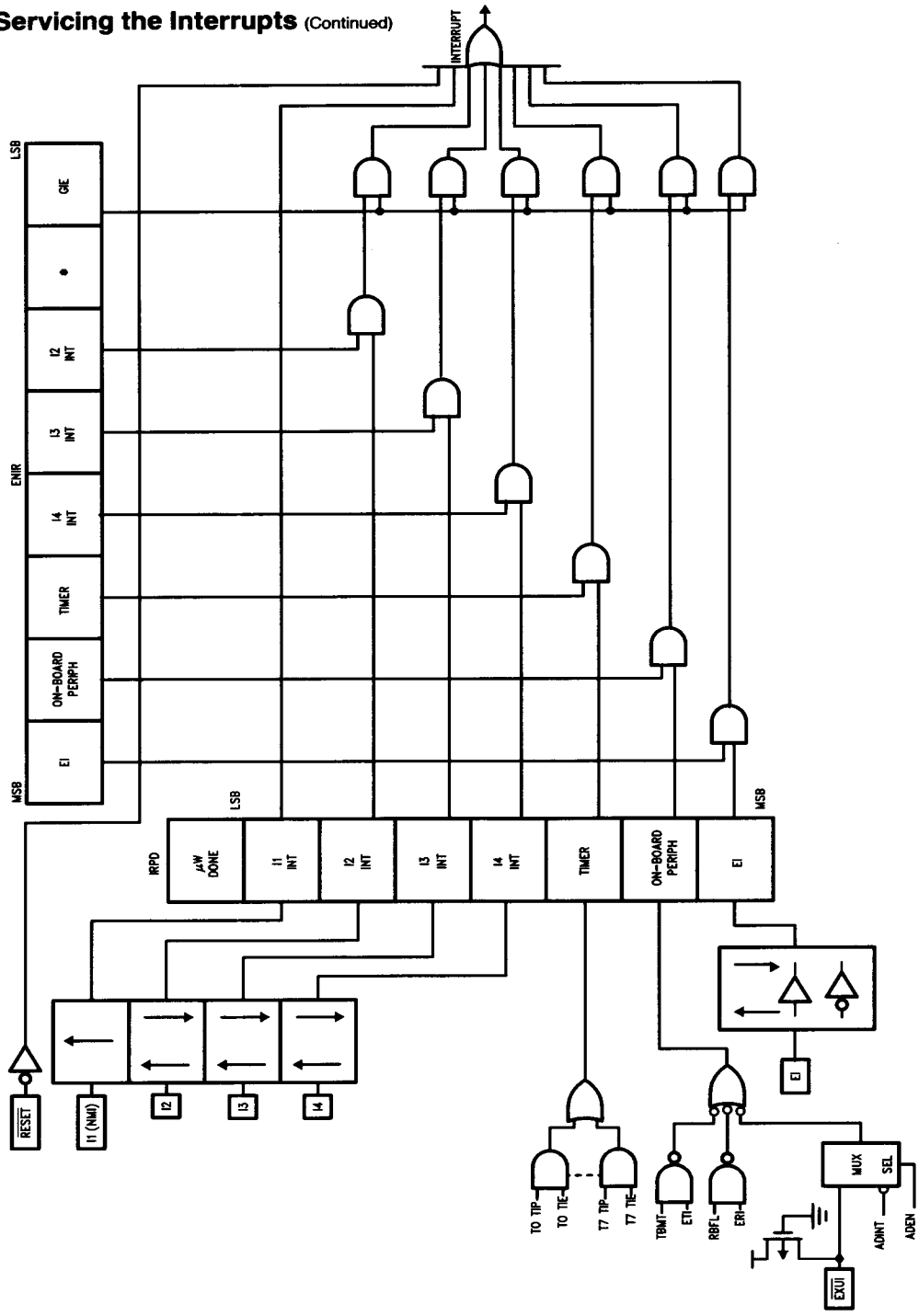

FIGURE 14. Block Diagram of Interrupt Logic

## Timer Overview

The HPC16164 contains a powerful set of flexible timers enabling the HPC16164 to perform extensive timer functions; not usually associated with microcontrollers.

The HPC16164 contains nine 16-bit timers. Timer T0 is a free-running timer, counting up at a fixed  $CKI/16$  (Clock Input/16) rate. It is used for Watchdog logic, high speed event capture, and to exit from the IDLE mode. Consequently, it cannot be stopped or written to under software control. Timer T0 permits precise measurements by means of the capture registers I2CR, I3CR, and I4CR. A control bit in the register TMODE configures timer T1 and its associated register R1 as capture registers I2CR and I2CR. The capture registers I2CR, I3CR, and I4CR respectively, record the value of timer T0 when specific events occur on the interrupt pins I2, I3, and I4. The control register IRCD programs the capture registers to trigger on either a rising edge or a falling edge of its respective input. The specified edge can also be programmed to generate an interrupt (see *Figure 15*).

The HPC16164 provides an additional 16-bit free running timer, T8, with associated input capture register EICR (External Interrupt Capture Register) and Configuration Register, EICON. EICON is used to select the mode and edge of the EI pin. EICR is a 16-bit capture register which records the value of T8 (which is identical to T0) when a specific event occurs on the EI pin.

The timers T2 and T3 have selectable clock rates. The clock input to these two timers may be selected from the following two sources: an external pin, or derived internally by dividing the clock input. Timer T2 has additional capability of being clocked by the timer T3 underflow. This allows the user to cascade timers T3 and T2 into a 32-bit timer/counter. The control register DIVBY programs the clock input to timers T2 and T3 (see *Figure 16*).

The timers T1 through T7 in conjunction with their registers form Timer-Register pairs. The registers hold the pulse duration values. All the Timer-Register pairs can be read from

or written to. Each timer can be started or stopped under software control. Once enabled, the timers count down, and upon underflow, the contents of its associated register are automatically loaded into the timer.

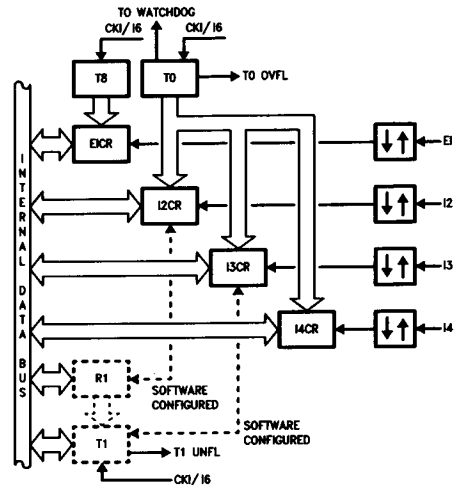

TL/DD/9682-21

**FIGURE 15. Timers T0, T1 and T8 with Four Input Capture Registers**

### SYNCHRONOUS OUTPUTS

The flexible timer structure of the HPC16164 simplifies pulse generation and measurement. There are four synchronous timer outputs (TS0 through TS3) that work in conjunction with the timer T2. The synchronous timer outputs can be used either as regular outputs or individually programmed to toggle on timer T2 underflows (see *Figure 16*).

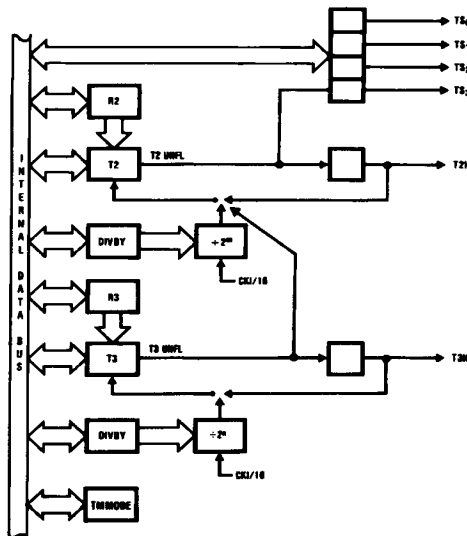
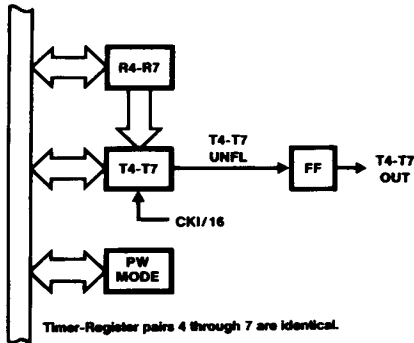

**FIGURE 16. Timers T2-T3 Block**

TL/DD/9682-22

## Timer Overview (Continued)

Timer/register pairs 4–7 form four identical units which can generate synchronous outputs on port P (see Figure 17). Maximum output frequency for any timer output can be obtained by setting timer/register pair to zero. This then will produce an output frequency equal to  $\frac{1}{2}$  the frequency of the source used for clocking the timer.



TL/DD/9682-23

FIGURE 17. Timers T4–T7 Block

## Timer Registers

There are four control registers that program the timers. The divide by (DIVBY) register programs the clock input to timers T2 and T3. The timer mode register (TMMODE) contains control bits to start and stop timers T1 through T3. It also contains bits to latch, acknowledge and enable interrupts from timers T0 through T3. The control register PWMODE similarly programs the pulse width timers T4 through T7 by allowing them to be started, stopped, and to latch and enable interrupts on overflows. The PORTP register contains bits to preset the outputs and enable the synchronous timer output functions.

## Timer Applications

The use of Pulse Width Timers for the generation of various waveforms is easily accomplished by the HPC16164.

Frequencies can be generated by using the timer/register pairs. A square wave is generated when the register value is a constant. The duty cycle can be controlled simply by changing the register value.



TL/DD/9682-24

FIGURE 18. Square Wave Frequency Generation

Synchronous outputs based on Timer T2 can be generated on the 4 outputs TS0–TS3. Each output can be individually programmed to toggle on T2 underflow. Register R2 contains the time delay between events. Figure 19 is an example of synchronous pulse train generation.

## Watchdog Logic

The Watchdog Logic monitors the operations taking place and signals upon the occurrence of any illegal activity. The illegal conditions that trigger the Watchdog logic are poten-

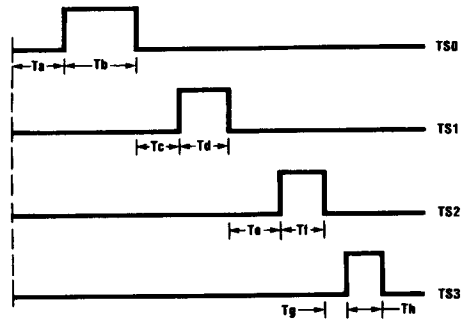

TL/DD/9682-25

FIGURE 19. Synchronous Pulse Generation

tially infinite loops and illegal addresses. Should the Watchdog register not be written to before Timer T0 overflows twice, or more often than once every 4096 counts, an infinite loop condition is assumed to have occurred. An illegal condition also occurs when the processor generates an illegal address when in the Single-Chip modes.\* Any illegal condition forces the Watchdog Output (W $\bar{O}$ ) pin low. The W $\bar{O}$  pin is an open drain output and can be connected to the RESET or NMI inputs or to the users external logic.

\*Note: See Operating Modes for details.

## MICROWIRE/PLUS

MICROWIRE/PLUS is used for synchronous serial data communications (see Figure 20). MICROWIRE/PLUS has an 8-bit parallel-loaded, serial shift register using SI as the input and SO as the output. SK is the clock for the serial shift register (SIO). The SK clock signal can be provided by an internal or external source. The internal clock rate is programmable by the DIVBY register. A DONE flag indicates when the data shift is completed.

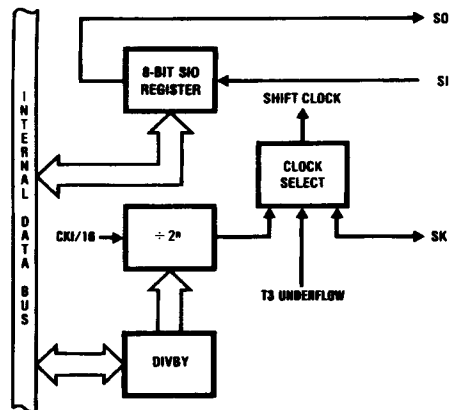

TL/DD/9682-26

FIGURE 20. MICROWIRE/PLUS

The MICROWIRE/PLUS capability enables it to interface with any of National Semiconductor's MICROWIRE peripherals (i.e., A/D converters, display drivers, EEPROMs).



## MICROWIRE/PLUS Operation

The HPC16164 can enter the MICROWIRE/PLUS mode as the master or a slave. A control bit in the IRCD register determines whether the HPC16164 is the master or slave. The shift clock is generated when the HPC16164 is configured as a master. An externally generated shift clock on the SK pin is used when the HPC16164 is configured as a slave. When the HPC16164 is a master, the DIVBY register programs the frequency of the SK clock. The DIVBY register allows the SK clock frequency to be programmed in 15 selectable steps from 64 Hz to 1 MHz with CKI at 16.0 MHz.

The contents of the SIO register may be accessed through any of the memory access instructions. Data waiting to be transmitted in the SIO register is clocked out on the falling edge of the SK clock. Serial data on the SI pin is clocked in on the rising edge of the SK clock.

## MICROWIRE/PLUS Application

Figure 21 illustrates a MICROWIRE/PLUS arrangement for an automotive application. The microcontroller-based sys-

tem could be used to interface to an instrument cluster and various parts of the automobile. The diagram shows two HPC16164 microcontrollers interconnected to other MICROWIRE peripherals. HPC16164 #1 is set up as the master and initiates all data transfers. HPC16164 #2 is set up as a slave answering to the master.

The master microcontroller interfaces the operator with the system and could also manage the instrument cluster in an automotive application. Information is visually presented to the operator by means of an LCD display controlled by the COP472 display driver. The data to be displayed is sent serially to the COP472 over the MICROWIRE/PLUS link. Data such as accumulated mileage could be stored and retrieved from the EEPROM COP494. The slave HPC16164 could be used as a fuel injection processor and generate timing signals required to operate the fuel valves. The master processor could be used to periodically send updated values to the slave via the MICROWIRE/PLUS link. To speed up the response, chip select logic is implemented by connecting an output from the master to the external interrupt input on the slave.

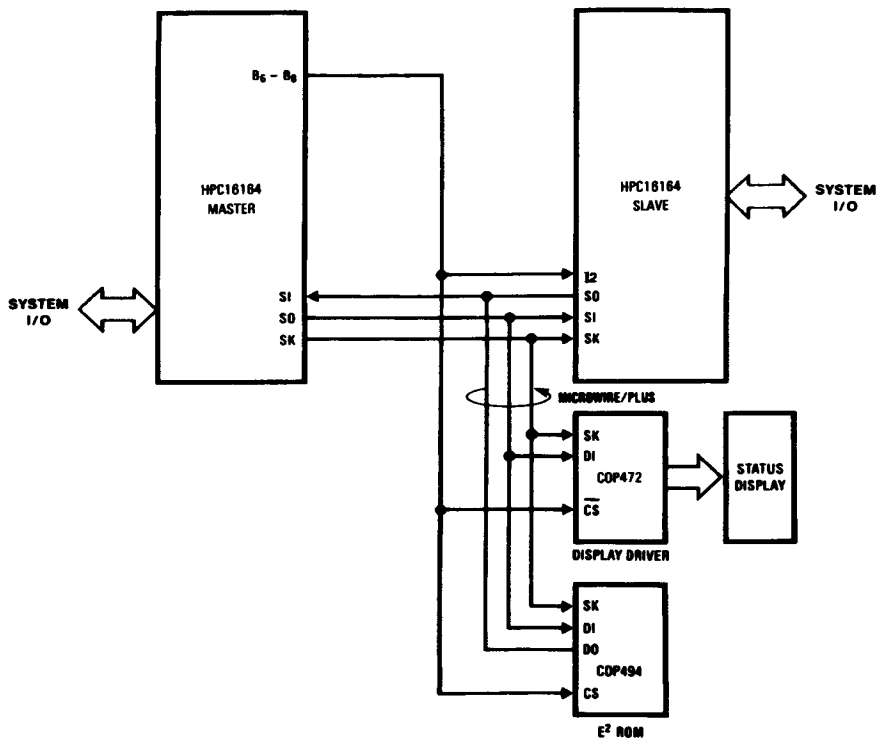

FIGURE 21. MICROWIRE/PLUS Application

TL/DD/9682-27

## HPC16164 UART

The HPC16164 contains a software programmable UART. The UART (see *Figure 22*) consists of a transmit shift register, a receiver shift register and five addressable registers, as follows: a transmit buffer register (TBUF), a receiver buffer register (RBUF), a UART control and status register (ENU), a UART receive control and status register (ENUR) and a UART interrupt and clock source register (ENUI). The ENU register contains flags for transmit and receive functions; this register also determines the length of the data frame (8 or 9 bits) and the value of the ninth bit in transmission. The ENUR register flags framing and data overrun errors while the UART is receiving. Other functions of the ENUR register include saving the ninth bit received in the data frame and enabling or disabling the UART's Wake-up Mode of operation. The determination of an internal or external clock source is done by the ENUI register, as well as selecting the number of stop bits and enabling or disabling transmit and receive interrupts.

The baud rate clock for the Receiver and Transmitter can be selected for either an internal or external source using two bits in the ENUI register. The internal baud rate is programmed by the DIVBY register. The baud rate may be selected from a range of 8 Hz to 128 kHz in binary steps or T3 underflow. By selecting a 9.83 MHz crystal, all standard baud rates from 75 baud to 38.4 kBaud can be generated. The external baud clock source comes from the CKX pin. The Transmitter and Receiver can be run at different rates by selecting one to operate from the internal clock and the other from an external source.

The HPC16164 UART supports two data formats. The first format for data transmission consists of one start bit, eight data bits and one or two stop bits. The second data format for transmission consists of one start bit, nine data bits, and one or two stop bits. Receiving formats differ from transmission only in that the Receiver always requires only one stop bit in a data frame.

### UART Wake-up Mode

The HPC16164 UART features a Wake-up Mode of operation. This mode of operation enables the HPC16164 to be networked with other processors. Typically in such environments, the messages consist of addresses and actual data. Addresses are specified by having the ninth bit in the data frame set to 1. Data in the message is specified by having the ninth bit in the data frame reset to 0.

The UART monitors the communication stream looking for addresses. When the data word with the ninth bit set is received, the UART signals the HPC16164 with an interrupt. The processor then examines the content of the receiver buffer to decide whether it has been addressed and whether to accept subsequent data.

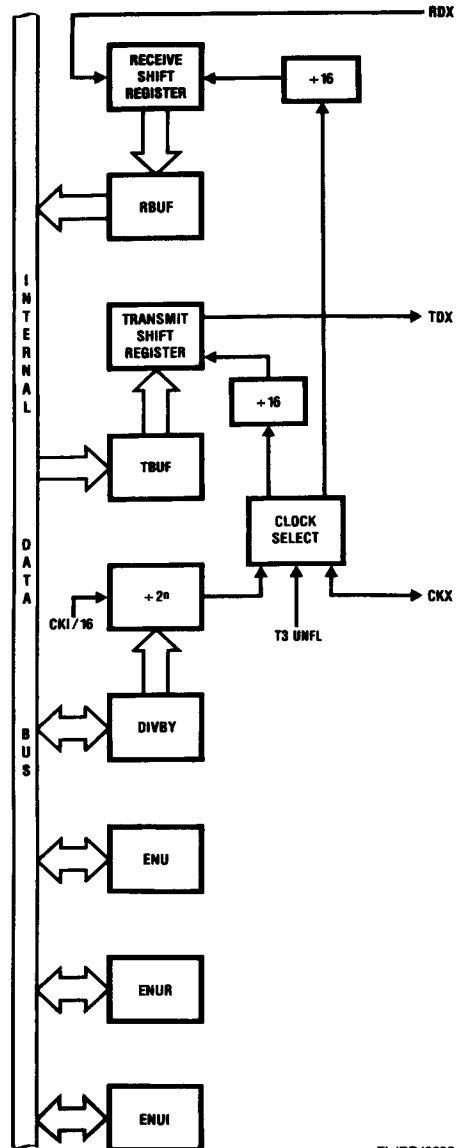

FIGURE 22. UART Block Diagram

TL/DD/9682-28

# A/D Converter Operation

TL/DD/9862-28

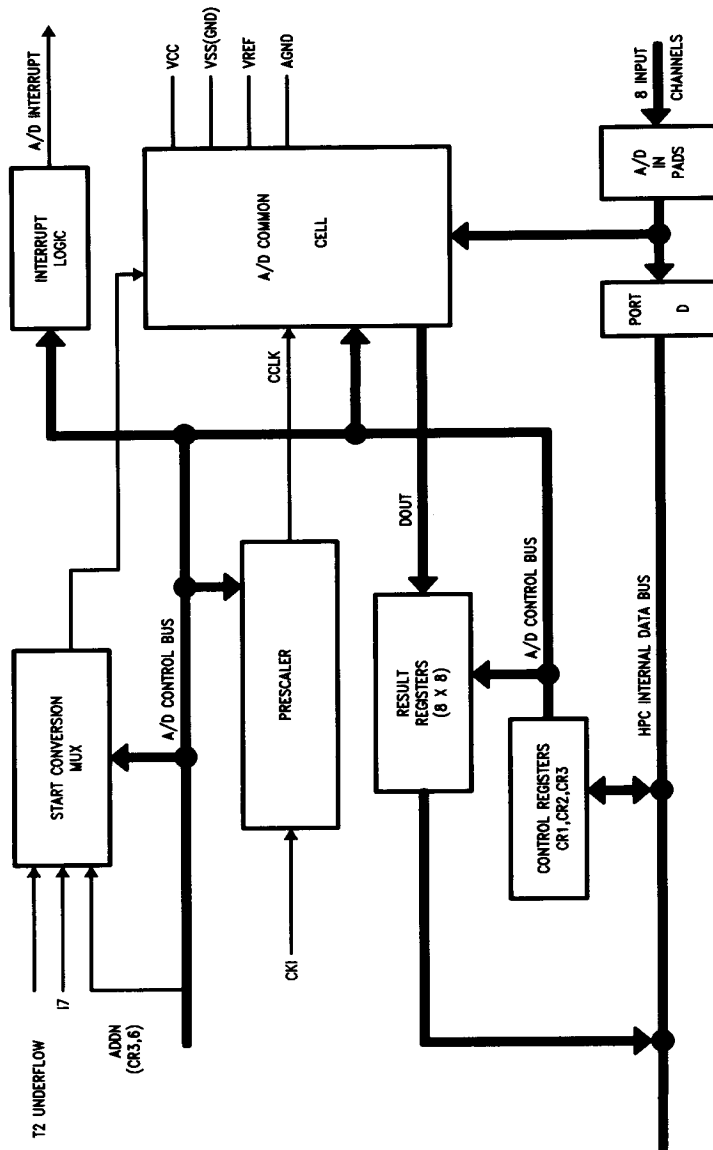

FIGURE 23. A/D Block Diagram

## A/D Converter Operation (Continued)

The HPC16164 has an on-board eight-channel 8-bit Analog to Digital converter. Conversion is performed using a successive approximation technique. The A/D converter cell can operate in single-ended mode where the input voltage is applied across one of the eight input channels (D0–D7) and AGND or in differential mode where the input voltage is applied across two adjacent input channels. The A/D converter will convert up to eight channels in single-ended mode and up to four channel-pairs in differential mode.

### OPERATING MODES

The operating modes of the converter are selected by 4 bits called ADMODE (CR2.4–7). Associated with the eight input channels in single-ended mode are eight result registers, one for each channel. The A/D converter can be programmed by software to convert on any specific channel storing the result in the result register associated with that channel. It can also be programmed to stop after one conversion or to convert continuously. If a brief history of the signal on any specific input channel is required, the converter can be programmed to convert on that channel and store the consecutive results in each of the result registers before stopping. As a final configuration in single-ended mode, the converter can be programmed to convert the signal on each input channel and store the result in its associated result register continuously.

Associated with each even-odd pair of input channels in differential mode of operation are four result register-pairs. The A/D converter performs two conversions on the selected pair of input channels. One conversion is performed assuming the positive connection is made to the even channel and the negative connection is made to the following odd channel. This result is stored in the result register associated with the even channel. Another conversion is performed assuming the positive connection is made to the odd channel and the negative connection is made to the preceding even channel. This result is stored in the result register associated with the odd channel. This technique does not require that the programmer know the polarity of the input signal. If the even channel result register is non-zero (meaning the odd channel result register is zero), then the input signal is positive with respect to the odd channel. If the odd channel result register is non-zero (meaning the even channel result register is zero), then the input signal is positive with respect to the even channel.

The same operating modes for single-ended operation also apply when the inputs are taken from channel-pairs in differential mode. The programmer can configure the A/D to convert on any selected channel-pair and store the result in its associated result register-pair then stop. The A/D can also be programmed to do this continuously. Conversion can also be done any channel-pair storing the result into four result register-pairs for a history of the differential input. Finally, all input channel-pairs can be converted continuously. The final mode of operation suppresses the external address/data bus activity during the single conversion modes. These quiet modes of operation utilize the RDY function of the HPC Core to insert wait states in the instruction being executed in order to limit digital noise in the environment due to external bus activity when addressing external memory. The overall effect is to increase the accuracy of the A/D.

### CONTROL

The conversion clock supplied to the A/D converter can be selected by three bits in CR1 used as a prescaler on CKI. These bits can be used to ensure that the A/D is clocked as fast as possible when different external crystal frequencies are used. Controlling the starting of conversion cycles in each of the operating modes can be done by four different methods. The method is selected by two bits called SC (CR3.0–1). Conversion cycles can be initiated through software by resetting a bit in a control register, through hardware by an underflow of Timer T2, or externally by a rising or falling edge of a signal input on I7.

### INTERRUPTS

The A/D converter can interrupt the HPC when it completes a conversion cycle if one of the non-continuous modes has been selected. If one of the cycle modes was selected, then the converter will request an interrupt after eight conversions. If one of the one-shot modes was selected, then the converter will request an interrupt after every conversion. When this interrupt is generated, the HPC vectors to the on-board peripheral interrupt vector location at address FFF2. The service routine must then determine if the A/D converter requested the interrupt by checking the A/D done flag which doubles as the A/D interrupt pending flag.

### REGISTER MAP

The A/D converter status and control registers and the result registers are detailed as follows:

#### Control Register #1 (CR1)

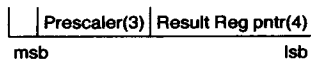

byte at location 0100

**Result Register pointer**—These four bits are read/only by the software. In all the operating modes that are single channel or single channel-pair, this pointer gets the value of the Channel Select bits (CR2.0–3) and remains constant. In the operating modes that work on multiple channels or multiple channel-pairs, this pointer gets initialized to zero and will change to reflect the current channel that is being converted (default value on power-up is 0000).

**Prescaler**—These three bits are used to select the clock (CCLK) supplied to the SAR in the A/D converter cell. The maximum clock that can be supplied is 1.67 MHz and the minimum is 100 kHz. Therefore, these bits can be used to ensure that the A/D is clocked as fast as possible at different external crystal frequencies.

000 = stop the clock (CCLK) to the A/D cell (default value on power-up)

011 = use CKI/4 to allow max CKI of 6.66 MHz

010 = use CKI/8 to allow max CKI of 13.33 MHz

111 = use CKI/12 to allow max CKI of 20 MHz

101 = use CKI/16 to allow max CKI of 26.66 MHz

001 = use CKI/20 to allow max CKI of 33.33 MHz

110 = use CKI/24 to allow max CKI of 40 MHz

100 = use CKI/32 to allow max CKI of 53.4 MHz

**Note:** All remaining unused bits in this control register are UNDEFINED and not available for use by the program.

## A/D Converter Operation (Continued)

### Control Register #2 (CR2)

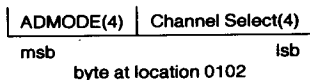

**ADMODE**—These four bits are used to select the mode of operation for the A/D converter as described in OPERATING MODES.

- 0000 = single-ended, single channel, single result register, one-shot (default value on power-up)
- 0001 = single-ended, single channel, single result register, continuous
- 0010 = single-ended, single channel, multiple result registers, stop after 8
- 0011 = differential, multiple channel, multiple result registers, continuous
- 0100 = differential, single channel-pair, single result register-pair, one-shot
- 0101 = differential, single channel-pair, single result register-pair, continuous
- 0110 = differential, single channel-pair, multiple result register-pairs, stop after 4 pairs
- 0111 = differential, multiple channel-pair, multiple result register-pairs, continuous

**Channel Select**—These four bits are used to select the channel on which to initiate conversions.

#### Single-ended

- x000 = Convert on Channel 0 (Input Port D.0)
- x001 = Convert on Channel 1 (Input Port D.1)
- x010 = Convert on Channel 2 (Input Port D.2)
- x011 = Convert on Channel 3 (Input Port D.3)
- x100 = Convert on Channel 4 (Input Port D.4)
- x101 = Convert on Channel 5 (Input Port D.5)
- x110 = Convert on Channel 6 (Input Port D.6)
- x111 = Convert on Channel 7 (Input Port D.7)

#### Differential

- x000 = Convert on Channel-Pair 0,1
- x010 = Convert on Channel-Pair 2,3
- x100 = Convert on Channel-Pair 4,5
- x110 = Convert on Channel-Pair 6,7

### Control Register #3 (CR3)

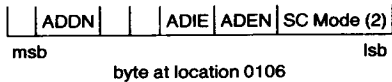

**SC mode**—These two bits are used to select the mode for starting a conversion cycle.

- 00 = A conversion cycle is initiated by resetting the A/D done flag (ADDN) (default value on power-up).

- 01 = A conversion cycle is initiated by an underflow of Timer T2.

- 10 = A conversion cycle is initiated by the falling edge of the signal on input I7.

- 11 = A conversion cycle is initiated by the rising edge of the signal on input I7.

**ADEN**—Setting this bit enables pin 4 to be the analog ground, AGND. Resetting this bit returns pin 4 as EXUI (reset on power-up).

**ADIE**—This is the A/D interrupt enable bit. (reset on power-up).

**ADDN**—This bit is the A/D done flag and doubles as the A/D interrupt pending flag. If one of the one-shot modes was selected using ADMODE(=xx00) and control was selected as SC = 00, then this bit must be reset by software to initiate the conversion and is set by the hardware at the end of one conversion. If one of the cycle modes was selected using ADMODE(=xx10) and control was selected as SC = 00, then this bit must be reset by software to initiate the conversion cycle and is not set by the hardware until the end of one conversion cycle. If any of the continuous modes were selected and control was selected as SC = 00, then this bit must be reset by software to initiate the conversions and is not set by the hardware until the clock to the A/D cell is stopped by selecting the value 000 for the prescaler. In all other control selections, this bit has no effect on the initiation of conversions but is still necessary for proper interrupt operation. The ADDN flag must also be reset for the quiet modes to work properly (set on power-up).

**Note:** All remaining unused bits in this control register are UNDEFINED and not available for use by the program. Also, all result register contents are UNDEFINED on power-up.

## Universal Peripheral Interface

The Universal Peripheral Interface (UPI) allows the HPC16164 to be used as an intelligent peripheral to another processor. The UPI could thus be used to tightly link two HPC16164's and set up systems with very high data exchange rates. Another area of application could be where a HPC16164 is programmed as an intelligent peripheral to a host system such as the Series 32000<sup>®</sup> microprocessor. *Figure 24* illustrates how a HPC16164 could be used as an intelligent peripheral for a Series 32000-based application.

The interface consists of a Data Bus (port A), a Read Strobe ( $\overline{URD}$ ), a Write Strobe ( $\overline{UWR}$ ), a Read Ready Line ( $\overline{RDRDY}$ ), a Write Ready Line ( $\overline{WRRDY}$ ) and one Address Input (UA0). The data bus can be either eight or sixteen bits wide.

The  $\overline{URD}$  and  $\overline{UWR}$  inputs may be used to interrupt the HPC16164. The  $\overline{RDRDY}$  and  $\overline{WRRDY}$  outputs may be used to interrupt the host processor.

The UPI contains an Input Buffer (IBUF), an Output Buffer (OBUF) and a Control Register (UPIC). In the UPI mode, port A on the HPC16164 is the data bus. UPI can only be used if the HPC16164 is in the Single-Chip mode.

## Shared Memory Support

Shared memory access provides a rapid technique to exchange data. It is effective when data is moved from a peripheral to memory or when data is moved between blocks of memory. A related area where shared memory access proves effective is in multiprocessing applications where two CPUs share a common memory block. The HPC16164 supports shared memory access with two pins. The pins are the RDY/HLD input pin and the HLDA output pin. The user can software select either the Hold or Ready function by the state of a control bit. The HLDA output is multiplexed onto port B.

The host uses DMA to interface with the HPC16164. The host initiates a data transfer by activating the HLD input of

the HPC16164. In response, the HPC16164 places its system bus in a TRI-STATE Mode, freeing it for use by the host. The host waits for the acknowledge signal (HLDA) from the HPC16164 indicating that the system bus is free. On receiving the acknowledge, the host can rapidly transfer data into, or out of, the shared memory by using a conventional DMA controller. Upon completion of the message transfer, the host removes the HOLD request and the HPC16164 resumes normal operations.

To insure proper operation, the interface logic shown is recommended as the means for enabling and disabling the user's bus. Figure 25 illustrates an application of the shared memory interface between the HPC16164 and a Series 32000 system.

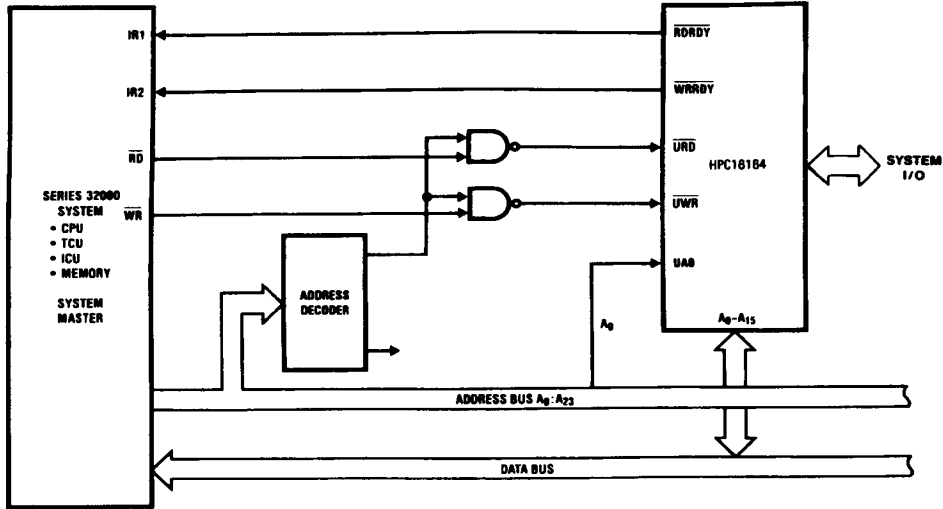

FIGURE 24. HPC16164 as a Peripheral: (UPI Interface to Series 32000 Application)

TL/DD/9682-30

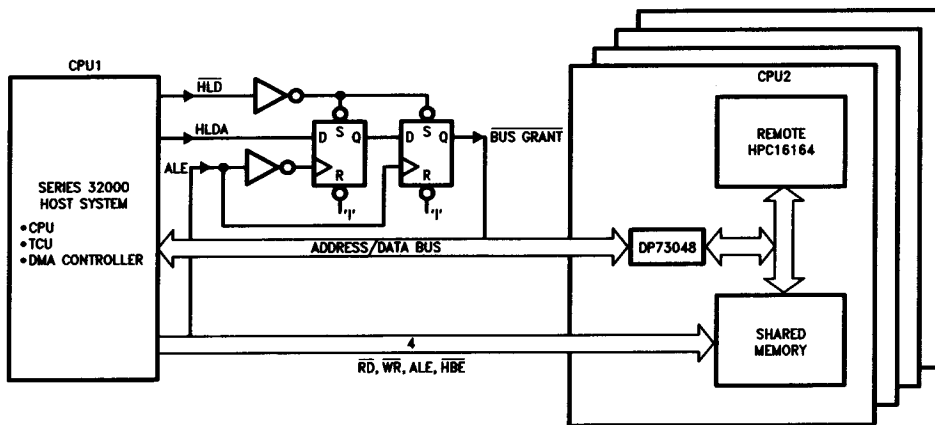

FIGURE 25. Shared Memory Application: HPC16164 Interface to Series 32000 System

TL/DD/9682-31

## Memory

The HPC16164 has been designed to offer flexibility in memory usage. A total address space of 64 kbytes can be addressed with 16 kbytes of ROM and 512 bytes of RAM available on the chip itself. The ROM may contain program instructions, constants or data. The ROM and RAM share the same address space allowing instructions to be executed out of RAM.

Program memory addressing is accomplished by the 16-bit program counter on a byte basis. Memory can be addressed

directly by instructions or indirectly through the B, X and SP registers. Memory can be addressed as words or bytes. Words are always addressed on even-byte boundaries. The HPC16164 uses memory-mapped organization to support registers, I/O and on-chip peripheral functions.

The HPC16164 memory address space extends to 64 kbytes and registers and I/O are mapped as shown in Table V.

**TABLE V. HPC16164 Memory Map**

FFFF:FFF0 FFEF:FFD0 FFCF:FFC0 : : E001:C000	Interrupt Vectors JSRP Vectors  On-Chip ROM*	USER MEMORY	011F:011E 011D:011C 011B:011A 0119:0118 0117:0116 0115:0114 0113:0112 0111:0110 0106	A/D Result Register 7 A/D Result Register 6 A/D Result Register 5 A/D Result Register 4 A/D Result Register 3 A/D Result Register 2 A/D Result Register 1 A/D Result Register 0 A/D Control Register #3	A to D Registers†
BFFF:BFFE : : 0301:0300	External Expansion Memory		0104	Port D Input Register	
02FF:02FE : : 01C1:01C0	On-Chip RAM	USER RAM	0102 0100	A/D Control Register #2 A/D Control Register #1	A to D Registers†
0195:0194	Watchdog Address	Watchdog Logic	00F5:00F4 00F3:00F2 00F1:00F0	BFUN Register DIR B Register DIR A Register / IBUF	PORTS A & B CONTROL
0192 0191:0190 018F:018E 018D:018C 018B:018A 0189:0188 0187:0186 0185:0184 0183:0182 0181:0180	T0CON Register TMMODE Register DIVBY Register T3 Timer R3 Register T2 Timer R2 Register I2CR Register/ R1 I3CR Register/ T1 I4CR Register	Timer Block T0:T3	00E6	UPIC Register	UPI CONTROL
015E:015F 015C 0153:0152 0151:0150 014F:014E 014D:014C 014B:014A 0149:0148 0147:0146 0145:0144 0143:0142 0141:0140	EICR EICON Port P Register PWMODE Register R7 Register T7 Timer R6 Register T6 Timer R5 Register T5 Timer R4 Register T4 Timer	Timer Block T4:T7	00E3:00E2 00E1:00E0	Port B Port A / OBUF	PORTS A & B
0128 0126 0124 0122 0120	ENUR Register TBUF Register RBUF Register ENUJ Register ENU Register	UART	00DE 00DD:00DC 00D8 00D6 00D4 00D2 00D0	Microcode ROM Dump HALT Enable Register Port I Input Register SIO Register IRCD Register IRPD Register ENIR Register	PORT CONTROL & INTERRUPT CONTROL REGISTERS
			00CF:00CE 00CD:00CC 00CB:00CA 00C9:00C8 00C7:00C6 00C5:00C4 00C3:00C2 00C0	X Register B Register K Register A Register PC Register SP Register (reserved) PSW Register	HPC CORE REGISTERS
			00BF:00BE : : 0001:0000	On-Chip RAM	USER RAM

\*Note: The HPC16164 and HPC18064 On-Chip ROM is on addresses C000:FFFF and the External Expansion Memory is 0300:BFFF. The HPC16104 and HPC16004 have no On-Chip ROM, External Memory is 0300:FFFF.

†Note: Only one HPC16164 and HPC16104 have on-board A/D.

## Design Considerations

Designs using the HPC family of 16-bit high speed CMOS microcontrollers need to follow some general guidelines on usage and board layout.

Floating inputs are a frequently overlooked problem. CMOS inputs have extremely high impedance and, if left open, can float to any voltage. You should thus tie unused inputs to  $V_{CC}$  or ground, either through a resistor or directly. Unlike the inputs, unused output should be left floating to allow the output to switch without drawing any DC current.

To reduce voltage transients, keep the supply line's parasitic inductances as low as possible by reducing trace lengths, using wide traces, ground planes, and by decoupling the supply with bypass capacitors. In order to prevent additional voltage spiking, this local bypass capacitor must exhibit low inductive reactance. You should therefore use high frequency ceramic capacitors and place them very near the IC to minimize wiring inductance.

- Keep  $V_{CC}$  bus routing short. When using double sided or multilayer circuit boards, use ground plane techniques.
- Keep ground lines short, and on PC boards make them as wide as possible, even if trace width varies. Use separate ground traces to supply high current devices such as relay and transmission line drivers.
- In systems mixing linear and logic functions and where supply noise is critical to the analog components' performance, provide separate supply buses or even separate supplies.
- If you use local regulators, bypass their inputs with a tantalum capacitor of at least  $1\ \mu\text{F}$  and bypass their outputs with a  $10\ \mu\text{F}$  to  $50\ \mu\text{F}$  tantalum or aluminum electrolytic capacitor.
- If the system uses a centralized regulated power supply, use a  $10\ \mu\text{F}$  to  $20\ \mu\text{F}$  tantalum electrolytic capacitor or a  $50\ \mu\text{F}$  to  $100\ \mu\text{F}$  aluminum electrolytic capacitor to decouple the  $V_{CC}$  bus connected to the circuit board.
- Provide localized decoupling. For random logic, a rule of thumb dictates approximately  $10\ \text{nF}$  (spaced within  $12\ \text{cm}$ ) per every two to five packages, and  $100\ \text{nF}$  for every 10 packages. You can group these capacitances, but it's more effective to distribute them among the ICs. If the design has a fair amount of synchronous logic with outputs that tend to switch simultaneously, additional decoupling might be advisable. Octal flip-flop and buffers in bus-oriented circuits might also require more decoupling. Note that wire-wrapped circuits can require more decoupling than ground plane or multilayer PC boards.

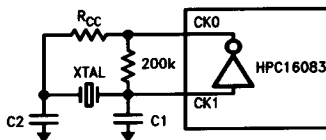

TL/DD/9682-41

A recommended crystal oscillator circuit to be used with the HPC is shown below. See table for recommended component values. The recommended values given in the table below have yielded consistent results and are made to match a crystal with a  $20\ \text{pF}$  load capacitance, with some small allowance for layout capacitance.

A recommended layout for the oscillator network should be as close to the processor as physically possible, entirely within "1" distance. This is to reduce lead inductance from long PC traces, as well as interference from other components, and reduce trace capacitance. The layout contains a large ground plane either on the top or bottom surface of the board to provide signal shielding, and a convenient location to ground both the HPC, and the case of the crystal.

It is very critical to have an extremely clean power supply for the HPC crystal oscillator. Ideally one would like a  $V_{CC}$  and ground plane that provide low inductance power lines to the chip. The power planes in the PC board should be decoupled with three decoupling capacitors as close to the chip as possible. A  $1.0\ \mu\text{F}$ , a  $0.1\ \mu\text{F}$ , and a  $0.001\ \mu\text{F}$  dipped mica or ceramic cap mounted as close to the HPC as is physically possible on the board, using the shortest leads, or surface mount components. This should provide a stable power supply, and noiseless ground plane which will vastly improve the performance of the crystal oscillator network.

HPC Oscillator Table

$f_c$ (MHz)	$R_{CC}$ ( $\Omega$ )	$C_1$ (pF)	$C_2$ (pF)
2	50	82	100
4	50	62	75
6	50	50	56
8	50	47	50
10	50	39	50
12	0	39	39
14	0	33	39
16	0	33	39
18	0	33	33
20	0	33	33
22	0	27	39
24	0	27	39
26	0	27	33
28	0	27	33
30	0	27	27

### Crystal Specifications:

"AT" cut, parallel resonant crystals tuned to the desired frequency with the following specifications are recommended:

Series resistance <  $65\ \Omega$

Loading capacitance:  $C_L = 20\ \text{pF}$



## HPC16164 CPU

The HPC16164 CPU has a 16-bit ALU and six 16-bit registers

### Arithmetic Logic Unit (ALU)

The ALU is 16 bits wide and can do 16-bit add, subtract and shift or logic AND, OR and exclusive OR in one timing cycle. The ALU can also output the carry bit to a 1-bit C register.

### Accumulator (A) Register

The 16-bit A register is the source and destination register for most I/O, arithmetic, logic and data memory access operations.

### Address (B and X) Registers

The 16-bit B and X registers can be used for indirect addressing. They can automatically count up or down to sequence through data memory.

### Boundary (K) Register

The 16-bit K register is used to set limits in repetitive loops of code as register B sequences through data memory.

### Stack Pointer (SP) Register

The 16-bit SP register is the pointer that addresses the stack. The SP register is incremented by two for each push or call and decremented by two for each pop or return. The stack can be placed anywhere in user memory and be as deep as the available memory permits.

### Program (PC) Register

The 16-bit PC register addresses program memory.

## Addressing Modes

### ADDRESSING MODES—ACCUMULATOR AS DESTINATION

#### Register Indirect

This is the "normal" mode of addressing for the HPC16164 (instructions are single-byte). The operand is the memory addressed by the B register (or X register for some instructions).

#### Direct

The instruction contains an 8-bit or 16-bit address field that directly points to the memory for the operand.

#### Indirect

The instruction contains an 8-bit address field. The contents of the WORD addressed points to the memory for the operand.

#### Indexed

The instruction contains an 8-bit address field and an 8- or 16-bit displacement field. The contents of the WORD addressed is added to the displacement to get the address of the operand.

#### Immediate

The instruction contains an 8-bit or 16-bit immediate field that is used as the operand.

#### Register Indirect (Auto Increment and Decrement)

The operand is the memory addressed by the X register. This mode automatically increments or decrements the X register (by 1 for bytes and by 2 for words).

#### Register Indirect (Auto Increment and Decrement) with Conditional Skip

The operand is the memory addressed by the B register. This mode automatically increments or decrements the B register (by 1 for bytes and by 2 for words). The B register is then compared with the K register. A skip condition is generated if B goes past K.

### ADDRESSING MODES—DIRECT MEMORY AS DESTINATION

#### Direct Memory to Direct Memory

The instruction contains two 8- or 16-bit address fields. One field directly points to the source operand and the other field directly points to the destination operand.

#### Immediate to Direct Memory

The instruction contains an 8- or 16-bit address field and an 8- or 16-bit immediate field. The immediate field is the operand and the direct field is the destination.

#### Double Register Indirect Using the B and X Registers

Used only with Reset, Set and IF bit instructions; a specific bit within the 64 kbyte address range is addressed using the B and X registers. The address of a byte of memory is formed by adding the contents of the B register to the most significant 13 bits of the X register. The specific bit to be modified or tested within the byte of memory is selected using the least significant 3 bits of register X.

## HPC Instruction Set Description

Mnemonic	Description	Action
<b>ARITHMETIC INSTRUCTIONS</b>		
ADD	Add	$MA + Mem1 \rightarrow MA$ carry $\rightarrow C$
ADC	Add with carry	$MA + Mem1 + C \rightarrow MA$ carry $\rightarrow C$
ADDS	Add short imm8	$A + imm8 \rightarrow A$ carry $\rightarrow C$
DADC	Decimal add with carry	$MA + Mem1 + C \rightarrow MA$ (Decimal) carry $\rightarrow C$
SUBC	Subtract with carry	$MA - Mem1 + C \rightarrow MA$ carry $\rightarrow C$
DSUBC	Decimal subtract w/carry	$MA - Mem1 + C \rightarrow MA$ (Decimal) carry $\rightarrow C$
MULT	Multiply (unsigned)	$MA * Mem1 \rightarrow MA \& X, 0 \rightarrow K, 0 \rightarrow C$
DIV	Divide (unsigned)	$MA / Mem1 \rightarrow MA, rem. \rightarrow X, 0 \rightarrow K, 0 \rightarrow C$
DIVD	Divide Double Word (unsigned)	$X \& MA / Mem1 \rightarrow MA, rem \rightarrow X, 0 \rightarrow K, Carry \rightarrow C$
IFEQ	If equal	Compare MA & Mem1, Do next if equal
IFGT	If greater than	Compare MA & Mem1, Do next if MA > Mem1
AND	Logical and	$MA \text{ and } Mem1 \rightarrow MA$
OR	Logical or	$MA \text{ or } Mem1 \rightarrow MA$
XOR	Logical exclusive-or	$MA \text{ xor } Mem1 \rightarrow MA$
<b>MEMORY MODIFY INSTRUCTIONS</b>		
INC	Increment	$Mem + 1 \rightarrow Mem$
DECSZ	Decrement, skip if 0	$Mem - 1 \rightarrow Mem$ , Skip next if Mem = 0

## HPC Instruction Set Description (Continued)

Mnemonic	Description	Action
<b>BIT INSTRUCTIONS</b>		
SBIT RBIT IFBIT	Set bit Reset bit If bit	1 → Mem.bit 0 → Mem.bit If Mem.bit is true, do next instr.
<b>MEMORY TRANSFER INSTRUCTIONS</b>		
LD ST X PUSH POP LDS XS	Load Load, incr/decr X Store to Memory Exchange Exchange, incr/decr X Push Memory to Stack Pop Stack to Memory Load A, incr/decr B, Skip on condition Exchange, incr/decr B, Skip on condition	Mem1 → MA Mem(X) → A, X ± 1 (or 2) → X A → Mem A ↔ Mem A ↔ Mem(X), X ± 1 (or 2) → X W → W(SP), SP + 2 → SP SP - 2 → SP, W(SP) → W Mem(B) → A, B ± 1 (or 2) → B, Skip next if B greater/less than K Mem(B) ↔ A, B ± 1 (or 2) → B, Skip next if B greater/less than K
<b>REGISTER LOAD IMMEDIATE INSTRUCTIONS</b>		
LD B LD K LD X LD BK	Load B immediate Load K immediate Load X immediate Load B and K immediate	imm → B imm → K imm → X imm → B, imm → K
<b>ACCUMULATOR AND C INSTRUCTIONS</b>		
CLR A INC A DEC A COMP A SWAP A RRC A RLC A SHR A SHL A SC RC IFC IFNC	Clear A Increment A Decrement A Complement A Swap nibbles of A Rotate A right thru C Rotate A left thru C Shift A right Shift A left Set C Reset C IF C IF not C	0 → A A + 1 → A A - 1 → A 1's complement of A → A A15:12 ← A11:8 ← A7:4 ↔ A3:0 C → A15 → ... → A0 → C C ← A15 ← ... ← A0 ← C 0 → A15 → ... → A0 → C C ← A15 ← ... ← A0 ← 0 1 → C 0 → C Do next if C = 1 Do next if C = 0
<b>TRANSFER OF CONTROL INSTRUCTIONS</b>		
JSRP JSR JSRL JP JMP JMPL JID JIDW NOP RET RETSK RETI	Jump subroutine from table Jump subroutine relative Jump subroutine long Jump relative short Jump relative Jump relative long Jump indirect at PC + A No Operation Return Return then skip next Return from interrupt	PC → W(SP), SP + 2 → SP W(table#) → PC PC → W(SP), SP + 2 → SP, PC + # → PC (# is +1025 to -1023) PC → W(SP), SP + 2 → SP, PC + # → PC PC + # → PC (# is +32 to -31) PC + # → PC (# is +257 to -255) PC + # → PC PC + A + 1 → PC then Mem(PC) + PC → PC PC + 1 → PC SP - 2 → SP, W(SP) → PC SP - 2 → SP, W(SP) → PC, & skip SP - 2 → SP, W(SP) → PC, interrupt re-enabled
<p><b>Note:</b> W is 16-bit word of memory MA is Accumulator A or direct memory (8 or 16-bit) Mem is 8-bit byte or 16-bit word of memory Mem1 is 8- or 16-bit memory or 8 or 16-bit immediate data imm is 8-bit or 16-bit immediate data imm8 is 8-bit immediate data only</p>		

# Memory Usage

Number Of Bytes For Each Instruction (number in parenthesis is 16-Bit field)

	Using Accumulator A						To Direct Memory			
	Reg Indir.		Direct	Indir	Index	Immed.	Direct		Immed.	
	(B)	(X)					.	..	.	..
LD	1	1	2(4)	3	4(5)	2(3)	3(5)	5(6)	3(4)	5(6)
X	1	1	2(4)	3	4(5)	—	—	—	—	—
ST	1	1	2(4)	3	4(5)	—	—	—	—	—
ADC	1	2	3(4)	3	4(5)	4(5)	4(5)	5(6)	4(5)	5(6)
ADDS	—	—	—	—	—	2	—	—	—	—
SBC	1	2	3(4)	3	4(5)	4(5)	4(5)	5(6)	4(5)	5(6)
DADC	1	2	3(4)	3	4(5)	4(5)	4(5)	5(6)	4(5)	5(6)
DSBC	1	2	3(4)	3	4(5)	4(5)	4(5)	5(6)	4(5)	5(6)
ADD	1	2	3(4)	3	4(5)	2(3)	4(5)	5(6)	4(5)	5(6)
MULT	1	2	3(4)	3	4(5)	2(3)	4(5)	5(6)	4(5)	5(6)
DIV	1	2	3(4)	3	4(5)	2(3)	4(5)	5(6)	4(5)	5(6)
DIVD	1	2	3(4)	3	4(5)	—	4(5)	5(6)	4(5)	5(6)
IFEQ	1	2	3(4)	3	4(5)	2(3)	4(5)	5(6)	4(5)	5(6)
IFGT	1	2	3(4)	3	4(5)	2(3)	4(5)	5(6)	4(5)	5(6)
AND	1	2	3(4)	3	4(5)	2(3)	4(5)	5(6)	4(5)	5(6)
OR	1	2	3(4)	3	4(5)	2(3)	4(5)	5(6)	4(5)	5(6)
XOR	1	2	3(4)	3	4(5)	2(3)	4(5)	5(6)	4(5)	5(6)

\*8-bit direct address  
\*\*16-bit direct address

## Instructions that modify memory directly

	(B)	(X)	Direct	Indir	Index	B&X
SBIT	1	2	3(4)	3	4(5)	1
RBIT	1	2	3(4)	3	4(5)	1
IFBIT	1	2	3(4)	3	4(5)	1
DECSZ	3	2	2(4)	3	4(5)	
INC	3	2	2(4)	3	4(5)	

## Immediate Load Instructions

	Immed.
LD B,*	2(3)
LD X,*	2(3)
LD K,*	2(3)
LD BK,*	3(5)

## Register Indirect Instructions with Auto Increment and Decrement

Register B With Skip		
	(B+)	(B-)
LDS A,*	1	1
XS A,*	1	1

Register X		
	(X+)	(X-)
LD A,*	1	1
X A,*	1	1

## Instructions Using A and C

CLR	A	1
INC	A	1
DEC	A	1
COMP	A	1
SWAP	A	1
RRC	A	1
RLC	A	1
SHR	A	1
SHL	A	1
SC		1
RC		1
IFC		1
IFNC		1

## Transfer of Control Instructions

JSRP	1
JSR	2
JSRL	3
JP	1
JMP	2
JMPL	3
JID	1
JIDW	1
NOP	1
RET	1
RETSK	1
RETI	1

## Stack Reference Instructions

	Direct
PUSH	2
POP	2

## Code Efficiency

One of the most important criteria of a single chip microcontroller is code efficiency. The more efficient the code, the more features that can be put on a chip. The memory size on a chip is fixed so if code is not efficient, features may have to be sacrificed or the programmer may have to buy a larger, more expensive version of the chip.

The HPC16164 has been designed to be extremely code-efficient. The HPC16164 looks very good in all the standard coding benchmarks; however, it is not realistic to rely only on benchmarks. Many large jobs have been programmed onto the HPC16164, and the code savings over other popular microcontrollers has been considerable.

Reasons for this saving of code include the following:

### SINGLE BYTE INSTRUCTIONS

The majority of instructions on the HPC16164 are single-byte. There are two especially code-saving instructions:

JP is a 1-byte jump. True, it can only jump within a range of plus or minus 32, but many loops and decisions are often within a small range of program memory. Most other micros need 2-byte instructions for any short jumps.

JSRP is a 1-byte call subroutine. The user makes a table of his 16 most frequently called subroutines and these calls will only take one byte. Most other micros require two and even three bytes to call a subroutine. The user does not have to decide which subroutine addresses to put into his table; the assembler can give him this information.

### EFFICIENT SUBROUTINE CALLS

The 2-byte JSR instructions can call any subroutine within plus or minus 1k of program memory.

### MULTIFUNCTION INSTRUCTIONS FOR DATA MOVEMENT AND PROGRAM LOOPING

The HPC16164 has single-byte instructions that perform multiple tasks. For example, the XS instruction will do the following:

1. Exchange A and memory pointed to by the B register
2. Increment or decrement the B register
3. Compare the B register to the K register
4. Generate a conditional skip if B has passed K

The value of this multipurpose instruction becomes evident when looping through sequential areas of memory and exiting when the loop is finished.

### BIT MANIPULATION INSTRUCTIONS

Any bit of memory, I/O or registers can be set, reset or tested by the single byte bit instructions. The bits can be addressed directly or indirectly. Since all registers and I/O are mapped into the memory, it is very easy to manipulate specific bits to do efficient control.

### DECIMAL ADD AND SUBTRACT

This instruction is needed to interface with the decimal user world.

It can handle both 16-bit words and 8-bit bytes.

The 16-bit capability saves code since many variables can be stored as one piece of data and the programmer does not have to break his data into two bytes. Many applications store most data in 4-digit variables. The HPC16164 supplies 8-bit byte capability for 2-digit variables and literal variables.

## MULTIPLY AND DIVIDE INSTRUCTIONS

The HPC16164 has 16-bit multiply, 16-bit by 16-bit divide, and 32-bit by 16-bit divide instructions. This saves both code and time. Multiply and divide can use immediate data or data from memory. The ability to multiply and divide by immediate data saves code since this function is often needed for scaling, base conversion, computing indexes of arrays, etc.

## Development Support

### DEVELOPMENT SYSTEM

The Microcomputer On Line Emulator (MOLE) is a low cost development system and emulator for all microcontroller products. These include COPSTM microcontrollers and the HPC family of products. The development system consists of a BRAIN Board, Personality Board and optional host software.

The purpose of the development system is to provide the user with a tool to write and assemble code, emulate code for the target microcontroller and assist in both software and hardware debugging of the system.

It is a self contained computer with its own firmware which provides for all system operation, emulation control, communication, PROM programming and diagnostic operations.

It contains three serial ports to optionally connect to a terminal, a host system, a printer or a modem, or to connect to other development systems in a multi-development system environment.

The development system can be used in either a stand alone mode or in conjunction with a selected host system using PC-DOS communicating via a RS-232 port.

### How to Order

To order a complete development package, select the section for the microcontroller to be developed and order the parts listed.

### DIAL-A-HELPER

Dial-A-Helper is a service provided by the Microcontroller Applications group. Dial-A-Helper is an Electronic Bulletin Board Information system and additionally, provides the capability of remotely accessing the MOLE development system at a customer site.

### INFORMATION SYSTEM

The Dial-A-Helper system provides access to an automated information storage and retrieval system that may be accessed over standard dial-up telephone lines 24 hours a day. The system capabilities include a MESSAGE SECTION (electronic mail) for communications to and from the Microcontroller Applications Group and a FILE SECTION which consists of several file areas where valuable application software and utilities can be found. The minimum requirement for accessing Dial-A-Helper is a Hayes compatible modem.

If the user has a PC with a communications package then files from the FILE SECTION can be down loaded to disk for later use.

### Order P/N: MOLE-DIAL-A-HLP

Information System Package Contains:  
Dial-A-Helper Users Manual  
Public Domain Communications Software

## Development Support (Continued)

### Development Tools Selection Table

Microcontroller	Order Part Number	Description	Includes	Manual Number
HPC	MOLE-BRAIN	Brain Board	Brain Board Users Manual	420408188-001
	MOLE-HPC-PB1	Personality Board	HPC Personality Board Users Manual	420410477-001
	MOLE-HPC-IBM-R	Relocatable Assembler Software for IBM	HPC Software Users Manual and Software Disk PC-DOS Communications Software Users Manual	424410836-001 420040416-001
	MOLE-HPC-IBM-CR	C Compiler for IBM	HPC C Compiler Users Manual and Software Disk Assembler Software for IBM MOLE-HPC-IBM	424410883-001
	MOLE-HPC-VMS	Assembler, Loader, Librarian for VAX/VMS	HPC Software User's Manual and 9 Track Tape	424410836-001
	MOLE-HPC-VMS-C	C Compiler for VAX/VMS	HPC Software User's Manual and 9 Track Tape (Includes Assembler)	424410883-001
	424410897-001	Users Manual		424410897-001

## Development Support (Continued)

### FACTORY APPLICATIONS SUPPORT

Dial-A-Helper also provides immediate factory applications support. If a user is having difficulty in operating a MOLE, he

can leave messages on our electronic bulletin board, which we will respond to, or under extraordinary circumstances, he can arrange for us to actually take control of his system via modem for debugging purposes.

Voice: (408) 721-5582

Modem: (408) 739-1162

Baud: 300 or 1200 baud

Set-Up: Length: 8-Bit

Parity: None

Stop Bit: 1

Operation: 24 Hrs. 7 Days

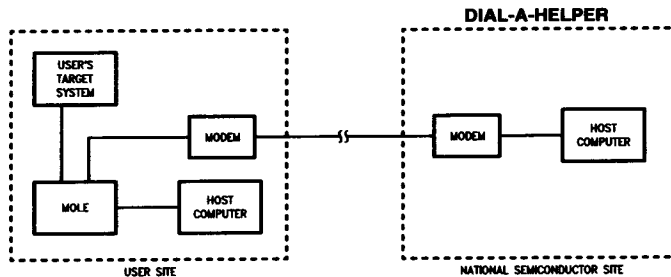

TL/DD/9682-37

## Part Selection

The HPC family includes devices with many different options and configurations to meet various application needs. The number HPC16164 has been generically used throughout this datasheet to represent the whole family of parts. The following chart explains how to order various options available when ordering HPC family members.

**Note:** All options may not currently be available.

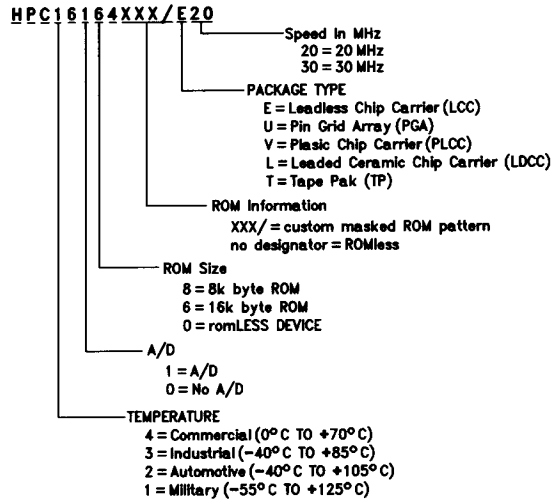

TL/DD/9682-33

**FIGURE 8. HPC Family Part Numbering Scheme**

### Examples

- HPC46104E20 — ROMless, Commercial temp. (0°C to 70°C), LCC
- HPC16164XXX/U20 — 16k masked ROM, Military temp. (-55°C to +125°C), PGA
- HPC26104XXX/V20 — ROMless, Automotive temp. (-40°C to +105°C), PLCC

**Physical Dimensions** inches (millimeters)

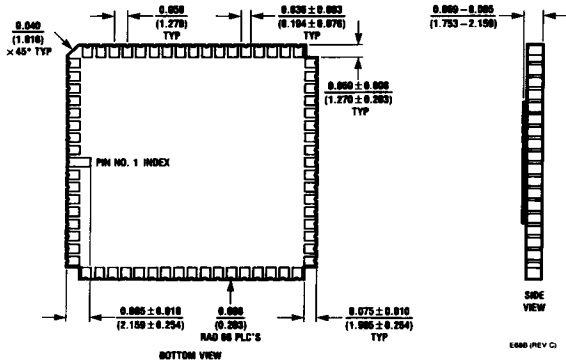
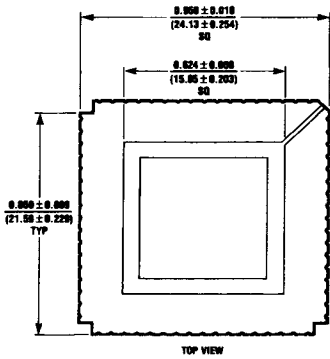

**Leadless Chip Carrier (E)**  
**Order Number HPC16164E**  
**NS Package Number E68B**

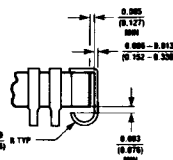
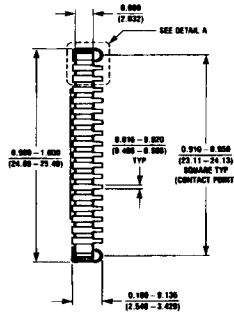
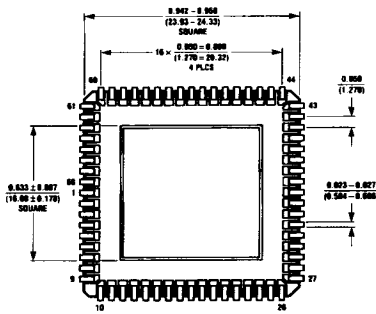

DETAIL A  
 SCALE: 10x

**Order Number HPC16164EL**  
**NS Package Number EL68A**



**Physical Dimensions** inches (millimeters) (Continued)

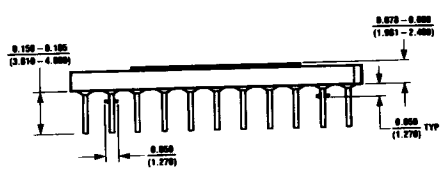
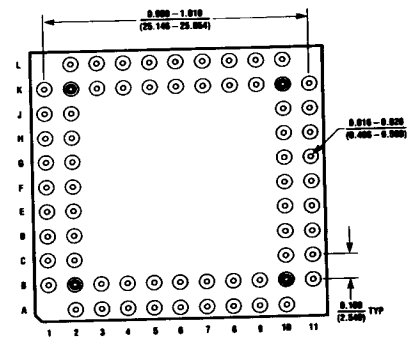
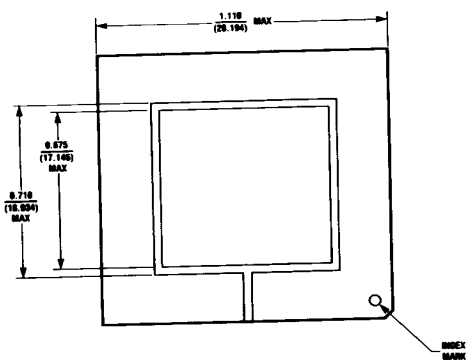

**Pin Grid Array Package (U)**  
**Order Number HPC16164U**  
**NS Package Number U68C**

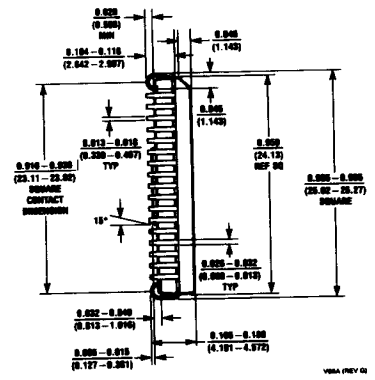
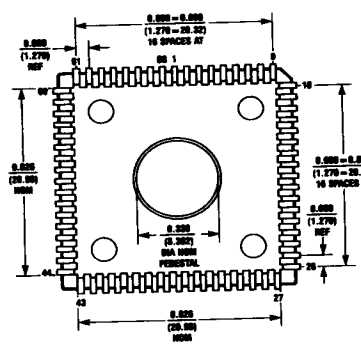

**Plastic Leaded Chip Carrier (V)**  
**Order Number HPC16164V**  
**NS Package Number V68A**

HPC16164/26164/36164/46164, 16104/26104/36104/46104, 16064/26064/36064/46064,  
HPC16004/26004/36004/46004 High-Performance microControllers with A/D

**Physical Dimensions** inches (millimeters) (Continued)

Lit. # 104385

**LIFE SUPPORT POLICY**

NATIONAL'S PRODUCTS ARE NOT AUTHORIZED FOR USE AS CRITICAL COMPONENTS IN LIFE SUPPORT DEVICES OR SYSTEMS WITHOUT THE EXPRESS WRITTEN APPROVAL OF THE PRESIDENT OF NATIONAL SEMICONDUCTOR CORPORATION. As used herein:

1. Life support devices or systems are devices or systems which, (a) are intended for surgical implant into the body, or (b) support or sustain life, and whose failure to perform, when properly used in accordance with instructions for use provided in the labeling, can be reasonably expected to result in a significant injury to the user.
2. A critical component is any component of a life support device or system whose failure to perform can be reasonably expected to cause the failure of the life support device or system, or to affect its safety or effectiveness.



National Semiconductor Corporation  
2900 Semiconductor Drive  
P.O. Box 58090  
Santa Clara, CA 95052-9090  
Tel: (408) 721-5000  
TWX: (910) 339-9240

National Semiconductor GmbH  
Westendstrasse 193-195  
D-8000 Munchen 21  
West Germany  
Tel: (089) 5 70 95 01  
Telex: 522772

NS Japan Ltd.  
Sannaido Bldg. 5F  
4-15 Nishi Shinjuku  
Shinjuku-Ku,  
Tokyo 160, Japan  
Tel: 3-299-7001  
FAX: 3-299-7000

National Semiconductor Hong Kong Ltd.  
Southeast Asia Marketing  
Austin Tower, 4th Floor  
22-23A Austin Avenue  
Tsimshatsui, Kowloon, H.K.  
Tel: 3-7231290, 3-7243645  
Cable: NSSEAMKTG  
Telex: 52998 NSSEA HX

National Semicondutores Do Brasil Ltda.  
Av. Eng. Faria Lima, 830  
8 Andar  
01452 Sao Paulo, SP, Brasil  
Tel: (55/11) 212-5096  
Telex: 301-1131931 NSBR BR

National Semiconductor (Australia) PTY, Ltd.  
21/3 High Street  
Bayswater, Victoria 3153  
Australia  
Tel: (03) 729-6333  
Telex: AA32096

National does not assume any responsibility for use of any circuitry described, no circuit patent licenses are implied and National reserves the right at any time witho

42

013338 X - X