

SHARP CORPORATION  
SPECIFICATION FOR LCD DISPLAY MONITOR

GENERAL SPECIFICATION

MODEL :6L-U7WE

1. Input signal	NTSC Video signal Analog RGB signal (Horizontal scan rate 15.734 kHz)
2. Power voltage	DC 9.0 V
3. Power consumption	6.7 W at DC 9.0V
4. Viewing area Dimension	Diagonal 146.1 mm 5.8 “ Width 127.2 mm Height 71.8 mm
5. Dimensions (Approx.)	145 (W) x 89 (H) x 20.5 (D) mm
6. Weight (Approx.)	325g (approx.)
7. LCD Display Panel	TFT Active Matrix 280,800 Dots ( 1,200 H x 234 V) Stripe arrangement
8. Back light	Cold Cathode Fluorescent Tube C-Shaped Lamp Edge Lighting System
9. Semiconductors (except LCD panel)	ICs 8 pcs. Transistors 15 pcs. Diodes 6 pcs.
10. Standards Safety standards	UL 1492 under considering

12. External terminal  
A Connector

Pin No.	Symbol	Function	Remark
A1	SYNC	Composite Sync. input	Negative polarity
A2	SYNC GND	C-Sync GND	
A3	VIDEO	Video Input	NTSC Composite video
A4	Video GND		
A5	COLOR	Color adjustment signal	
A6	TINT	Tint adjustment signal	
A7	BRIGHT	Brightness adjustment signal	
A8	N.C.		
A9	Wide Control 1	Wide mode control Input 1	Note 2
A10	Wide Control 2	Wide mode control Input 2	Note 2
A11	SIGN VCC	Power input for video circuit	9V
A12	SIGN GND	Video circuit GND	
A13	Wide Control 3	Wide mode control Input 3	Note 2
A14	N.C.		
A15	N.C.		
A16	SI	Superimpose mode Selection	Note 1
A17	5.3 V OUT	+ 5.3V Output	
A18	DIMMER	Dimming adjustment signal	
A19	R	Red Signal input	Analog RGB signal
A20	G	Green Signal Input	Analog RGB signal
A21	B	Blue Signal Input	Analog RGB signal
A22	RGB GND	Analog RGB GND	
A23	STH	Horizontal Sync. Output	C-MOS level
A24	STV	Vertical Sync. Output	C-MOS level
A25	YS	RGB / Video Selection	High : RGB Low : Video
A26	UD	Reverse Image Selection	High : Normal Low : Reverse
A27	BL GND	Inverter circuit GND	
A28	BL GND	Inverter circuit GND	
A29	BL VCC	+9 V Input (for Inverter)	
A30	BL VCC	+9 V Input (for Inverter)	

Connector manufacture  
Connector name

Molex  
52271-3090  
1.0 mm pitch 30 poles  
Contact side : Lower

(Note1)  
( A16 )

Normal mode  
Open

Superimpose Mode  
GND

(Note2)

Screen Mode	( A9 )	( A10 )	( A13 )	Reference
Full Screen Mode	High	High	High	
Wide 1 Mode	High	Low	High	
Normal Mode	Low	High	High	
Cinema Mode	Low	Low	High	
Wide 2 Mode	High	High	Low	
Test Mode	High	Low	Low	Don't use
Test Mode	Low	High	Low	Don't use
Test Mode	Low	Low	Low	Don't use

- Full Screen Mode                      Wide mode ( Fix expand rate )
- Wide 1 Mode                              Wide Mode
- Normal Mode                              4:3 Display
- Cinema Mode                              Extend in Vertical direction    (Video Source 16:9 letter box)
- Wide 2 Mode                              Wide Model + extend in vertical direction

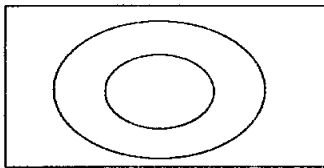

Full Screen Mode

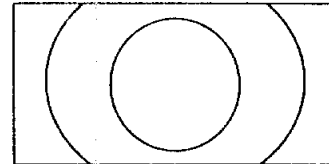

Cinema Mode

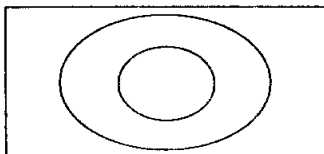

Wide 1 Mode

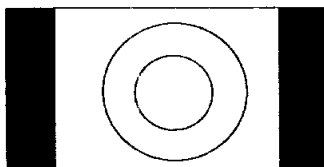

Normal Mode

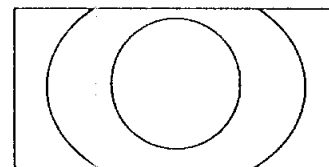

Wide 2 Mode

# SHARP CORPORATION

## ENGINEERING SPECIFICATION

MODEL : 6L-U7WE

1. General	Nominal	Limit
1) Power Voltage	DC 9.0 V	8.5 V to 9.5 V
2) Operating temperature Range	25°C	-10°C to 60°C
3) Storage temperature Range		-30°C to 85°C
4) Power Consumption (DC 12.0 V Nominal)		<u>6.7 W ± 15 %</u>
2. Video output characteristics		
1) Video output ( at tint, color and brightness control center position with standard half color bars signal)		3.3 V p-p±0.7Vpp
2) Video fidelity ( at 100kHz standard , NTSC video signal )		
1 MHz	± 1.0 dB	
2 MHz	- 0.6 dB	
3 MHz	- 14.0 dB	
3.58MHz	- 32 dB	
3. Picture quality		
1) Resolution ( ITC pattern , NTSC video signal )		
Horizontal center	220 lines	200 lines min.
corner	220	200
Vertical center	190	170
corner	190	170
2) Step response		
rising edge time		500 ns max.
pre shoot		35 % max.
over shoot		20 % max.

#### 4. Chroma Section

1) Color control range			3 dB min.
2) Tint control range ( for information only )			
To green	30°		12° min.
To purple	30°		12° min.
3) Tint stability ( for information only )			
Tint drift	3°		12° max.
Tint shift	3°		12° max.
4) ACC characteristicsACC ( at chroma output level -6 dB )			0 dB
5) Color killer			
	-27dB		-18 dB max.

#### 5. Liquid crystal display

##### 1) Viewing area Dimension

Diagonal	146.1mm	5.8"
Width	127.2mm	
Height	71.8mm	

##### 2) Number of pixels

93,600pixels (280,800dots)

##### 3) Pitch of dots

Horiz. 106 μm

Verti. 307 μm

##### 4) Pixels pattern

RGB Stripe arrangement

##### 5) Contrast (best viewing position)

1:60 min.

##### 6) Response time( at 25 °C)

60 msec max.

##### 7) Viewing direction

6 o'clock / 12 o'clock swichable

##### 8) Viewing angle (at contrast 1:5 min.) 12 o'clock

Left / Right 60°/ 60° min.

Up / Down 60° / 35° min.

##### 9) Brightness ( for information only )

at 25 °C, after 30 minutes warming up, at DC 9V, at 100% white video signal, at no dimming mode ,brightness adj. max. )

320 cd/m<sup>2</sup> 200 cd/m<sup>2</sup> min.

##### 10) Dimming Range ( for information only )

100 ~ 15 %

6. Input signal requirement

1) Analog RGB signal

a. Video signal

Input level	0.7 V p-p	0.7 V p-p $\pm$ 20 %
Input impedance		75 $\Omega$ $\pm$ 30 %

b. Sync. Signal ( A1 terminal )

Input level	TTL level	L 0 - 0.8 V H 3.5 - 5.0 V
Input impedance		9 k $\Omega$ $\pm$ 30 %
Horizontal scan rate		15.73 kHz $\pm$ 400 Hz
Vertical scan rate		60 $\pm$ 5 Hz

c. Video signal at Superimpose mode

input level 0.4 V p-p

When RGB signal is used to super impose text on composite video signal, RGB signal shall be smaller than 0.4V p-p

2) NTSC Composite Video signal ( standard signal : luminance order color bar signal with 100% white peak level )

Input level	1.0 V p-p	1.0 V p-p $\pm$ 0.2 V
Input impedance		75 $\Omega$ $\pm$ 10 %

3) Ys signal (A25 terminal)

input level		L : 0 ~ 0.8 V H : 3.5 ~ 5.3 V
input impedance		10 k $\Omega$ min.

4) Reverse image selection signal ( A26 terminal )

input level		L : 0 ~ 0.8 V H : 3.5 ~ 5.3 V
input impedance		10 k $\Omega$ min.

5) Superimpose signal (A20 terminal )

input level		L : 0 ~ 0.8 V H : 3.5 ~ 5.3 V
input impedance		10 k $\Omega$ min.

6) Wide mode control inputs

Terminal #	Terminal Symbol
A9	WIDE CONTROL 1
A10	WIDE CONTROL 2
A13	WIDE CONTROL 3

input level

L: 0 ~ 1.0 V

H: 3.5 ~ 5.3 V

input impedance

1M  $\Omega$  min.

7) Other input signals ( picture adjustments)

Terminal #	Terminal Symbol	Min.	Typ.	Max.
A18	DIMMER	2.0 V		4.6 V
A7	BRIGHT	2.1 V	2.5 V	4.8 V
A5	COLOR	0 V	3.0 V	4.8 V
A6	TINT	1.0 V	3.1 V	4.8 V

7. Output signals

1) + 5.0 V output ( A3 terminal)

Output voltage level

5.3V  $\pm$  10 %

Maximum output current

10 mA Max.

2) STH signal ( A23 terminal ), STV signal ( A24 terminal )

Output level

C-MOS level

Output current

$\pm$  20 mA

Signal polarity

Negative

9. Signal input timing(H-sync:micro second,V-sync:# of lines)

a) Video Mode

9.1 Nomad Mode

a) Horizontal display period

unit :  $\mu\text{s}$

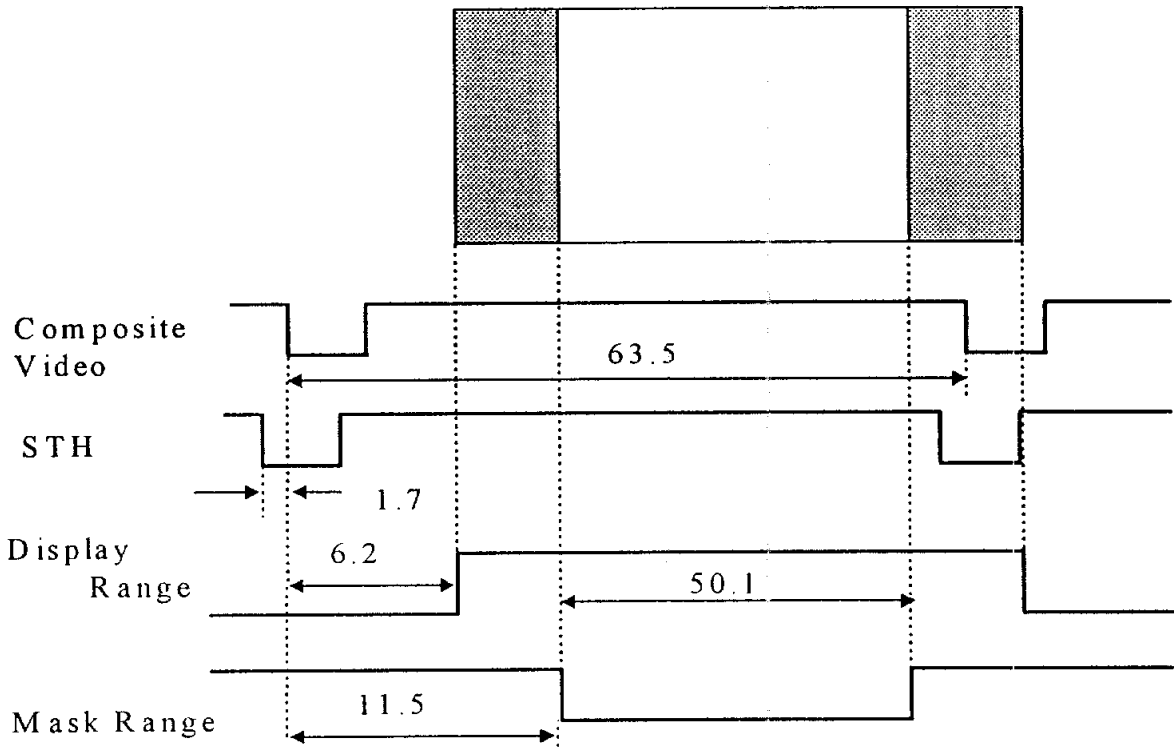

b) Vertical display period

unit : H line

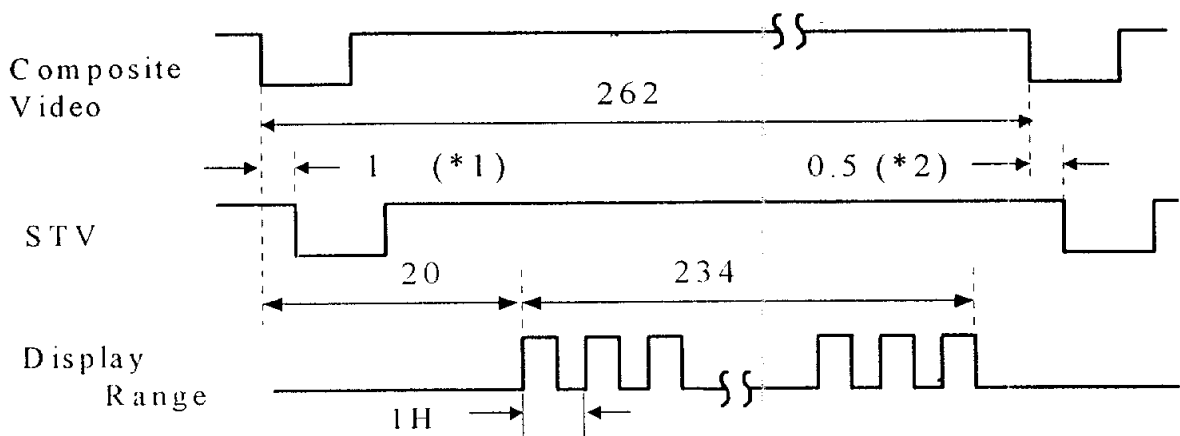

\* 1 : Vertical sync phase difference at Odd Field period

\* 2 : Vertical sync phase difference at Even Field period

## 9.2 Full Screen Mode

### a) Horizontal display period

unit :  $\mu\text{s}$

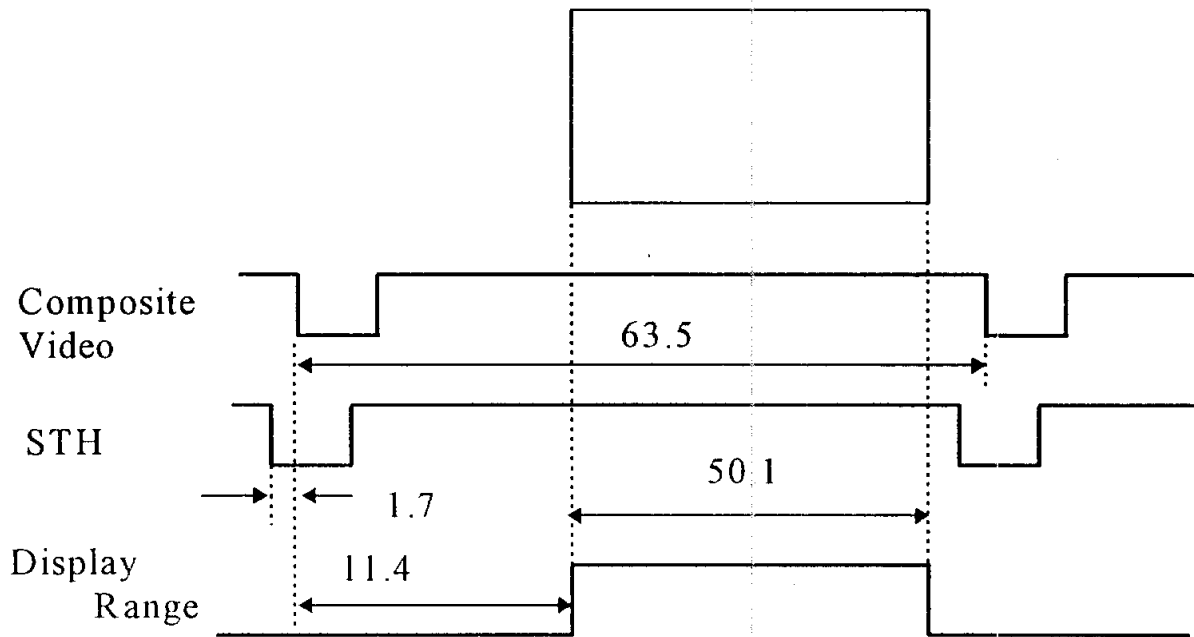

### b) Vertical display period

unit : H line

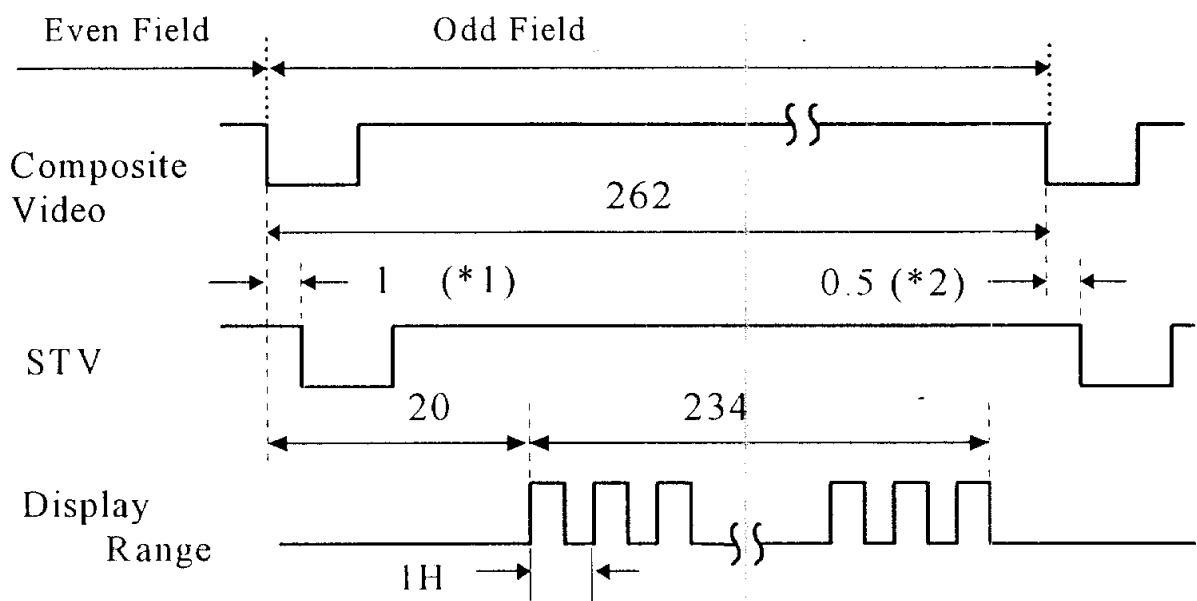

- \* 1 : Vertical sync phase difference at Odd Field period
- \* 2 : Vertical sync phase difference at Even Field period

### 9.3 Cinema Mode

a) Horizontal display period

unit :  $\mu\text{s}$

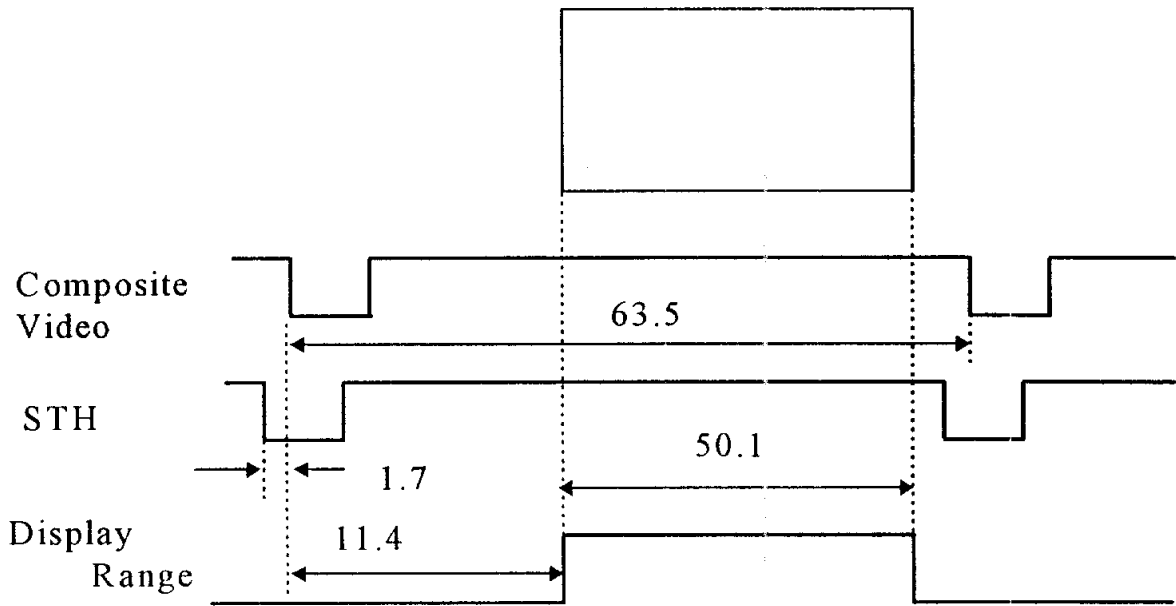

b) Vertical display period

unit : H line

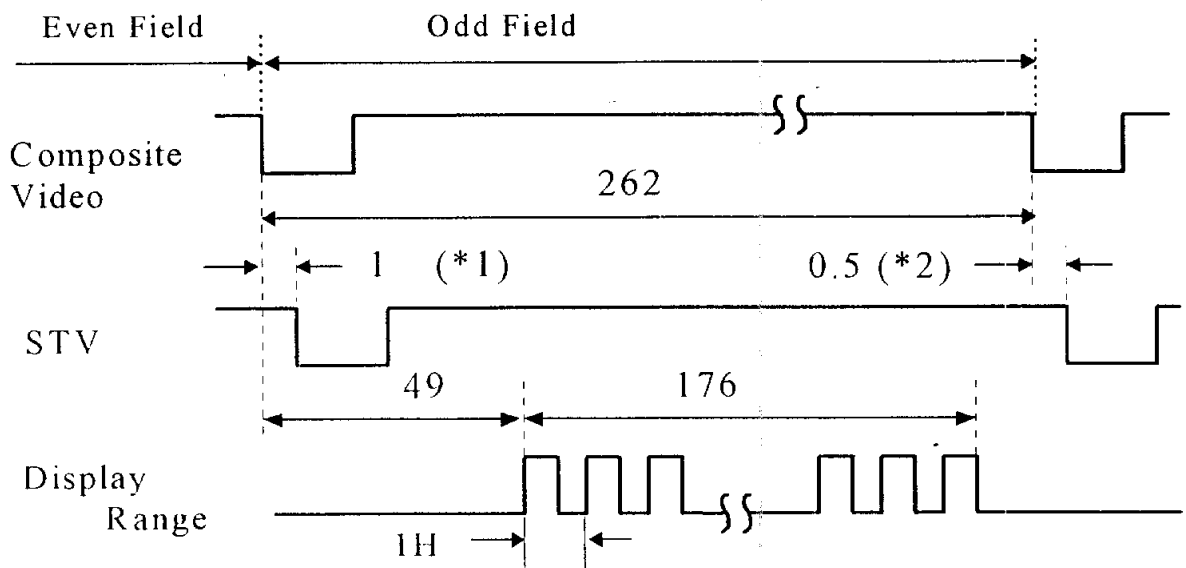

- \* 1 : Vertical sync phase difference at Odd Field period
- \* 2 : Vertical sync phase difference at Even Field period

## 9.4 Wide 1 Mode

a) Horizontal display period

unit :  $\mu\text{s}$

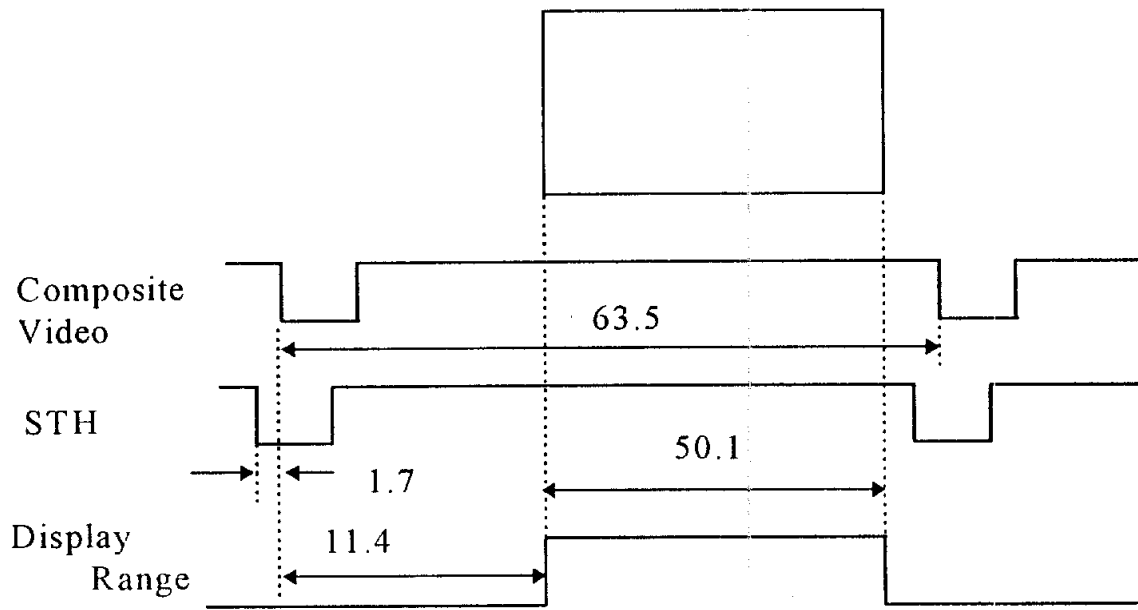

b) Vertical display period

unit : H line

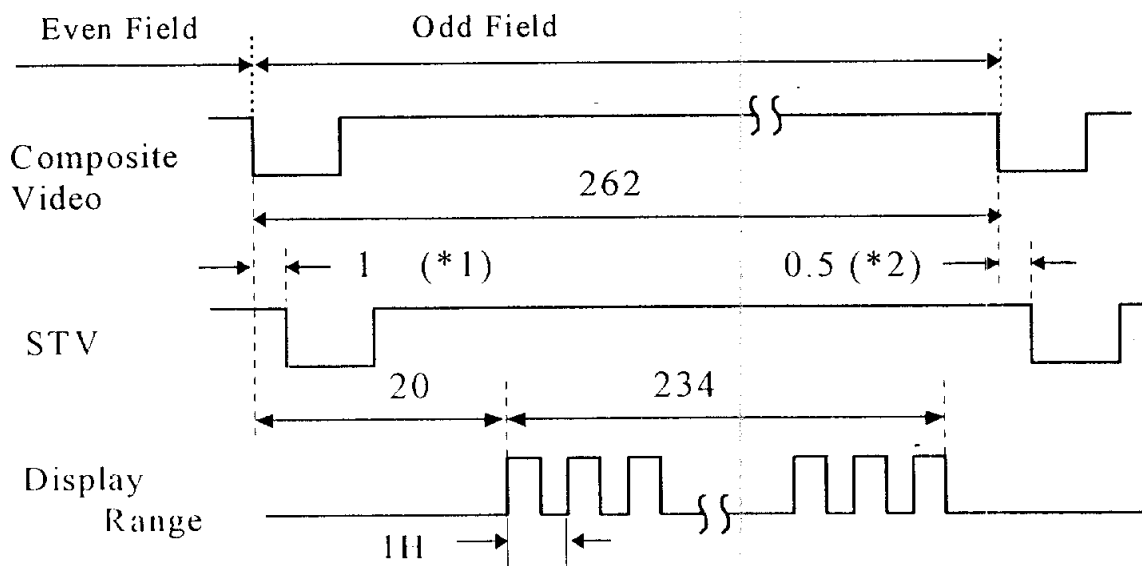

\* 1 : Vertical sync phase difference at Odd Field period

\* 2 : Vertical sync phase difference at Even Field period

## 9.5 Wide 2 Mode

### a) Horizontal display period

unit :  $\mu\text{s}$

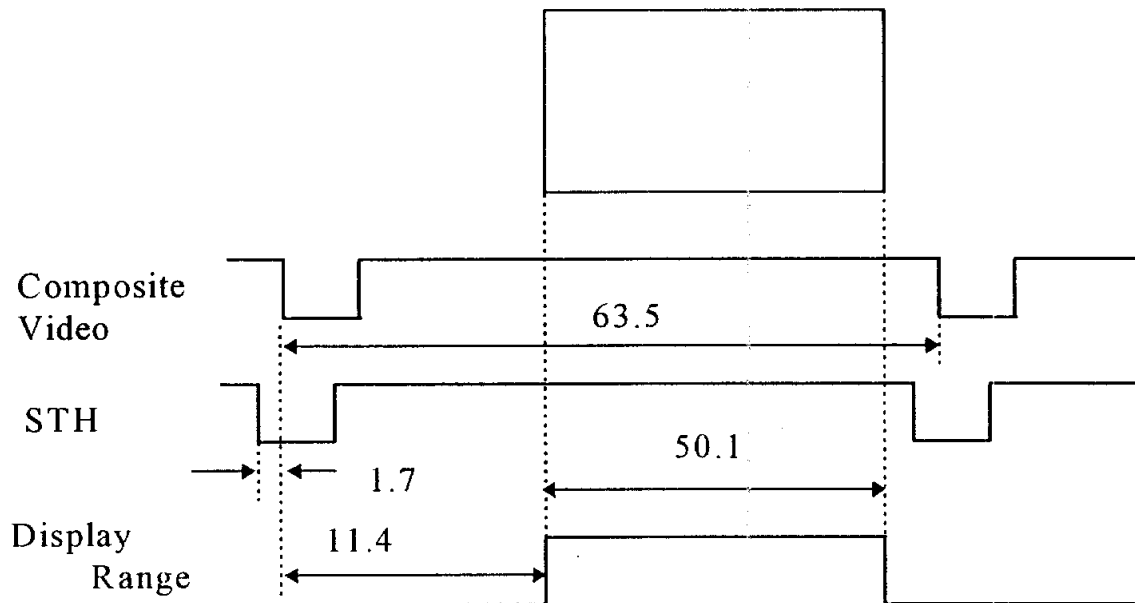

### b) Vertical display period

unit : H line

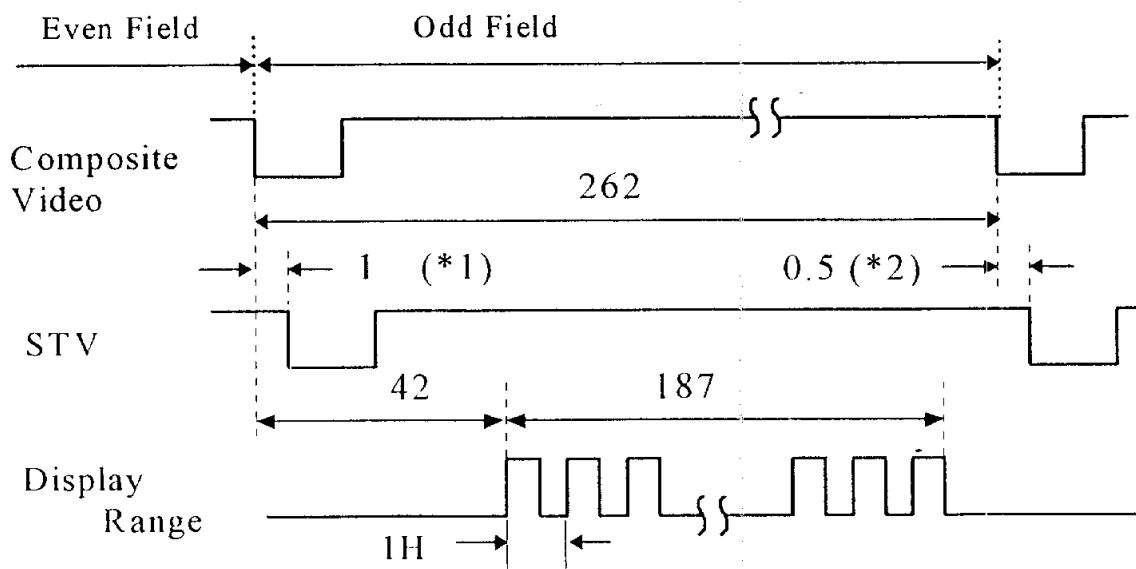

\* 1 : Vertical sync phase difference at Odd Field period

\* 2 : Vertical sync phase difference at Even Field period

b.) RGB Mode

- A full-screen image is obtained with the following timing:  
Screen mode : Full Screen mode

a) Horizontal display period

unit :  $\mu\text{s}$

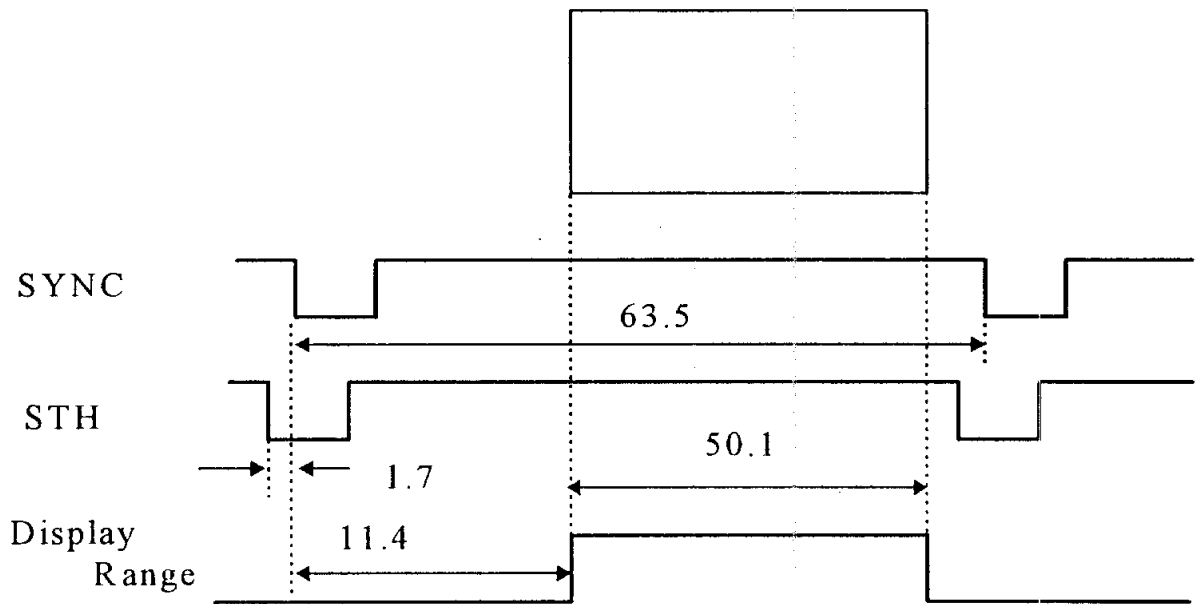

b) Vertical display period

unit : H line

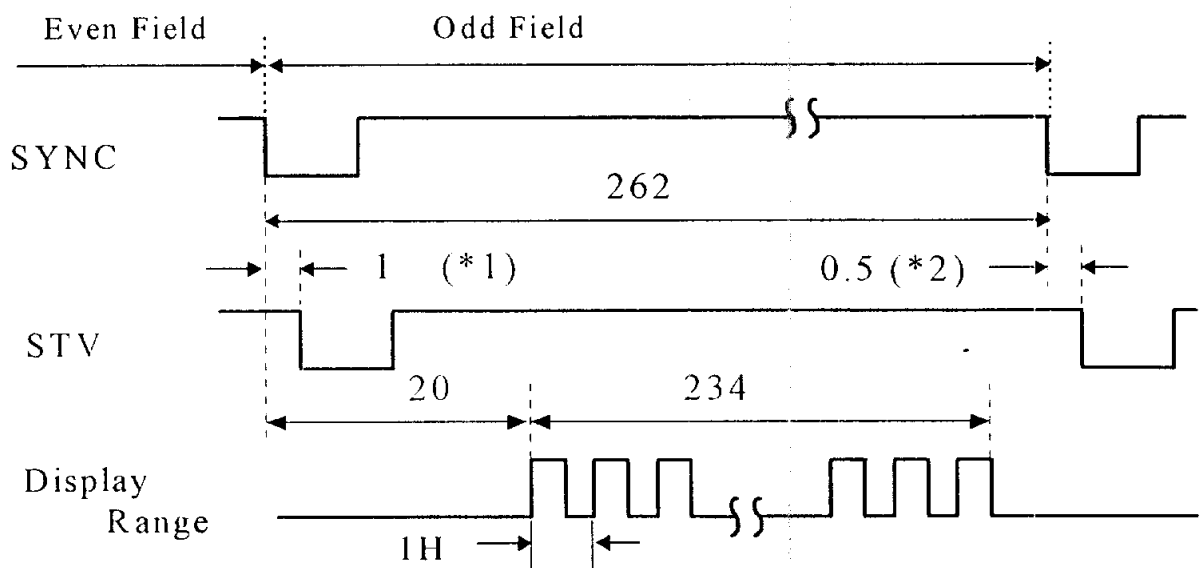

SYNC signal timing : Based on RS-170A

c.). Superimpose Mode

Screen mode : Full Screen mode

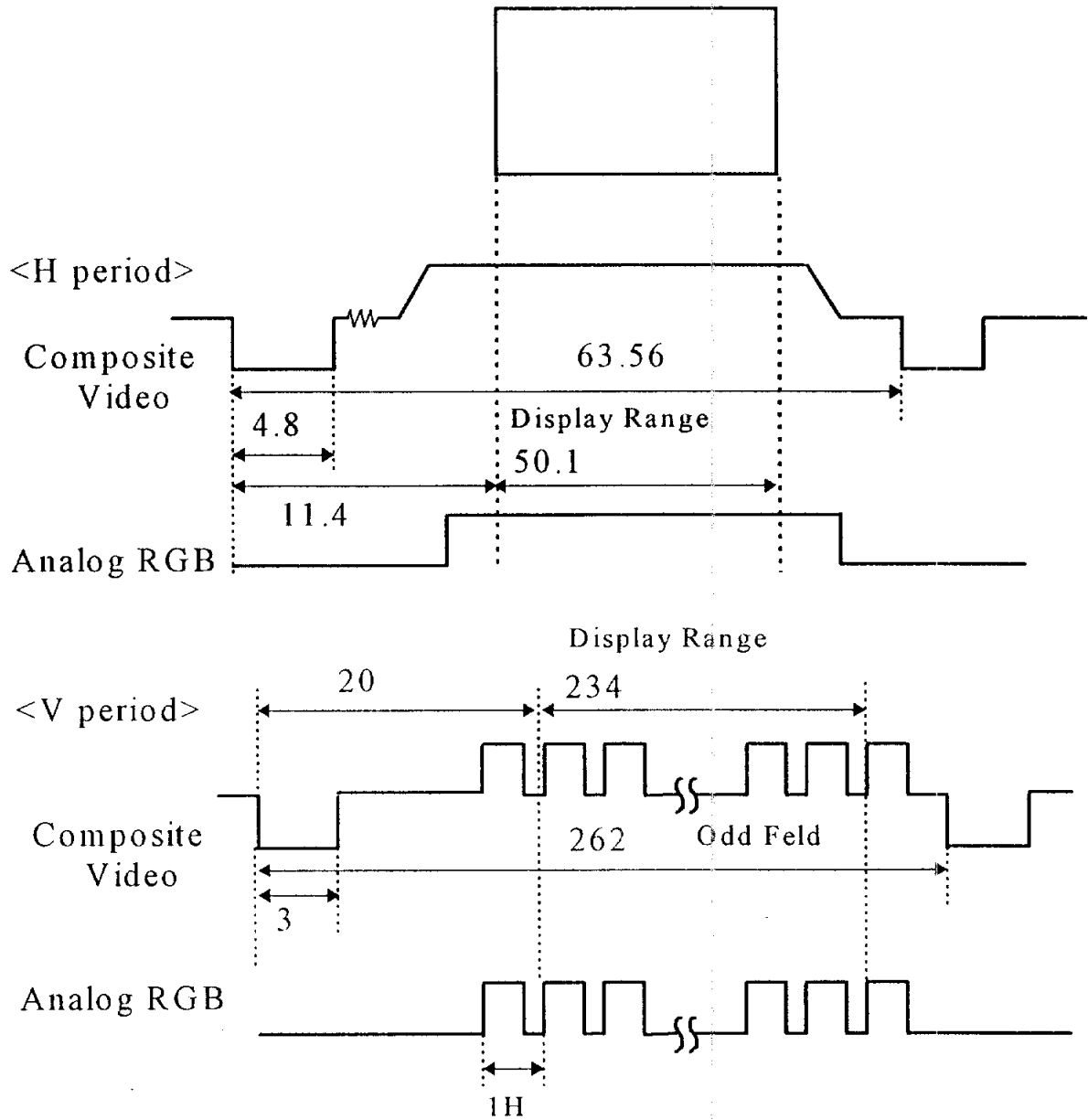

## RELIABILITY TEST

MODEL : 6L-U7WE

It is required that LCD chassis unit should be designed to comply with all the following reliability test.

1. Drop test

Drop off the carton, which includes 40 chassis inside, against the floor with 1 corner, 3 edges and 6 surfaces from the height of 50cm.

The floor should be flat surface with horizontal position and made of concrete, rock, steel plate or equivalent.

After drop test, the unit should have no safety hazard and operate as normal usage without any damage.

2. Vibration test

Conduct the following vibration test with the carton, which includes 20 chassis inside, and should operate as normal usage without any damage after this test.

Frequency(Hz)	:	5 to 50
1 cycle period	:	3 minutes(back and force)
Acceleration	:	1.0G each (X.Y.Z)
Securement	:	Banding
Time	:	Up/Down 60 minutes
		Forward/Back 15 minutes
		Right/Left 15 minutes

3. Pressure reduction test

Set up the unit in the pressure reduction chamber and reduce the air pressure gradually from the normal pressure to 510hPa(380mmHg) which is equivalent to 5,000m height. There should have no damage to turn on the unit with 10% increased power voltage for 30 minutes and repeat power on and off for 3 times quickly.

4. High temperature storage(without power)

Keep the unit in 85°C temperature chamber for 8 hours without power.

Take out the unit to make it normal temperature and make sure that the unit has no safety hazard and operate as normal usage without any damage.

5. Low temperature storage(without power)

Keep the unit in -30°C temperature chamber for 4 hours without power.

Take out the unit to make it normal temperature and make sure that the unit has no safety hazard and operate as normal usage without any damage.

Operate the unit in 40°C temperature and 90 thru 95% humidity chamber for 90 hours with  $\pm 10\%$  increased power.

Make sure that the unit has no safety hazard and operate as normal usage without any damage.

6. Humidity test(with power)
 

Operate the unit in 40°C temperature and 90 thru 95% humidity chamber for 90 hours with  $\pm 10\%$  increased power.

Make sure that the unit has no safety hazard and operate as normal usage without any damage.
7. High temperature test(with power)
 

Operate the unit for 8 ~16 hours with  $\pm 10\%$  increased power after keeping the unit in 60°C temperature chamber for 2 hours.

Make sure that the unit has no safety hazard and operate as normal usage without any damage.
8. Low temperature test(with power)
 

Operate the unit for 8 ~16 hours with  $\pm 10\%$  increased power after keeping the unit in -10°C temperature chamber for 2 hours.

Make sure that the unit has no safety hazard and operate as normal usage without any damage.
9. Thermal shock test
 

Keep the unit in the following temperature chamber without power.

Take out the unit to make it normal temperature and make sure that the unit has no safety hazard and operate as normal usage without any damage.

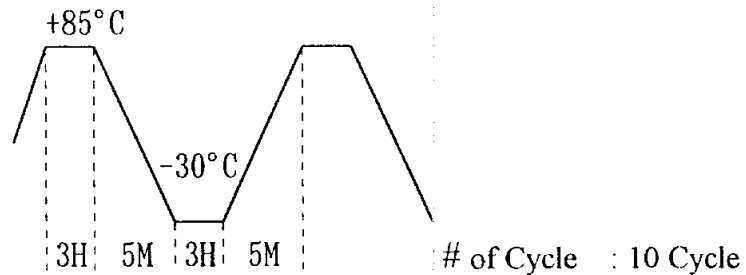

# SHARP

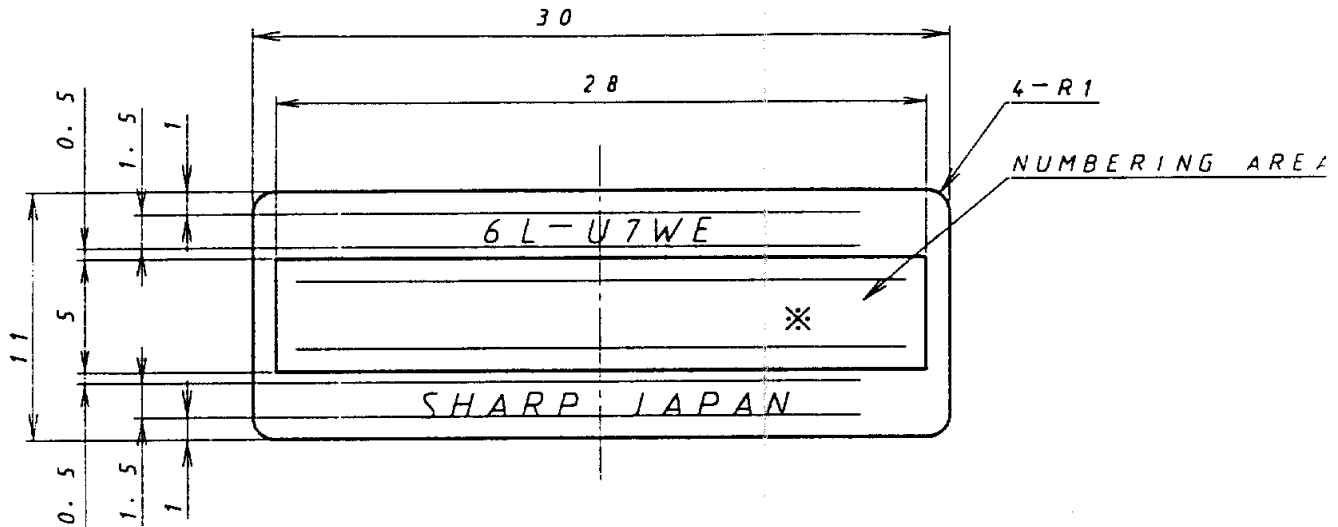

※ SERIAL NO.

9 DIGIT

EX. : 804311112

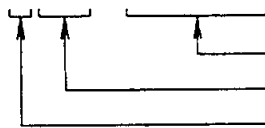

SEQUENTIAL NO. FROM 11112  
 PRODUCTION MONTH  
 PRODUCTION YEAR  
 (THE LAST DIGIT OF YEAR)

- SHCA
- SREC
- 主キット
- 品 種
- 生産業務
- 発 売
- 海 推
- デザイン
- 主 産
- 主 産
- 製品品質
- 名 管
- 資 材
- 工 装
- 原 管
- 技 術
- 設 計
- 配 布 先

名 称 NAME	部 品 コ ー ド PART CODE	△		
MODEL LABEL	T L A B M 4 0 0 8 C E Z Z	△		
材 質 MATERIAL	仕 上 FINISH	△		
PVC SHEET 804+ LAMINATE(PL)25μ ADHESIVE REAR-SIDE	SET-SOLID PRINTING(BLACK) (EXCEPT CHARACTER. NUMBERING AREA)	△		
設計 DESIGNER	製 図 DRAWN	△	年 月 日 DATE	訂 正 記 事 REVISIONS
検 査 CHECKED	承認 APPROVED	△	適用機種 MODEL	設 通 設 成 日 付 DATE
Murayama	2th ENGINEERING Gr. TV1 DIVISION SHARP CORPORATION	△	#44126	1997.08.



OUTGOING INSPECTION STANDARD  
FOR  
MODEL:6L-U7WE

JAN., 7, 1998

This inspection standard shall be applied for the outgoing inspection effected at the factory of Sharp Corporation on 5.8 inch Color LCD Display Model 6L-U7WE to be supplied to Hyundai Electronics Industries Co.,Ltd.

1. Inspection Method:

Inspection method is based on sampling inspection.

(1)Inspection System:

Sampling inspection based on ISO-2859 Normal inspection, single sampling, level II.

(2)Lot Size:

Quantity per shipment per model

(3)Acceptable Quality Level(AQL):

The AQL's are established for major and minor and defectives separately as follows:

- i)Major defectives:AQL 0.4
- ii)Minor defectives:AQL 1.0

(4)Classification of Defective:

Defective are classified as a major defective and a minor defective according to their seriousness.

i)Major defectives:

A major defective contains one or more major defects and may also contain defects. A major defect is a defect that is likely to result in failure, or to reduce materially the usability of the product for its intended purpose.

ii)Minor defectives:

A minor defective contains one or more minor defects but contains no major defect. A minor defect is a defect that is not likely to reduce materially the usability of the product for its intended purpose, or is a departure from established standards having little bearing on the effective use or operation of the product.

Detail as per the separate table titled "Classification of Defectives", attached.

(5) Judgement of Inspection Result:

If the number of defective sets in the lot is equal to or less than the applicable acceptance number, the lot shall be accepted. On the other hand, if the number of defective set is equal to or more than the applicable rejection number, the lot shall be rejected.

i) Accepted lot: Shipment released.

ii) Rejected lot: 100% re-inspection of the lot and necessary corrective measures shall made. Then, the same outgoing inspection shall be made to the lot again.

- 2 . Items to be Inspected :
- 1-appearance
  - 2-Performance
  - 3-Display

3 . Inspection Condition:

Unless otherwise stipulated for each inspection, all inspections shall be made with the following inspection conditions.

i) Power Supply : DC 9.0V

ii) Environment : Normal temperature and normal humidity within a room.

001102

5.8 inches Multi-color LCD Display  
Model 6L-U7WE  
Defective Classifications Exterior

JAN., 7, 1998

1. Appearance

NO	Item	Requirements	Judgement Reference	Defective Class			Remarks
				Fatal	Major	Minor	
1.1	•Carton box	•The carton box shall be the one designed exclusively for the pertinent product, and shall be free from damage, incomplete bonding, soil, or any other visual flaws.	•Torn damage •Incomplete bonding •Printed information error			○  ○  ○	
1.2	•Serial No. •Label	•Shall have no error, and be free from any visual deficiency.	•Missing label •Error information •Illegible due to surface soil or dirt. •Notable skew or displacement from the normal position.		○ ○	○  ○	
1.3	•External terminal, A connector	•Shall pose no problem in normal connections.	•Proper connection is difficult or disabled.		○		
1.4	•Screw fastening	•There shall be no loose screws or those with damaged screw threads.	•Loose screws •Screws with damaged screw threads		○ ○	○	

2. Performance

NO	Item	Requirements	Judgement Reference	Defective Class			Remarks
				Fatal	Major	Minor	
2.1	Picture	•No appreciable Problem shall be observed in picture quality, focus, and others.	•Poor picture quality, poor focus, etc.		○		
2.2	Brightness	•Center areas: less than 200cd/m <sup>2</sup>	•Significantly dark			○	
2.3	Synchronization	•Both horizontal and vertical synchronization shall be normal.	•Off-synchronization(V jitter, pull-in, sustain, or other faults)		○		
2.4	R•G•B Input	•Shall function normally.	•Defective function.		○		
2.5	Shock noise	•Shall produce no visual or audible noise or any other malfunction when the unit sustained physical shock or vibration.	•Noise or malfunction.		○		
2.6	Unusual noise	•No unusual noise shall be heard from the unit.	•Noise beyond usability. •Annoying but within usability.		○	○	
2.7	Power consumption	•DC 9.0V 6.7W±15%	•Power consumption outside the specified		○		

### 3.Display

#### 3-1.Classification of defect

##### a)Major defect

###### •Function defect

Abnormal operation including distinct R,G,B line defects and or white line defect.

##### b)Minor defect

- ① Bright dots
- ② Display non-uniformity
- ③ Vertical stripes
- ④ An afterimage
- ⑤ Extraneous substances
- ⑥ Scratches
- ⑦ Dents
- ⑧ Current dissipation

#### 3-2.Pixel Failures

##### [Inspection Condition]

###### •Visual inspection

Viewing distance ... 350±50mm  
Ambient illumination ... 100~150Lux  
Ambient temperature ... 20~25℃

###### •Viewing angle ...

The surface of the MODULE and the eyes of the inspector shall be 90 degrees.

##### [Standards(Acceptable)]

###### 1)Bright dots(Red,Green)

	Zone Total
Red	3
Green	2

###### 2)Bright dots(Red,Green,Blue) and black dots

	Zone Total
Bright and black dots Total	10

##### NOTE:

###### a)Bright dots

- Count : Visible with a 5% Transparency of filter
- No count : Not visible with a 5% Transparency of filter

###### b)Scratches on the color filter

- Count : Visible over the half of a dot
- No count : Visible under the half of a dot

c)Scratches on the Cr. mask

- Count : Visible over 50  $\mu\text{m}\phi$
- No.count : Visible under 50  $\mu\text{m}\phi$

e)Defect distance

- Bright dots : 5mm Min.
- Black dots : 5mm Min.(Join. 2Max.)

### 3-3.Display non-uniformity

There should be no distinct non-uniformity visible through 1% transparency of filter.

- Viewing distance ... 350 $\pm$ 50mm
- Ambient illumination ... 100~150Lux
- Ambient temperature ... 20~25 $^{\circ}\text{C}$
- Viewing angle ...

The surface of the MODULE and the eyes of the inspector shall be 90 degrees.

### 3-4.Vertical stripes

Contrast unevenness on alternate source lines.

### 3-5.An afterimage(Acceptable level)

After displaying same pattern for 5 seconds afterimage disappears within 10 seconds.

### 3-6.External

Quantities=N,Average Diameter=D(mm),Length=L(mm)

Items to be inspected		Inspection standards (Acceptable level)
Extraneous substances	Black spots	Black spots which appears when operating $0.5 > D \quad N \leq 2$
	Nap	Nap which appears when operating $3.0 > L \quad N \leq 2$
Scratches		Scratches on the polarizer $10.0 > L \quad N \leq 3$
Dent		Dent on the polarizer $0.5 > D \quad N \leq 3$

NOTE:The external visual inspection

The inspection shall be conducted by using a single 20W fluorescent lamp for illumination and the distance between the MODULE and the inspector shall be 35cm or more.

## 6L-U7WE Electrical Interface Requirements

The following describes electrical requirements and precautions for the 6L-U7WE LCD Module.

### 1. Using Composite Video Input

- Use connector pins A3 and A4 ( GND ) for composite video input.
- Set pin A19 ( Ys signal ) to Low ( GND ) level .

### 2. Using Analog RGB Inputs

- Use connector pins A19 - A22, A1, and A2 for analog RGB input.
- For horizontal and vertical synchronization, apply a composite H/V sync. signal (Negative polarity video signal level) to pin A1.  
When separate H. and V. synchronization signals are desired, consult us.
- A high level ( 5V ) signal should be applied to the Ys signal input ( pin A25 ).

### 3. Using Superimposed Video Signals

- The composite and RGB video signals should be synchronized with each other.
- Use connector pins A19 through A22 for RGB video inputs, and pins A3 and A4 for composite video inputs.
- Set pin A16 (S/I ON signal ) to Low (GND) level to make the composite synchronization signal active.
- RGB is selected when the Ys (pin A19) is set high.

### 4. Controlling Color, Tint, and Brightness (pins A5, A6, and A7)

- The following voltage ranges are typically recommended for color, Tint, and brightness control:

	Pin #	Center Voltage	Voltage range
Color	A5	3.0 V	0 - 4.8 V
Tint	A6	3.1 V	1.0 - 4.8 V
Brightness	A7	2.5 V	2.1 - 4.8 V

### 5. Dimming Control Voltage

- The voltage applied to pin A18 should range from 2.0 to 4.6V volts.  
(Maximum brightness is at 2.0V and minimum brightness at 4.6V [around 15% of the maximum brightness]).

CAUTION) Keep the voltage applied to pin A18 below 4.6V. Other wise the display may flash.

### 6. Fuse

- The following fuse is being applied as protective components.  
Please apply specified fuse for the safety in the case fuse is blew out.  
F751 ; protect for Lamp drive line.

Fuse type : Rated current 1.25A rms., Slow blow type  
manufacture name SOC Corporation  
type no. MT7- 1.25A

F701 ; protect for video circuit line.

Fuse type : Rated current 1A rms., Slow blow type

manufacture name SOC Corporation

type no. SSTC- 1A

## 7. Connector Pin Assignments

### External Connector

Connector	Pin	Assignment
	A1	C-Sync Input ( Analog RGB signal )
	A2	C-Sync GND
	A3	Video Input ( NTSC Composite video signal )
	A4	Video GND
	A5	Color adjustment signal
	A6	Tint adjustment signal
	A7	Brightness adjustment signal
	A8	N.C.
	A9	Wide Control 1 Input(Note4)
	A10	Wide Control 2 Input(Note4)
	A11	+9 V Input (for Signal Circuit)
	A12	GND (for Signal Circuit)
	A13	Wide Control 3 Input(Note4)
	A14	N.C.
	A15	N.C.
	A16	Super Impose (Note2)
	A17	+5V OUTPUT
	A18	Dimming adjustment signal
	A19	Red Signal Input ( Analog RGB signal )
	A20	Green Signal Input ( Analog RGB signal )
	A21	Blue Signal Input ( Analog RGB signal )
	A22	RGB GND
	A23	H-SYNC OUTPUT ( Internal horizontal sync. signal)
	A24	V-SYNC OUTPUT ( Internal Vertical sync. signal )
	A25	Ys Input (Note1)
	A26	Reverse (Note3)
	A27	GND (for Inverter)
	A28	GND (for Inverter)
	A29	+9 V Input (for Inverter)
	A30	+9 V Input (for Inverter)

Connector manufacture Molex

Connector name 52271-3090  
1.0 mm pitch 30 poles  
Contact side Lower

(Note1)	Video Mode	RGB Mode
( A25 )	GND	High Level

(Note2)	Normal	Superimpose Mode
( A16 )	Open	GND

(Note4)

Screen Mode	( A9 )	( A10 )	( A13 )	Reference
Full Screen Mode	High	High	High	
Wide 1 Mode	High	Low	High	
Normal Mode	Low	High	High	
Cinema Mode	Low	Low	High	
Wide 2 Mode	High	High	Low	
Test Mode	High	Low	Low	Don't use
Test Mode	Low	High	Low	Don't use
Test Mode	Low	Low	Low	Don't use

- Full Screen Mode      Wide mode ( Fix expand rate )
- Wide 1 Mode            Wide Mode
- Normal Mode            4:3 Display
- Cinema Mode            Extend in Vertical direction    (Video Source 16:9 letter box)
- Wide 2 Mode            Wide Model + extend in vertical direction

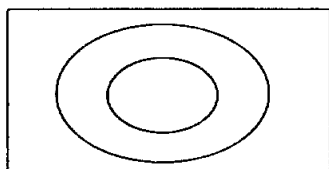

Full Screen Mode

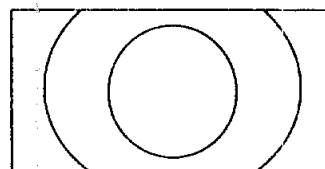

Cinema Mode

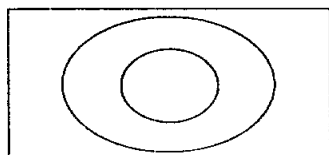

Wide 1 Mode

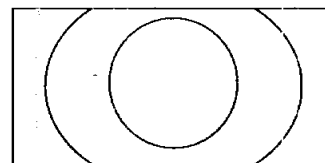

Wide 2 Mode

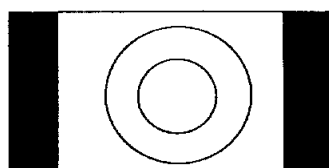

Normal Mode

## 8. Miscellaneous

### - Supply Input

The 6L-U7WE requires two separate power supply systems for signal processing (pins A12,A11) and the DC/AC inverter (A27,A28,A29,A30).

Separate voltage regulators should be used for the two power supply systems as follows:

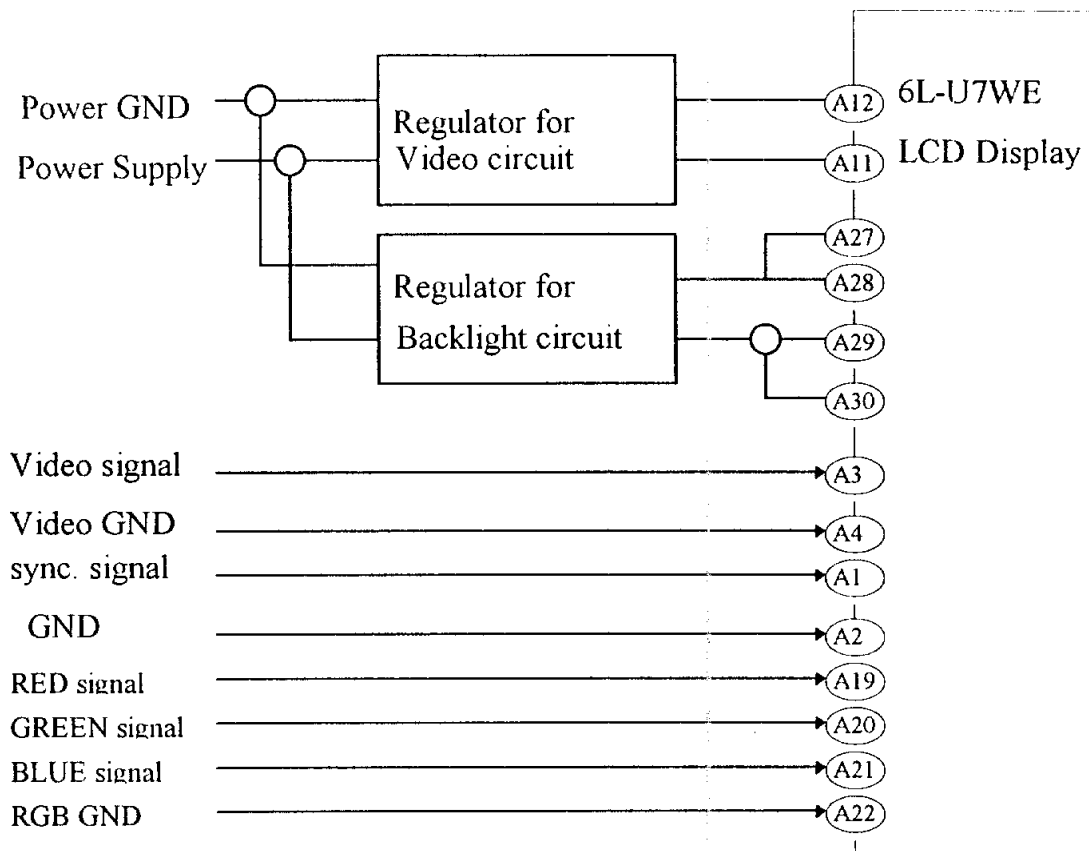

Connect the grounds for the two supply systems. Otherwise, display images may be disturbed by beat caused by supply ripple.

### - Input signal timing

Do not activate control signals before the supply voltages have stabilized for the signal processing and inverter circuits. Otherwise, the circuit may be damaged by latchup.

### - +5VDC output

The +5.3 VDC output at pin A3 may be used for brightness, color, tint, and dimmer adjustment. The current capacity is 10 mA max.

Note) The content of this information is subject to change without prior notice.

## 9. RECOMMENDED ADJUST CIRCUIT

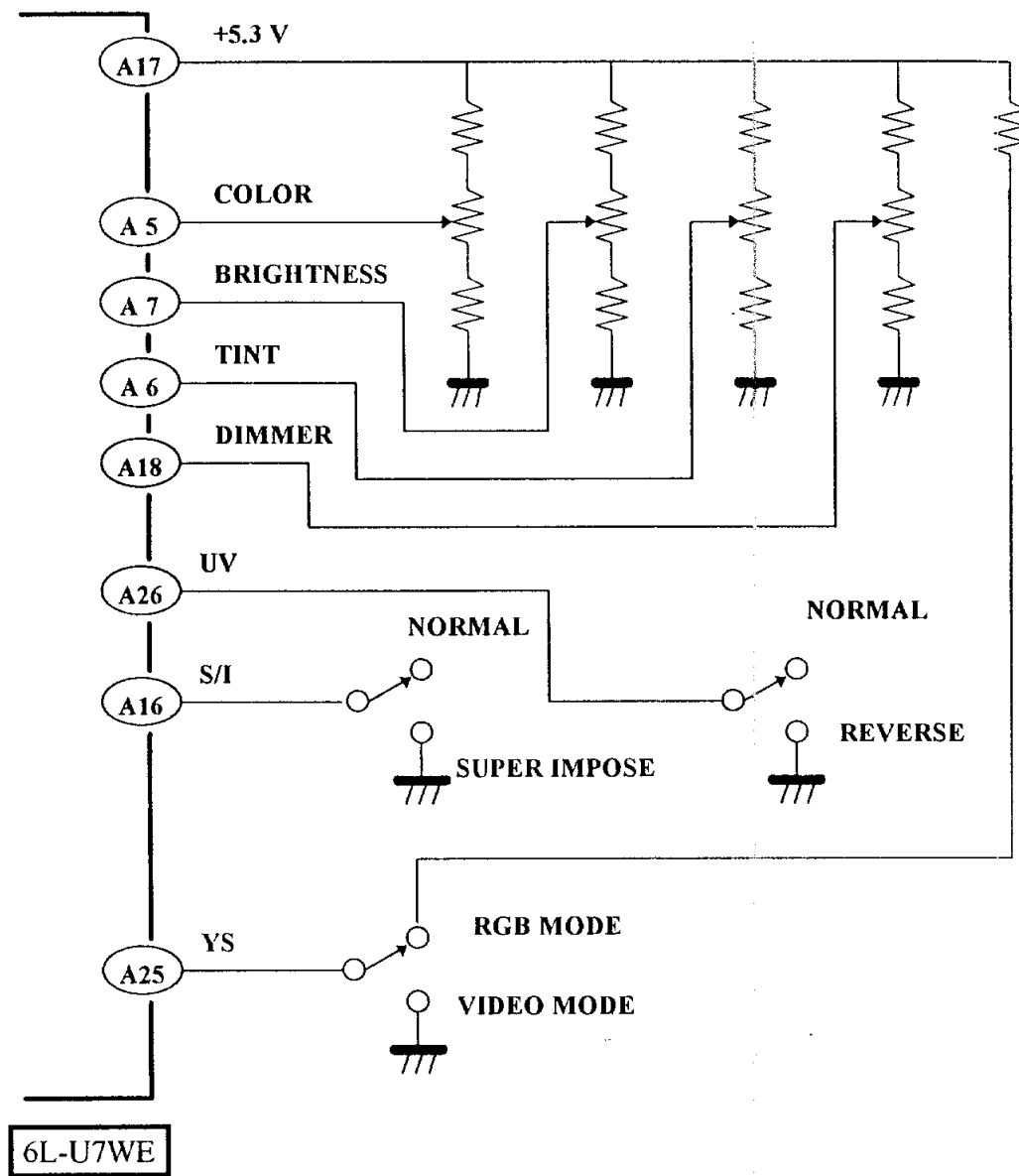

## 6L-U7WE HANDLING PRECAUTIONS

### 1. Cable Connection

- 1) Turn off the power to the LCD Display before connecting or disconnecting a cable.

### 2. Installation

- 1) For mounting , Please refer attached drawing .
- 2) When the LCD Monitor panel is to be installed directly on the equipment's surface, use the panel's metallic area for installation. If the panel surface is in direct contact with the equipment surface, the resulting stress may damage the panel or cause it to deteriorate.

### 3. Cautions for Installation

- 1) Handling the polarizing plate requires the utmost care, as it is easily damaged. To prevent possible damage or contamination, the plate's surface is protected with a protective film (lamination).

- 2) Cautions for removing the lamination

When removing the lamination from the polarizing plate surface, observe the following cautions. Pay special attention to static electricity.

#### A. Working Environment

To prevent damage from static electricity, the following working environment is recommended:

- The floor should have a conductive surface (conductive mat or paint) or more than  $1\text{M } \Omega$  resistance.
- The room should be isolated from the outdoor air, and have an adhesive mat at its entrance to clean shoes.
- The ambient atmosphere should be  $15$  to  $27\text{ }^{\circ}\text{C}$  ,  $50\%$  to  $70\%$  RH.
- The operator should wear conductive shoes, conductive work clothes, conductive gloves, and grounding wrist straps.

#### B. Work Procedure

- The deionizing blower should be oriented a little downward. Keep it within  $20\text{ cm}$  of the LCD panel. (see Fig. 1)

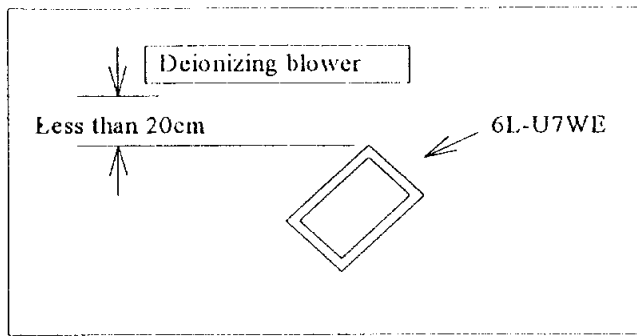

Fig. 1

- To protect the polarizing plate from possible damage, stick adhesive tape (plastic tape, etc.) on the corner of the lamination closest to the blower. (see Fig. 2)

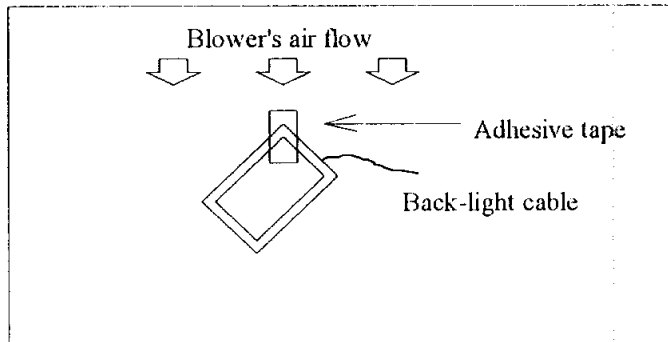

Fig. 2

- Gently and slowly remove the lamination while pulling the adhesive tape forward (take more than 5 seconds for this work).
  - After removing the lamination, immediately go to the next process before the panel gathers dust.
- 3) Cleaning dust off the polarizing plate surface
- Blow dust off the polarizing plate surface with an  $N_2$  blower with anti-static treatment. Use of an ionized air gun (from Hugle Electronics co. ) is recommended.
  - The polarizing plate surface is so sensitive that it should not be wiped with a cleaning cloth. If it gathers dust, use adhesive plastic tape to pick it up.
- 4) Contaminants on the shield casing or other metallic areas should be wiped off with a soft, dry cloth.
- 5) Water drips or fingerprints, if left on the panel surface for long time period, may cause discoloration or spots. They should be cleaned off as soon as possible.
- 6) The LCD panel is made of glass. Carefully protect it from hard jolts.

- 7) The LCD module uses CMOS ICs. Operators should properly ground themselves to prevent possible electrostatic damage.

#### 4. Precautions for Alignment

The LCD module and its driver board are adjusted as an integrated unit. If either the module or the driver board is replaced, readjustment will be required. Misalignment will do harm to performance and / or reliability.

#### 5. Miscellaneous

- 1) Do not leave the LCD panel in direct sunlight or strong ultraviolet light for very long.
- 2) At temperatures below the rated storage temperature, the liquid crystal inside the panel may be freeze and damage the cells. At temperatures above the rated storage temperature, the liquid crystal may irreversibly turn into an isotropic liquid. We strongly advise that the LCD panel be stored at close to normal room temperature.
- 3) If the LCD panel is cracked and the liquid within spills, take care not to swallow it. If your hands or clothing become stained with the liquid, immediately clean it off with soap and water.
- 4) Do not let the monitor constantly display a fixed image for long time, as it may leave an afterimage. In the worst case, the liquid crystal may suffer permanent burn-in damage.
- 5) Also observe general precautions for handling electronic parts.

#### 6. Insulation distance at high tension part.

The following components / pattern at lamp driving circuit have high voltage. (approx. 5K Vp-p). Therefore, please do not mount any metal within 3mm from these components / pattern.

- Line : T751 ~ C757 ~ P1

Note) The content of this section is subject to change without prior notice.



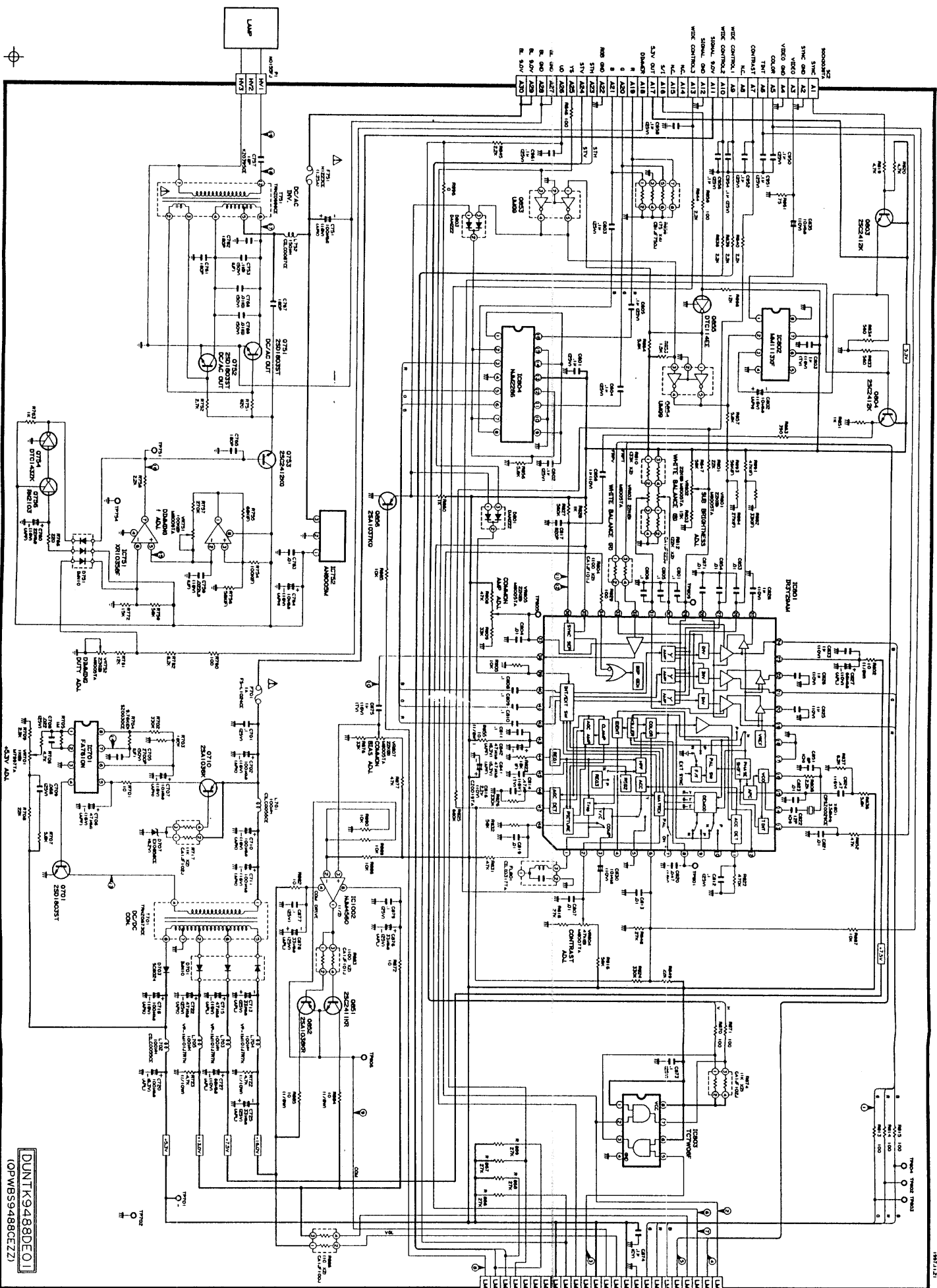

DUNT K9488DE01  
TOPWBS9488CEZ21

6L-UTWE BLOCK DIAGRAM

