

UNCONTROLLED DOCUMENT

PART NUMBER
SSP-24MDB153S12G

REV.
C

REV.	E.C.N. NUMBER AND REVISION COMMENTS	DATE
A	E.C.N. #10950.	1.30.03
B	E.C.N. #10993.	5.21.03
C	E.C.N. #10BRDR & REDRAWN.	7.16.04

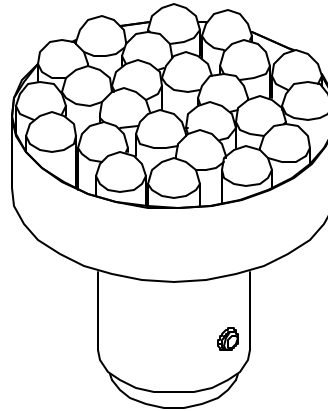
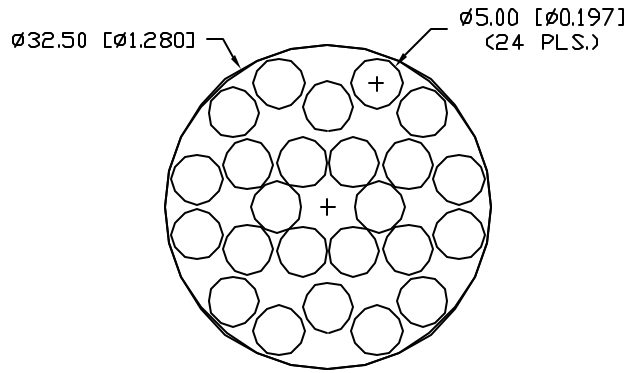

ELECTRO-OPTICAL CHARACTERISTICS $T_A=25^{\circ}\text{C}$ $V_f=12\text{V}$

PARAMETER	MIN	TYP	MAX	UNITS	TEST COND
PEAK WAVELENGTH		590		nm	
FORWARD VOLTAGE		12.0		V_f	
REVERSE VOLTAGE	5.0			V_r	$I_r=100\mu\text{A}$
AXIAL INTENSITY*		106,200/35,000		mcad	$V_f=12\text{V}$
VIEWING ANGLE		30		$2x$ theta	
EMITTED COLOR:	YELLOW				
EPOXY LENS FINISH:	WATER CLEAR				

* BRAKE/TAIL

LIMITS OF SAFE OPERATION AT 25°C

PARAMETER	MAX	UNITS
PEAK FORWARD VOLTAGE	14.0	V
STEADY CURRENT	140	mA
POWER DISSIPATION	1,960	mW
DERATE FROM 25°C	-1.2	mW/ $^{\circ}\text{C}$
OPERATING, STORAGE TEMP.	-40 TO +85	$^{\circ}\text{C}$

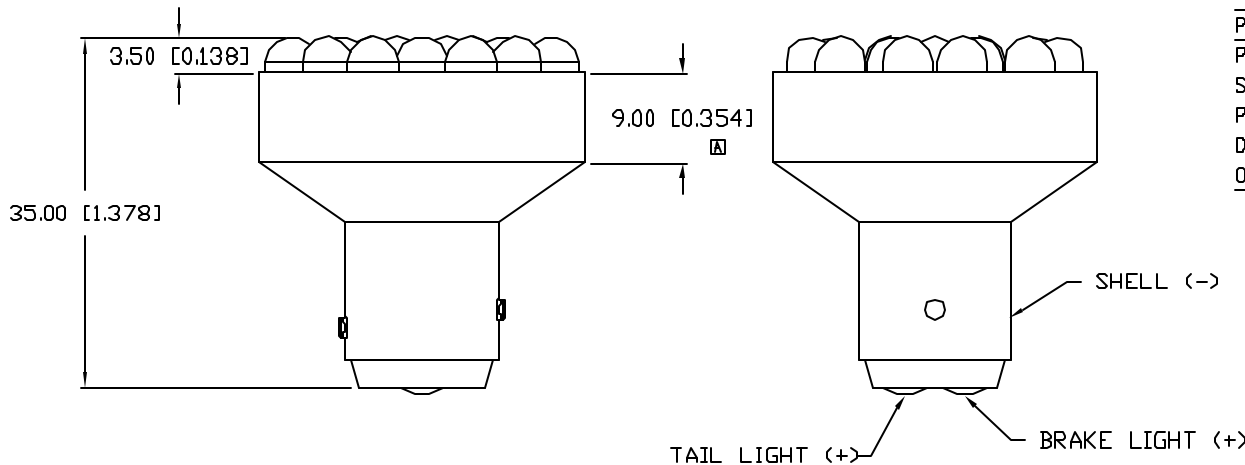

CAUTION: STATIC SENSITIVE DEVICE
FOLLOW PROPER E.S.D. HANDLING PROCEDURES
WHEN WORKING WITH THIS PART.

UNCONTROLLED DOCUMENT

*UNLESS OTHERWISE SPECIFIED TOLERANCES PER DECIMAL PRECISION ARE: X=±1 (±0.039), XX=±0.5 (±0.020), XXX=±0.25 (±0.010), XXXX=±0.127 (±0.005). LEAD SIZE=±0.05 (±0.002), LEAD LENGTH=±0.75 (±0.030). MIN = ^{+DECIMAL PRECISION}-0.00 ^{MAX = +0.00}-DECIMAL PRECISION

REV. C	PART NUMBER SSP-24MDB153S12G	CONFIDENTIAL INFORMATION THE INFORMATION CONTAINED IN THIS DOCUMENT IS THE PROPERTY OF SUNBRITE LEDS. EXCEPT AS SPECIFICALLY AUTHORIZED IN WRITING BY SUNBRITE LEDS, THE HOLDER OF THIS DOCUMENT SHALL KEEP ALL INFORMATION CONTAINED HEREIN CONFIDENTIAL AND SHALL PROTECT SAME IN WHOLE OR IN PART FROM DISCLOSURE AND DISSEMINATION TO ALL THIRD PARTIES.		286 E. HELEN ROAD PALATINE, IL 60067-6976 PHONE: +1.847.359.2790 FAX: +1.847.359.2867 WEB: www.sunbriteleds.com		
1.28" CIRCULAR, 24 LAMP POLYLED, 590nm AlInGaP YELLOW CHIPS, WATER CLEAR LENS, 1157 BASE, DOUBLE CONTACT AUTO BAYONET.		RELIABILITY NOTE DUR MANY YEARS OF EXPERIENCE DATA ACCUMULATION INDICATE THAT SOLDER HEAT IS A MAJOR CAUSE OF EARLY AND FUTURE FAILURE. PLEASE PAY ATTENTION TO YOUR SOLDERING PROCESS.		DRAWN: CT	CHECKED:	APPROVED: