

### OUTLINE OF SYSTEM

KIC9319F-002 is a C-MOS LSI designed for FM/MW/LW radio of PLL frequency synthesizer system corresponded to the requirement of the whole world. Since prescaler and LCD driver are built in addition to PLL and controller, the compact FM/MW/LW digital tuning system of high performance with clock car stereo can be constructed.

### RECEIVING BAND

AREA	CODE	BAND	RECEIVING BAND (Hz)	STEP (Hz)	f <sub>ref</sub> (Hz)	IF (Hz)	NOTE
	A2A1A0						
EUROPE	000 or 001	FM	87.5 ~ 108.0 M	50 k	50 k	+ 10.70 M	CODE="000" is 3 BAND version of Europe
		MW	522 ~ 1620 k	9 k	9 k	450 / 459 k	
		LW	153 ~ 281 k	1 k	1 k		CODE="001" is 2 BAND version of Europe
U.S.A 1	010	FM	87.5 ~ 107.9 M	200 k	50 k	+ 10.70 M	
		MW	520 ~ 1710 k	10 k	10 k	450 k	
U.S.A 2	011	FM	87.5 ~ 108.0 M	100 k	50 k	+ 10.70 M	
		MW	520 ~ 1710 k	10 k	10 k	+ 450 k	
LATIN AMERICA	100	FM	87.5 ~ 108.0 M	100 k	50 k	+ 10.70 M	
		MW	520 ~ 1620 k	5 k	5 k	+ 450 k	
AUSTRALIA MIDDLE AND NEAR EAST	101	FM	87.5 ~ 108.0 M	100 k	50 k	+ 10.70 M	
		MW	531 ~ 1602 k	9 k	9 k	450 / 459 k	
EASTERN EUROPE	110	FM	65.50 ~ 74.0 M 87.50 ~ 108.0 M	50 k	50 k	+ 10.70 M	
		MW	522 ~ 1620 k	9 k	9 k	450 / 459 k	
SOUTH AFRICA	111	FM	87.50 ~ 108.0 M	50 k	50 k	- 10.70 M	
		MW	531 ~ 1602 k	9 k	9 k	450 / 459 k	

### OUTLINE OF FUNCTION

#### TUNING FUNCTION

- MANUAL TUNING
  - MANUAL UP
  - MANUAL DOWN
- AUTO TUNING
  - SEEK UP, DOWN ... Once reception is mode, tuning stops at that station.
  - SCAN UP ... In case of receiving, tuning restart after 5 sec.
- PRESET MEMORY SCAN TUNING
- AUTO MEMORY TUNING
- IF count can be used (FM=10.7MHz, MW=450/459kHz)

} — step up down by push switch

# KIC9319F-002

- MEMORY FUNCTION

Preset memory can be selected among these combination.

- FM1, FM2, SDK, MW, LW each 6 STATIONS TOTAL 30 STATIONS
- FM1, FM2, MW, LW each 6 STATIONS TOTAL 24 STATIONS
- FM1, FM2, MW, each 6 STATIONS TOTAL 18 STATIONS

- OTHER FUNCTION

- SDK / SK function

- function switch

- 1) STEREO / MONO
- 2) LOCAL / DX
- 3) LOUDNESS ON / OFF
- 4) METAL TAPE / NORMAL TAPE
- 5) DOLBY ON / OFF
- 6) APS ON / OFF

- POWER ON / OFF FUNCTION

• remote control function. Since built-in function of remote decode, it can extend function (total 26 functions) as follows. (transmitter IC : KIC9243F)

- 1) all keys of KIC9319F-002 (16 keys)
- 2) 10 functions output by external driver KIC9174P

## TRACKING DATA

BAND	AREA	M1	M2	M3	M4	M5
FM	EUROPE, SOUTH AFRICA	87.5	87.9	97.9	105.9	108.0
	USA 1	87.5	87.9	97.9	105.9	107.9
	AUSTRALIA, LATIN AMERICA USA2, MIDDLE AND NEAR EAST	87.5	87.9	97.9	105.9	108.0
	EASTERN EUROPE	65.5	74.0	87.5	97.90	108.0
MW	EUROPE, EASTERN EUROPE	522	603	999	1404	1620
	USA 1, 2	520	600	1000	1400	1710
	LATIN AMERICA	520	600	1000	1400	1620
	AUSTRALIA, SOUTH AFRICA MIDDLE AND NEAR EAST	531	603	999	1404	1602
LW	EUROPE	153	164	218	272	281

# KIC9319F-002

KIC9319F-002 Layout

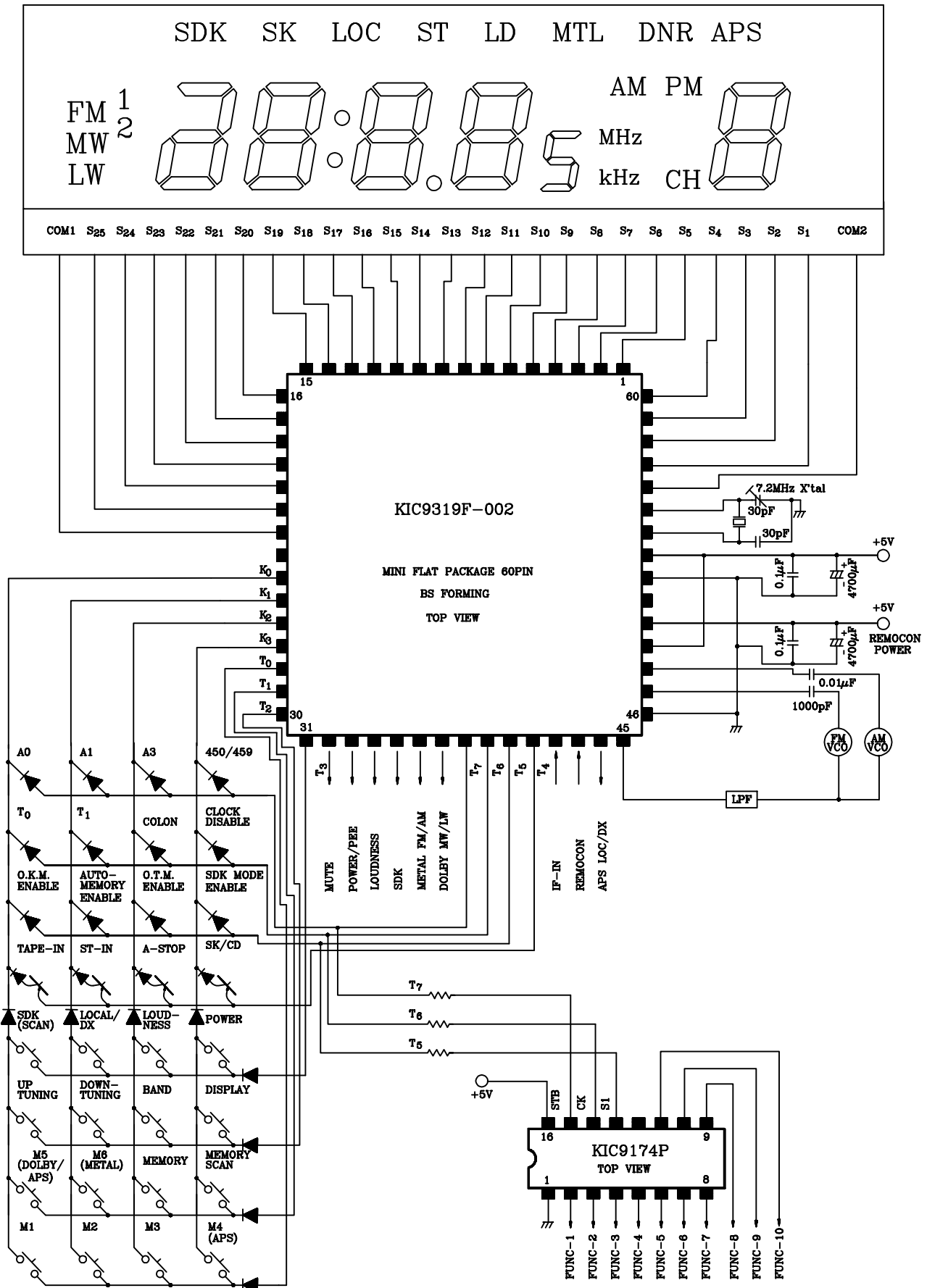

# KIC9319F-002

## SYSTEM BLOCK DIAGRAM

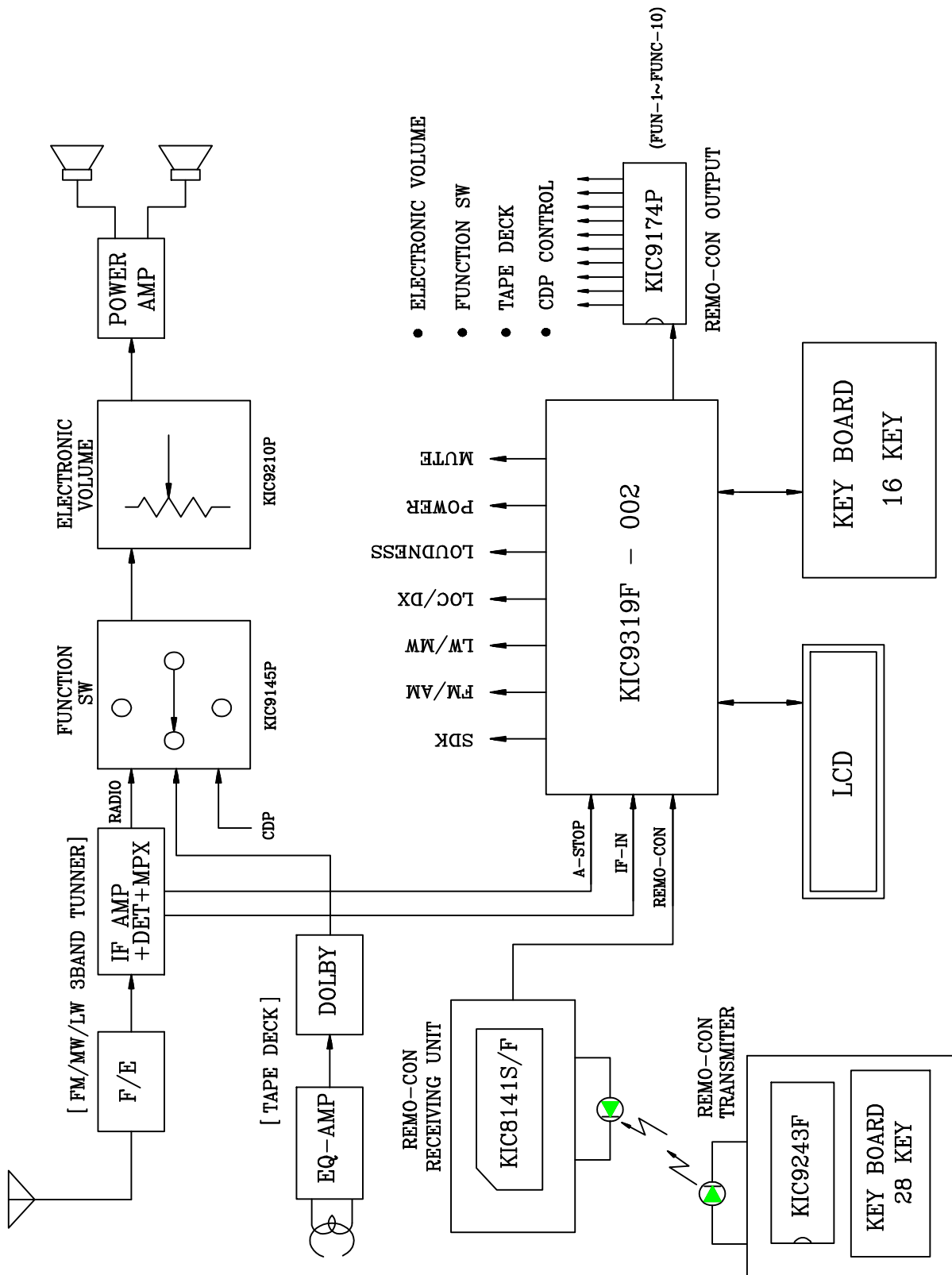

# KIC9319F-002

## KIC9319F-002 outline

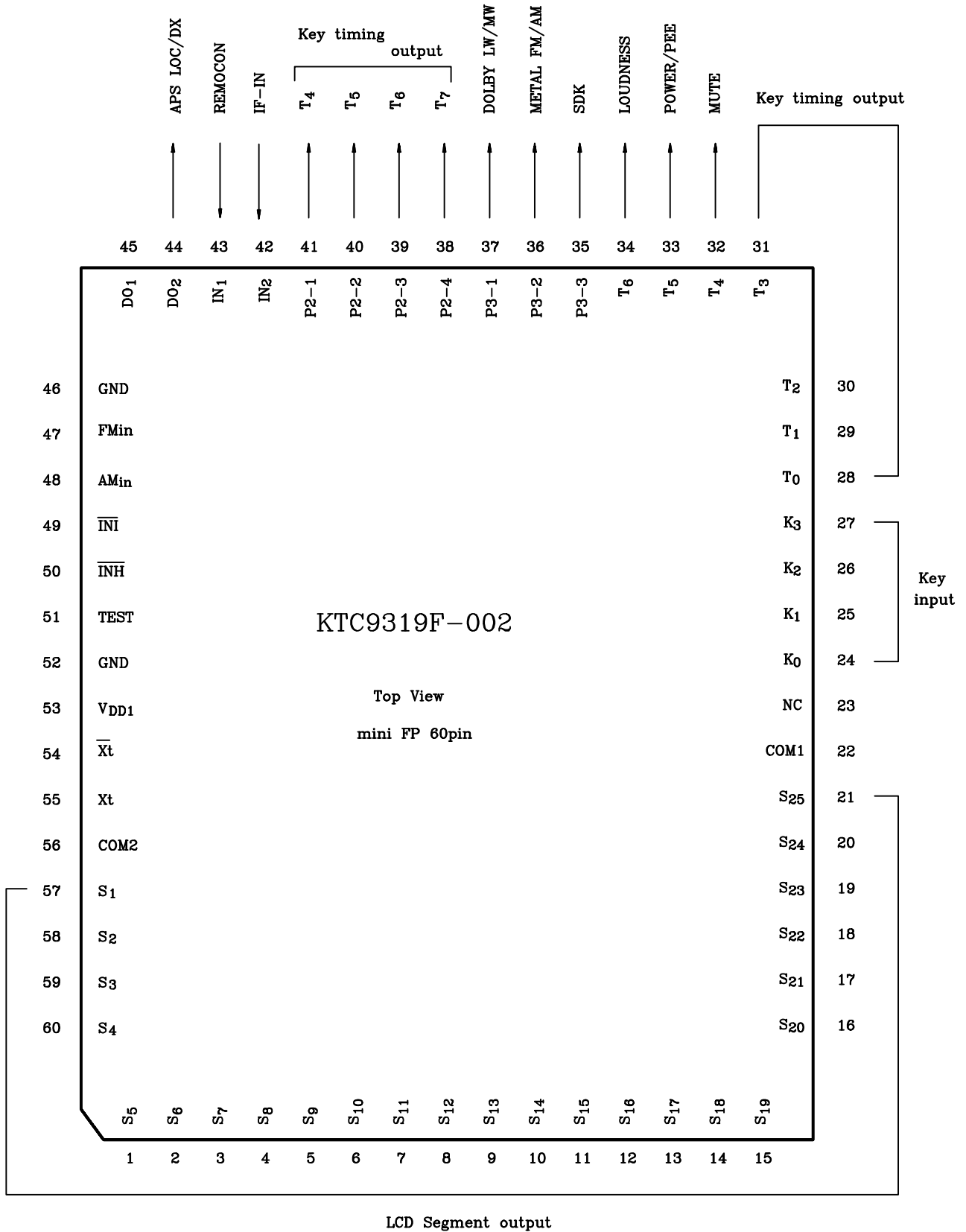

# KIC9319F-002

## KEY MAP

	K0	K1	K2	K3
T0	M1	M2	M3	M4 (APS)
T1	M5 (DOLBY /APS)	M6 (METAL)	MEMORY (CLOCK-ADJ.) [SCAN]	MEMORY SCAN (AUTO- MEMORY)
T2	UP- TUNING (M-ADJ.)	DOWN- TUNING (H-ADJ.)	BAND	DISPLAY
T3	SDK [SCAN]	LOCAL / DX	LOUDNESS	POWER
P2-1	**  TAPE-IN	**  ST-IN	**  A-STOP	**  SK/CD
P2-2	*  O·K·M (ANNOTAT- ION 1) ENABLE	*  AUTO- MEMORY ENABLE	*  O·T·M (ANNOTATION2) ENABLE	*  SDK MODE ENABLE
P2-3	*  T0	*  T1	*  COLON	*  CLOCK DISABLE
P2-4	*  A0	*  A1	*  A2	*  450/459
	K0	K1	K2	K3

## NOTE

NON LOCK SWITCH	*  DIODE JUMPER	**  TRANSISTOR SWITCH
--------------------	--------------------------	--------------------------------

ANNOTATION 1) O·K·M : One Key Memory

ANNOTATION 2) O·T·M : One Touch Memory

# KIC9319F-002

## FUNCTION

SYMBOL	EXPLANATION OF FUNCTION
M1~M3	Calling and writing preset memory. (ch 1 ~ ch 3)
M4 (APS)  M5 (DOLBY/APS)  M6 (METAL)	In radio mode, calling and writing preset memory. (4~6ch)  In tape mode, these keys act on tape function switch. When each function acts on, the mark on LCD is indicated and OUTPUT is made to set "H".  The keys are used for functions by setting of T0/T1.
MEMORY (CLOCK ADJ) [SCAN]	In clock mode, this key is used for setting of memory writing enable state and finish it. In clock mode, this key is used for setting of the clock adjusting enable state and finish it. Each enable state is clear after five second, when the designated key is not pushed during five second. This key can be used for scan up key in one-touch memory mode.
MEMORY SCAN (AUTO- MEMORY)	The preset memory scan function is started by pushing this key for less than 3 sec. (At the O.K.M mode, if this key pushed for more than 3 sec memory scan function is started.) The frequency written in memory is called in order, and if a station can be received at the frequency, the station will be received for 5 sec, then the display of channel number is flashing. In auto memory enable mode except O.K.M mode, If this key pushed for more than 3 sec, the auto memory function is started. The auto memory one cycle of the receiving band at local mode from current frequency. If the memories are not filled, it run one cycle again DX mode.
UP- TUNING (M-ADJ.) DOWN- TUNING (H-ADJ.)	In radio mode, the receiving frequency steps up or down by pushing this key 1 step/1 push. If this key is pushed for more than 0.5 sec, the seek tuning is started. When the key is pushed continuously, the seek tuning is not stopped if station detect signal (IF-IN or A-stop) is inputted. During clock adjusting enable state, adjustment for the minute or the hour.

# KIC9319F-002

## FUNCTION

SYMBOL	EXPLANATION OF FUNCTION
BAND	<p>Changing the receiving band cyclically Every pushing of this key, the band is changed as shown below.</p> <p style="text-align: center;">   <span style="border: 1px solid black; padding: 2px;">→ FM 1 → FM 2 → MW → (LW)</span> </p>
DISPLAY	<p>Changing displays of clock, frequency and CD. This function is invalid in no clock mode.</p>
SDK [SCAN]	<p>Changing receiving band to SDK band. (SDK is available if Europe area if SDK enable jumper is set.) In SDK band, the "SDK" mark on LCD is indicated and the SDK OUTPUT is made to set "H". And it is necessary that the SK INPUT is detected with the auto stop signal, for stopping of the seek/scan tuning and the auto memory tuning. The way of changing to the band that was received before is to push the [SDK] key or the [BAND] key. When SDK enable jumper is not set, this key is used as scan key. Note) If SDK enable jump is set, this key is invalid this area shown above.</p>
LOCAL/DX	<p>Changing LOCAL/DX in radio mode. The LOCAL OUTPUT is made to set "H", During seek/scan and the "LOC" mark on LCD is indicated, when the LOCAL is selected.</p>
LOUDNESS	<p>Changing ON/OFF of LOUDNESS in radio. The LOUDNESS OUTPUT is made to set "H" and the "LD" mark on LCD is indicated, when the LOUDNESS function turn on.</p>
POWER	<p>Changing ON/OFF of power. Power OUTPUT changes cyclically as follows.</p> <p style="text-align: center;">   <span style="border: 1px solid black; padding: 2px;">→ H → L</span> </p> <p>During power OFF, it becomes stand-by mode and inputs are ignored except power key of main key matrix and remote control input.</p>



# KIC9319F-002

## FUNCTION

SYMBOL	EXPLANATION OF FUNCTION
** TAPE-IN	Detected for tape action. The tape is act on : transistor on.
** ST-IN	Stereo input. In FM band, the "ST" mark on LCD is indicated. If transistor ON, stereo indicated.
** A-STOP	Auto stop signal input for auto-tuning. Station is detected : transistor ON
** SK/CD	In SDK mode, (when SDK diode is set.) this input becomes SK signal input. When SDK diode is not set, this input becomes CD input. When CD input turn on, "cd" is displayed on LCD, and indications of radio/tape turn off. But "LD" and "DISPLAY" key is valid. Input on : transistor ON.
* O•K•M ENABLE	Setting action of one key memory The diode is set. : One key memory enable (The number of preset memory : S6) The diode is not set. : Memory function is decide by O.T.M enable jumper.
* O•T•M ENABLE	Setting action of one touch memory.  The diode is set. : If preset memory key is pushed more than 3 seconds continuously, the frequency is written in preset memory. • Clock adjustment (hour/minute) is caused by UP/DOWN key with pushing DISPLAY key. • MEMORY key is valid as SCAN-UP TUNING key. The diode is not set. : After MEMORY key pushed, if preset key pushed within 5 seconds, frequency is written. • Clock adjustment is caused by UP/DOWN key within 5 seconds after that MEMORY key is pushed.

\*\* TRANSISTOR SWITCH

\* DIODE JUMPER



# KIC9319F-002

## I/O PORTS

PORT	NO.	NAME	FUNCTION	ACTIVE	INT.															
P2-1	41	SI	KIC9174P/F SERIAL OUTPUT (output extension port)	H	L															
P2-2	40	SO																		
P2-3	39	CK																		
P2-4	38	STB																		
P3-3	35	SDK	SDK BAND OUTPUT	H	L															
P3-2	36	FM / AM (METAL)	• RADIO MODE OUTPUT. <table border="1" style="margin: 5px auto;"> <thead> <tr> <th>BAND OUTPUT</th> <th>FM</th> <th>FM (L)</th> <th>MW</th> <th>LW</th> </tr> </thead> <tbody> <tr> <td>FM/AM</td> <td>1</td> <td>1</td> <td>0</td> <td>0</td> </tr> <tr> <td>LW/MW</td> <td>0</td> <td>1</td> <td>0</td> <td>1</td> </tr> </tbody> </table>	BAND OUTPUT	FM	FM (L)	MW	LW	FM/AM	1	1	0	0	LW/MW	0	1	0	1	H	(H)
BAND OUTPUT	FM	FM (L)		MW	LW															
FM/AM	1	1		0	0															
LW/MW	0	1	0	1																
P3-1	37	LW / MW (DOLBY/APS)		H	L															
D02	44	LOC / DX	INIT. : FM (FM1) function output of tape mode.	H	L															
T6	34	LOUDNESS	LOUDNESS output	H	L															
T5	33	POWER / PEE	POWER control output and PEE sound output	H	H															
T4	32	MUTE	mute output	H	H															
IN-2	42	IF-IN	IF input for auto stop	AC	-															
IN-1	43	REMOCON	REMOTE CONTROL input	L	-															

# KIC9319F-002

Extend output port (KIC9174P/F)

PORT	PIN NO.	NAME	FUNCTION		ACTIVE	INT.
OP-1	2	FUNC-1	continuous output	remote control decoder output (for extend)	L	HZ (high impede- nce)
OP-2	3	FUNC-2				
OP-3	4	FUNC-3				
OP-4	5	FUNC-4				
OP-5	6	FUNC-5				
OP-6	7	FUNC-6				
OP-7	8	FUNC-7				
OP-8	9	FUNC-8				
OP-9	10	FUNC-9	cyclic output			
OP-10	11	FUNC-10				

Remote control  
transmission IC (KIC9243F) key map

KEY-No.	NAME
K01	M 1
K02	M 2
K03	M 3
K04	M 4
K05	M 5
K06	M 6
K07	MEMORY
K08	M-SCAN

KEY-No.	NAME
K09	UP
K10	DOWN
K11	BAND
K12	DISPLAY
K13	SDK
K14	LOCAL
K15	LOUDNESS
K16	POWER

KEY-No.	NAME
K17	-
K18	-
K19	-
K20	-
K21	-
K22	-
K23	FUNC-1
K24	FUNC-2

KEY-No.	NAME
K25	FUNC-3
K26	FUNC-4
K27	FUNC-5
K28	FUNC-6
K29	FUNC-7
K30	FUNC-8
K31	FUNC-9
K32	FUNC-10

remote control system code of KIC9319F-002 is "92H".

# KIC9319F-002

## LCD map

SYMBOL	PIN NO.	SEGMENT NAME		FUNCTION
		COM1	COM2	
COM 1	22	COM1	-	common 1
S 25	21	FM1	FM2	FM1 / FM2 : memory bank
S 24	20	LOC	FM	FM / MW / LW : receiving band LOC : LOCAL mode SDK : SDK band 1a~g : 23:55 / 108.0
S 23	19	MW	LW	
S 22	18	SDK	1adeg	
S 21	17	1b	1c	
S 20	16	2f	2b	2a~g : 23:25 / 108.0 ": " : colon of clock
S 19	15	2e	2g	
S 18	14	2d	2c	
S 17	13	2a	:	
S 16	12	3f	3b	3a~g : 23:55 / 108.0 SK : SK signal
S 15	11	3e	3g	
S 14	10	3d	3c	
S 13	9	3a	SK	
S 12	8	4f	4b	4a~g : 23:25 / 108.0 5a~g : FM 50kHz
S 11	7	4e	4g	
S 10	6	4d	4c	
S 9	5	4a	5acdfg	
S 8	4	AM	kHz	AM / PM : for 12H clock kHz : for MW / LW band CH : preset memory channel ST : STEREO LD : LOUDNESS 6a~6g : for memory channel number MTL : METAL APS : auto program search DNR : DOLBY
S 7	3	PM	CH	
S 6	2	ST	LD	
S 5	1	6b	6c	
S 4	60	6e	6g	
S 3	59	6f	6b	
S 2	58	6a	APS	
S 1	57	MTL	DNR	
COM2	56	-	COM2	common 2

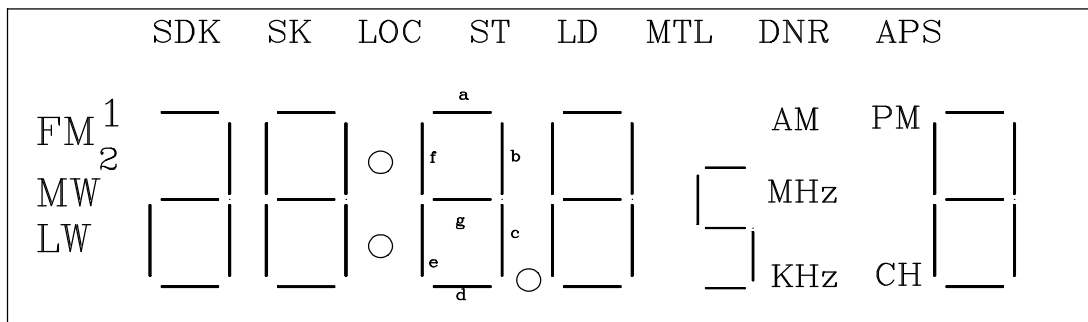

## BAND CHANGE

1. Principal function  
changing the receiving band
2. Key and I/O port to be used  
[BAND] key, A0, A1, A2 jumper, FM/AM OUTPUT, LW/MW OUTPUT  
[SDK] (When SDK Enable jumper is set.)
3. Functions
  - a. Every pushing the [BAND] key, the receiving band is changed cyclically.  
The order of changing band is as follows.

- In case of A0, A1, A2 = 0, 0, 0

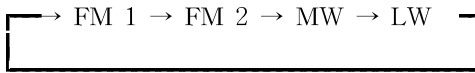

- other case

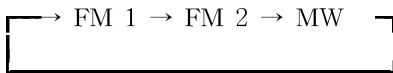

- b. When band is changed, the FM/AM OUTPUT and The LW/MW OUTPUT are as follows.

PORT	FM(SDK)	MW	LW	FM(L)
FM/AM	H	L	L	H
LW/MW	L	L	H	H

- c. The receiving band is changed to SDK band by pushing the [SDK] key.
    - d. The receiving band is return back to the band that was received before the SDK band, by pushing the [SDK] key again or pushing the [BAND] key.
    - e. The "FM" mark and the "MHz" mark are indicated when the receiving band is FM.  
The "MW" mark and the "kHz" mark are indicated when the receiving band is MW.  
The "LW" mark and the "kHz" mark are indicated when the receiving band is LW.  
The "SDK" mark, the "MHz" mark and the "FM" mark are indicated when the receiving band is SDK.
  - f. As soon as band is changed, MUTE OUTPUT is outputted for 1 second.

# KIC9319F-002

## MANUAL TUNING AND SEEK TUNING

### 1. Principal function

Manual up/down of receiving frequency and auto tuning.

### 2. Key to be used

[UP(MA)] key, [DOWN(HA)] key.

### 3. Functions

- a. The 1step/1push tuning is executed by pushing the [UP(MA)] or [DOWN(HA)] key.
- b. If the key has been pushed for more than 500mS, the seek tuning starts.
- c. The tuning method is the saw tooth wave form method, and when the receiving frequency reached the band edge, it goes to the opposite side and the continuous tuning is held for 500mS.
- d. The seek tuning is stopped, if the stop signal is detected on the A-STOP INPUT or the intermediate frequency is counted by the IF counter.  
But when the key is pushed continuously, the seek tuning is not stopped if the station can be received.
- e. The speed of the seek tuning is 50mS step.
- f. When the local is selected (the "LOC" mark is indicated), the LOCAL OUTPUT is outputted "H" during seek tuning.
- g. The seek tuning is stopped in SDK band, when the SK input is "H" with the condition attached as shown above.
- h. When the seek tuning starts, PEE sound is outputted as follows.

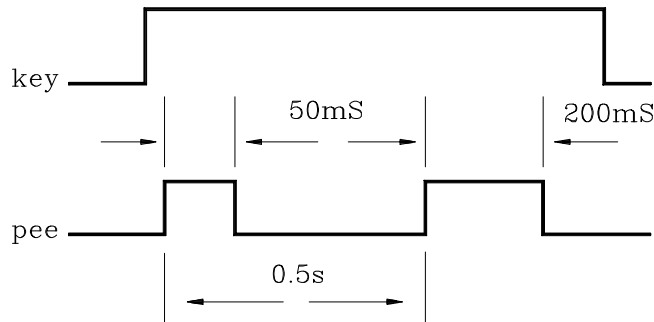

## SCAN TUNING

### 1. Principal function

Executing up auto tuning, if detected stations, auto tuning is stopped for 5 seconds.  
If designated key is not pushed, the scan tuning is carried on again.

### 2. Key to be used

In case of O.T.M (One Touch Memory) mode, [MEMORY] key is used as [SCAN] key.  
When SDK mode is not used, [SDK] key is changed to [SCAN] key.

### 3. Functions

- a. The scan tuning function is started by pushing the [SCAN] key.
- b. The scan tuning is stopped for 5 seconds, if the stop signal is detected on the A-STOP INPUT or the intermediate frequency is counted by the IF counter.  
During the scan tuning is held, indicator of frequency flashing for 1Hz.
- c. The scan tuning stop for 5 seconds in SDK band, when the SK-IN is inputted with the condition attached as shown above.
- d. If the [MEMORY (CLOCK-ADJUSTMENT)] key is pushed during scan tuning is held, it is the memory writing enable state for 5 seconds. During the memory writing enable state, if a memory number key ([M1]~[M6]) is pushed, the receiving frequency is written in the preset memory. And that state is released and the scan tuning is stopped.  
During the memory writing enable state, if the [MEMORY (CLOCK-ADJUSTMENT)] key is pushed again, the receiving frequency is changed to the next step and the scan tuning is continued.  
In O.T.M mode, if [M1~M6] key is pushed for more than 3 seconds while scan tuning is stopped for 5 seconds, receiving station is stored to memory, and scan tuning is stopped. In O.K.M mode, refer to P.6
- e. When the [SCAN] key is pushing continuously, the scan tuning is not stopped if stop signal is detected.
- f. The tuning method is the saw tooth wave form method, and when the receiving frequency is reached the band edge, it goes to the opposite side of that band and the continuous tuning is held for 500mS.
- g. The speed of the scan tuning is 50mS/step.
- h. When the local is selected (the "LOC" mark is indicated), the LOCAL OUTPUT is output "H" during the scan tuning.



# KIC9319F-002

## AUTO STOP AND IF COUNTER

### 1. Principal function

Detecting A-STOP signal or Counting IF

### 2. I/O to be used

IF-IN INPUT, A-STOP INPUT

### 3. Functions

- a. The intermediate frequency (IF) is counted as condition of stopping for the auto memory, the seek/scan tuning and the memory scan.
- b. It is judged to be station when the IF-IN INPUT or A-STOP INPUT is inputted stop signal.
- c. The IF is inputted on IF-IN, and counted.  
 If the IF counted is in wide range, after 100mS the IF is counted on same receiving frequency again.  
 If the IF counted is in narrow range, it is judged to be the station.  
 When A-STOP INPUT is detected, it is also judged to be the station.  
 It is judged to be station in SDK band when the SK-IN INPUT is "H" with the condition attached as shown above.

#### ① In case of IF check

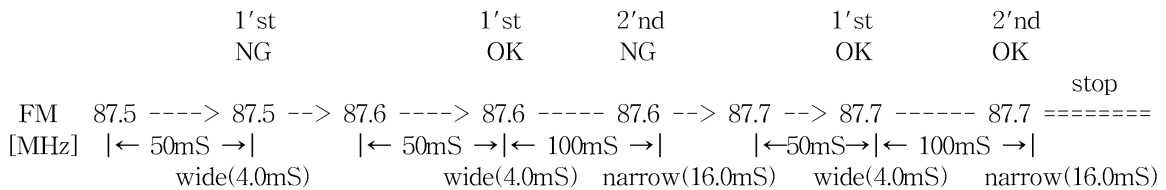

#### ② In case of IF check (SDK band)

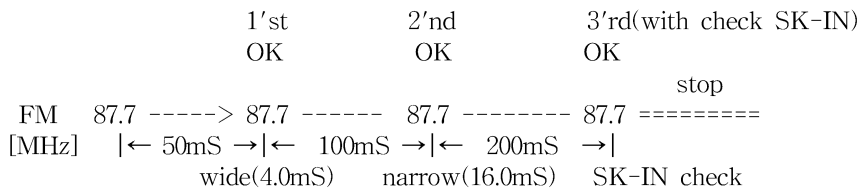

### d. Setting value of IF check

BAND	REFERENCE FREQUENCY [Hz]	First counting (WIDE)		Second counting (NARROW)	
		DETECTED WIDTH [Hz]	GATE TIME [mS]	DETECTED WIDTH [Hz]	GATE TIME [mS]
MW	5 k	450k ± 12.0k (459k ± 12.0k)	4.0	450k ± 3.0k (459k ± 3.0k)	16.0
	9 k				
	10 k				
FM	25/50 k	10.7M ± 60k	4.0	10.7M ± 15k	16.0
LW	1 k	450k ± 2.4k (459k ± 2.4k)	4.0	450k ± 0.6k (459k ± 0.6k)	16.0

\* ( ) : In case the jumper of the 459k/450k is set.

PRESET MEMORY (When O.K.M enable diode is set, refer to P6)

1. Principal function

Calling and writing in the preset memory

2. Key to be used

[M1]~[M6 (METAL)] key, [MEMORY (CLOCK-ADJUSTMENT)] key.

3. Functions

a. There are maximum 12 stations for FM band, maximum 6 stations for MW band and each 6 stations for LW/SDK band.

b. In case of calling the preset memory

① The receiving frequency written in the memory is called by the pushing the [M1]~[M6 (METAL)] key.

② At the time the [M1]~[M6 (METAL)] key is pushed, the MUTE output is set to "H" for 600mS. However the MUTE output is not set to "H" if the memory number of the key pushed and the memory number that is receiving now is same.

c. In case of writing in preset memory (O.T.M jumper is not set.)

① If the [MEMORY (CLOCK-ADJUSTMENT)] key is pushed in radio and SDK mode, it is the memory writing enable state for 5 seconds.

② The "CH" mark flashes at 1Hz rate in the memory writing enable state.

③ If the [M1]~[M6 (METAL)] key is pushed in the memory writing enable state, the receiving frequency is written in the memory of the key pushed.

④ If the receiving frequency is written in the preset memory, the "CH" mark is indicated and the memory number of the key pushed is indicated on LCD.

⑤ If the [MEMORY (CLOCK-ADJUSTMENT)] key is pushed in the memory writing enable state, the state is released.

⑥ After 5 seconds from setting of memory writing enable state, the state is released, and "CH" mark is turned off.

d. In case of one touch memory (O.T.M jumper is set).

① If [M1]~[M6] key is pushed for less than 3 seconds, called preset memory.

② If [M1]~[M6] key is pushed for more than 3 seconds, the receiving frequency is written in the memory of the key pushed.

③ In clock mod, if [M1]~[M6] key is pushed, called preset memory, and in this time, if key is pushed for more than 3 seconds, the frequency is not written in the memory.

## ONE KEY MEMORY MODE

### 1. Principal function

Calling and writing in the preset memory by one key.

### 2. Key to be used

[MEMORY] key, [MEMORY-SCAN] key

### 3. Functions

a. When O.K.M enable diode is set, there is one key memory action.

b. In one key memory mode, DTS function is as follows.

① The number of preset memory for FM band is fixed 6 stations. (There is not FM2.)

② Auto memory action is disable.

③ O.T.M enable jumper is ignored.

④ Memory scan is started when [memory scan] key is pushed for more than 3s.

c. In case of calling and writing preset memory

① IF [MEMORY-SCAN] key is pushed during radio mode, call next preset memory.  
And when preset memory is not call, call 1 channel.

② If the [MEMORY] key is pushed, it is the memory writing enable state.  
The "CH" mark flashes at 1Hz rate in the memory writing enable state.

③ During writing enable state, [MEMORY-SCAN] key can select preset memory.

④ [MEMORY] key is pushed again, writing action is finished.

⑤ If [MEMORY] key is not pushed again for less than 5 seconds, frequency is not written in preset memory.

## MEMORY SCAN

### 1. Principal function

Calling the preset memory in order.

### 2. Key to be used

[MEMORY-SCAN (AUTO-MEMORY)] key.

### 3. Functions

a. When the [MEMORY-SCAN (AUTO-MEMORY)] key is pushed for less than 3 seconds, (in O.K.M enable mode, more than 3 seconds.) the memory scan function is started from next memory number of receiving memory number.

If the preset memory is not called, the memory scan function is started from 1 channel.

In the memory scan, the frequency written in the memory is received for 5 seconds in order.

b. During memory scan, the channel number flashes at 1Hz.

c. The number of memory reached 6 channel, the band is changed as shown below and memory scan is continuous from channel.

① In case of FM band.

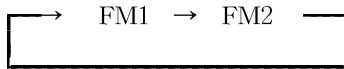

\* in O.K.M enable mode, FM1 only

d. If the station is not received (by check the IF or A-STOP signal) when the preset memory is called, the next preset memory is called immediately.

If the station is received, the next preset memory is called after receiving the station for 5 seconds.

e. When the [MEMORY-SCAN (AUTO-MEMORY)] key is pushed in the memory scan, the memory scan is stopped on the preset memory that is receiving now.

## AUTO MEMORY

### 1. Principal function

Writing the station in the preset memory automatically.

### 2. Key to be used

[MEMORY-SCAN (AUTO-MEMORY)] key.

### 3. Functions

#### a. The search tuning is started from station of receiving now.

When the [MEMORY-SCAN (AUTO-MEMORY)] key is pushed for more than 2 seconds, search is started from current frequency, and the writing is started from 1 channel of current band.

Search is running for one cycle at "LOC" mode, and if memory is not full, running for one more cycle at "DX" mode.

#### b. During the auto memory, the "CH" mark and memory channel display flashes at 1Hz rate.

#### c. If stations have been received when auto memory action finished then 1 channel is called.

If station have not been received, start frequency is received.

#### d. In case of FM band, the memory band is changed as shown below.

##### ① In case of receiving FM1 band.

FM1 → FM2

##### ② In case of receiving FM2 band, writing only FM2 band.

#### e. In case of O.K.M Enable mode, auto memory is disable.

# KIC9319F-002

## FUNCTION CHANGE

### 1. With clock function (In case of the diode is not CLOCK-DISABLE)

$\overline{\text{INH}}$	CD-IN	TAPE	MODE	DISPLAY	KEY ACTION	ETC.
"L"	-	-	MEMORY BACK-UP	NO INDICATION	INVALIDITY	MEMORY BACK-UP CLOCK COUNT
"H"	"L"	"L"	RADIO	CLOCK	RADIO	The double key is radio action.
		"H"	TAPE	CLOCK + TAPE	TAPE	The double key is tape action.
	"H"	"L" / "H"	CD	CD	Valid only LD/ DISPLAY KEY	Clock display enable by DISPLAY key.

### 2. Without clock function (In case of the diode is set on the CLOCK-DISABLE)

$\overline{\text{INH}}$	CD-IN	TAPE	MODE	DISPLAY	KEY ACTION	ETC.
"L"	-	-	MEMORY BACK-UP	NO INDICATION	INVALIDITY	MEMORY BACK-UP crystal oscillation stop
"H"	"L"	"L"	RADIO	RADIO	RADIO	The double key is radio action.
		"H"	TAPE	TAPE	TAPE	The double key is tape action.
	"H"	"L" / "H"	CD	CD	Valid only LD KEY	-

CAUTION : [Display key] is invalid.

### 3. In case of SDK mode (With SDK jumper)

TAPE	SDK	MODE	DISPLAY	KEY ACTION / ETC.
"L"	OFF	RADIO	RADIO	The double key is radio key. The cancel of SDK mode is caused by pushing of SDK or BAND key.
	ON			
"H"	OFF	TAPE	TAPE (CLOCK)	The double key is tape key.
	ON	SDK monitor	RADIO	The double key is radio key, but function output is tape mode. The cancel of SDK mode is caused by pushing of SDK key.

## CLOCK

### 1. Principal function

The clock of 12 hours and 24 hours displayed.

### 2. Key and I/O to be used

[UP (MA)] Key, [DOWN (HA)] Key, [DISPLAY] Key, [MEMORY (CLOCK-ADJUSTMENT)] Key, CLOCK-DISABLE jumper.

### 3. Functions

a. The clock is invalid in case the diode is set on the CLOCK-DISABLE jumper.

b. The display changes to the CLOCK display by pushing the [DISPLAY] key in the CDP display and the frequency display. The [DISPLAY] key is pushed again when the clock is indicated in SDK and radio mode, the display returns back to one that was being indicated before.

c. In the power off mode, The clock is display but can not be clock adjusted.

d. The clock adjusting (In case of O.T.M jumper is not set)

- ① If the [MEMORY (CLOCK-ADJUSTMENT)] key is pushed in clock display, the clock adjusting state is set for 5 seconds. The display flashes in this state. In this state, the hour is adjusted by pushing the [DOWN (HA)] key, and the minute is adjusted by pushing the [UP (MA)] key.
- ② Any key except the [MEMORY (CLOCK-ADJUSTMENT)] key, [UP (MA)] key, [DOWN (HA)] key are invalid in the clock adjusting state.
- ③ When the [MEMORY (CLOCK-ADJUSTMENT)] key is pushed in the clock adjusting state, the second of the clock is set to the zero and that state are released.
- ④ The minute or the hour step up by 1step/1push. The minute or the hour step up continuously by 1step/250mS, when the key is pushed for more than 500mS.
- ⑤ In the clock adjusting state, the clock display does not flash during pushing the [UP (MA)] key or the [DOWN (HA)] key.
- ⑥ If the key is not pushed for 5 seconds in clock adjusting state, that state will be released. In this case, the second is not set the zero.

e. The clock adjusting (In case of O.T.M jumper is set)

- ① As [DISPLAY] key is pushing during frequency display, the hour is adjusted by pushing the [DOWN (HA)] key, and the minute is adjusted by pushing the [UP (MA)] key.
- ② After clock adjusted when the [DISPLAY] key is released in the clock adjusting state, the second of the clock is set to the zero and that state are released.
- ③ Clock can not be adjusted from remote controller.

f. The clock is 24 hour display in Europe area (A2/A1/A0="000", "001", "110"). In other area, the clock is 12 hour display. (with "AM" and "PM" mark)

g. If the radio related key except [MEMORY (CLOCK-ADJUSTMENT)] key [LOCAL/DX] key (In O.T.M mode, [M1]~[M6] key) is pushed when the clock is indicated in radio mode or SDK mode, the display change to the frequency and then the action of the key pushing is executed.

## BUZZER

### 1. Principal function

The buzzer sound is outputted when the function key is pushed.

### 2. I/O to be used

Power/PEE OUTPUT.

### 3. Functions

a. The frequency of the buzzer sound is 3kHz.

b. The buzzer sound output for 50mS when the function key is pushed.

c. In case of O.T.M mode, the buzzer sound is outputted for 200mS when the frequency is written in the preset memory by [M1]~[M6 (METAL)] key, and when the auto memory is started by [MEMORY -SCAN (AUTO-MEMORY)] key.

- In case of O.K.M mode, the frequency is written in the memory. 200mS
- Start of memory scan, seek and scan. 200mS

## REMOTE CONTROL

### 1. Principal function

Many function can be control from outside because of included remote control decoder.

### 2. I/O to be used

REMOCON INPUT (IN-1)

### 3. Functions

a. The transmission IC is KIC9243F.

b. The custom code for the remote control is "92H".

c. The main key of KIC9319F (16keys) can be control.

d. Output of 10 function can take out by connected to KIC9174P, KIC9174F.



## SDK FUNCTION

### 1. Principal function

Receiving the traffic information station.

### 2. Key and I/O to be used

[SDK] key, SDK OUTPUT, SK INPUT

### 3. Functions

a. The receiving band is changed to the SDK band by pushing the [SDK] key.

The [SDK] key is only valid in Europe area (A2/A1/A0="000", "001", "110").

The cancel of SDK mode is caused by pushing [SDK] or [BAND] key.

b. In SDK band, the "SDK", "FM" mark is indicated and the SDK OUTPUT is "H".

c. It is necessary that the SK input is detected with the auto stop signal (by the A-STOP INPUT or the IF COUNTER), for stopping of seek/scan tuning, writing a memory of auto memory.

d. When mode/band is changed to SDK mode/band from normal FM band, after 0.5 second stop signal is checked. When band is changed to SDK band from the other band, after 1.0 second stop signal is checked.

If stop signal is detected, after 0.5 second SK signal is checked.

If SK signal can be detected the frequency is received.

If SK signal can not be detected, SDK search is started.

e. If SK signal is detected after 0.2 second of detecting stop signal, the frequency is received.

f. In SDK searching mode, LOC mode is canceled.

g. In SDK searching mode, SDK indicator flash.

h. When tape act in SDK mode, radio action is kept and tape display is indicated.

The I/O port output is changed from radio mode to tape mode, without MUTE output.

i. In SDK monitor mode, [BAND], [LOCAL/DX], [MEMORY] (contain AUTO MEMORY) key is invalid.

j. The [M4]~[M6] keys are acted as preset memory keys, it has no concern with T0, T1.

(Tape function is valid when SDK mode is canceled.)

k. In SDK monitor mode, if SDK key is pushed then SDK monitor mode is canceled and it becomes normal tape mode.

l. In tape mode, if [SDK] key is pushed then mode is changed to SDK monitor mode and stop signal and SK INPUT signal is detected.

# KIC9319F-002

m. The example of I/O ports connection at SDK mode

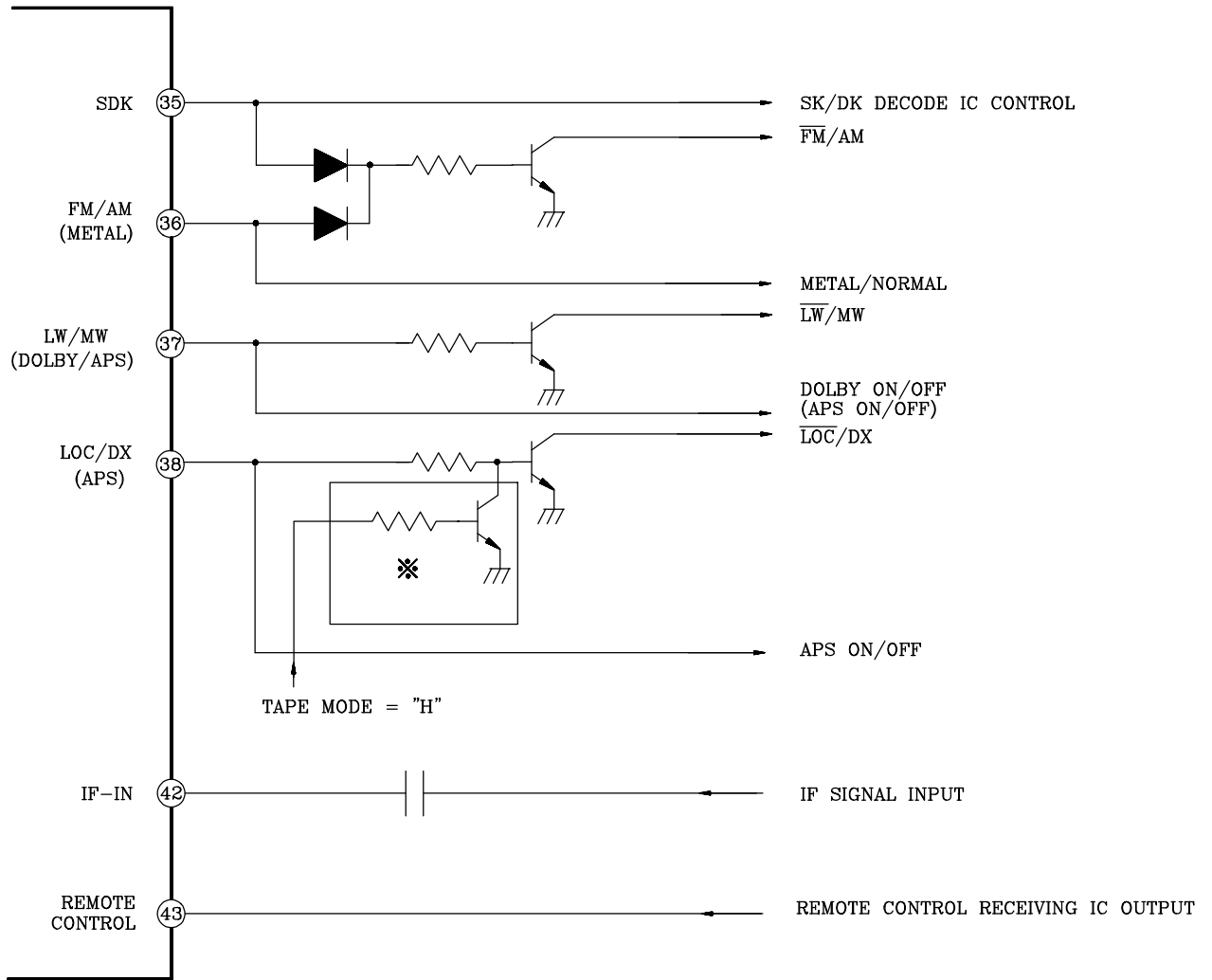

※ This circuit is for fixing local mode when using SDK mode and full tape function mode ( $T_0/T_1=1/1$ ). In the other case it is not needed.

# KIC9319F-002

## POWER ON/OFF FUNCTION

### 1. Principal function

Power ON/OFF can be control by [POWER] key, so ON/OFF of set power can be cyclic switch.

### 2. Functions

- When INH="H", executed ON/OFF of power by [Power] key.
- When power ON, Power output is "H" level, and KIC9319F is normal action.
- When power OFF, display is clock and power output is "L" level.  
At this time, only [POWER] key of panel and remote control is enable, and other keys is disable.
- Power ON/OFF timing

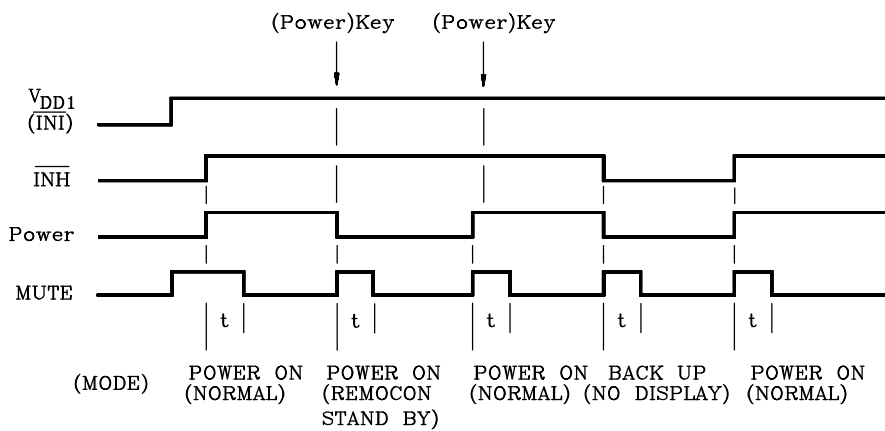

● t : Muting time = About 3 Seconds.

### e. Power supply circuit

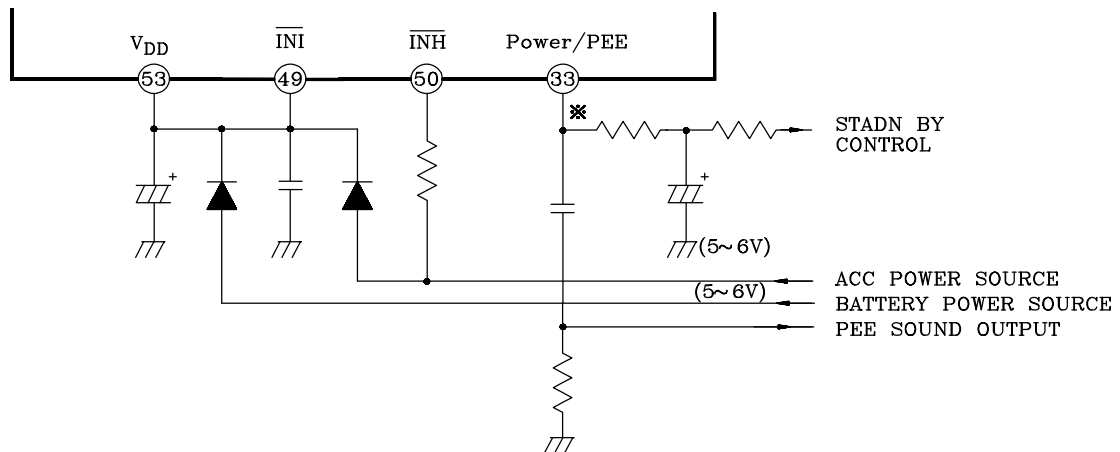

※ When [Power] key is not used, Power/Pee output is only used as pee sound output.

# KIC9319F-002

## CHANGE OF MODE BY KEY INPUT.

a. In case of the preset scan function and the auto memory function.

KEY	DURING THE PRESET SCAN FUNCTION	DURING THE AUTO MEMORY FUNCTION
M1 ~ M6	The function is stopped and the action of the key pushed is executed. At O.K.M mode, M1~M6 key is invalid.	
MEMORY	INVALID	
MEMORY SCAN	The preset scan function is stopped.	The function is stopped and the frequency return back to the frequency of when the auto store started.
UP / DOWN		The starting frequency of auto memory function is written in the last memory and the receiving band is changed.
SEEK		
BAND		
DISPLAY	INVALID	
LOUDNESS	The function is not stopped and the action of the key pushed is executed.	
LOCAL / DX	The function is not stopped and the action of the key pushed is execute.	INVALID
SDK	The preset scan function is stopped.	The starting frequency of auto memory function is written in the last memory and the receiving band is changed.

b. In case of the seek tuning and the scan tuning function.

KEY	DURING THE SEEK TUNING FUNCTION	DURING THE SCAN TUNING FUNCTION
M1 ~ M6	The function is stopped and the action of the key pushed is executed.	
MEMORY	INVALID	refer to page 20
MEMORY SCAN	When key is pushed, executing preset scan from 1 channel of the receiving band.	
UP / DOWN	The function is stopped.	
SCAN	When key is pushed, scan tuning is executed.	The last holding frequency or starting frequency is written in the last memory and the receiving band is changed.
BAND	The frequency of when the seek tuning was started is written in the last memory and the receiving band is changed.	
DISPLAY	INVALID	
LOUDNESS LOCAL / DX	The function is not stopped and the action of the key pushed is executed.	
SDK	The starting frequency is written in the last memory and the receiving band is changed.	The last holding frequency or starting frequency is written in the last memory and the receiving band is changed.

# KIC9319F-002

c. In case of the memory writing enable and the clock adjusting enable state.

KEY	DURING THE MEMORY STORE MODE	DURING THE CLOCK ADJUSTMENT MODE
M1 ~ M6	The receiving frequency is written in memory of the key pushed. In O.K.M invalidly.	INVALID
MEMORY	The state is released.	The second is set the zero and the state is released.
MEMORY SCAN	In O.K.M, preset memory is selected.	INVALID
UP / DOWN	The state is released and the action of the key pushed is executed.	The hour is adjusted by pushing the DOWN key. The minute is adjusted by pushing the UP key.
SCAN		INVALID
BAND		
DISPLAY		
LOUDNESS	The action of the key pushed is executed and the state is not released.	
LOCAL / DX		
SDK	The state is released and the action of the key pushed is executed.	

# KIC9319F-002

- Application example of KIA8141S for receiving amplifier circuit of remote control.

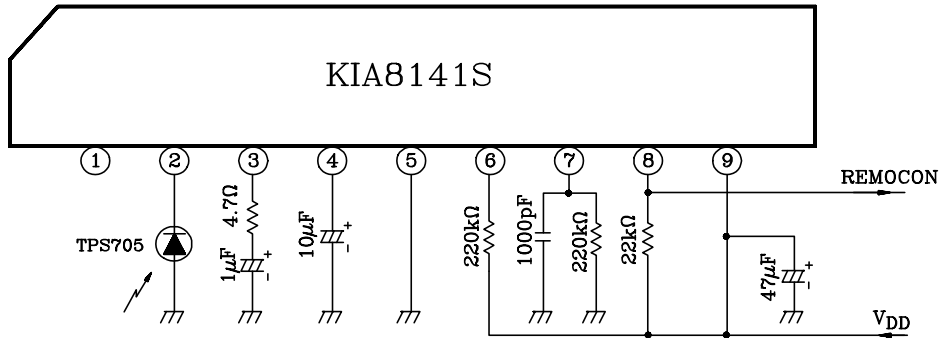

- Example KIC9243F application circuit.

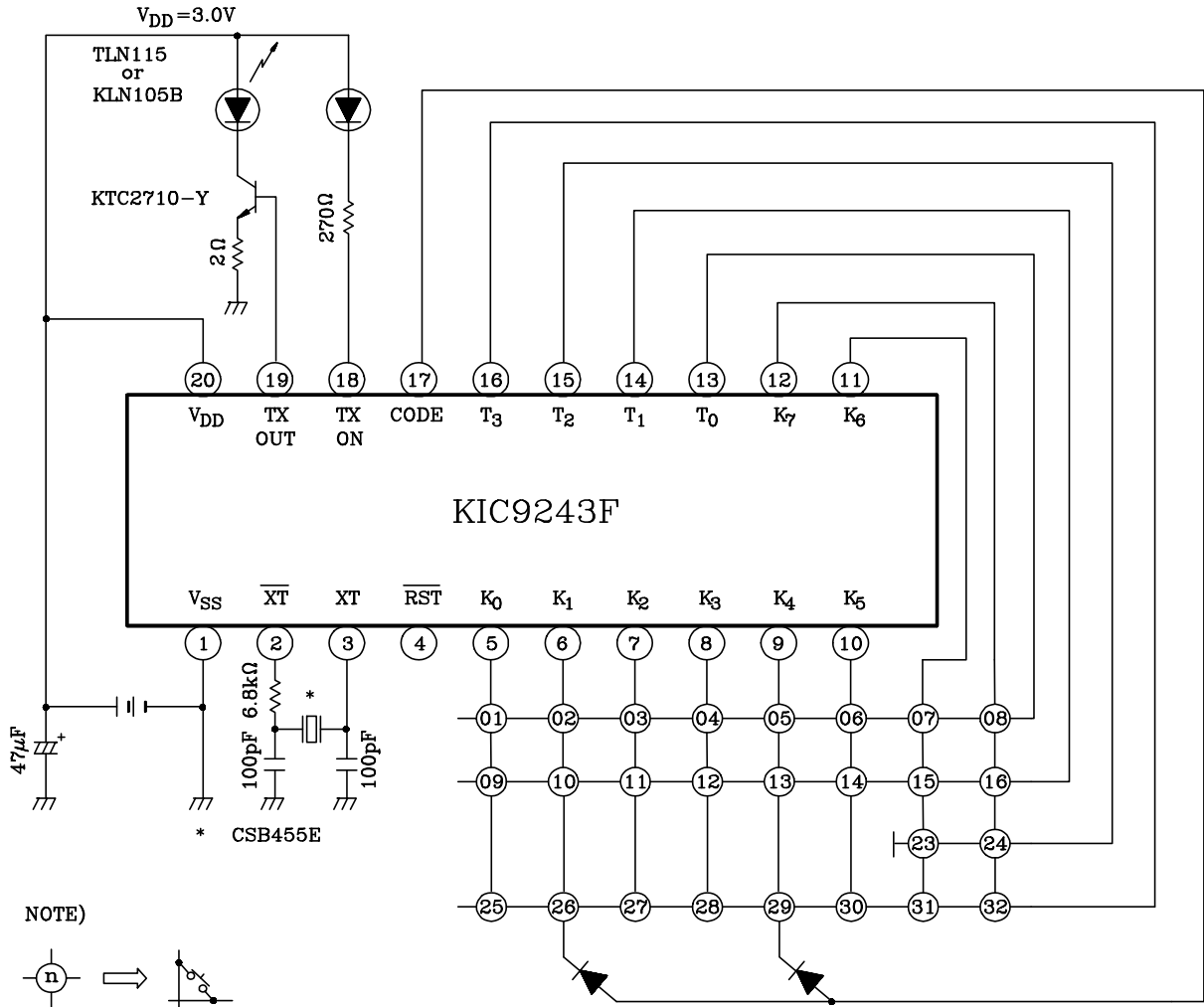

- The system code of KIC9319F-002 is "92H". Other system code is invalid.

# KIC9319F-002

