



GaAs INTEGRATED CIRCUIT

UPG2150T5L

GaAs MMIC SP3T SWITCH FOR BLUETOOTH & 802.11b/g

DESCRIPTION

The uPG2150T5L is a GaAs MMIC SP3T switch for Bluetooth & wireless LAN. The device can operate from 500MHz to 2.5GHz, having the low insertion loss and high isolation.

FEATURES

- Operating frequency : $f = 0.5$ to 2.5 GHz
- Low insertion loss : $L_{INS} = 0.5$ dB TYP. @ $f = 2.5$ GHz, ANT to RF1,RF2
0.6dB TYP. @ $f = 2.5$ GHz, ANT to RF3
- Handling power : $P_{in(1dB)} = +31$ dBm TYP. @ $f = 2.5$ GHz, ANT to RF1,RF2
+25 dBm TYP. @ $f = 2.5$ GHz, ANT to RF3
- Control voltage : $V_{cont} = +2.85$ V/0 V
- High isolation : ISL = 35dB TYP. @ $f = 2.5$ GHz, ANT to RF3 (ON)
18dB TYP. @ $f = 2.5$ GHz, ANT to RF1,2(ON)
- 12-pin plastic TSQFN package ($2.0 \times 2.0 \times 0.37$ mm)

APPLICATION

- Bluetooth & 802.11b/g

ORDERING INFORMATION

Part Number	Package	Marking	Supplying Form
uPG2150T5L-E2-A	12-pin plastic TSQFN	2150	<ul style="list-style-type: none"> • Embossed tape 8 mm wide • Pin 10,11,12 face the perforation side of the tape • Qty 3 kpcs/reel

Remark To order evaluation samples, contact your nearby sales office.

Part number for sample order: uPG2150T5L

Caution Observe precautions when handling because these devices are sensitive to electrostatic discharge.

The information in this document is subject to change without notice. Before using this document, please confirm that this is the latest version.

PIN CONNECTIONS AND INTERNAL BLOCK DIAGRAM

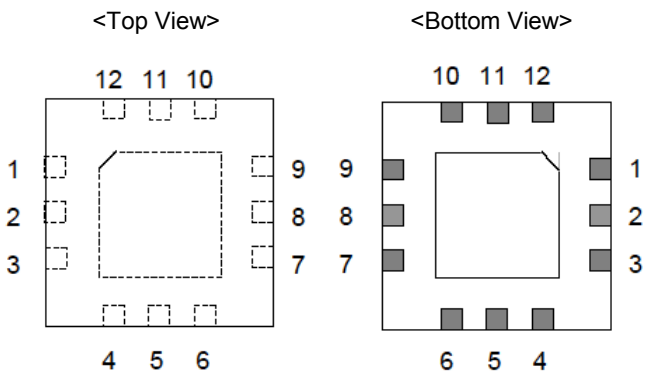

Pin No.	Pin Name
1	ANT
2	GND
3	Vcont2
4	RF2
5	GND
6	RF3
7	Vcont3
8	GND
9	Vcont1
10	RF1
11	GND
12	GND

TRUTH TABLE

V _{cont1}	V _{cont2}	V _{cont3}	ANT-RF1	ANT-RF2	ANT-RF3
2.3 to 3.6 V	0 ± 0.2 V	0 ± 0.2 V	ON	OFF	OFF
0 ± 0.2 V	2.3 to 3.6 V	0 ± 0.2 V	OFF	ON	OFF
0 ± 0.2 V	0 ± 0.2 V	2.3 to 3.6 V	OFF	OFF	ON

ABSOLUTE MAXIMUM RATINGS (T_A = +25°C, unless otherwise specified)

Parameter	Symbol	Ratings	Unit
Switch Control Voltage	V _{cont}	-6.0 to +6.0 ^{Note 1}	V
Input Power@ Ant to RF1,2	P _{in}	+34	dBm
Input Power@ Ant to RF3	P _{in}	+28	dBm
Operating Ambient Temperature	T _A	-45 to +85	°C
Storage Temperature	T _{stg}	-55 to +150	°C

Notes 1. |V_{cont1} - V_{cont2}| ≤ 6.0 V

2. Mounted on double-sided copper-clad 50 × 50 × 1.6 mm epoxy glass PWB, T_A = +85°C

RECOMMENDED OPERATING RANGE (TA = +25°C)

Parameter	Symbol	MIN.	TYP.	MAX.	Unit
Operating Frequency	f	0.5	-	2.5	GHz
Switch Control Voltage (H)	V _{cont (H)}	2.3	2.85	3.6	V
Switch Control Voltage (L)	V _{cont (L)}	-0.2	0	0.2	V

ELECTRICAL CHARACTERISTICS (TA = +25°C, V_{cont} = 2.85V/0 V, Zo = 50 Ω, DC blocking capacitors value: 56 pF, Each port, unless otherwise specified)

Parameter	Symbol	Pass	Test Conditions	MIN.	TYP.	MAX.	Unit
Insertion Loss	L _{ins}	ANT to RF1,2	f = 0.5 to 1.0GHz	-	0.40	0.55	dB
			f = 1.0 to 2.0GHz	-	0.45	0.60	dB
			f = 2.0 to 2.5GHz	-	0.50	0.65	dB
		ANT to RF3	f = 0.5 to 1.0GHz	-	0.45	0.60	dB
			f = 1.0 to 2.0GHz	-	0.55	0.70	dB
			f = 2.0 to 2.5GHz	-	0.60	0.75	dB
Isolation	ISL	ANT to RF3 OFF @ANT to RF1,2 ON RF1 to RF3 OFF @ANT-RF1ON	f = 0.5 to 1.0GHz	29	32	-	dB
			f = 1.0 to 2.0GHz	30	35		dB
			f = 2.0 to 2.5GHz	30	35		dB
		ANT to RF1 OFF @ANT to RF2,3 ON ANT to RF2 OFF @ANT to RF1,3 ON	f = 0.5 to 1.0GHz	23	26	-	dB
			f = 1.0 to 2.0GHz	17	20		dB
			f = 2.0 to 2.5GHz	15	18		dB
Input Return Loss	RL _{in}	ANT to RF1,2,3	f = 0.5 to 2.5GHz	15	20	-	dB
Output Return Loss	RL _{out}	ANT to RF1,2,3	f = 0.5 to 2.5GHz	15	20	-	dB
Switch Control Current	I _{cont}	ANT to RF1,2,3	RF Non	-	0.1	1.0	μA
Input Power at 1dB Compression Point	P _{in (1 dB)}	ANT to RF1,2,	f = 1.0 GHz	28	31	-	dBm
			f = 2.0 GHz				
			f = 2.5 GHz				
		ANT to RF3	f = 1.0 GHz	20	25	-	dBm
			f = 2.0 GHz				
			f = 2.5 GHz				
Switch Control Speed	t _{sw}	ANT to RF1,2,3	-	-	50	-	ns

EVALUATION CIRCUIT

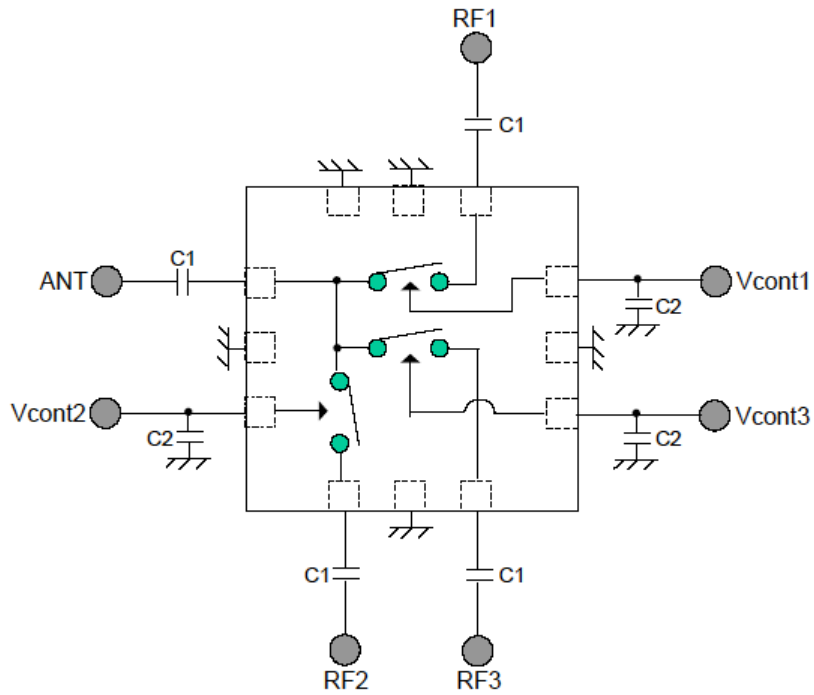

C1 : 56 pF, C2 : 1000pF

The application circuits and their parameters are for reference only and are not intended for use in actual design-ins.

PACKAGE DIMENSIONS

12-PIN PLASTIC TSQFN (UNIT: mm)

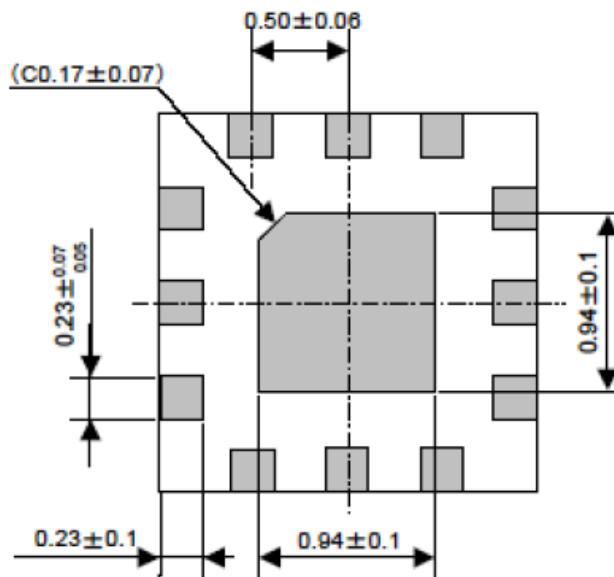
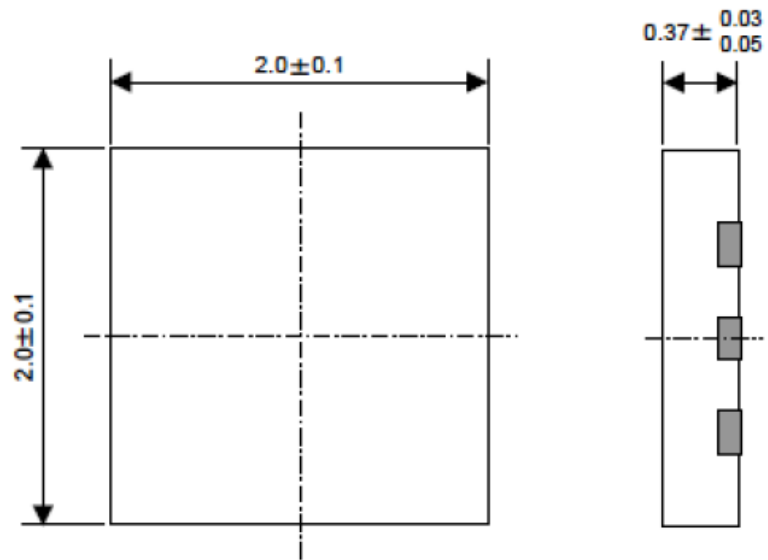

RECOMMENDED SOLDERING CONDITIONS

This product should be soldered and mounted under the following recommended conditions. For soldering methods and conditions other than those recommended below, contact your nearby sales office.

Soldering Method	Soldering Conditions	Condition Symbol
Infrared Reflow	Peak temperature (package surface temperature) : 260°C or below Time at peak temperature : 10 seconds or less Time at temperature of 220°C or higher : 60 seconds or less Preheating time at 120 to 180°C : 120±30 seconds Maximum number of reflow processes : 3 times Maximum chlorine content of rosin flux (% mass) : 0.2%(Wt.) or below	IR260
VPS	Peak temperature (package surface temperature) : 215°C or below Time at temperature of 200°C or higher : 25 to 40 seconds Preheating time at 120 to 150°C : 30 to 60 seconds Maximum number of reflow processes : 3 times Maximum chlorine content of rosin flux (% mass) : 0.2%(Wt.) or below	VP215
Wave Soldering	Peak temperature (molten solder temperature) : 260°C or below Time at peak temperature : 10 seconds or less Preheating temperature (package surface temperature) : 120°C or below Maximum number of flow processes : 1 time Maximum chlorine content of rosin flux (% mass) : 0.2%(Wt.) or below	WS260
Partial Heating	Peak temperature (pin temperature) : 350°C or below Soldering time (per side of device) : 3 seconds or less Maximum chlorine content of rosin flux (% mass) : 0.2%(Wt.) or below	HS350

Caution Do not use different soldering methods together (except for partial heating).

Subject: Compliance with EU Directives

CEL certifies, to its knowledge, that semiconductor and laser products detailed below are compliant with the requirements of European Union (EU) Directive 2002/95/EC Restriction on Use of Hazardous Substances in electrical and electronic equipment (RoHS) and the requirements of EU Directive 2003/11/EC Restriction on Penta and Octa BDE.

CEL Pb-free products have the same base part number with a suffix added. The suffix –A indicates that the device is Pb-free. The –AZ suffix is used to designate devices containing Pb which are exempted from the requirement of RoHS directive (*). In all cases the devices have Pb-free terminals. All devices with these suffixes meet the requirements of the RoHS directive.

This status is based on CEL’s understanding of the EU Directives and knowledge of the materials that go into its products as of the date of disclosure of this information.

Restricted Substance per RoHS	Concentration Limit per RoHS (values are not yet fixed)	Concentration contained in CEL devices	
		-A	-AZ
Lead (Pb)	< 1000 PPM	Not Detected	(*)
Mercury	< 1000 PPM	Not Detected	
Cadmium	< 100 PPM	Not Detected	
Hexavalent Chromium	< 1000 PPM	Not Detected	
PBB	< 1000 PPM	Not Detected	
PBDE	< 1000 PPM	Not Detected	

If you should have any additional questions regarding our devices and compliance to environmental standards, please do not hesitate to contact your local representative.

Important Information and Disclaimer: Information provided by CEL on its website or in other communications concerning the substance content of its products represents knowledge and belief as of the date that it is provided. CEL bases its knowledge and belief on information provided by third parties and makes no representation or warranty as to the accuracy of such information. Efforts are underway to better integrate information from third parties. CEL has taken and continues to take reasonable steps to provide representative and accurate information but may not have conducted destructive testing or chemical analysis on incoming materials and chemicals. CEL and CEL suppliers consider certain information to be proprietary, and thus CAS numbers and other limited information may not be available for release.

In no event shall CEL’s liability arising out of such information exceed the total purchase price of the CEL part(s) at issue sold by CEL to customer on an annual basis.

See CEL Terms and Conditions for additional clarification of warranties and liability.