

Insulated Gate Bipolar Transistor (Warp 2 Speed IGBT), 100 A

SOT-227
FEATURES

- Ultrafast: Optimized for minimum saturation voltage and speed 0 to 40 kHz in hard switching, > 200 kHz in resonant mode
- Very low conduction and switching losses
- Fully isolated package (2500 V AC/RMS)
- Very low internal inductance (≤ 5 nH typical)
- Industry standard outline
- UL approved file E78996
- Compliant to RoHS directive 2002/95/EC
- Designed and qualified for industrial market

**RoHS
COMPLIANT**
PRODUCT SUMMARY

V_{CES}	600 V
I_C DC	100 A
$V_{CE(on)}$ at 100 A, 25 °C	1.8 V

BENEFITS

- Designed for increased operating efficiency in power conversion: PFC, UPS, SMPS, welding, induction heating
- Lower overall losses available at frequencies ≥ 20 kHz
- Easy to assemble and parallel
- Direct mounting to heatsink
- Lower EMI, requires less snubbing
- Plug in compatible with other SOT-227 packages

ABSOLUTE MAXIMUM RATINGS

PARAMETER	SYMBOL	TEST CONDITIONS	MAX.	UNITS
Collector to emitter breakdown voltage	V_{CES}		600	V
Continuous collector current	I_C	$T_C = 25\text{ °C}$	100	A
		$T_C = 100\text{ °C}$	50	
Pulsed collector current	I_{CM}		200	
Clamped inductive load current	I_{LM}	Repetitive rating: $V_{GE} = 20$ V; pulse width limited by maximum junction temperature (fig. 20)	200	
Gate to emitter voltage	V_{GE}		± 20	V
RMS isolation voltage	V_{ISOL}	Any terminal to case, $t = 1$ minute	2500	
Maximum power dissipation	P_D	$T_C = 25\text{ °C}$	250	W
		$T_C = 100\text{ °C}$	100	
Operating junction and storage temperature range	T_J, T_{Stg}		- 55 to + 150	°C
Mounting torque		6 to 32 or M3 screw	12 (1.3)	lbf · in (N · m)

THERMAL AND MECHANICAL SPECIFICATIONS

PARAMETER	SYMBOL	TYP.	MAX.	UNITS
Junction to case, IGBT	R_{thJC}	-	0.50	°C/W
Thermal resistance, junction to case, diode	R_{thJC}	-	1.0	
Case to sink, flat, greased surface	R_{thCS}	0.05	-	
Weight of module		30	-	g

ELECTRICAL SPECIFICATIONS (T _J = 25 °C unless otherwise specified)						
PARAMETER	SYMBOL	TEST CONDITIONS	MIN.	TYP.	MAX.	UNITS
Collector to emitter breakdown voltage	V _{(BR)CES}	V _{GE} = 0 V, I _C = 250 μA	600	-	-	V
Temperature coefficient of breakdown voltage	ΔV _{(BR)CES} /ΔT _J	V _{GE} = 0 V, I _C = 1.0 mA	-	0.36	-	V/°C
Collector to emitter saturation voltage	V _{CE(on)}	V _{GE} = 15 V, I _C = 50 A	-	1.49	2.1	V
		V _{GE} = 15 V, I _C = 100 A	-	1.80	-	
		V _{GE} = 15 V, I _C = 50 A, T _J = 150 °C	-	1.47	-	
Gate threshold voltage	V _{GE(th)}	V _{CE} = V _{GE} , I _C = 250 μA	3.0	-	6.0	
Temperature coefficient of threshold voltage	ΔV _{GE(th)} /ΔT _J	V _{CE} = V _{GE} , I _C = 250 μA	-	-7.6	-	mV/°C
Forward transconductance	g _{fe}	V _{CE} = 100 V, I _C = 50 A	34	52	-	S
Zero gate voltage collector current	I _{CES}	V _{GE} = 0 V, V _{CE} = 600 V	-	-	250	μA
		V _{GE} = 0 V, V _{CE} = 600 V, T _J = 150 °C	-	-	1.3	mA
Diode forward voltage drop	V _{FM}	I _C = 50 A	-	1.3	1.6	V
		I _C = 50 A, T _J = 150 °C	-	1.16	1.3	
Gate to emitter leakage current	I _{GES}	V _{GE} = ± 20 V	-	-	± 100	nA

SWITCHING CHARACTERISTICS (T _J = 25 °C unless otherwise specified)							
PARAMETER	SYMBOL	TEST CONDITIONS	MIN.	TYP.	MAX.	UNITS	
Total gate charge (turn-on)	Q _g	I _C = 50 A	-	430	640	nC	
Gate emitter charge (turn-on)	Q _{ge}	V _{CC} = 400 V	-	48	72		
Gate collector charge (turn-on)	Q _{gc}	V _{GE} = 15 V	-	130	190		
Turn-on delay time	t _{d(on)}	T _J = 25 °C I _C = 60 A, V _{CC} = 480 V V _{GE} = 15 V, R _g = 5.0 Ω energy losses include "tail" and diode reverse recovery	-	57	-	ns	
Rise time	t _r		-	80	-		
Turn-off delay time	t _{d(off)}		-	240	-		
Fall time	t _f		-	120	-		
Turn-on switching loss	E _{on}	T _J = 25 °C I _C = 60 A, V _{CC} = 480 V V _{GE} = 15 V, R _g = 5.0 Ω energy losses include "tail" and diode reverse recovery	-	0.41	-	mJ	
Turn-off switching loss	E _{off}		-	2.51	-		
Total switching loss	E _{ts}		-	2.92	4.4		
Turn-on delay time	t _{d(on)}	T _J = 150 °C I _C = 60 A, V _{CC} = 480 V V _{GE} = 15 V, R _g = 5.0 Ω energy losses include "tail" and diode reverse recovery	-	57	-	ns	
Rise time	t _r		-	80	-		
Turn-off delay time	t _{d(off)}		-	380	-		
Fall time	t _f		-	170	-		
Total switching loss	E _{ts}		-	4.78	-	mJ	
Internal emitter inductance	L _E		-	2.0	-	nH	
Input capacitance	C _{ies}	V _{GE} = 0 V	-	7400	-	pF	
Output capacitance	C _{oes}	V _{CC} = 30 V	-	730	-		
Reverse transfer capacitance	C _{res}	f = 1.0 MHz	-	90	-		
Diode reverse recovery time	t _{rr}	T _J = 25 °C	See fig. 13	-	90	140	ns
		T _J = 125 °C		-	120	180	
Diode peak reverse recovery current	I _{rr}	T _J = 25 °C	See fig. 14	-	7.3	11	A
		T _J = 125 °C		-	11	16	
Diode reverse recovery charge	Q _{rr}	T _J = 25 °C	See fig. 15	-	360	550	nC
		T _J = 125 °C		-	780	1200	
Diode peak rate of fall recovery during t _b	dl _(rec) M/dt	T _J = 25 °C	See fig. 16	-	370	-	A/μs
		T _J = 125 °C		-	220	-	

Insulated Gate Bipolar Transistor (Warp 2 Speed IGBT), 100 A

Vishay Semiconductors

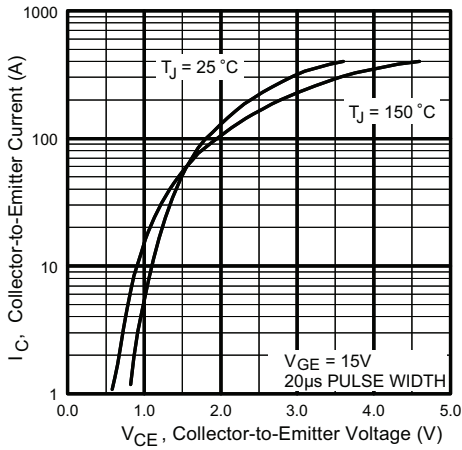

Fig. 1 - Typical Output Characteristics

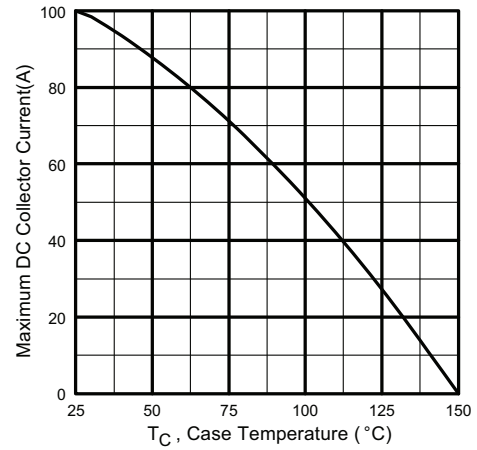

Fig. 3 - Maximum Collector Current vs. Case Temperature

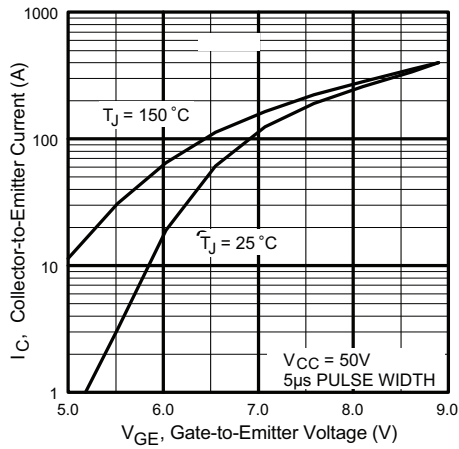

Fig. 2 - Typical Transfer Characteristics

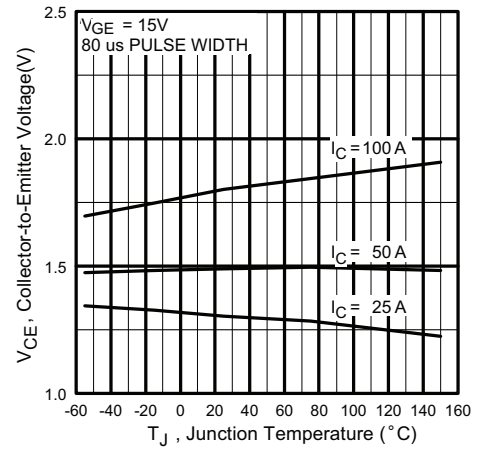

Fig. 4 - Typical Collector to Emitter Voltage vs. Junction Temperature

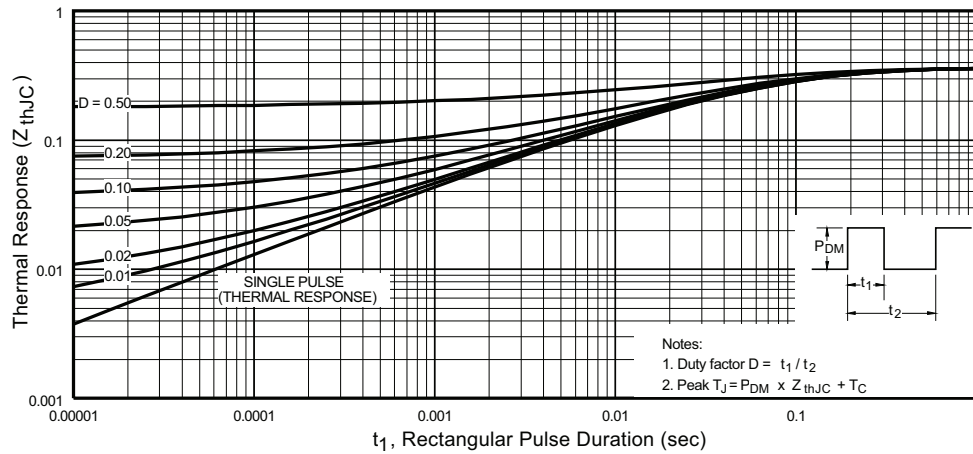

Fig. 5 - Maximum Effective Transient Thermal Impedance, Junction to Case

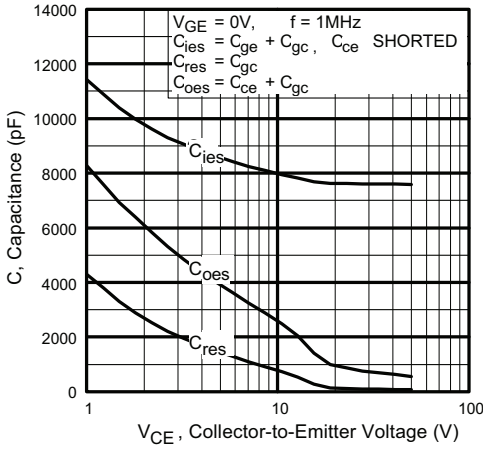

Fig. 6 - Typical Capacitance vs. Collector to Emitter Voltage

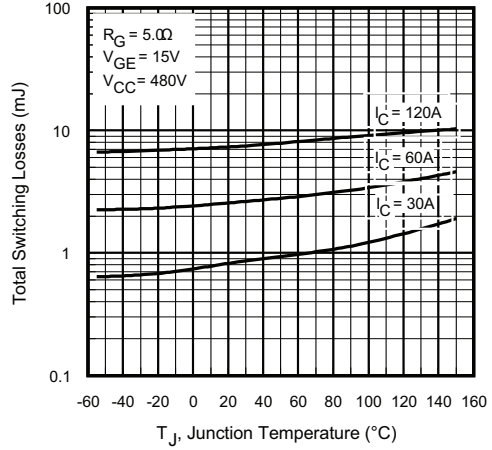

Fig. 9 - Typical Switching Losses vs. Junction Temperature

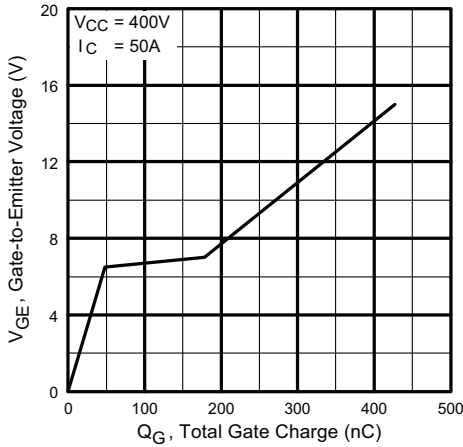

Fig. 7 - Typical Gate Charge vs. Gate to Emitter Voltage

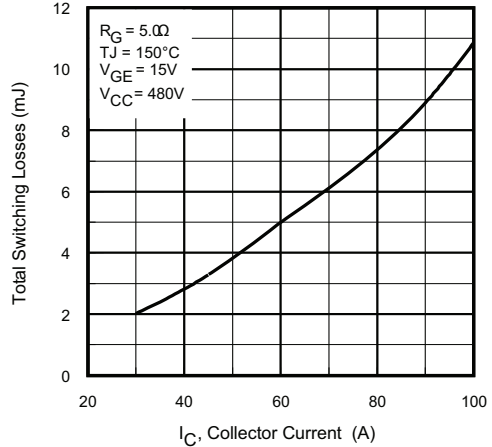

Fig. 10 - Typical Switching Losses vs. Collector to Emitter Current

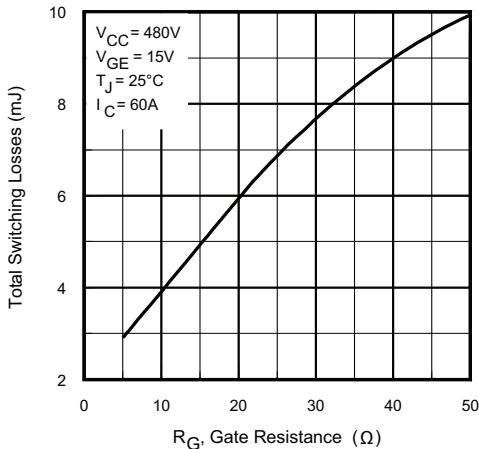

Fig. 8 - Typical Switching Losses vs. Gate Resistance

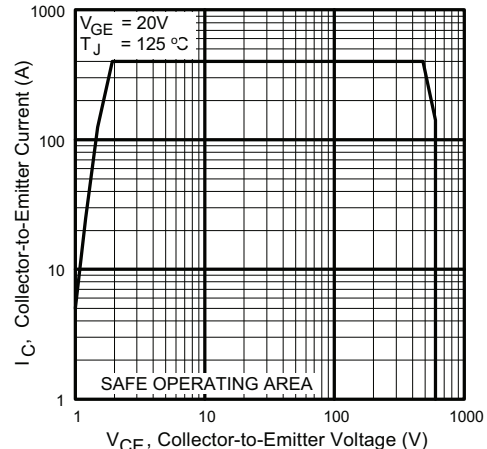

Fig. 11 - Turn-Off SOA

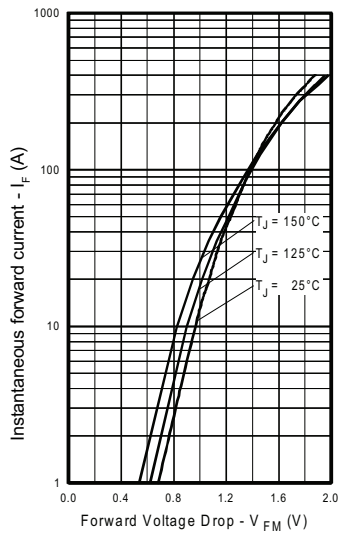

Fig. 12 - Typical Forward Voltage Drop vs. Instantaneous Forward Current

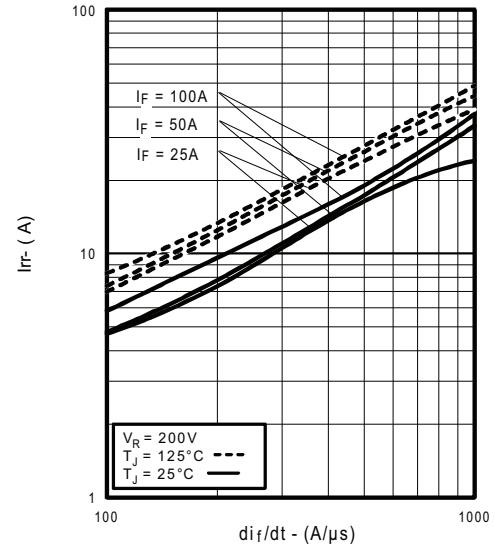

Fig. 14 - Typical Recovery Current vs. di_f/dt

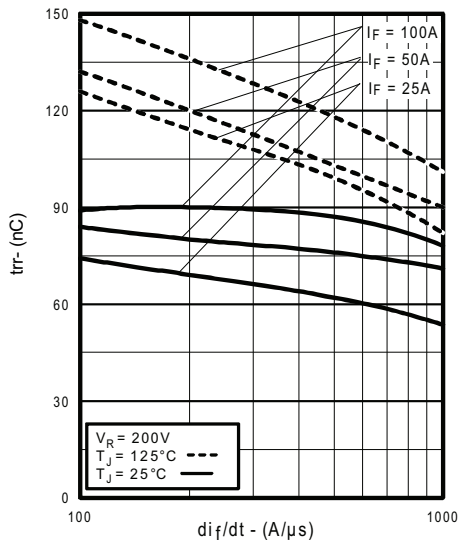

Fig. 13 - Typical Reverse Recovery vs. di_f/dt

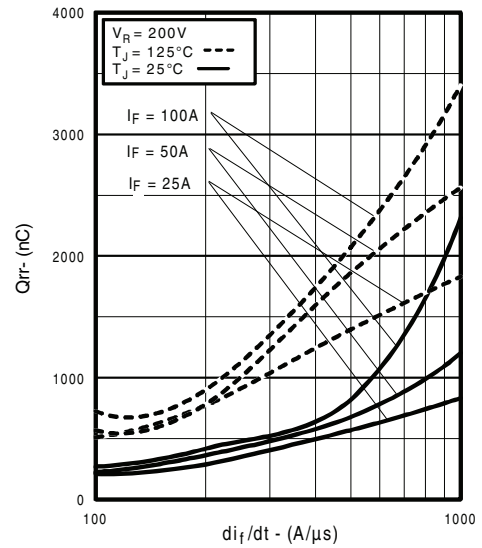

Fig. 15 - Typical Stored Charge vs. di_f/dt

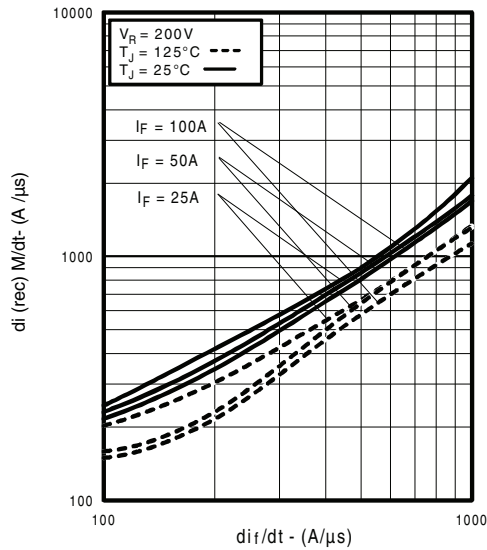

Fig. 16 - Typical $dI_{(rec)M}/dt$ vs. dI_F/dt

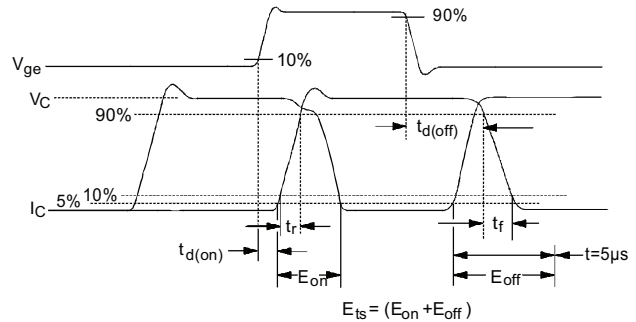

Fig. 17b - Test Waveforms for Circuit of Fig. 17a, Defining E_{off} , $t_{d(off)}$, t_f

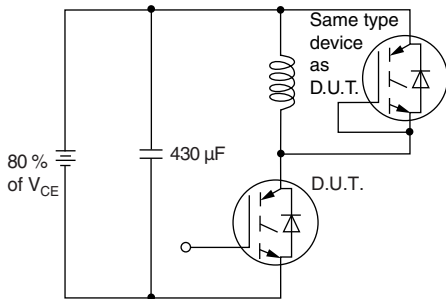

Fig. 17a - Test Circuit for Measurement of I_{LM} , E_{on} , $E_{off}(\text{diode})$, t_{rr} , Q_{rr} , I_{rr} , $t_{d(on)}$, t_r , $t_{d(off)}$, t_f

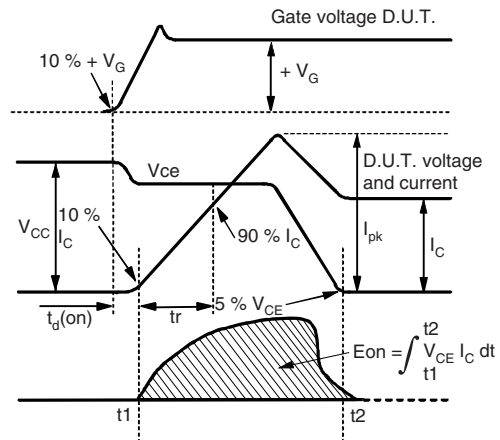

Fig. 17c - Test Waveforms for Circuit of Fig. 17a, Defining E_{on} , $t_{d(on)}$, t_r

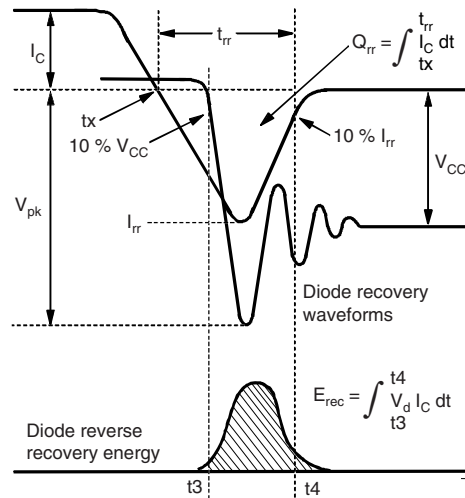
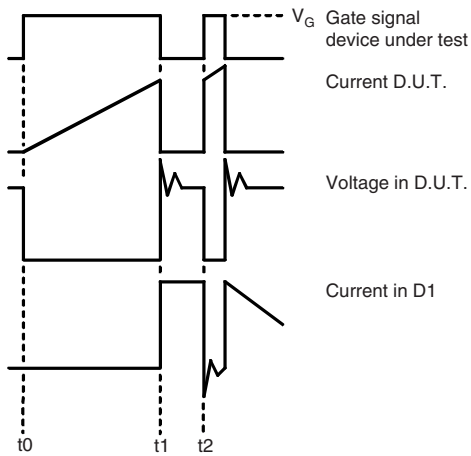

 Fig. 17d - Test Waveforms for Circuit of Fig. 17a,
 Defining E_{rec} , t_{tr} , Q_{rr} , I_{rr}

Fig. 17e - Macro Waveforms for Figure 17a's Test Circuit

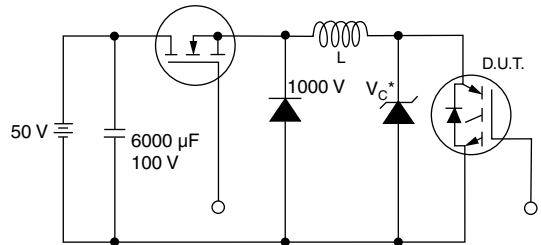

Fig. 18a - Clamped Inductive Load Test Circuit

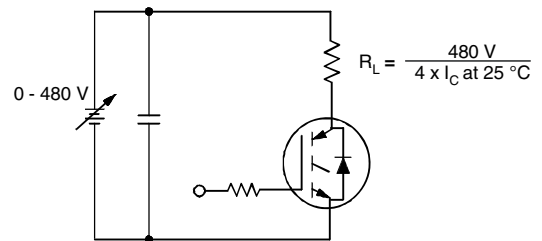

Fig. 18b - Pulsed Collector Current Test Circuit

GA100NA60UP

Vishay Semiconductors

Insulated Gate Bipolar Transistor
(Warp 2 Speed IGBT), 100 A



ORDERING INFORMATION TABLE

Device code	G	A	100	N	A	60	U	P
	①	②	③	④	⑤	⑥	⑦	⑧

- 1** - Device:
G = IGBT
- 2** - Silicon technology:
A = Generation 4 IGBT, Generation 2 HEXFRED®
- 3** - Current rating (100 = 100 A)
- 4** - N = High side chopper
- 5** - SOT-227
- 6** - Voltage rating (60 = 600 V)
- 7** - U = Ultrafast with matching diode
- 8** -
 - None = Standard production
 - P = Lead (Pb)-free

CIRCUIT CONFIGURATION

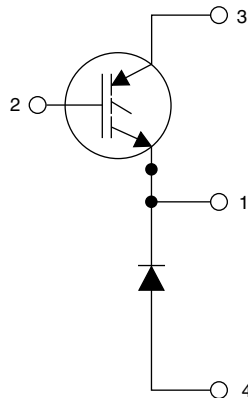

LINKS TO RELATED DOCUMENTS	
Dimensions	www.vishay.com/doc?95036
Packaging information	www.vishay.com/doc?95037

SOT-227

DIMENSIONS in millimeters (inches)

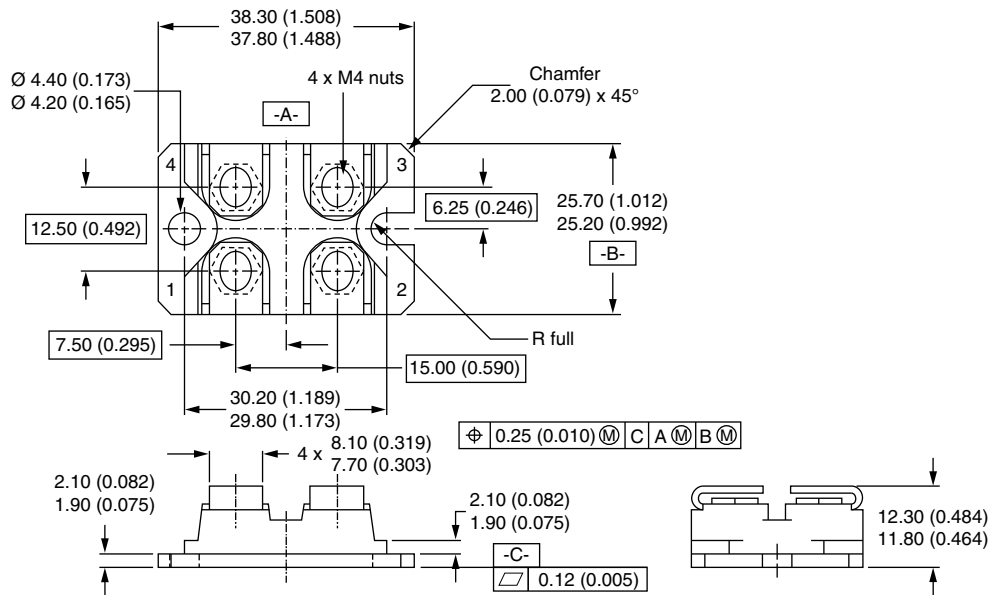

Notes

- Dimensioning and tolerancing per ANSI Y14.5M-1982
- Controlling dimension: millimeter



Disclaimer

ALL PRODUCT, PRODUCT SPECIFICATIONS AND DATA ARE SUBJECT TO CHANGE WITHOUT NOTICE TO IMPROVE RELIABILITY, FUNCTION OR DESIGN OR OTHERWISE.

Vishay Intertechnology, Inc., its affiliates, agents, and employees, and all persons acting on its or their behalf (collectively, "Vishay"), disclaim any and all liability for any errors, inaccuracies or incompleteness contained in any datasheet or in any other disclosure relating to any product.

Vishay makes no warranty, representation or guarantee regarding the suitability of the products for any particular purpose or the continuing production of any product. To the maximum extent permitted by applicable law, Vishay disclaims (i) any and all liability arising out of the application or use of any product, (ii) any and all liability, including without limitation special, consequential or incidental damages, and (iii) any and all implied warranties, including warranties of fitness for particular purpose, non-infringement and merchantability.

Statements regarding the suitability of products for certain types of applications are based on Vishay's knowledge of typical requirements that are often placed on Vishay products in generic applications. Such statements are not binding statements about the suitability of products for a particular application. It is the customer's responsibility to validate that a particular product with the properties described in the product specification is suitable for use in a particular application. Parameters provided in datasheets and/or specifications may vary in different applications and performance may vary over time. All operating parameters, including typical parameters, must be validated for each customer application by the customer's technical experts. Product specifications do not expand or otherwise modify Vishay's terms and conditions of purchase, including but not limited to the warranty expressed therein.

Except as expressly indicated in writing, Vishay products are not designed for use in medical, life-saving, or life-sustaining applications or for any other application in which the failure of the Vishay product could result in personal injury or death. Customers using or selling Vishay products not expressly indicated for use in such applications do so at their own risk and agree to fully indemnify and hold Vishay and its distributors harmless from and against any and all claims, liabilities, expenses and damages arising or resulting in connection with such use or sale, including attorneys fees, even if such claim alleges that Vishay or its distributor was negligent regarding the design or manufacture of the part. Please contact authorized Vishay personnel to obtain written terms and conditions regarding products designed for such applications.

No license, express or implied, by estoppel or otherwise, to any intellectual property rights is granted by this document or by any conduct of Vishay. Product names and markings noted herein may be trademarks of their respective owners.