

MIL-PRF-24758-21 Adapter for MIL-DTL-22992 Connectors

M24758 - 21 C 20

Basic No. _____
 Conduit Size Code, Table I _____
 Connector Dash No., Table II _____

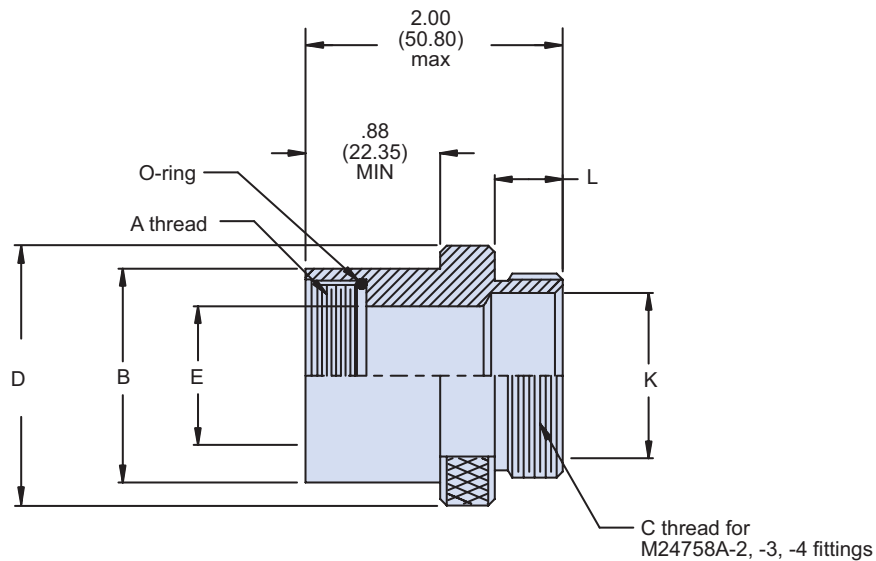

APPLICATION NOTES

1. Assembly identified with manufacturer's code identification number (Glenair, part number and classification code 490).
2. The M24758-21 adapter couples connectors listed in table II to M24758-2, M24758-3 or M24758-4 series fittings.
3. This adapter shall conform to military standard MIL-DTL-22992 connector.
4. Configuration of adapter may change based on the variance of diameters E and K.
5. Material / Finish:
Adapter, coupling nut, 316 / electroless nickel, matte finish, O-ring - silicone rubber.
6. Metric dimensions (mm) are indicated in parentheses.
7. See M24758-2, -3, -4 torque values for C thread.

**MIL-PRF-24758-21
Adapter for MIL-DTL-22992 Connectors**



**MIL-PRF
24758A**

TABLE I				
CONDUIT SIZE CODE	C CLASS - 2A THREAD	L +.03 (.76) -.00	K DIA MIN	D DIA REF
A	.438-28 UNEF	.21 (5.25)	.245 (6.22)	.88 (22.35)
B	.688-24 UNEF	.25 (6.35)	.495 (12.57)	1.13 (28.70)
C	.938-20 UNEF	.31 (7.87)	.745 (18.92)	1.38 (35.05)
D	1.250-18 UNEF	.37 (9.40)	.995 (25.27)	1.69 (42.93)
E	1.563-18 UNEF	.37 (9.40)	1.245 (31.62)	2.00 (50.80)
F	1.875-16 UN	.43 (10.92)	1.495 (37.97)	2.31 (58.67)
G	2.375-16 UN	.43 (10.92)	1.995 (50.67)	2.94 (74.68)
H	2.875-16 UN	.43 (10.92)	2.495 (63.37)	3.44 (87.38)
J	.563-24 UNEF	.25 (6.35)	.370 (9.40)	.94 (23.88)
K	.813-20 UNEF	.31 (7.87)	.620 (15.75)	1.19 (30.23)
L	3.375-16 UN	.43 (10.92)	2.995 (76.07)	3.94 (100.08)

TABLE II: CONNECTOR DASH NUMBERS AND ADAPTER DIMENSIONS					
CONN DASH NO.	MIL-DTL-22992	A LEFT HAND CLASS - 2B THREAD	B DIA MAX	E DIA REF	A THREAD RECOMMENDED TORQUE ±5 IN. POUNDS
12	12	.750-20 UNEF	.858 (21.79)	.60 (15.24)	108
14	14	.875-20 UNEF	.984 (24.99)	.72 (18.29)	116
16	16	1.000-20 UNEF	1.112 (28.45)	.84 (21.34)	116
18	18	1.125-18 UNEF	1.218 (30.94)	.94 (23.88)	116
20	20	1.250-18 UNEF	1.345 (34.16)	1.10 (27.94)	136
22	22	1.375-18 UNEF	1.468 (37.29)	1.20 (30.48)	136
24	24	1.625-18 UNEF	1.593 (40.46)	1.44 (36.58)	136
28	28	1.875-16 UN	1.969 (50.01)	1.69 (42.93)	148
32	32	2.062-16 UNS	2.219 (56.34)	1.88 (47.75)	148
36	36	2.312-16 UN	2.469 (62.71)	2.13 (54.10)	148
40	40	2.625-16 UN	2.719 (69.06)	2.44 (61.98)	164
44	44	2.875-16 UN	2.969 (75.41)	2.75 (68.85)	164
48	48	3.125-16 UN	3.219 (81.76)	2.88 (73.15)	164