

Product General Specification

1. General Description

The LM151X3 is a Color Active Matrix Liquid Crystal Display with an integral Cold Cathode Fluorescent Lamp(CCFL) backlight system. The matrix employs a-Si Thin Film Transistor as the active element. It is a transmissive type display operating in the normally white mode. This TFT-LCD has a 15.1 inches diagonally measured active display area with XGA resolution(768 vertical by 1024 horizontal pixel array). Each pixel is divided into Red, Green and Blue sub-pixels or dots which are arranged in vertical stripes. Gray scale or the brightness of the sub-pixel color is determined with a 8-bit gray scale signal for each dot, thus, presenting a palette of more than 16,777,216 colors.

The LM151X3 has been designed to apply the TMDS interface method.

The LM151X3 LCD is intended to support applications where high brightness, wide viewing angle, high color saturation, and high color depth are very important. In combination with the vertical arrangement of the sub-pixels, the LM151X3 characteristics provide an excellent flat panel display for office automation products such as monitors.

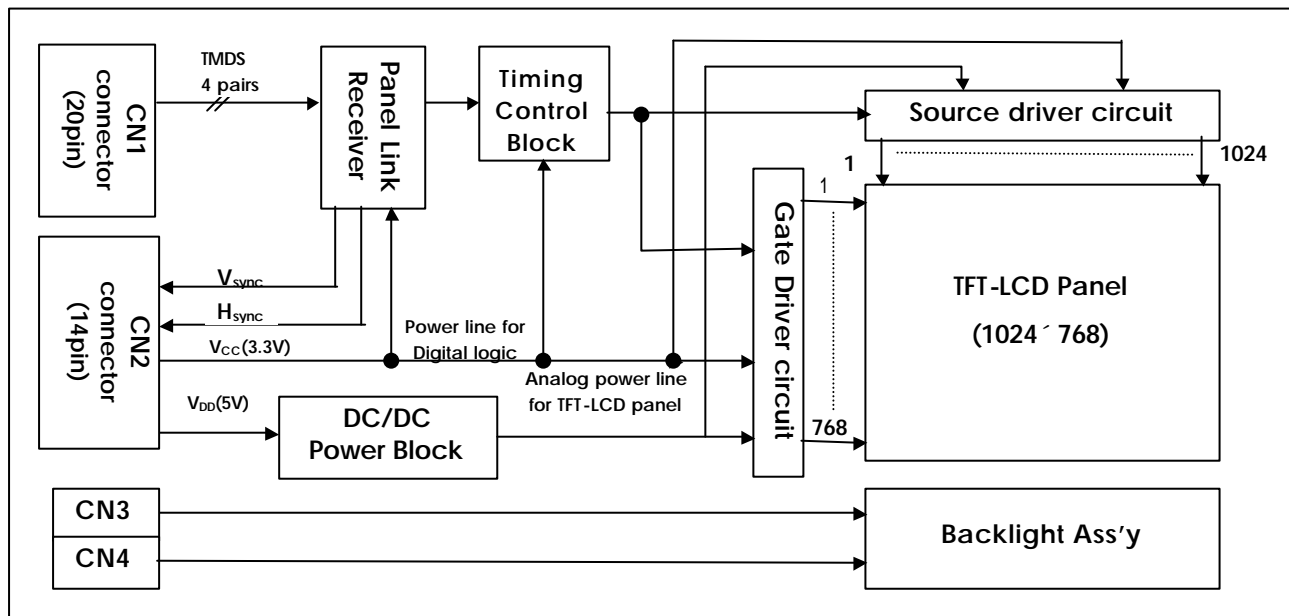

General Features

Active screen size	15.1 inches(307.2 x 230.4mm) diagonal
Outline dimensions	352.0(H) × 263.5(V) × 16.0(D) mm (typ) without user connector
Pixel pitch	0.300 mm × 0.300 mm
Pixel format	1024 horiz. By 768 vert. pixels
	RGB stripe arrangement
Color depth	8-bit, 16,777,216 colors
Luminance,White	250 cd/m ² (typ)
Power Consumption	2.1Watts Logic / 9.7Watts CCFL (typ. With 256 Gray Pattern)
Weight	1500g (typ)
Display operating mode	Transmissive mode, normally white
Surface treatments	Hard coating(3H), Anti-glare treatment of the front polarizer

Product General Specification

2. Electrical Specifications

2-1. Electrical Characteristics

The LM151X3 requires two power inputs. One is employed to power the LCD electronics and to drive the TFT array and liquid crystal. The second input which powers the CCFL, is typically generated by an inverter. The inverter is an external unit to the LCD.

Table 1 ELECTRICAL CHARACTERISTICS:

Parameter	Symbol	Values			Units	Notes
		Min.	Typ.	Max.		
MODULE:						
Power Supply Input Voltage	V_{CC}	3.15	3.3	3.45	Vdc	
	V_{DD}	4.5	5.0	5.5	Vdc	
Power Supply Input Current	I_{CC}	0.20	0.23	0.26	A	1
	I_{DD}	0.20	0.25	0.30	A	
Power Consumption	P_c	-	2.1	3.0	Watts	1
LAMP						
Operating Voltage	V_{BL}	585(9mA)	605(8mA)	720(3mA)	V_{RMS}	2
Operating Current	I_{BL}	3.0	8.0	9.0	mA	
Established Starting Voltage	V_{BS}					3
at 25		-	-	1020	V_{RMS}	
at 0		-	-	1430	V_{RMS}	
Operating Frequency	f_{BL}	30	50	60	KHZ	4
Discharge Stabilization Time	T_s	-	-	3	Minutes	5
Power Consumption	P_{BL}	-	9.7	10.6	Watts	6
Life Time					Hrs	7
		30000	-	-		8mArms

Notes: 1. The specified current and power consumption are under the $V_{DD} = 5.0V$, $V_{CC} = 3.3V$, 25 and $f_v = 60Hz$ condition

Power supply input current and Typ. Power consumption is measured while 256 gray pattern is displayed

The max. power consumption is measured while Vertical 2line(full white) by 2line(full black) pattern is displayed.

- The variance of the voltage is $\pm 10\%$.
- The voltage above V_s should be applied to the lamps for more than 1second for start-up. Otherwise, the lamps may not be turned on.
- The output of the inverter must have symmetrical(negative and positive) voltage waveform and symmetrical current waveform.(Unsymmetrical ratio is less than 10%) Please do not use the inverter which has unsymmetrical voltage and unsymmetrical current and spike wave.
Lamp frequency may produce interference with horizontal synchronous frequency and as a result this may cause beat on the display. Therefore lamp frequency shall be as away as possible from the horizontal synchronous frequency and from its harmonics in order to prevent interference.
- Let's define the brightness of the lamp after being lighted for 5 minutes as 100%.
 T_s is the time required for the brightness of the center of the lamp to be not less than 95%.
- The lamp power consumption shown above does not include loss of external inverter.
- The life time is determined as the time at which brightness of lamp is 50% compared to that of initial value at the typical lamp current on condition of continuous operating at 25 ± 2 .

Product General Specification
2-2. Interface Connections

This LCM has four interface connections, a 20 pin connector and a 14 pin connector are used for the module electronics and, two three pin connectors are used for the integral backlight system.

The electronics interface connector is a model DF19K-20P-1H(20 Pin connector) and the other model DF19L-14P-1H(14 Pin connector) manufactured by Hirose. The pin configuration for the connector is shown in the table below. (LCD Connector : DF19K-20P-1H and DF19L-14P-1H, Mating Connector : DF19G-20S-1C and DF19G-14S-1C.)

Table 2 MODULE CONNECTOR PIN CONFIGURATION

Pin	Symbol	I/O	Description	Pin	Symbol	I/O	Description
1	GND	INPUT	Ground	1	GND	INPUT	Ground
2	GND	INPUT	Ground	2	Vsync.	OUTPUT	Vsync.
3	Rx2+	INPUT	Plus Red TMDS signal	3	Hsync.	OUTPUT	Hsync.
4	Rx2-	INPUT	Minus Red TMDS signal	4	GND	INPUT	Ground
5	GND	INPUT	Ground	5			NC
6	Rx1+	INPUT	Plus Green TMDS signal	6			NC
7	Rx1-	INPUT	Minus Green TMDS signal	7			NC
8	GND	INPUT	Ground	8	GND	INPUT	Ground
9	Rx0+	INPUT	Plus Blue TMDS signal	9	VCC	INPUT	Logic Power +3.3V
10	Rx0-	INPUT	Minus Blue TMDS signal	10	VCC	INPUT	Logic Power +3.3V
11	GND	INPUT	Ground	11	VDD	INPUT	Analog Power +5V
12	RxC+	INPUT	Plus Main clock	12	VDD	INPUT	Analog Power +5V
13	RxC-	INPUT	Minus Main clock	13	VDD	INPUT	Analog Power +5V
14	GND	INPUT	Ground	14	GND	INPUT	Ground
15			NC				
16			NC				
17			NC				
18			NC				
19			NC				
20	GND	INPUT	Ground				

- Notes: 1. All GND(ground) pins should be connected together and to Vss which should also be connected to the LCD's metal frame.
 2. All V_{DD}(power input) pins should be connected together.

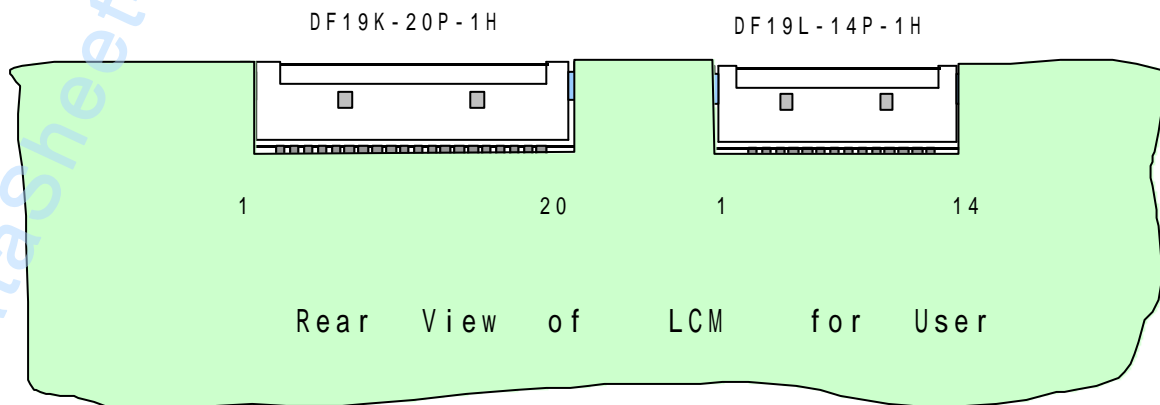

Product General Specification

The backlight interface connector is a model BHR-03VS-1, manufactured by JST. The mating connector part number is SM02(8.0)B-BHS-1-TB or equivalent. The pin configuration for the connector is shown in the table below.

Table 3 BACKLIGHT CONNECTOR PIN CONFIGURATION

Pin	Symbol	Description	Notes
1	HV	Lamp power input(High)	1
2	NC	No connect	
3	LV	Lamp power input(Low)	

Notes: 1. The input power terminal (High) is colored pink.

Product General Specification

< FRONT VIEW >

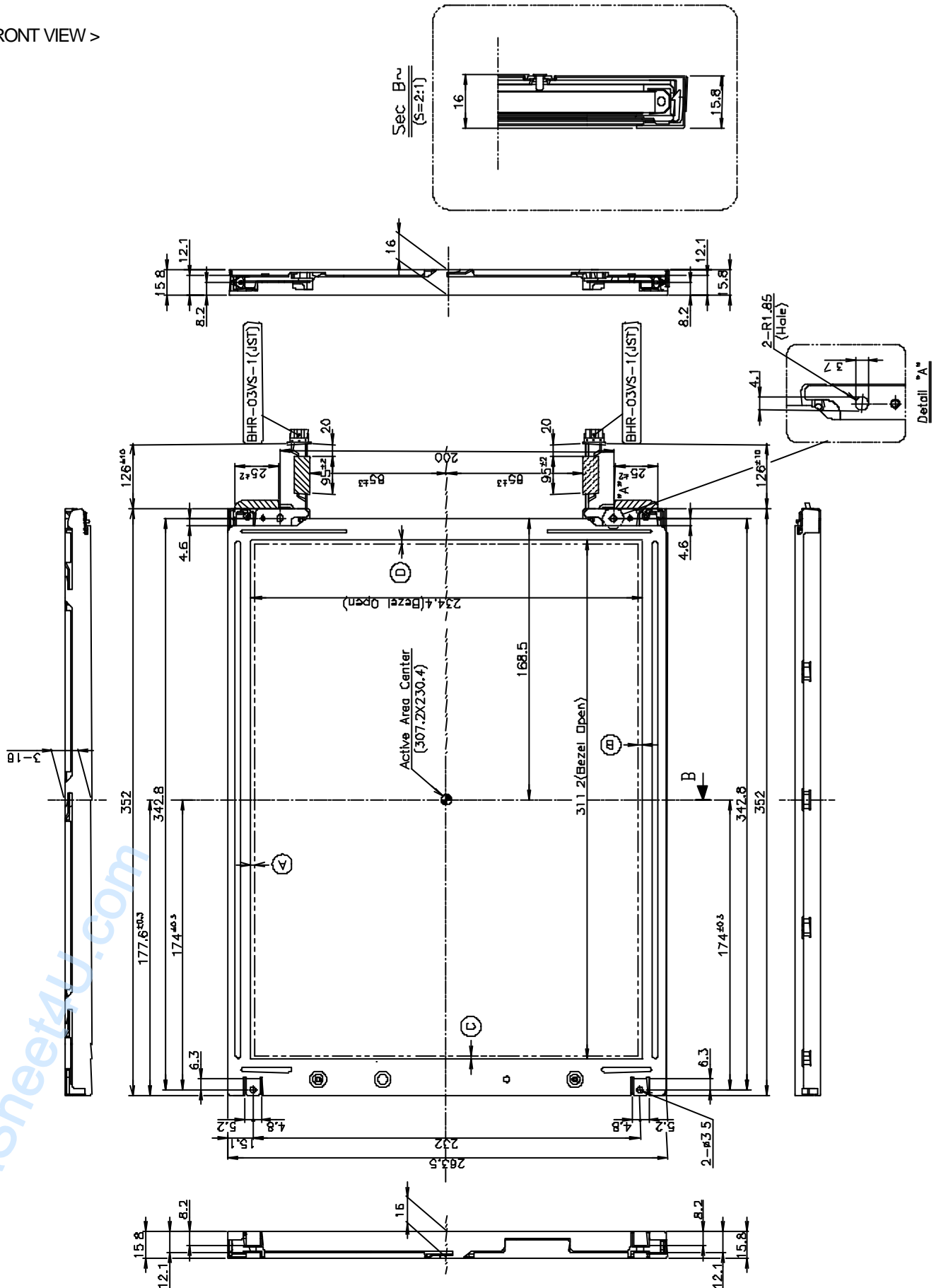

Product General Specification

< REAR VIEW >

NOTES

1. Unspecified tolerances to be ± 0.5
2. This drawing is only preliminary data and can be changed without previous notice
3. Gap between Top case and Glass is $D.2(+0.5/-0.2)$
4. Tilt and partial disposition tolerance of display area are as follow
 - 1) Y-Direction : $A-BI \leq 1.0$
 - 2) X-Direction : $IC-DI \leq 1.0$

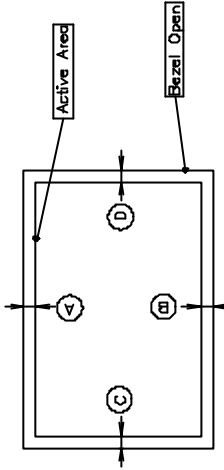

5. The same shape is same dimension.

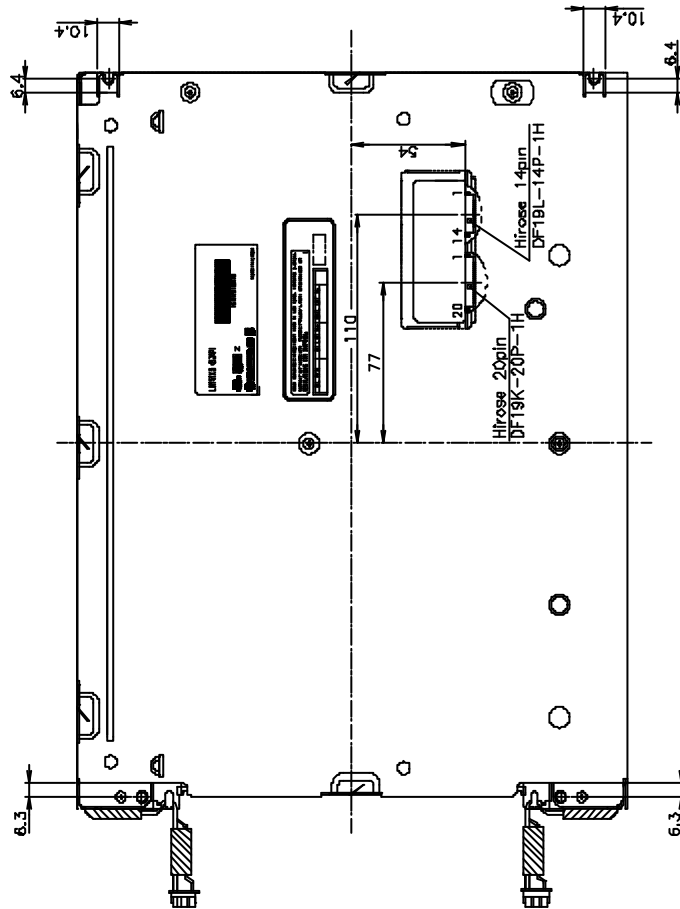

*. When a P3 Panel is applied, a "2" mark on the model name label is deleted.

Product General Specification

3.PRECAUTIONS

The LCD Products listed on this documents are not suitable for use of Military,Industry,Medical etc. system.

If customers intend to use these LCD products for above application, Please contact ours sales people in advance.