

1. SCOPE

1.1 Scope. This drawing forms a part of a one part - one part number documentation system (see 6.6 herein). Two product assurance classes consisting of military high reliability (device classes B, Q, and M) and space application (device classes S and V) and a choice of case outlines and lead finishes are available and are reflected in the complete Part or Identifying Number (PIN). Device class M microcircuits represent non-JAN class B microcircuits in accordance with 1.2.1 of MIL-STD-883, "Provisions for the use of MIL-STD-883 in conjunction with compliant non-JAN devices". When available, a choice of radiation hardness assurance (RHA) levels are reflected in the complete PIN.

1.2 PIN. The PIN shall be as shown in the following example:

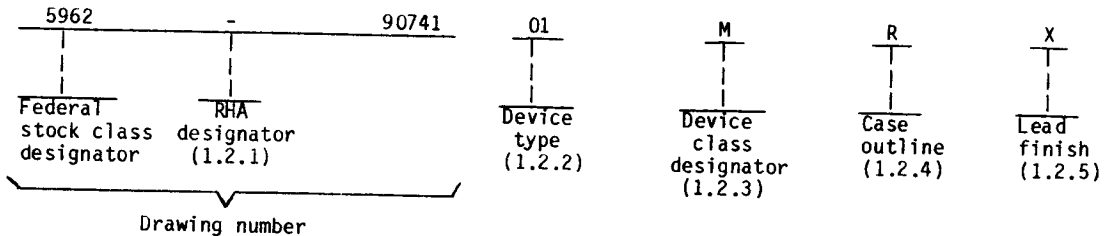

1.2.1 Radiation hardness assurance (RHA) designator. Device classes M, B, and S RHA marked devices shall meet the MIL-M-38510 specified RHA levels and shall be marked with the appropriate RHA designator. Device classes Q and V devices shall meet or exceed the electrical performance characteristics specified in table I herein after exposure to the specified irradiation levels specified in the absolute maximum ratings herein and the RHA marked device shall be marked in accordance with MIL-I-38535. A dash (-) indicates a non-RHA device.

1.2.2 Device type. The device type shall identify the circuit function as follows:

Device type	Generic number	Circuit function
01	54BCT2244	Octal buffers and line drivers/mos drivers with three-state outputs

1.2.3 Device class designator. The device class designator shall be a single letter identifying the product assurance level as follows:

Device class	Device requirements documentation
M	Vendor self-certification to the requirements for non-JAN class B microcircuits in accordance with 1.2.1 of MIL-STD-883
B or S	Certification and qualification to MIL-M-38510
Q or V	Certification and qualification to MIL-I-38535

STANDARDIZED MILITARY DRAWING DEFENSE ELECTRONICS SUPPLY CENTER DAYTON, OHIO 45444	SIZE A	5962-90741
	REVISION LEVEL	SHEET 2

1.2.4 Case outlines. For device classes M, B, and S, case outlines shall meet the requirements in appendix C of MIL-M-38510 and as listed below. For device classes Q and V, case outlines shall meet the requirements of MIL-I-38535, appendix C of MIL-M-38510, and as listed below:

Outline letter	Case outline
R	D-8 (20-lead, 1.060" x .310" x .200"), dual-in-line package
S	F-9 (20-lead, .540" x .300" x .100"), flat package
2	C-2 (20-terminal, .358" x .358" x .100"), square chip carrier package

1.2.5 Lead finish. The lead finish shall be as specified in MIL-M-38510 for classes M, B, and S or MIL-I-38535 for classes Q and V. Finish letter "X" shall not be marked on the microcircuit or its packaging. The "X" designation is for use in specifications when lead finishes A, B, and C are considered acceptable and interchangeable without preference.

1.3 Absolute maximum ratings. 1/

Supply voltage range (V_{CC})	- - - - -	-0.5 V dc to +7.0 V dc
Input voltage range	- - - - -	-0.5 V dc to +7.0 V dc
Voltage applied to any output in the disabled state	- - - - -	-0.5 V dc to 5.5 V dc
Voltage applied to any output in the high state	- - - - -	-0.5 V dc to V_{CC}
Input clamp current	- - - - -	-30 mA
Current into any output in the low state	- - - - -	96 mA
Storage temperature range	- - - - -	-65°C to +150°C
Lead temperature (soldering 10 seconds)	- - - - -	+300°C
Thermal resistance, junction-to-case (θ_{JC})	- - - - -	See MIL-M-38510, appendix C
Junction temperature (T_J)	- - - - -	+175°C
Power dissipation (P_D)	- - - - -	500 mW <u>2/</u>

1.4 Recommended operating conditions.

Supply voltage range (V_{CC})	- - - - -	+4.5 V dc minimum to +5.5 V dc maximum
Minimum high level input voltage (V_{IH})	- - - - -	2.0 V dc
Maximum low level input voltage (V_{IL})	- - - - -	0.8 V dc
Case operating temperature range (T_C)	- - - - -	-55°C to +125°C

1.5 Logic testing for device classes Q and V.

Fault coverage measurement of manufacturing logic tests (MIL-STD-883, test method 5012)	- - - -	XX percent <u>3/</u>
---	---------	----------------------

1/ Stresses above the absolute maximum rating may cause permanent damage to the device. Extended operation at the maximum levels may degrade performance and affect reliability.

2/ The P_D number is based upon dc values.

3/ Values will be added when they become available.

STANDARDIZED MILITARY DRAWING DEFENSE ELECTRONICS SUPPLY CENTER DAYTON, OHIO 45444	SIZE A		5962-90741
		REVISION LEVEL	SHEET 3

DESC FORM 193A
SEP 87

* U.S. GOVERNMENT PRINTING OFFICE: 1990-750-527R

2. APPLICABLE DOCUMENTS

2.1 Government specifications, standards, bulletin, and handbook. Unless otherwise specified, the following specifications, standards, bulletin, and handbook of the issue listed in that issue of the Department of Defense Index of Specifications and Standards specified in the solicitation, form a part of this drawing to the extent specified herein.

SPECIFICATIONS

MILITARY

- MIL-M-38510 - Microcircuits, General Specification for.
- MIL-I-38535 - Integrated Circuits, Manufacturing, General Specification for.

STANDARDS

MILITARY

- MIL-STD-480 - Configuration Control-Engineering Changes, Deviations and Waivers.
- MIL-STD-883 - Test Methods and Procedures for Microelectronics.

BULLETIN

MILITARY

- MIL-BUL-103 - List of Standardized Military Drawings (SMD's).

HANDBOOK

MILITARY

- MIL-HDBK-780 - Standardized Military Drawings.

(Copies of the specifications, standards, bulletin, and handbook required by manufacturers in connection with specific acquisition functions should be obtained from the contracting activity or as directed by the contracting activity.)

2.2 Order of precedence. In the event of a conflict between the text of this drawing and the references cited herein, the text of this drawing shall take precedence.

3. REQUIREMENTS

3.1 Item requirements. The individual item requirements for device class M shall be in accordance with 1.2.1 of MIL-STD-883, "Provisions for the use of MIL-STD-883 in conjunction with compliant non-JAN devices" and as specified herein. The individual item requirements for device classes B and S shall be in accordance with MIL-M-38510 and as specified herein. For device classes B and S, a full electrical characterization table for each device type shall be included in this SMD. The individual item requirements for device classes Q and V shall be in accordance with MIL-I-38535 and as specified herein.

3.2 Design, construction, and physical dimensions. The design, construction, and physical dimensions shall be as specified in MIL-M-38510 for device classes M, B, and S and MIL-I-38535 for device classes Q and V and herein.

3.2.1 Case outlines. The case outlines shall be in accordance with 1.2.4 herein.

STANDARDIZED MILITARY DRAWING DEFENSE ELECTRONICS SUPPLY CENTER DAYTON, OHIO 45444	SIZE A		5962-90741
		REVISION LEVEL	SHEET 4

3.2.2 Terminal connections. The terminal connections shall be as specified on figure 1.

3.2.3 Truth table. The truth table shall be as specified on figure 2.

3.2.4 Logic diagram. The logic diagram shall be as specified on figure 3.

3.3 Electrical performance characteristics and postirradiation parameter limits. Unless otherwise specified herein, the electrical performance characteristics and postirradiation parameter limits are as specified in table I and shall apply over the full case operating temperature range.

3.4 Electrical test requirements. The electrical test requirements shall be the subgroups specified in table IIA. The electrical tests for each subgroup are defined in table I.

3.5 Marking. The part shall be marked with the PIN listed in 1.2 herein. Marking for device class M shall be in accordance with MIL-STD-883 (see 3.1 herein). In addition, the manufacturer's PIN may also be marked as listed in MIL-BUL-103. Marking for device classes B and S shall be in accordance with MIL-M-38510. Marking for device classes Q and V shall be in accordance with MIL-I-38535.

3.5.1 Certification/compliance mark. The compliance mark for device class M shall be a "C" as required in MIL-STD-883 (see 3.1 herein). The certification mark for device classes B and S shall be a "J" or "JAN" as required in MIL-M-38510. The certification mark for device classes Q and V shall be a "QML" as required in MIL-I-38535.

3.6 Certificate of compliance. For device class M, a certificate of compliance shall be required from a manufacturer in order to be listed as an approved source of supply in MIL-BUL-103 (see 6.7.3 herein). For device classes Q and V, a certificate of compliance shall be required from a QML-38535 listed manufacturer in order to supply to the requirements of this drawing (see 6.7.2 herein). The certificate of compliance submitted to DESC-ECS prior to listing as an approved source of supply for this drawing shall affirm that the manufacturer's product meets, for device class M the requirements of MIL-STD-883 (see 3.1 herein), or for device classes Q and V, the requirements of MIL-I-38535 and the requirements herein.

3.7 Certificate of conformance. A certificate of conformance as required for device class M in MIL-STD-883 (see 3.1 herein), device classes B and S in MIL-M-38510, or for device classes Q and V in MIL-I-38535 shall be provided with each lot of microcircuits delivered to this drawing.

3.8 Notification of change for device class M. For device class M, notification to DESC-ECS of change of product (see 6.2 herein) involving devices acquired to this drawing is required for any change as defined in MIL-STD-480.

3.9 Verification and review for device class M. For device class M, DESC, DESC's agent, and the acquiring activity retain the option to review the manufacturer's facility and applicable required documentation. Offshore documentation shall be made available onshore at the option of the reviewer.

3.10 Microcircuit group assignment for device classes M, B, and S. Device classes M, B, and S devices covered by this drawing shall be in microcircuit group number 126 (see MIL-M-38510, appendix E).

3.11 Serialization for device class S. All device class S devices shall be serialized in accordance with MIL-M-38510.

4. QUALITY ASSURANCE PROVISIONS

4.1 Sampling and inspection. For device class M, sampling and inspection procedures shall be in accordance with section 4 of MIL-M-38510 to the extent specified in MIL-STD-883 (see 3.1 herein). For device classes B and S, sampling and inspection procedures shall be in accordance with MIL-M-38510 and method 5005 of MIL-STD-883, except as modified herein. For device classes Q and V, sampling and inspection procedures shall be in accordance with MIL-I-38535.

STANDARDIZED MILITARY DRAWING DEFENSE ELECTRONICS SUPPLY CENTER DAYTON, OHIO 45444	SIZE A		5962-90741
		REVISION LEVEL	SHEET 5

DESC FORM 193A
SEP 87

* U.S. GOVERNMENT PRINTING OFFICE: 1990-750-527R

TABLE I. Electrical performance characteristics.

Test	Symbol	Conditions -55°C < T _C < +125°C unless otherwise specified		Group A subgroups	Limits		Unit
					Min	Max	
High level output voltage	V _{OH}	V _{CC} = 4.5 V V _{IL} = 0.8 V V _{IH} = 2.0 V	I _{OH} = -1.0 mA	1,2,3	2.4		V
			I _{OH} = -12.0 mA		2.0		
Low level output voltage	V _{OL}	V _{CC} = 4.5 V V _{IL} = 0.8 V V _{IH} = 2.0 V	I _{OL} = 1 mA	1,2,3		0.5	
			I _{OL} = 12.0 mA			0.8	
Input clamp voltage	V _{IC}	V _{CC} = 4.5 V, I _{IN} = -18 mA		1,2,3		-1.2	
Off-state output current high level voltage applied	I _{OZH}	V _{CC} = 5.5 V, V _O = 2.7 V		1,2,3		50	μA
Off-state output current low level voltage applied	I _{OZL}	V _{CC} = 5.5 V, V _O = 0.5 V		1,2,3		-50	
High level input current	I _{IH1}	V _{CC} = 5.5 V, V _{IN} = 5.5 V		1,2,3		0.1	mA
	I _{IH2}	V _{CC} = 5.5 V, V _{IN} = 2.7 V		1,2,3		20	μA
Low level input current	I _{IL}	V _{CC} = 5.5 V, V _{IN} = 0.5 V		1,2,3		-1.0	mA
Short-circuit output current <u>1/</u>	I _{OS}	V _{CC} = 5.5 V, V _O = 0.0 V		1,2,3	-100	-225	
Supply current, outputs high	I _{CCH}	V _{CC} = 5.5 V, outputs open		1,2,3		37	
Supply current, outputs low	I _{CCL}	V _{CC} = 5.5 V, outputs open		1,2,3		77	
Supply current, outputs disabled to high-impedance state	I _{CCZ}	V _{CC} = 5.5 V, outputs open		1,2,3		10.0	
Functional tests		See 4.4.1b <u>2/</u>		7,8			

See footnotes at end of table.

STANDARDIZED MILITARY DRAWING DEFENSE ELECTRONICS SUPPLY CENTER DAYTON, OHIO 45444	SIZE A		5962-90741
		REVISION LEVEL	SHEET 6

DESC FORM 193A
SEP 87

* U.S. GOVERNMENT PRINTING OFFICE 1990 750 52/R

TABLE I. Electrical performance characteristics - Continued.

Test	Symbol	Conditions -55°C < T _C < +125°C unless otherwise specified	Group A subgroups	Limits		Unit
				Min	Max	
Propagation delay time, from A to Y	t _{PLH}	V _{CC} = 5.0 V C _L = 50 pF R ₁ = 500Ω	9	0.5	4.4	ns
	t _{PHL}	R ₂ = 500Ω See figure 4		1.6	6.3	
	t _{PLH}	V _{CC} = 4.5 V and 5.5 V C _L = 50 pF R ₁ = 500Ω	10,11	0.5	5.2	
	t _{PHL}	R ₂ = 500Ω See figure 4		1.6	7.1	
Output enable time, from \bar{G} to Y	t _{PZH}	V _{CC} = 5.0 V C _L = 50 pF R ₁ = 500Ω	9	2.4	7.7	ns
	t _{PZL}	R ₂ = 500Ω See figure 4		3.9	9.4	
	t _{PZH}	V _{CC} = 4.5 V and 5.5 V C _L = 50 pF R ₁ = 500Ω	10,11	2.4	9.1	
	t _{PZL}	R ₂ = 500Ω See figure 4		3.9	10.8	
Output disable time, from \bar{G} to Y	t _{PHZ}	V _{CC} = 5.0 V C _L = 50 pF R ₁ = 500Ω	9	1.7	6.9	ns
	t _{PLZ}	R ₂ = 500Ω See figure 4		2.8	8.3	
	t _{PHZ}	V _{CC} = 4.5 V and 5.5 V C _L = 50 pF R ₁ = 500Ω	10,11	1.7	8.1	
	t _{PLZ}	R ₂ = 500Ω See figure 4		2.8	10.9	

- 1/ The output conditions have been chosen to produce a current that closely approximates one half the true short-circuit output current, I_{OS}. Not more than one output shall be shorted at one time and the duration of test shall not exceed one second.
- 2/ Functional tests shall be conducted at input test conditions of 0.4 V ≤ V_{IL} ≤ 0.8 V and 2.0 V ≤ V_{IH} ≤ 2.4 V, for V_{CC} = 4.5 V and repeated at V_{CC} = 5.5 V.

STANDARDIZED MILITARY DRAWING DEFENSE ELECTRONICS SUPPLY CENTER DAYTON, OHIO 45444	SIZE A		5962-90741
		REVISION LEVEL	SHEET 7

DESC FORM 193A
SEP 87

* U.S. GOVERNMENT PRINTING OFFICE 1990-750-527R

4.2 Screening. For device class M, screening shall be in accordance with method 5004 of MIL-STD-883, and shall be conducted on all devices prior to quality conformance inspection. For device classes B and S, screening shall be in accordance with method 5004 of MIL-STD-883, and shall be conducted on all devices prior to qualification and quality conformance inspection. For device classes Q and V, screening shall be in accordance with MIL-I-38535, and shall be conducted on all devices prior to qualification and technology conformance inspection. The following additional criteria shall apply:

a. Burn-in test, method 1015 of MIL-STD-883.

(1) Test condition A, B, C, or D. For device class M, the test circuit shall be submitted to DESC-ECS for review with the certificate of compliance. For device classes B and S, the test circuit shall be submitted to the qualifying activity. For device classes Q and V, the test circuit shall be submitted to DESC-ECS with the certificate of compliance and under the control of the device manufacturer's technical review board (TRB) in accordance with MIL-I-38535.

(2) $T_A = +125^\circ\text{C}$, minimum.

b. Interim and final electrical test parameters shall be as specified in table IIA herein. For device class M, interim electrical parameter tests prior to burn-in are optional at the discretion of the manufacturer.

4.2.1 Additional screening for device class V. Additional screening for device class V beyond the requirements of device class Q shall be as specified in appendix B of MIL-I-38535 and as detailed in table IIB herein. These additional screens may be used to satisfy space system requirements and shall be reflected in the PIN (see 6.7).

4.3 Qualification inspection.

4.3.1 Qualification inspection for device classes B and S. Qualification inspection for device classes B and S shall be in accordance with MIL-M-38510. Inspections to be performed shall be those specified in method 5005 of MIL-STD-883 and herein for groups A, B, C, D, and E inspections (see 4.4.1 through 4.4.5).

4.3.2 Qualification inspection for device classes Q and V. Qualification inspection for device classes Q and V shall be in accordance with MIL-I-38535. Inspections to be performed shall be those specified in MIL-I-38535 and herein for groups A, B, C, D, and E inspections (see 4.4.1 through 4.4.5).

4.4 Conformance inspection. Quality conformance inspection for device class M shall be in accordance with MIL-STD-883 (see 3.1 herein) and as specified herein. Quality conformance inspection for device classes B and S shall be in accordance with MIL-M-38510 and as specified herein. Inspections to be performed for device classes M, B, and S shall be those specified in method 5005 of MIL-STD-883 and herein for groups A, B, C, D, and E inspections (see 4.4.1 through 4.4.5). Technology conformance inspection for classes Q and V shall be in accordance with MIL-I-38535 including groups A, B, C, D, and E inspections and as specified herein.

STANDARDIZED MILITARY DRAWING DEFENSE ELECTRONICS SUPPLY CENTER DAYTON, OHIO 45444	SIZE A		5962-90741
		REVISION LEVEL	SHEET 8

DESC FORM 193A
SEP 87

* U.S. GOVERNMENT PRINTING OFFICE 1990 750-527R

Device type	01
Case outlines	R, S, and 2
Terminal number	Terminal symbol
1	$\overline{1G}$
2	1A1
3	2Y4
4	1A2
5	2Y3
6	1A3
7	2Y2
8	1A4
9	2Y1
10	GND
11	2A1
12	1Y4
13	2A2
14	1Y3
15	2A3
16	1Y2
17	2A4
18	1Y1
19	$\overline{2G}$
20	VCC

FIGURE 1. Terminal connections.

Inputs		Output
\overline{G}	A	Y
H	X	Z
L	L	L
L	H	H

H = High logic level
L = Low logic level
Z = High-impedance state
X = Irrelevant

FIGURE 2. Truth table.

STANDARDIZED MILITARY DRAWING DEFENSE ELECTRONICS SUPPLY CENTER DAYTON, OHIO 45444	SIZE A		5962-90741
		REVISION LEVEL	SHEET 9

DESC FORM 193A
SEP 87

* U.S. GOVERNMENT PRINTING OFFICE: 1990-750-527R

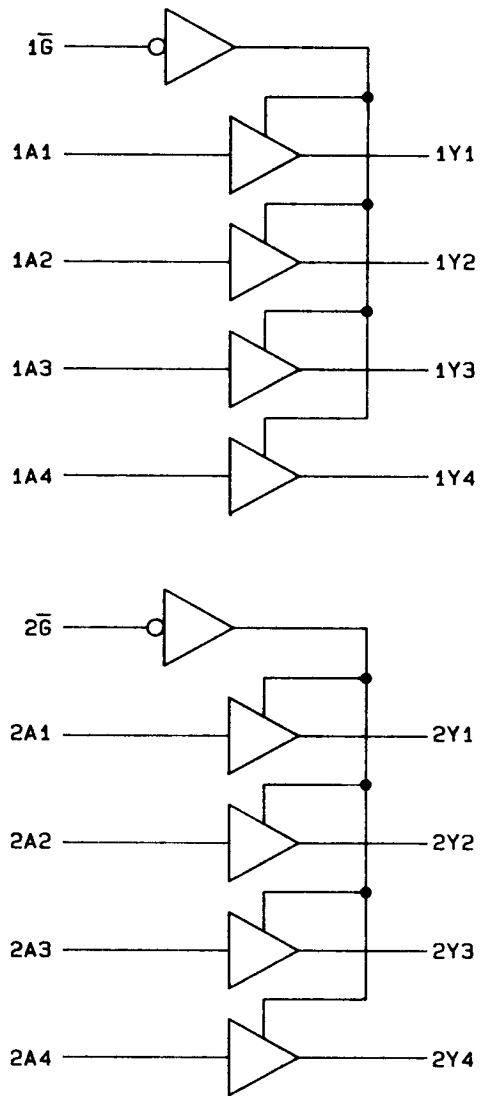
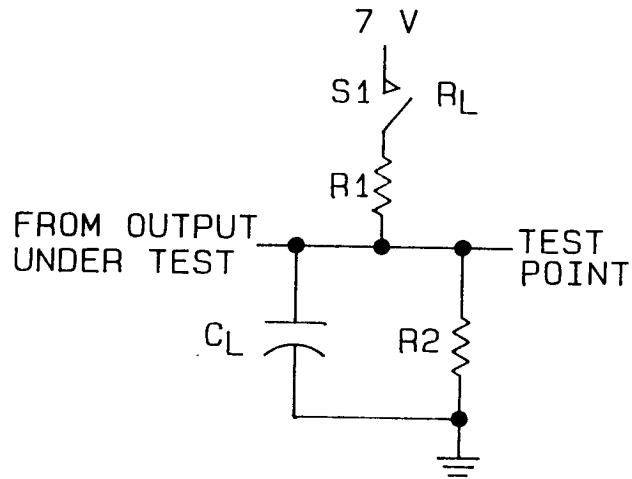

FIGURE 3. Logic diagram.

STANDARDIZED MILITARY DRAWING DEFENSE ELECTRONICS SUPPLY CENTER DAYTON, OHIO 45444	SIZE A		5962-90741
		REVISION LEVEL	SHEET 10

DESC FORM 193A
SEP 87

U.S. GOVERNMENT PRINTING OFFICE: 1984 O-217-31



$C_L = 50 \text{ pF}$, includes probe and jig capacitance.
 $R_L = R_1 = R_2 = 500\Omega$.

Switch position table

Test	S1
t_{PLH}	Open
t_{PHL}	Open
t_{pZH}	Open
t_{pZL}	Closed
t_{pHZ}	Open
t_{pLZ}	Closed

FIGURE 4. Switching waveforms and test circuit.

STANDARDIZED MILITARY DRAWING DEFENSE ELECTRONICS SUPPLY CENTER DAYTON, OHIO 45444	SIZE A		5962-90741
		REVISION LEVEL	SHEET 11

DESC FORM 193A
 SEP 87

* U.S. GOVERNMENT PRINTING OFFICE: 1990-750-527R

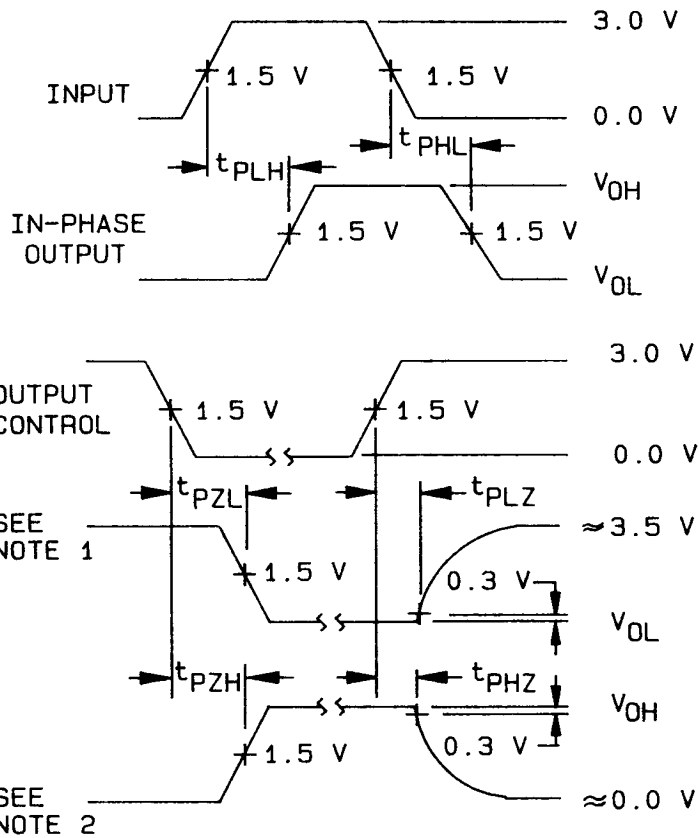

NOTES:

1. Output with internal conditions such that the output is low except when disabled by the output control.
2. Output with internal conditions such that the output is high except when disabled by the output control.
3. All input pulses are supplied by the generators having the following characteristics:
 $PRR < 10 \text{ MHz}$, $Z_0 = 50\Omega$, $t_r = 2.5 \text{ ns}$, $t_f = 2.5 \text{ ns}$.
4. The outputs are measured one at a time with one transition per measurement.

FIGURE 4. Switching waveforms and test circuit - Continued.

STANDARDIZED MILITARY DRAWING DEFENSE ELECTRONICS SUPPLY CENTER DAYTON, OHIO 45444	SIZE A	5962-90741
		REVISION LEVEL

DESC FORM 193A
SEP 87

* U.S. GOVERNMENT PRINTING OFFICE 1990 750-527R

4.4.1 Group A inspection.

- a. Tests shall be as specified in table IIA herein.
- b. For device class M, subgroups 7 and 8 tests shall be sufficient to verify the truth table. For device classes B and S, subgroups 7 and 8 tests shall be sufficient to verify the truth table as approved by the qualifying activity. For device classes Q and V, subgroups 7 and 8 shall include verifying the functionality of the device, these tests shall have been fault graded in accordance with MIL-STD-883, test method 5012 (see 1.5 herein).
- c. Subgroups 4, 5, and 6 in table I, method 5005 of MIL-STD-883 shall be omitted.

4.4.2 Group B inspection. The group B inspection end-point electrical parameters shall be as specified in table IIA herein.

4.4.3 Group C inspection.

- a. End-point electrical parameters shall be as specified in table IIA herein.
- b. Steady-state life test conditions, method 1005 of MIL-STD-883:
 - (1) Test condition A, B, C, or D. For device class M, the test circuit shall be submitted to DESC-ECS for review with the certificate of compliance. For device classes B and S, the test circuit shall be submitted to the qualifying activity. For device classes Q and V, the test circuit shall be submitted to DESC-ECS with the certificate of compliance and under the control of the device manufacturer's TRB in accordance with MIL-I-38535.
 - (2) $T_A = +125^{\circ}\text{C}$, minimum.
 - (3) Test duration: 1,000 hours, except as permitted by method 1005 of MIL-STD-883.

4.4.4 Group D inspection. For group D inspection, end-point electrical parameters shall be as specified in table IIA herein.

4.4.5 Group E inspection. Group E inspection is required only for parts intended to be marked as radiation hardness assured (see 3.5 herein). RHA levels for device classes B and S shall be M, D, R, and H and for device class M shall be M and D. RHA quality conformance inspection sample tests shall be performed at the level specified in the acquisition document. RHA tests for device classes Q and V shall be performed in accordance with MIL-I-38535 and 1.2.1 herein.

- a. RHA tests for device classes B and S for levels M, D, R, and H or for device class M for levels M and D shall be performed through each level to determine at what levels the devices meet the RHA requirements. These RHA tests shall be performed for initial qualification and after design or process changes which may affect the RHA performance of the device.
- b. End-point electrical parameters shall be as specified in table IIA herein.
- c. Prior to total dose irradiation, each selected sample shall be assembled in its qualified package. It shall pass the specified group A electrical parameters in table I for subgroups specified in table IIA herein.
- d. For device classes M, B, and S, the devices shall be subjected to radiation hardness assured tests as specified in MIL-M-38510 for RHA level being tested, and meet the post irradiation end-point electrical parameter limits as defined in table I at $T_A = 25^{\circ}\text{C} \pm 5$ percent, after exposure.

STANDARDIZED MILITARY DRAWING DEFENSE ELECTRONICS SUPPLY CENTER DAYTON, OHIO 45444	SIZE A		5962-90741
		REVISION LEVEL	SHEET 13

DESC FORM 193A
SEP 87

* U.S. GOVERNMENT PRINTING OFFICE: 1980-750-527R

TABLE IIA. Electrical test requirements. 1/ 2/

Test requirements	Subgroups (per method 5005, table 1)			Subgroups (per MIL-I-38535, table III)	
	Device class M	Device class B	Device class S	Device class Q	Device class V
Interim electrical parameters (see 4.2)		1	1	1	1
Final electrical parameters (see 4.2)	1*,2,3,7, 8,9,10,11	1*,2,3,7, 8,9,10,11	1*,2,3,7, 8,9,10,11	1*,2,3,7, 8,9,10,11	1*,2,3,7, 8,9,10,11
Group A test requirements (see 4.4)	1,2,3,7, 8,9,10,11	1,2,3,7, 8,9,10,11	1,2,3,7, 8,9,10,11	1,2,3,7, 8,9,10,11	1,2,3,7, 8,9,10,11
Group B end-point electrical parameters (see 4.4)			1,2,3, 9,10,11		1,2,3, 9,10,11
Group C end-point electrical parameters (see 4.4)	1,2,3	1,2,3		1,2,3	
Group D end-point electrical parameters (see 4.4)	1,2,3	1,2,3	1,2,3	1,2,3	1,2,3
Group E end-point electrical parameters (see 4.4)	1,7,9	1,7,9	1,7,9	1,7,9	1,7,9

1/ Blank spaces indicate tests are not applicable.

2/ * indicates PDA applies to subgroup 1.

- e. Prior to and during total dose irradiation testing, the devices shall be biased to establish a worst case condition as specified in the radiation exposure circuit.
- (1) Inputs tested high, $V_{CC} = \Omega +5\%$, $R_{CC} = \Omega +5\%$, $V_{IN} = \Omega +20\%$, and all outputs are open. (Values will be added when they become available.)
 - (2) Inputs tested low $V_{CC} = \Omega +5\%$, $R_{CC} = \Omega +5\%$, $V_{IN} = 0.0 \text{ V dc}$, and all outputs are open. (Values will be added when they become available.)
- f. For device classes M, B, and S, subgroups 1 and 2 in table V, method 5005 of MIL-STD-883 shall be tested as appropriate for device construction.
- g. When specified in the purchase order or contract, a copy of the RHA delta limits shall be supplied.

STANDARDIZED MILITARY DRAWING DEFENSE ELECTRONICS SUPPLY CENTER DAYTON, OHIO 45444	SIZE A		5962-90741
		REVISION LEVEL	SHEET 14

DESC FORM 193A
SEP 87

* U.S. GOVERNMENT PRINTING OFFICE 1990-750-527R

TABLE IIB. Additional screening for device class V.

Test	MIL-STD-883, test method	Lot requirement
Particle impact noise detection	2020	100%
Internal visual	2010, condition A or approved alternate	100%
Nondestructive bond pull	2023 or approved alternate	100%
Reverse bias burn-in	1015	100%
Burn-in	1015, total of 240 hrs. at +125°C	100%
Radiographic	2012	100%

5. PACKAGING

5.1 Packaging requirements. The requirements for packaging shall be in accordance with MIL-M-38510 for device classes M, B, and S and MIL-I-38535 for device classes Q and V.

6. NOTES

6.1 Intended use. Microcircuits conforming to this drawing are intended for use for Government microcircuit applications (original equipment), design applications, and logistics purposes.

6.1.1 Replaceability. Microcircuits covered by this drawing will replace the same generic device covered by a contractor-prepared specification or drawing.

6.1.2 Substitutability. Device classes B and Q devices will replace device class M devices.

6.2 Configuration control of SMD's. All proposed changes to existing SMD's will be coordinated with the users of record for the individual documents. This coordination will be accomplished in accordance with MIL-STD-481 using DD Form 1693, Engineering Change Proposal (Short Form).

6.3 Record of users. Military and industrial users shall inform Defense Electronics Supply Center when a system application requires configuration control and which SMD's are applicable to that system. DESC will maintain a record of users and this list will be used for coordination and distribution of changes to the drawings. Users of drawings covering microelectronic devices (FSC 5962) should contact DESC-ECS, telephone (513) 296-6022.

6.4 Comments. Comments on this drawing should be directed to DESC-ECS, Dayton, Ohio 45444, or telephone (513) 296-5375.

STANDARDIZED MILITARY DRAWING DEFENSE ELECTRONICS SUPPLY CENTER DAYTON, OHIO 45444	SIZE A		5962-90741
		REVISION LEVEL	SHEET 15

DESC FORM 193A
SEP 87

* U.S. GOVERNMENT PRINTING OFFICE: 1990-750-527R

6.5 Symbols, definitions, and functional descriptions.

GND	- - - - -	Ground zero voltage potential.
I _{CC}	- - - - -	Quiescent supply current.
I _{IL}	- - - - -	Input current low.
I _{IH}	- - - - -	Input current high.
T _C	- - - - -	Case temperature.
T _A	- - - - -	Ambient temperature.
V _{CC}	- - - - -	Positive supply voltage.
V _{IC}	- - - - -	Input clamp voltage.

b.6 One part - one part number system. The one part - one part number system described below has been developed to allow for transitions between identical generic devices covered by the four major microcircuit requirements documents (MIL-M-38510, MIL-H-38534, MIL-I-38535, and 1.2.1 of MIL-STD-883) without the necessity for the generation of unique PIN's. The four military requirements documents represent different class levels, and previously when a device manufacturer upgraded military product from one class level to another, the benefits of the upgraded product were unavailable to the Original Equipment Manufacturer (OEM), that was contractually locked into the original unique PIN. By establishing a one part number system covering all four documents, the OEM can acquire to the highest class level available for a given generic device to meet system needs without modifying the original contract parts selection criteria.

<u>Military documentation format</u>	<u>Example PIN under new system</u>	<u>Manufacturing source listing</u>	<u>Document listing</u>
New MIL-M-38510 Military Detail Specifications (in the SMD format)	5962-XXXXXZZ(B or S)YY	QPL-38510 (Part 1 or 2)	MIL-BUL-103
New MIL-H-38534 Standardized Military Drawings	5962-XXXXXZZ(H or K)YY	QML-38534	MIL-BUL-103
New MIL-I-38535 Standardized Military Drawings	5962-XXXXXZZ(Q or V)YY	QML-38535	MIL-BUL-103
New 1.2.1 of MIL-STD-883 Standardized Military Drawings	5962-XXXXXZZ(M)YY	MIL-BUL-103	MIL-BUL-103

6.7 Sources of supply.

6.7.1 Sources of supply for device classes B and S. Sources of supply for device classes B and S are listed in QPL-38510.

6.7.2 Sources of supply for device classes Q and V. Sources of supply for device classes Q and V are listed in QML-38535. The vendors listed in QML-38535 have submitted a certificate of compliance (see 3.6 herein) to DESC-ECS and have agreed to this drawing.

6.7.3 Approved sources of supply for device class M. Approved sources of supply for class M are listed in MIL-BUL-103. The vendors listed in MIL-BUL-103 have agreed to this drawing and a certificate of compliance (see 3.6 herein) has been submitted to and accepted by DESC-ECS.

STANDARDIZED MILITARY DRAWING DEFENSE ELECTRONICS SUPPLY CENTER DAYTON, OHIO 45444	SIZE A	5962-90741
	REVISION LEVEL	SHEET 16

DESC FORM 193A
SEP 87

* U.S. GOVERNMENT PRINTING OFFICE: 1990-750-527R

021723