

1. SCOPE

1.1 Scope. This drawing describes device requirements for class B microcircuits in accordance with 1.2.1 of MIL-STD-883, "Provisions for the use of MIL-STD-883 in conjunction with compliant non-JAN devices".

1.2 Part number. The complete part number shall be as shown in the following example:

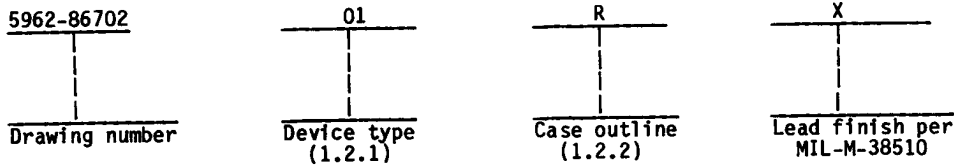

1.2.1 Device type. The device type shall identify the circuit function as follows:

<u>Device type</u>	<u>Generic number</u>	<u>Circuit function</u>
01	25LS2519 or 2919	Quad register with two independently controlled three-state outputs

1.2.2 Case outlines. The case outlines shall be as designated in appendix C of MIL-M-38510, and as follows:

<u>Outline letter</u>	<u>Case outline</u>
R	D-8 (20-lead, 1/4" x 1 1/16"), dual-in-line package
S	F-9 (20-lead, 1/4" x 1/2"), flat package
2	C-2 (20-terminal, .350" x .350"), square chip carrier package

1.3 Absolute maximum ratings.

Supply voltage range - - - - -	-0.5 V dc to +7.0 V dc
Input voltage range- - - - -	-1.5 V dc to 7.0 V dc
Storage temperature range- - - - -	-65°C to +150°C
Maximum power dissipation (P _D) 1/ - - - - -	700 mW
Lead temperature (soldering, 10 seconds) - - - - -	300°C
Thermal resistance, junction-to-case (θ _{JC}):	
Case R - - - - -	23°C/W
Case S - - - - -	21°C/W
Case 2 - - - - -	25°C/W
Junction temperature (T _J)- - - - -	150°C
DC output current into outputs - - - - -	30 mA
DC input current - - - - -	-30 mA to +5.0 mA

1/ Must withstand the added P_D due to short circuit test (e.g., I_{OS}).

MILITARY DRAWING DEFENSE ELECTRONICS SUPPLY CENTER DAYTON, OHIO	SIZE A	CODE IDENT. NO. 14933	DWG NO. 5962-86702
		REV	PAGE 2

1.4 Recommended operating conditions.

Supply voltage (V_{CC}) - - - - -	+4.5 V dc to +5.5 V dc
Minimum high-level input voltage (V_{IH}) - - - - -	2.0 V dc
Maximum low-level input voltage (V_{IL}) - - - - -	0.7 V dc
Ambient operating temperature range (T_A) - - - - -	-55°C to +125°C
Setup time, data enable - - - - -	25 ns min
Hold time, data enable - - - - -	0 ns min
Setup time, clear recovery (inactive), to clock - - - - -	24 ns min
Clear pulse width - - - - -	20 ns min
Clock pulse width high - - - - -	20 ns min
Clock pulse width low - - - - -	20 ns min
Setup time, data - - - - -	15 ns min
Hold time, data - - - - -	10 ns min

2. APPLICABLE DOCUMENTS

2.1 Government specification and standard. Unless otherwise specified, the following specification and standard, of the issue listed in that issue of the Department of Defense Index of Specifications and Standards specified in the solicitation, form a part of this drawing to the extent specified herein.

SPECIFICATION

MILITARY

MIL-M-38510 - Microcircuits, General Specification for.

STANDARD

MILITARY

MIL-STD-883 - Test Methods and Procedures for Microelectronics.

(Copies of the specification and standard required by manufacturers in connection with specific acquisition functions should be obtained from the contracting activity or as directed by the contracting activity.)

2.2 Order of precedence. In the event of a conflict between the text of this drawing and the references cited herein, the text of this drawing shall take precedence.

3. REQUIREMENTS

3.1 Item requirements. The individual item requirements shall be in accordance with 1.2.1 of MIL-STD-883, "Provisions for the use of MIL-STD-883 in conjunction with compliant non-JAN devices" and as specified herein.

3.2 Design, construction, and physical dimensions. The design, construction, and physical dimensions shall be as specified in MIL-M-38510 and herein.

3.2.1 Terminal connections. The terminal connections shall be as specified on figure 1.

3.2.2 Truth table. The truth table shall be as specified on figure 2.

3.2.3 Logic diagram. The logic diagram shall be as specified on figure 3.

3.2.4 Case outlines. The case outlines shall be in accordance with 1.2.2 herein.

MILITARY DRAWING DEFENSE ELECTRONICS SUPPLY CENTER DAYTON, OHIO	SIZE A	CODE IDENT. NO. 14933	DWG NO. 5962-86702
		REV	PAGE 3

DESC FORM 193A
FEB 86

CASES R AND S

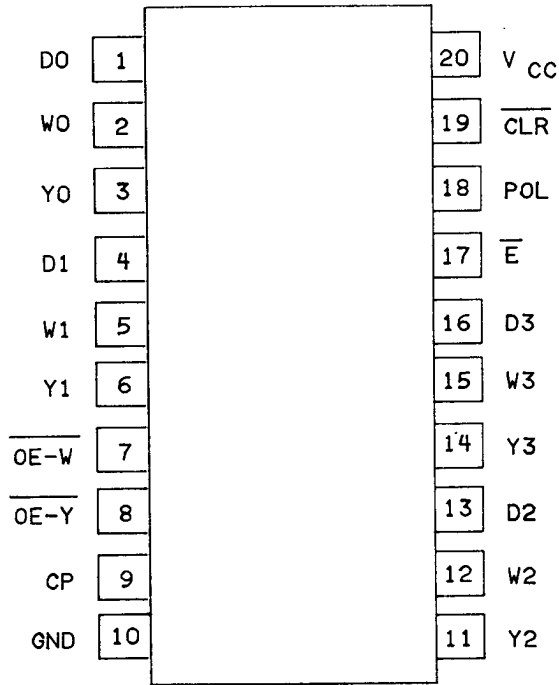

CASE 2

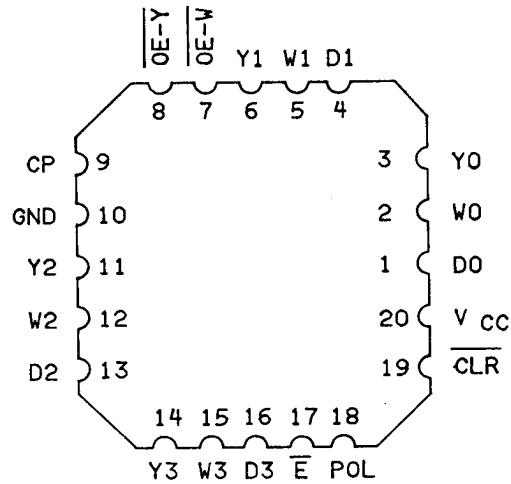

FIGURE 1. Terminal connections.

MILITARY DRAWING DEFENSE ELECTRONICS SUPPLY CENTER DAYTON, OHIO	SIZE A	CODE IDENT. NO. 14933	DWG NO. 5962-86702
		REV	PAGE 4

DESC FORM 193A
FEB 86

Function	Inputs							Internal	Outputs	
	CP	D ₁	E	CLR	POL	OE-W	OE-Y	Q	W ₁	Y ₁
Output Three-State-Control	X	X	X	X	X	H	L	NC	Z	Enabled
	X	X	X	X	X	L	H	NC	Enabled	Z
	X	X	X	X	X	H	H	NC	Z	Z
	X	X	X	X	X	L	L	NC	Enabled	Enabled
W ₁ Polarity	X	X	X	X	L	L	L	NC	Non-Inverting Inverting	Non-Inverting Non-Inverting
	X	X	X	X	H	L	L	NC		
Asynchronous Clear	X	X	X	L	L	L	L	L	L	L
	X	X	X	L	H	L	L	L	H	L
Clock Enabled	↑	X	H	H	X	X	X	NC	NC L H H L	NC L L H H
	↑	L	L	H	L	L	L	L		
	↑	L	L	H	H	L	L	L		
	↑	H	L	H	L	L	L	H		
	↑	H	L	H	H	L	L	H		

L = Low
 H = High
 Z = High impedance
 X = Don't care
 NC = No change
 ↑ = Low to high transition

FIGURE 2. Truth table.

MILITARY DRAWING DEFENSE ELECTRONICS SUPPLY CENTER DAYTON, OHIO	SIZE A	CODE IDENT. NO. 14933	DWG NO. 5962-86702
		REV	PAGE 5

DESC FORM 193A
FEB 86

3.3 Electrical performance characteristics. Unless otherwise specified, the electrical performance characteristics are as specified in table I and apply over the full recommended ambient operating temperature range.

3.4 Marking. Marking shall be in accordance with MIL-STD-883 (see 3.1 herein). The part shall be marked with the part number listed in 1.2 herein. In addition, the manufacturer's part number may also be marked as listed in 6.4 herein.

3.5 Certificate of compliance. A certificate of compliance shall be required from a manufacturer in order to be listed as an approved source of supply in 6.4. The certificate of compliance submitted to DESC-ECS prior to listing as an approved source of supply shall state that the manufacturer's product meets the requirements of MIL-STD-883 (see 3.1 herein) and the requirements herein.

3.6 Certificate of conformance. A certificate of conformance as required in MIL-STD-883 (see 3.1 herein) shall be provided with each lot of microcircuits delivered to this drawing.

3.7 Notification of change. Notification of change to DESC-ECS shall be required in accordance with MIL-STD-883 (see 3.1 herein).

3.8 Verification and review. DESC, DESC's agent, and the acquiring activity retain the option to review the manufacturer's facility and applicable required documentation. Offshore documentation shall be made available onshore at the option of the reviewer.

4. QUALITY ASSURANCE PROVISIONS

4.1 Sampling and inspection. Sampling and inspection procedures shall be in accordance with section 4 of MIL-M-38510 to the extent specified in MIL-STD-883 (see 3.1 herein).

4.2 Screening. Screening shall be in accordance with method 5004 of MIL-STD-883, and shall be conducted on all devices prior to quality conformance inspection. The following additional criteria shall apply:

a. Burn-in test (method 1015 of MIL-STD-883).

(1) Test condition A, B, C, or D using the circuit submitted with the certificate of compliance (see 3.5 herein).

(2) $T_A = +125^{\circ}\text{C}$, minimum.

b. Interim and final electrical test parameters shall be as specified in table II herein, except interim electrical parameter tests prior to burn-in are optional at the discretion of the manufacturer.

4.3 Quality conformance inspection. Quality conformance inspection shall be in accordance with method 5005 of MIL-STD-883 including groups A, B, C, and D inspections. The following additional criteria shall apply.

4.3.1 Group A inspection.

a. Tests shall be as specified in table II herein.

b. Subgroups 4, 5, and 6 in table I, method 5005 of MIL-STD-883 shall be omitted.

c. Subgroup 7 and 8 tests shall verify the truth table.

MILITARY DRAWING DEFENSE ELECTRONICS SUPPLY CENTER DAYTON, OHIO	SIZE A	CODE IDENT. NO. 14933	DWG NO. 5962-86702
		REV	PAGE 7

DESC FORM 193A
FEB 86

TABLE I. Electrical performance characteristics.

Test	Symbol	Conditions $-55^{\circ}\text{C} \leq T_A \leq +125^{\circ}\text{C}$	Group A subgroups	Limits		Unit	
				Min	Max		
High level output voltage	V_{OH}	$V_{CC} = 4.5\text{ V}$, $I_{OH} = -1.0\text{ mA}$, $V_{IN} = 0.7\text{ V}$ or 2.0 V	1, 2, 3	2.4		V	
Low level output voltage	V_{OL}	$V_{CC} = 4.5\text{ V}$, $V_{IN} = 0.7\text{ V}$ or 2.0 V	$I_{OL} = 4.0\text{ mA}$	1, 2, 3		0.4	V
			$I_{OL} = 8.0\text{ mA}$	1, 2, 3		0.45	V
			$I_{OL} = 12.0\text{ mA}$	1, 2, 3		0.5	V
Input clamp voltage	V_{IC}	$V_{CC} = 4.5\text{ V}$, $I_{IN} = -18\text{ mA}$	1, 2, 3		-1.5	V	
High level input current	I_{IH1}	$V_{CC} = 5.5\text{ V}$, $V_{IN} = 2.7\text{ V}$	1, 2, 3		20	μA	
	I_{IH2}	$V_{CC} = 5.5\text{ V}$, $V_{IN} = 7.0\text{ V}$	1, 2, 3		100	μA	
Low level input current	I_{IL}	$V_{CC} = 5.5\text{ V}$, $V_{IN} = 0.4\text{ V}$	1, 2, 3		-0.36	mA	
Short circuit output current	I_{OS}	$V_{CC} = 5.5\text{ V}$, $V_{OUT} = 0.0\text{ V}$ $\frac{1}{1}$	1, 2, 3	-15	-85	mA	
Supply current	I_{CC}	Inputs grounded, $V_{CC} = 5.5\text{ V}$, Outputs open	1, 2, 3		36	mA	
Off-state output current	I_{OZH}	$V_{CC} = 5.5\text{ V}$, $V_{OUT} = 2.4\text{ V}$	1, 2, 3		20	μA	
	I_{OZL}	$V_{CC} = 5.5\text{ V}$, $V_{OUT} = 0.4\text{ V}$	1, 2, 3		-20	μA	

See footnote at end of table.

MILITARY DRAWING DEFENSE ELECTRONICS SUPPLY CENTER DAYTON, OHIO	SIZE A	CODE IDENT. NO. 14933	DWG NO. 5962-86702
		REV	PAGE 8

DESC FORM 193A
FEB 86

TABLE I. Electrical performance characteristics - Continued.

Test	Symbol	Conditions $-55^{\circ}\text{C} \leq T_A \leq +125^{\circ}\text{C}$	Group A subgroups	Limits		Unit
				Min	Max	
Propagation delay from CP to Y1	t _{PLH1}	V _{CC} = 4.5 V to 5.5 V, C _L = 50 pF	9, 10, 11		42	ns
	t _{PHL1}				45	ns
Propagation delay from CP to W1	t _{PLH2}		9, 10, 11		43	ns
	t _{PHL2}				48	ns
Propagation delay from clear to Y1	t _{PHL3}		9, 10, 11		58	ns
Propagation delay from clear to W1	t _{PLH4}		9, 10, 11		43	ns
	t _{PHL4}				53	ns
Propagation delay from polarity to W1	t _{PLH5}		9, 10, 11		45	ns
	t _{PHL5}				44	ns
Propagation delay from OE to W1 or Y1	t _{PZH}		9, 10, 11		27	ns
	t _{PZL}			35	ns	
Propagation delay from OE to W1 or Y1	t _{PHZ}	V _{CC} = +4.5 V to +5.5 V, C _L = 5.0 pF	9, 10, 11		45	ns
	t _{PLZ}				26	ns

1/ Not more than one output should be shorted at a time, and the duration of the short circuit condition should not exceed one second.

MILITARY DRAWING DEFENSE ELECTRONICS SUPPLY CENTER DAYTON, OHIO	SIZE A	CODE IDENT. NO. 14933	DWG NO. 5962-86702
		REV	PAGE 9

DESC FORM 193A
FEB 86

4.3.2 Groups C and D inspections.

- a. End-point electrical parameters shall be as specified in table II herein.
- b. Steady-state life test (method 1005 of MIL-STD-883) conditions:
 - (1) Test condition A, B, C, or D using the circuit submitted with the certificate of compliance (see 3.5 herein).
 - (2) $T_A = +125^\circ\text{C}$, minimum.
 - (3) Test duration: 1,000 hours, except as permitted by appendix B of MIL-M-38510 and method 1005 of MIL-STD-883.

TABLE II. Electrical test requirements.

MIL-STD-883 test requirements	Subgroups (per method 5005, table I)
Interim electrical parameters (method 5004)	---
Final electrical test parameters (method 5004)	1*, 2, 3, 7, 8, 9
Group A test requirements (method 5005)	1, 2, 3, 7, 8, 9, 10**, 11**
Groups C and D end-point electrical parameters (method 5005)	1, 2, 3

*PDA applies to subgroup 1.
 **Subgroups 10 and 11, if not tested, shall be guaranteed to the specified limits in table I.

5. PACKAGING

5.1 Packaging requirements. The requirements for packaging shall be in accordance with MIL-M-38510.

6. NOTES

6.1 Intended use. Microcircuits conforming to this drawing are intended for use when military specifications do not exist and qualified military devices that will perform the required function are not available for OEM application. When a military specification exists and the product covered by this drawing has been qualified for listing on QPL-38510, the device specified herein will be inactivated and will not be used for new design. The QPL-38510 product shall be the preferred item for all applications.

6.2 Replaceability. Microcircuits covered by this drawing will replace the same generic device covered by a contractor-prepared specification or drawing.

MILITARY DRAWING DEFENSE ELECTRONICS SUPPLY CENTER DAYTON, OHIO	SIZE A	CODE IDENT. NO. 14933	DWG NO. 5962-86702
		REV	PAGE 10

DESC FORM 193A
FEB 86

6.3 Comments. Comments on this drawing should be directed to DESC-ECS, Dayton, Ohio 45444, or telephone 513-296-5375.

6.4 Approved source of supply. An approved source of supply is listed herein. Additional sources will be added as they become available. The vendor listed herein has agreed to this drawing and a certificate of compliance (see 3.5 herein) has been submitted to DESC-ECS.

Military drawing part number	Vendor CAGE number	Vendor similar part number <u>1/</u>
5962-8670201RX	34335	AM25LS2519/BRA AM2919/BRA
5962-8670201SX	34335	AM25LS2519/BSA AM2919/BSA
5962-86702012X	34335	AM25LS2519/B2C AM2919/B2C

1/ Caution. Do not use this number for item acquisition. Items acquired to this number may not satisfy the performance requirements of this drawing.

Vendor CAGE number

34335

Vendor name and address

Advanced Micro Devices, Incorporated
901 Thompson Place
P.O.Box 3453
Sunnyvale, CA 94088

MILITARY DRAWING DEFENSE ELECTRONICS SUPPLY CENTER DAYTON, OHIO	SIZE A	CODE IDENT. NO. 14933	DWG NO. 5962-86702
		REV	PAGE 11

DESC FORM 193A
FEB 86