




## Helping Customers Innovate, Improve & Grow



### Description

Vectron's VM-822 Crystal Oscillator is a silicon based MEMS stabilized, differential output oscillator, operating off a 2.5 or 3.3 volt supply in a hermetically sealed 3.2x2.5 plastic package.

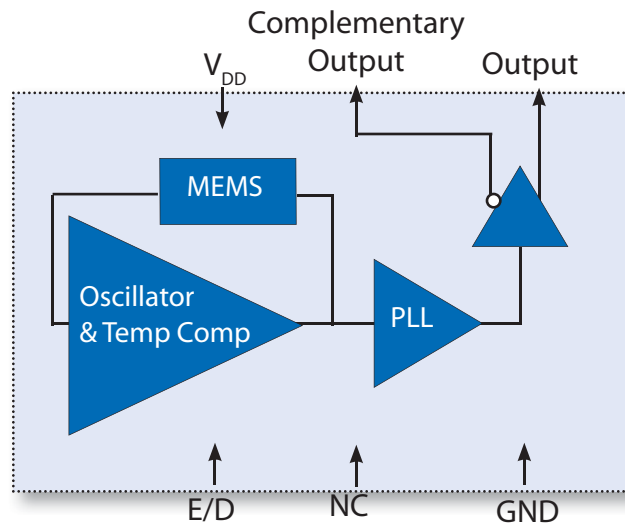
### Features

- High Shock MEMS based Oscillator
- 10.00-460.0000MHz Output Frequencies
- Low Power
- Differential Output
- Enable/Disable
- 2.25V to 3.6V Operation
- -20/70°C or -40/85°C Operation
- Product is compliant to RoHS directive  and fully compatible with lead free assembly

### Applications

- PCI Express
- Ethernet, GbE, Synchronous Ethernet
- Fiber Channel
- Enterprise Servers
- Telecom
- Clock source for A/D's, D/A's
- Driving FPGA's
- Test and Measurement
- PON
- Medical
- COTS

### Block Diagram

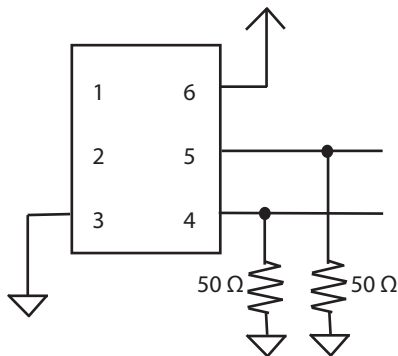


# Performance Specifications

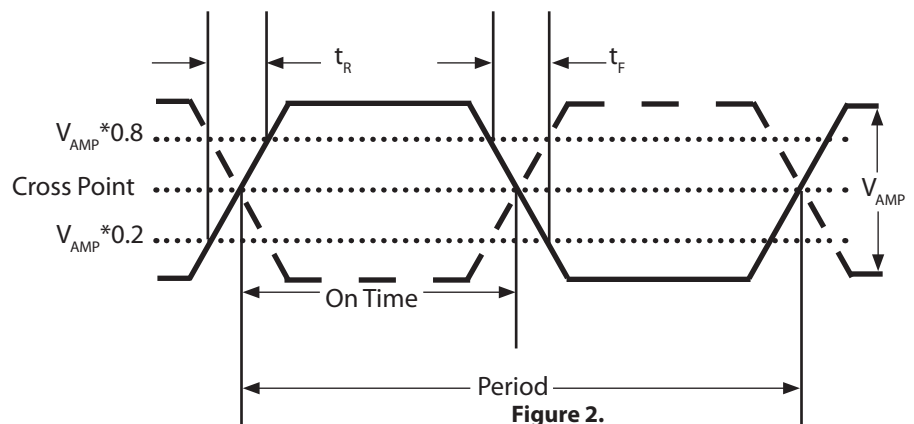
**Table 1. Electrical Performance, HCSL Output**

Parameter	Symbol	Min	Typical	Maximum	Units
<b>Supply</b>					
Voltage <sup>1</sup>	$V_{DD}$	2.25		3.60	V
Current (No Load)	$I_{DD}$			42	mA
<b>Frequency</b>					
Nominal Frequency	$f_N$	10		460	MHz
Stability <sup>2</sup> (Ordering Options)			$\pm 10, \pm 25, \pm 50$		ppm
<b>Outputs</b>					
Output Logic Levels Output Logic High Output Logic Low	$V_{OH}$ $V_{OL}$	0.725		0.1	V V
Output Rise and Fall Time <sup>3</sup> Rise Time Fall Time	$t_R$ $t_F$			400 400	ps ps
Load		50 ohms to ground			
Duty Cycle <sup>4</sup>		48		52	%
Jitter (200 kHz - 20 MHz) 156.250MHz <sup>5</sup> 12kHz-20MHz	$\phi J$		280 1.7		fs ps
Period Jitter <sup>6</sup> RMS P/P	$\phi J$		3.9 28		ps ps
<b>Enable/Disable</b>					
Output Enabled <sup>7</sup> Output Disabled	$V_{IH}$ $V_{IL}$	$0.75 * V_{DD}$		$0.25 * V_{DD}$	V V
Disable Time	$t_D$			5	ns
Enable/Disable Leakage Current	$I_{E/D}$			$\pm 200$	$\mu A$
Start-Up Time	$t_{SU}$			5	ms
Operating Temp. (Ordering Option)	$T_{OP}$	-10/70 or -40/85			$^{\circ}C$
Package Size		5.0 x 7.0 x 0.9			mm

1. The VM-822 power supply pin should be filtered, e.g., a 0.1 and 0.01 uf capacitor.
2. Includes calibration tolerance, operating temperature, supply voltage variations, aging and IR reflow.
3. Figure 1 defines the test circuit and Figure 2 defines these parameters.
4. Duty Cycle is defined as the On Time/Period.
5. Measured using an Agilent E5052.
6. Measured using a Wavecrest SIA3300C, 90K samples.
7. Outputs will be Enabled if the Enable/Disable pad is left open.



**Figure 1.**



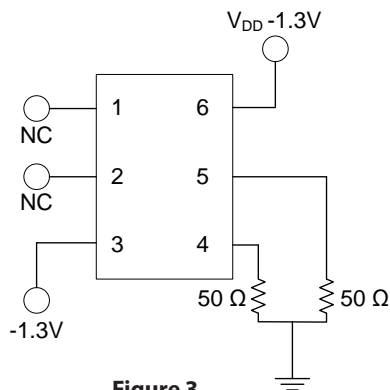
**Figure 2.**

# Performance Specifications

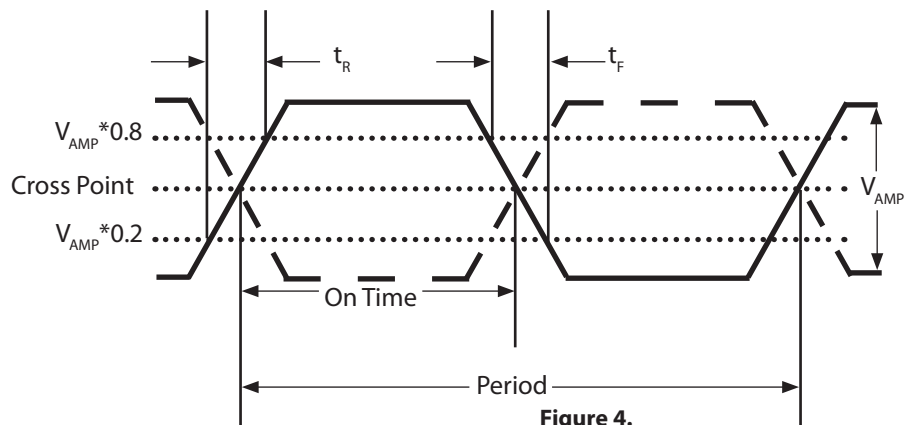
**Table 2. Electrical Performance, LVPECL Option**

Parameter	Symbol	Min	Typical	Maximum	Units
<b>Supply</b>					
Voltage <sup>1</sup>	$V_{DD}$	2.25		3.60	V
Current (No Load)	$I_{DD}$			32	mA
<b>Frequency</b>					
Nominal Frequency	$f_N$	10		460	MHz
Stability <sup>3</sup> (Ordering Option)			$\pm 10, \pm 25, \pm 50$		ppm
<b>Outputs</b>					
Output Logic Levels <sup>4</sup> Output Logic High Output Logic Low	$V_{OH}$ $V_{OL}$	$V_{DD}-1.08$		$V_{DD}-1.555$	V V
Output Rise and Fall Time <sup>3</sup>	$t_R/t_F$				ps
Load		50 ohms into $V_{DD}-1.3V$			
Duty Cycle <sup>4</sup>		48		52	%
Jitter, 156.250MHz <sup>5</sup> 200kHz-20MHz 12kHz-20MHz	$\phi J$		280 1.7		fs ps
Period Jitter <sup>6</sup> RMS P/P	$\phi J$		3.9 28		ps ps
<b>Enable/Disable</b>					
Output Enabled <sup>7</sup> Output Disabled	$V_{IH}$ $V_{IL}$	$0.75*V_{DD}$		$0.25*V_{DD}$	V V
Disable Time	$t_D$			5	ns
Enable/Disable Leakage Current				$\pm 200$	$\mu A$
Start-Up Time	$t_{SU}$			5	ms
Operating Temp. (Ordering Option)	$T_{OP}$	$-10/70$ or $-40/85$			$^{\circ}C$
Package Size		5.0 x 7.0 x 0.9			mm

1. The VM-822 power supply pin should be filtered, eg, a 0.1 and 0.01uf capacitor.
2. Includes calibration tolerance, operating temperature, supply voltage variations, aging and IR reflow.
3. Figure 3 defines the test circuit and Figure 4 defines these parameters.
4. Duty Cycle is defined as the On/Time Period.
5. Measured using an Agilent E5052.
6. Measured using a Wavecrest SIA3300C, 90K samples.
7. Outputs will be Enabled if Enable/Disable is left open.



**Figure 3.**



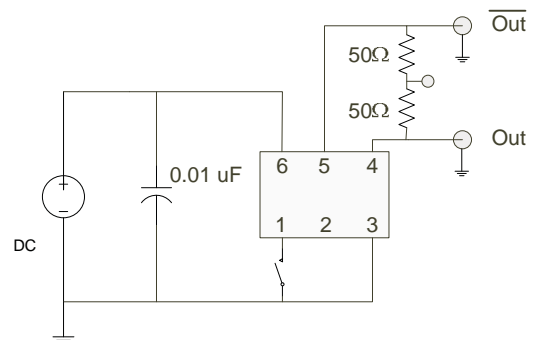
**Figure 4.**

# Performance Specifications

**Table 3. Electrical Performance, LVDS Option**

Parameter	Symbol	Min	Typical	Maximum	Units
<b>Supply</b>					
Voltage <sup>1</sup>	$V_{DD}$	2.25		3.60	V
Current (No Load)	$I_{DD}$			60	mA
<b>Frequency</b>					
Nominal Frequency	$f_N$	10		460	MHz
Stability <sup>2</sup> (Ordering Option)		±10, ±25, ±50			ppm
<b>Outputs</b>					
Output Logic Levels <sup>3</sup>					
Output Logic High	$V_{OH}$		1.43	1.6	V
Output Logic Low	$V_{OL}$	0.9	1.10		V
Differential Output Amplitude		250	350	450	mV
Differential Output Error				50	mV
Offset Voltage		1.125	1.25	1.4	V
Offset Voltage Error				50	mV
Output Leakage Current				10	uA
Output Rise and Fall Time <sup>3</sup>	$t_R/t_F$			400	ps
Load		100 ohms differential			
Duty Cycle <sup>4</sup>		48	50	52	%
Jitter, 156.250MHz <sup>5</sup>	$\phi J$				
200kHz - 2 0MHz			280		fs
12kHz - 20MHz			1.7		ps
Period Jitter <sup>6</sup>	$\phi J$				
RMS			3.9		ps
P/P			28		ps
<b>Enable/Disable</b>					
Output Enabled <sup>7</sup>	$V_{IH}$	$0.75 * V_{DD}$			V
Output Disabled	$V_{IL}$			$0.25 * V_{DD}$	V
Disable Time	$t_D$			5	ns
Enable/Disable Leakage Current	$I_{E/D}$			±200	uA
Start-Up Time	$t_{SU}$			5	ms
Operating Temp. (Ordering Option)	$T_{OP}$	-10/70 or -40/85			°C
Package Size		5.0 x 7.0 x 0.9			mm

1. The VM-822 power supply pin should be filtered, eg, a 0.1 and 0.01 uF capacitor.
2. Includes calibration tolerance, operating temperature, supply voltage variations, aging and IR reflow.
3. Figure 5 defines these parameters and Figure 4 defines the test circuit.
4. Duty Cycle is defined as the On/Time Period.
5. Measured using an Agilent E5052.
6. Measured using a Wavecrest SIA3300C, 90K samples.
7. Outputs will be Enabled if Enable/Disable is left open.



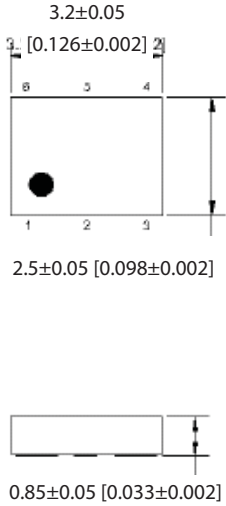
**Figure 5.**

# Package and Pinout

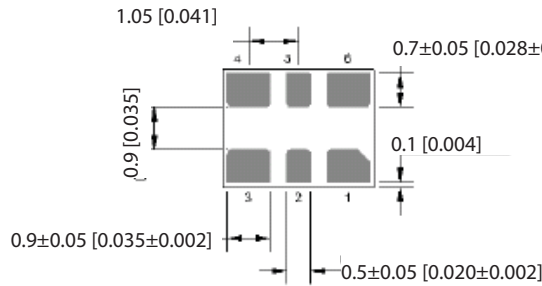
**Table 4. Pinout**

Pin #	Symbol	Function
1	E/D or NC	Enable/Disable
2	NC	No Connection
3	GND	Electrical and Lid Ground
4	$f_o$	Output Frequency
5	$Cf_o$	Complementary Output Frequency
6	$V_{DD}$	Supply Voltage

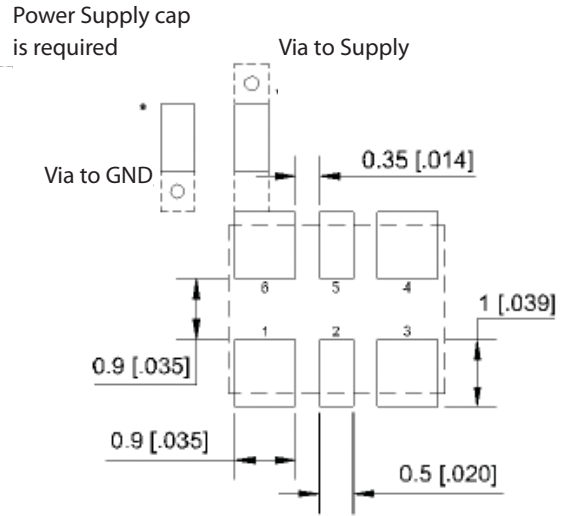
Contact Pads are Gold flash (0.003 um min ) over Palladium (0.01-0.15um) over Nickel (0.508-2.032um)



**Figure 6. Package Outline Drawing**

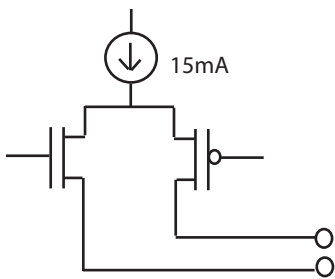


Units: mm (inches)

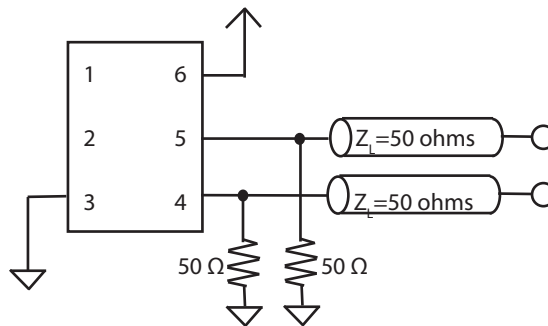


**Figure 7. Pad Layout**

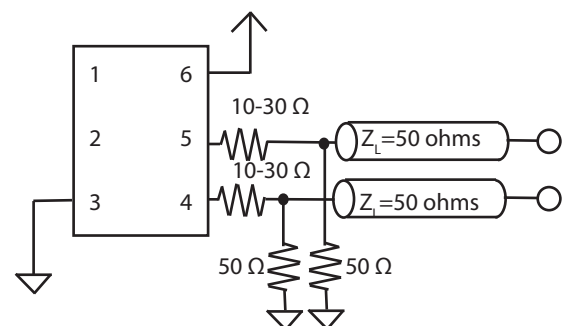
# HCSL Application Diagrams



**Figure 8. Standard HCSL Output Configuration**



**Figure 9. Single Resistor Termination Scheme**

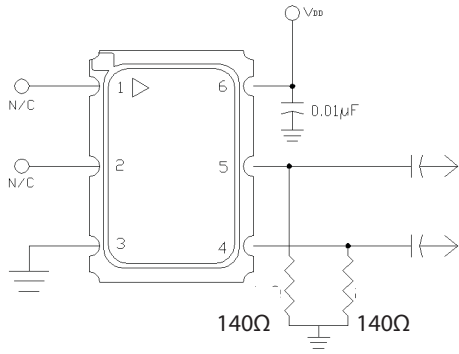


**Figure 10. In some cases a 10-30 ohm series resistor is used to help reduce overshoot.**

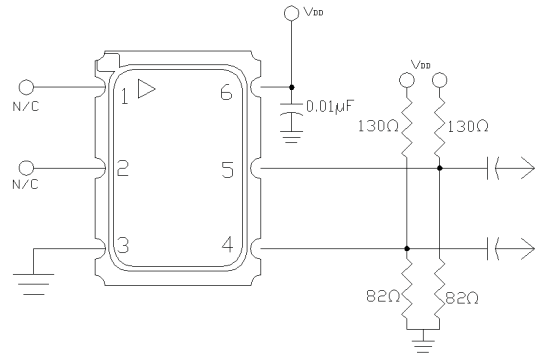
The VM-822 incorporates a standard High Speed Current Logic, HCSL, output scheme which is a 15mA current source switched between Out and Complementary Out. Being un-terminated drains, as shown in Figure 8, they require external 50 ohm resistors to ground as shown in Figure 9. HCSL is a high impedance output with quick switching times, in can be advantageous to use a 10 to 30 ohm series resistor as shown in Figure 10, to help reduce overshoot/ringing.

One of the most important considerations is terminating the Output and Complementary Outputs equally. An unused output should not be left un-terminated, and if it one of the two outputs is left open it will result in excessive jitter on both. PC board layout must take this and 50 ohm impedance matching into account. Load matching and power supply noise are the main contributors to jitter related problems.

## LVPECL Application Diagrams



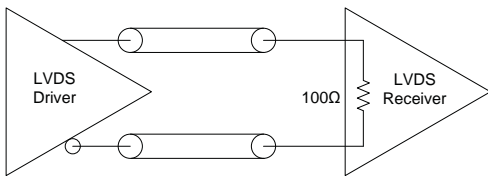
**Figure 11. Single Resistor Termination Scheme**  
Resistor values are typically 140 ohms for 3.3V operation and 82.5ohms for 2.5V operation.



**Figure 12. Pull-Up Pull Down Termination**  
Resistor values are typically for 3.3V operation  
For 2.5V operation, the resistor to ground is 62 ohms and the resistor to supply is 250 ohms

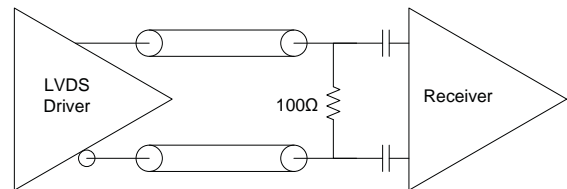
The VM-822 incorporates a standard LVPECL output scheme, which are un-terminated emitters as shown in Figure 8. There are numerous application notes on terminating and interfacing LVPECL logic and the two most common methods are a single resistor to ground, Figure 9, and a pull-up/pull-down scheme as shown in Figure 10. An AC coupling capacitor is optional, depending on the application and the input logic requirements of the next stage.

## LVDS Application Diagrams



**Figure 13. LVDS to LVDS Connection, Internal 100ohm**

Some LVDS structures have an internal 100 ohm resistor on the input and do not need additional components.



**Figure 14. LVDS to LVDS Connection  
External 100ohm and AC blocking caps**

Some input structures may not have an internal 100 ohm resistor on the input and will need an external 100ohm resistor for impedance matching. Also, the input may have an internal DC bias which may not be compatible with LVDS levels, AC blocking capacitors can be used.

One of the most important considerations is terminating the Output and Complementary Outputs equally. An unused output should not be left un-terminated, and if one of the two outputs is left open it will result in excessive jitter on both. PC board layout must take this and 50 ohm impedance matching into account. Load matching and power supply noise are the main contributors to jitter related problems.

## Environmental and IR Compliance

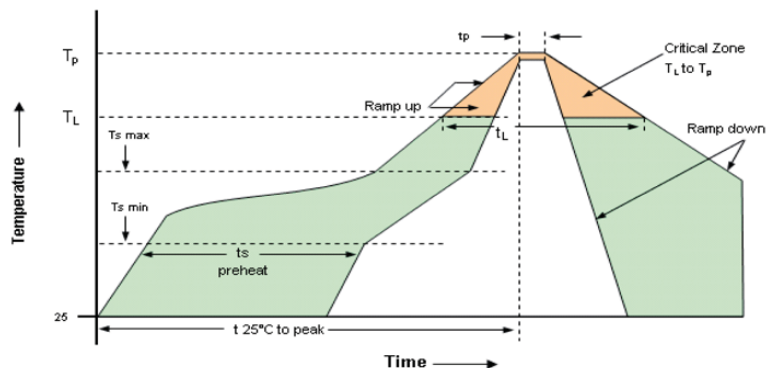
Table 5. Environmental Compliance	
Parameter	Condition
Mechanical Shock	MIL-STD-883 Method 2002
Mechanical Vibration	MIL-STD-883 Method 2007
Temperature Cycle	MIL-STD-883 Method 1010
Solderability	MIL-STD-883 Method 2003
Fine and Gross Leak	MIL-STD-883 Method 1014
Resistance to Solvents	MIL-STD-202 Method 215
Moisture Sensitivity Level	MSL1

## Suggested IR Profile

Devices are built using lead free epoxy and can be subjected to standard lead free IR reflow conditions shown in Table 6. Contact pads are gold over nickel and lower maximum temperatures can also be used, such as 220C.

Parameter	Symbol	Value
PreHeat Time	$t_s$	200 sec Max
Ramp Up	$R_{UP}$	3°C/sec Max
Time above 217°C	$t_L$	150 sec Max
Time to Peak Temperature	$t_{AMB-P}$	480 sec Max
Time at 260°C	$t_P$	30 sec Max
Time at 240°C	$t_{P2}$	60 sec Max
Ramp down	$R_{DN}$	6°C/sec Max

Solderprofile:



## Maximum Ratings, Tape & Reel

### Absolute Maximum Ratings and Handling Precautions

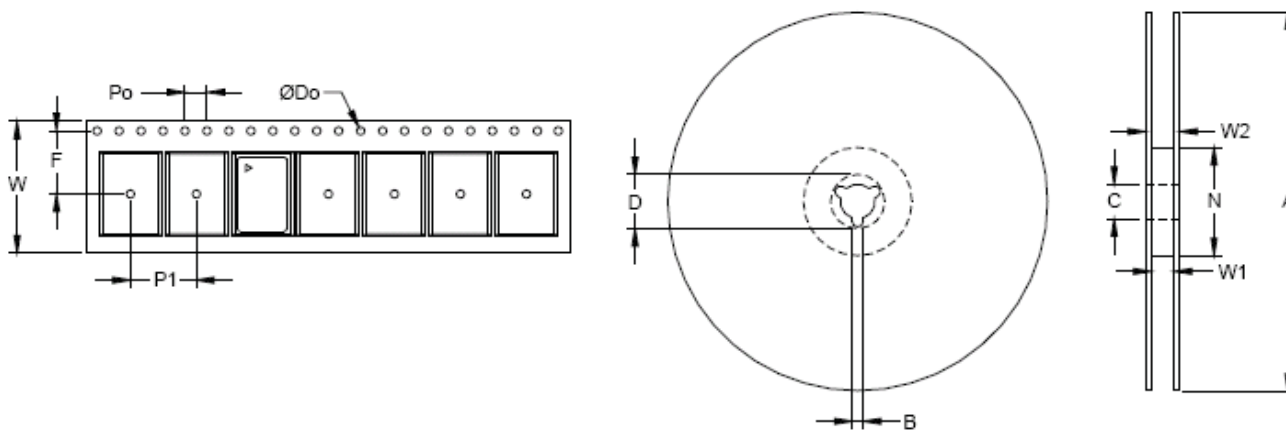
Stresses in excess of the absolute maximum ratings can permanently damage the device. Functional operation is not implied or any other excess of conditions represented in the operational sections of this data sheet. Exposure to absolute maximum ratings for extended periods may adversely affect device reliability.

Although ESD protection circuitry has been designed into the VM-822, proper precautions should be taken when handling and mounting, VI employs a Human Body Model and Charged Device Model for ESD susceptibility testing and design evaluation. ESD thresholds are dependent on the circuit parameters used to define the model. Although no industry standard has been adopted for the CDM a standard resistance of 1.5kOhms and capacitance of 100pF is widely used and therefor can be used for comparison purposes.

Parameter		Unit
Storage Temperature	-55 to 125	°C
Junction Temperature	150	C
Supply Voltage	-0.5 to 5.0	V
Enable Disable Voltage	-0.5 to $V_{DD}+0.5$	V
ESD, Human Body Model	1500	V
ESD, Charged Device Model	1500	V

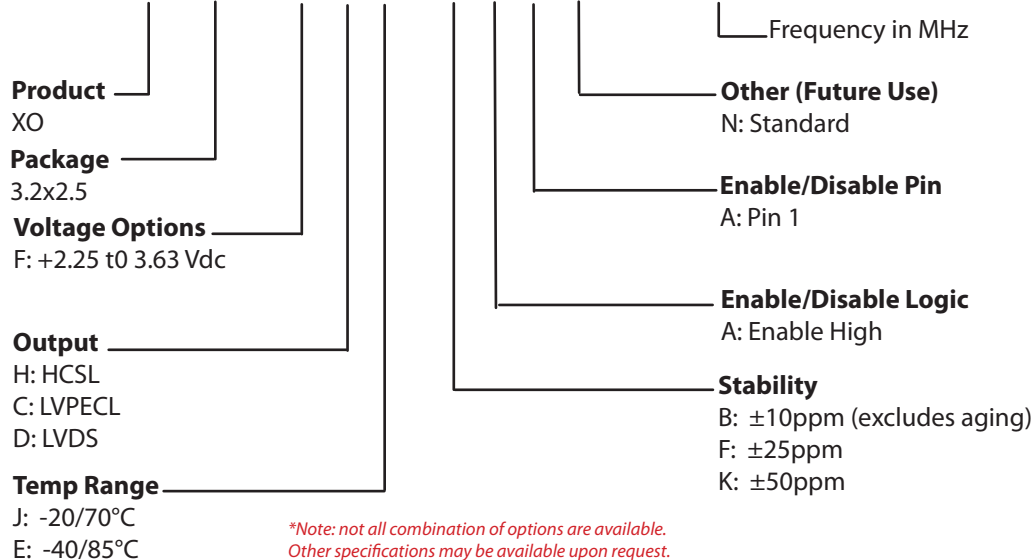
Table 8. Tape and Reel Information

Tape Dimensions (mm)					Reel Dimensions (mm)							
W	F	Do	Po	P1	A	B	C	D	N	W1	W2	#/Reel
12	5.5	1.5	4	4	180	2	13	21	60	13	15.4	1000/3000



## Ordering Information

### VM-822- F C E - K A A N - xxxMxxxxxx



**Example: VM-822-ECE-KAAN-156M250**

## For Additional Information, Please Contact

### USA:

Vectron International  
267 Lowell Road  
Hudson, NH 03051  
Tel: 1.888.328.7661  
Fax: 1.888.329.8328

### Europe:

Vectron International  
Landstrasse, D-74924  
Neckarbischofsheim, Germany  
Tel: +49 (0) 3328.4784.17  
Fax: +49 (0) 3328.4784.30

### Asia:

VI Shanghai  
1589 Century Avenue, the 19th Floor  
Chamtime International Financial Center  
Shanghai, China  
Tel: 86.21.6081.2888  
Fax: 86.21.6163.3598

### Disclaimer

Vectron International reserves the right to make changes to the product(s) and or information contained herein without notice. No liability is assumed as a result of their use or application. No rights under any patent accompany the sale of any such product(s) or information.

Rev: 06/22/2011