

Thermally-Enhanced High Power RF LDMOS FET 280 W, 30 V, 791 – 821 MHz

Description

The PTFB082817FH is a LDMOS FET intended for use in multi-standard cellular power amplifier applications. Features include input and output matching, high gain and thermally-enhanced package with earless flanges. Manufactured with Infineon's advanced LDMOS process, this device provides excellent thermal performance and superior reliability.

PTFB082817FH
Package H-34288-4/2

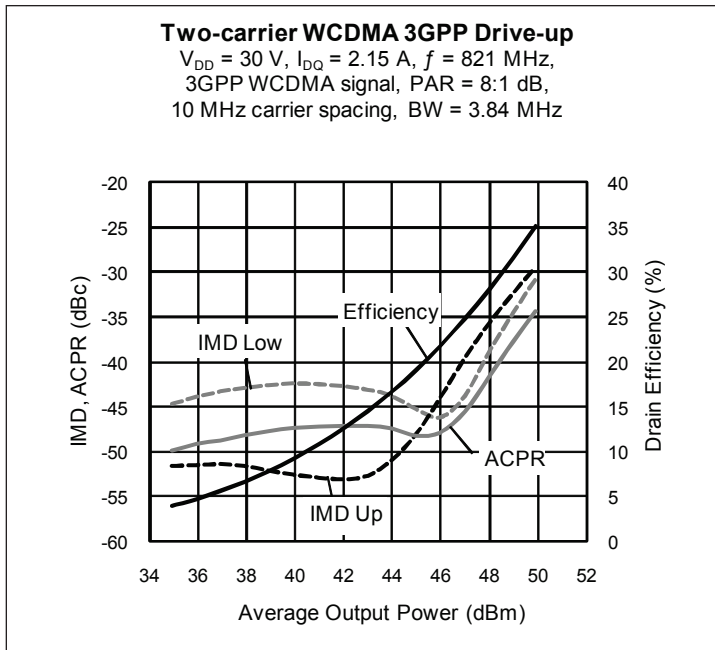

Features

- Broadband internal matching
- Enhanced for use in DPD error correction systems
- Typical single-carrier WCDMA performance at 821 MHz, 30 V
 - Average output power = 50 W
 - Linear Gain = 19 dB
 - Efficiency = 35 %
 - Adjacent channel power = -35 dBc
- Increased negative gate-source voltage range for improved performance in Doherty peaking amplifiers
- Integrated ESD protection
- Capable of handling 10:1 VSWR @ 30 V, 280 W (CW) output power
- Pb-Free and RoHS compliant

RF Characteristics

Two-carrier WCDMA Specifications (tested in Infineon test fixture)

$V_{DD} = 28\text{ V}$, $I_{DQ} = 2.15\text{ A}$, $P_{OUT} = 60\text{ W}$ average, $f = 821\text{ MHz}$, 3GPP signal, 10 MHz spacing, channel bandwidth = 3.84 MHz, peak/average = 8 : 1 dB @ 0.01% CCDF

Characteristic	Symbol	Min	Typ	Max	Unit
Gain	G_{ps}	18.5	19.3	—	dB
Drain Efficiency	η_D	28	29	—	%
Intermodulation Distortion	IMD	—	-36	-34	dBc

All published data at $T_{CASE} = 25^\circ\text{C}$ unless otherwise indicated

ESD: Electrostatic discharge sensitive device—observe handling precautions!

DC Characteristics

Characteristic	Conditions	Symbol	Min	Typ	Max	Unit
Drain-Source Breakdown Voltage	$V_{GS} = 0\text{ V}$, $I_{DS} = 10\text{ mA}$	$V_{(BR)DSS}$	65	—	—	V
Drain Leakage Current	$V_{DS} = 28\text{ V}$, $V_{GS} = 0\text{ V}$	I_{DSS}	—	—	1.0	μA
Drain Leakage Current	$V_{DS} = 63\text{ V}$, $V_{GS} = 0\text{ V}$	I_{DSS}	—	—	10.0	μA
On-State Resistance	$V_{GS} = 10\text{ V}$, $V_{DS} = 0.1\text{ V}$	$R_{DS(on)}$	—	0.05	—	Ω
Operating Gate Voltage	$V_{DS} = 28\text{ V}$, $I_{DQ} = 2.15\text{ A}$	V_{GS}	2.5	3.9	4.5	V
Gate Leakage Current	$V_{GS} = 10\text{ V}$, $V_{DS} = 0\text{ V}$	I_{GSS}	—	—	1.0	μA

Maximum Ratings

Parameter	Symbol	Value	Unit
Drain-Source Voltage	V_{DSS}	65	V
Gate-Source Voltage	V_{GS}	-6 to +10	V
Junction Temperature	T_J	200	$^{\circ}\text{C}$
Storage Temperature Range	T_{STG}	-40 to +150	$^{\circ}\text{C}$
Thermal Resistance ($T_{CASE} = 70^{\circ}\text{C}$, 250 W CW)	$R_{\theta JC}$	0.215	$^{\circ}\text{C/W}$

Ordering Information

Type and Version	Package Outline	Package Description	Shipping
PTFB082817FH V1	H-34288-4/2	Ceramic open-cavity, earless flange	Tray
PTFB082817FH V1 R250	H-34288-4/2	Ceramic open-cavity, earless flange	Tape & Reel

Typical Performance (data taken in a production test fixture)

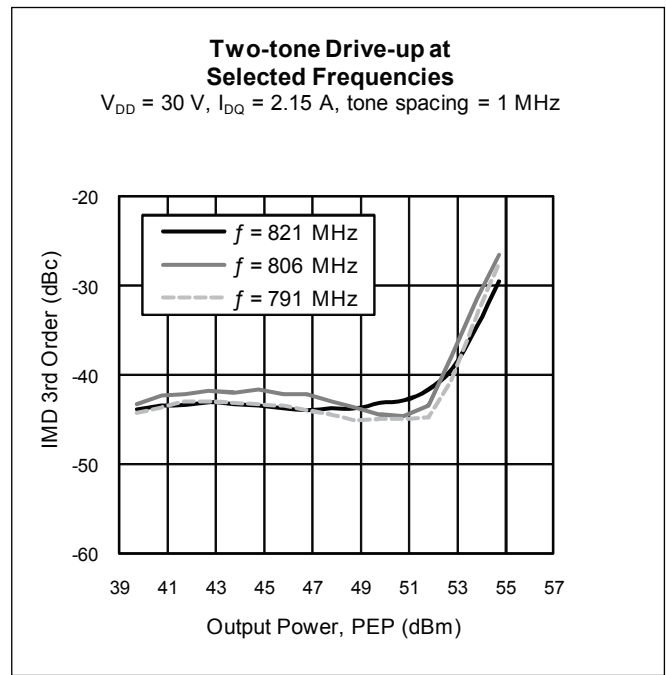
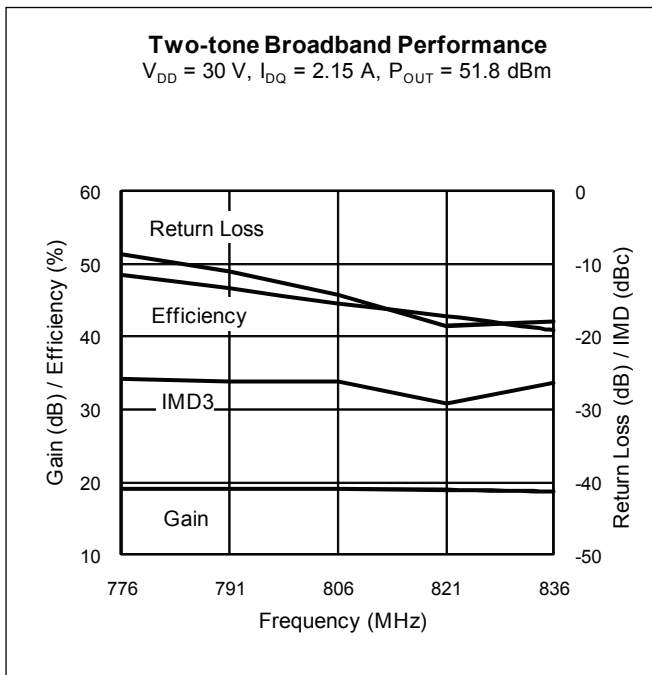
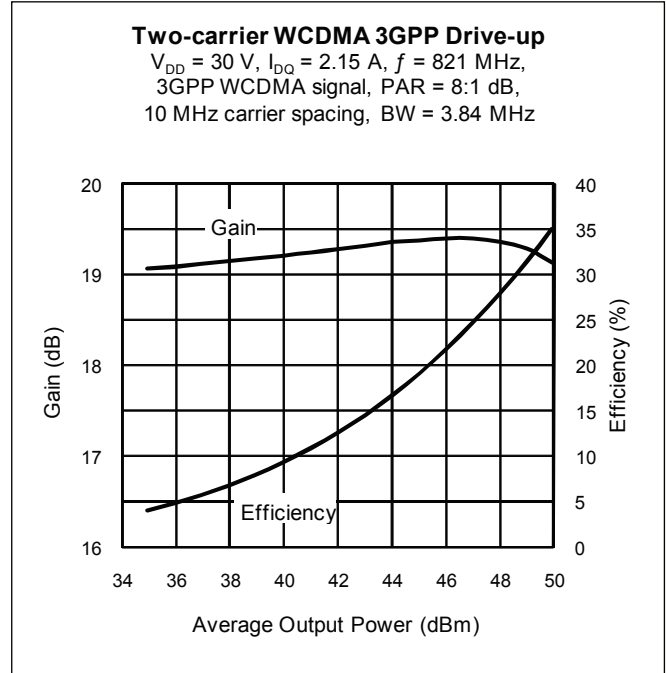
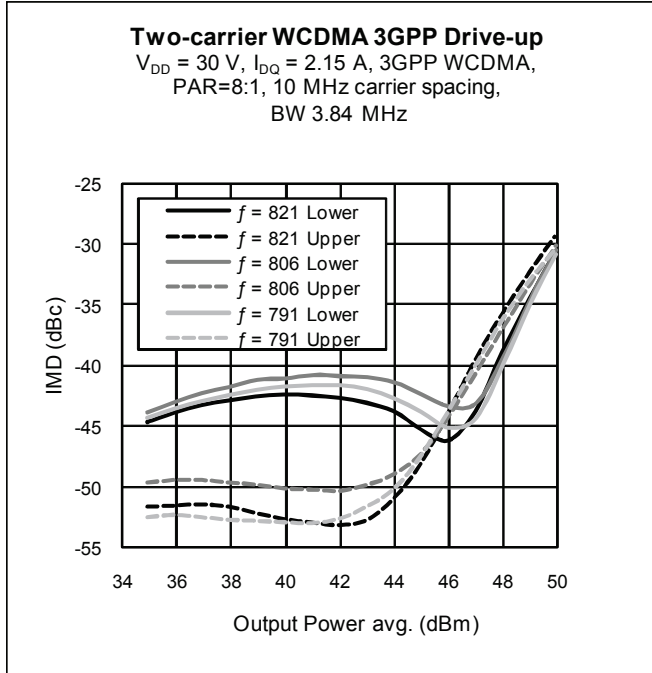

Typical Performance (cont.)

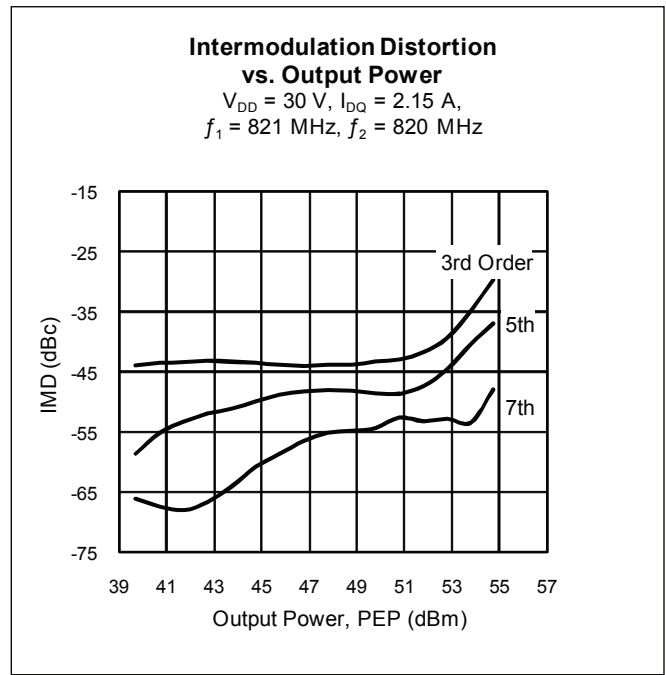
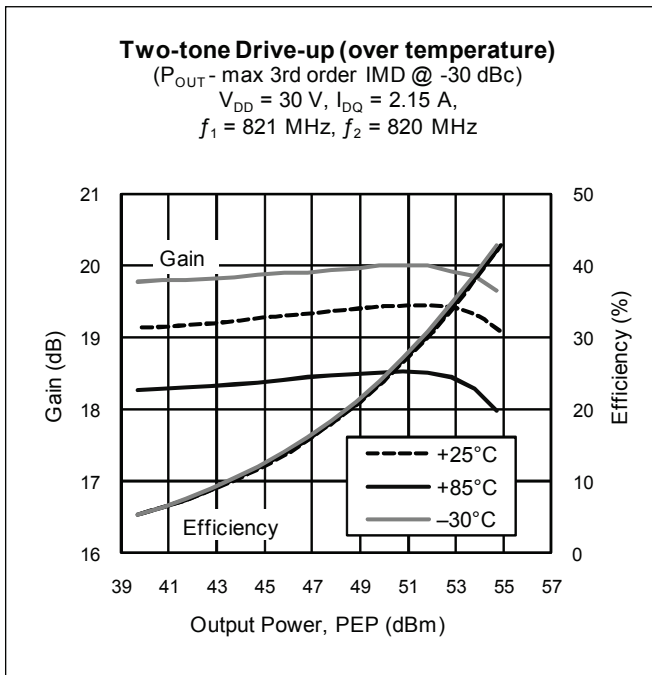
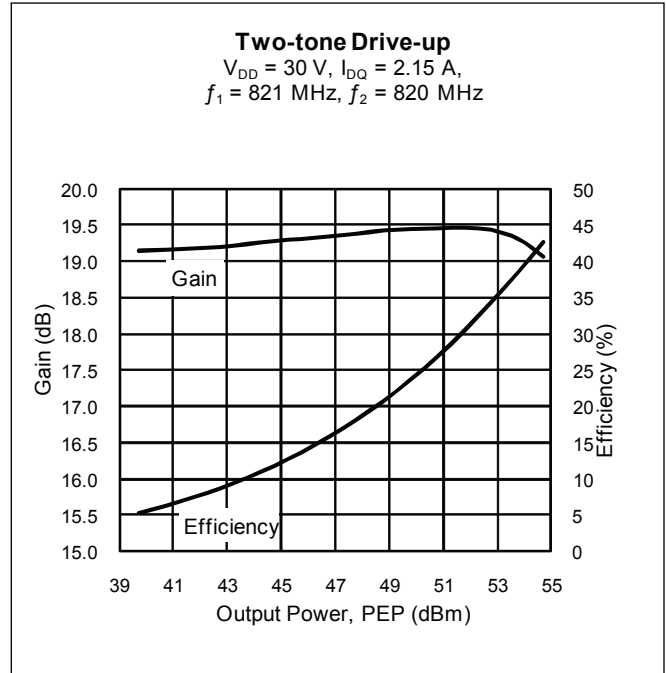
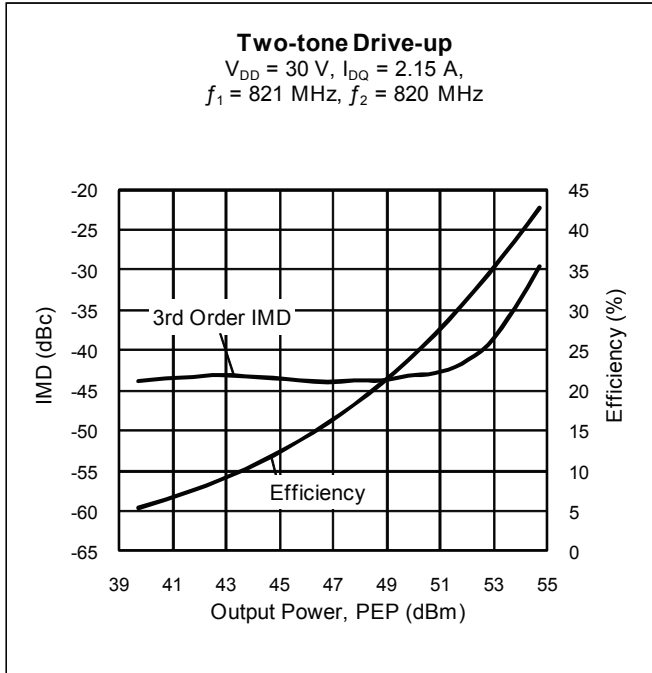

Typical Performance (cont.)

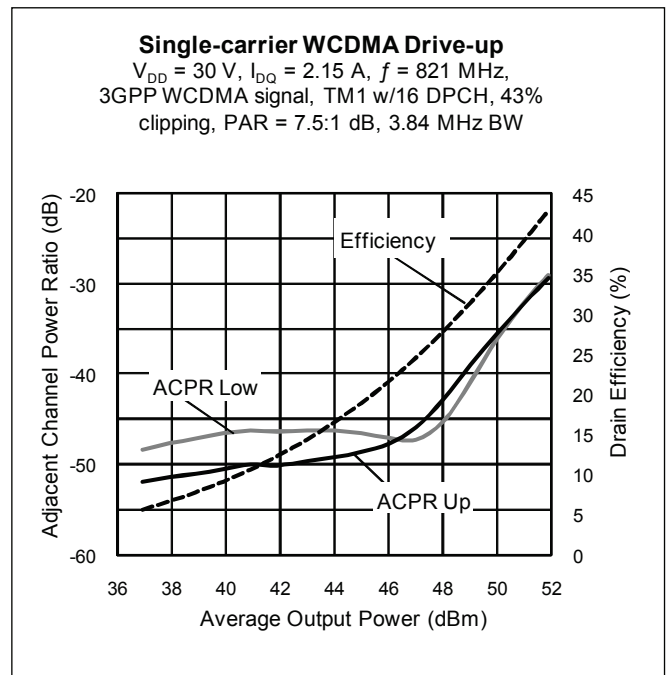
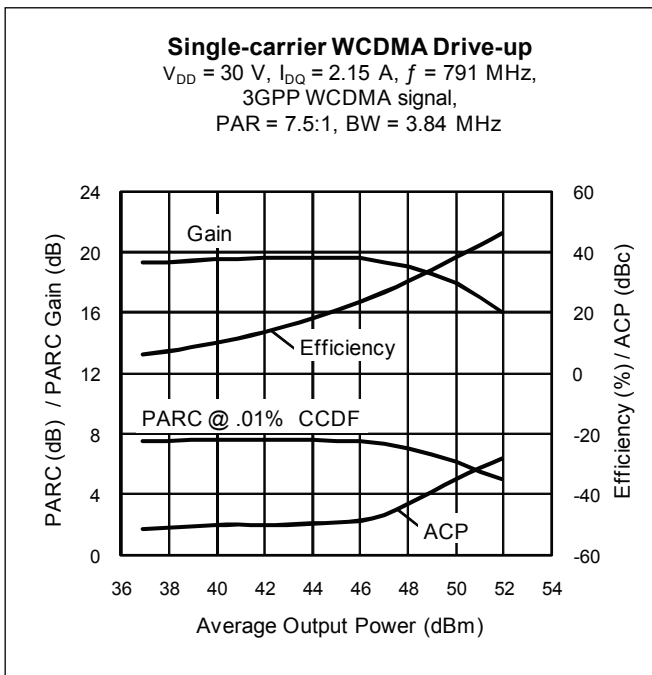
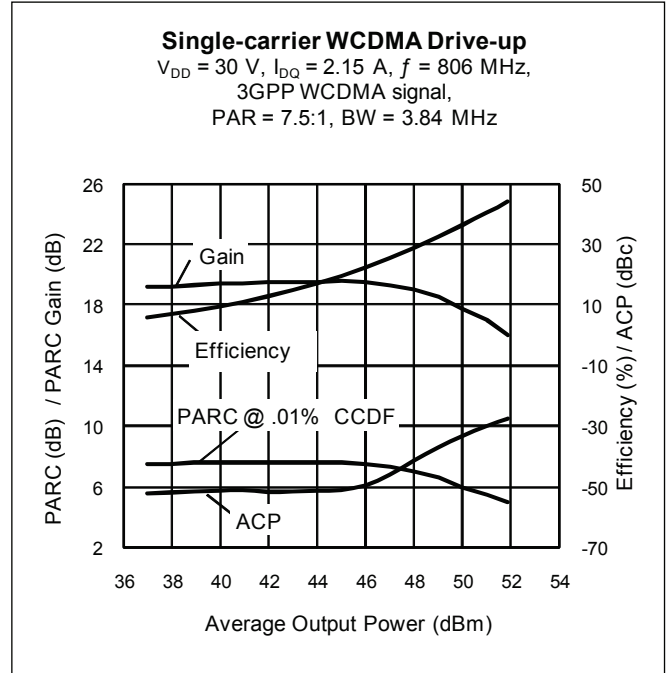
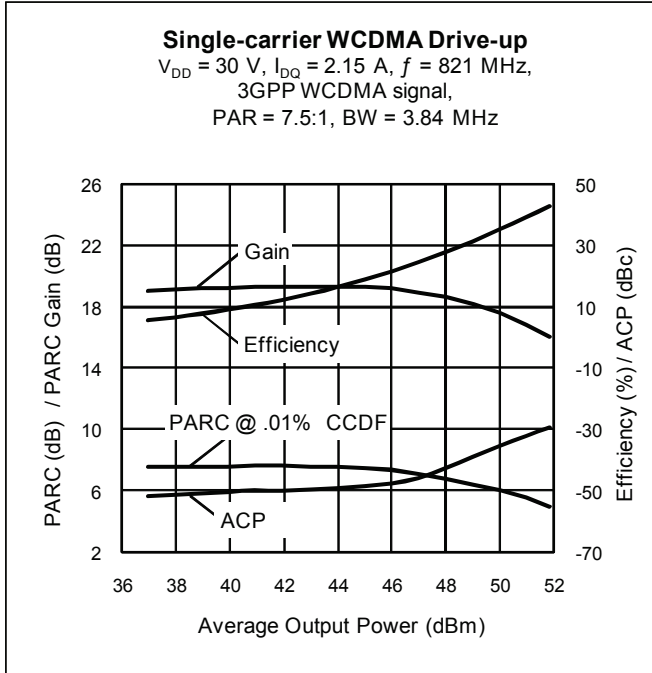

Broadband Circuit Impedance

Frequency MHz	Z Source Ω		Z Load Ω	
	R	jX	R	jX
776	0.92	-1.83	0.96	-1.55
791	0.89	-1.75	0.91	-1.49
806	0.86	-1.68	0.85	-1.42
821	0.83	-1.60	0.79	-1.34
836	0.79	-1.52	0.74	-1.25

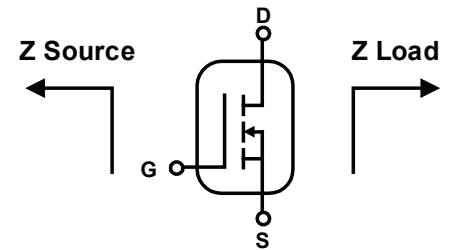

See next page for reference circuit information

Reference Circuit

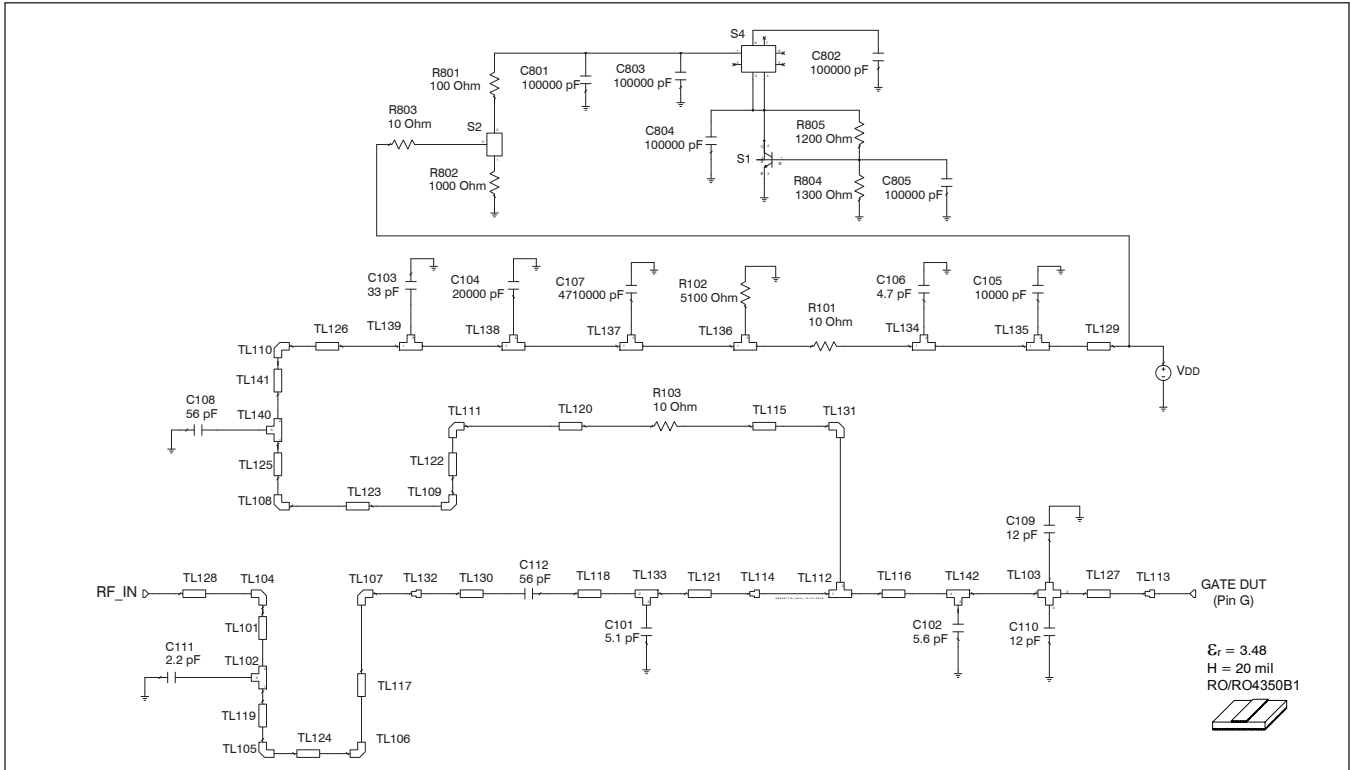

Reference circuit input schematic for $f = 821$ MHz

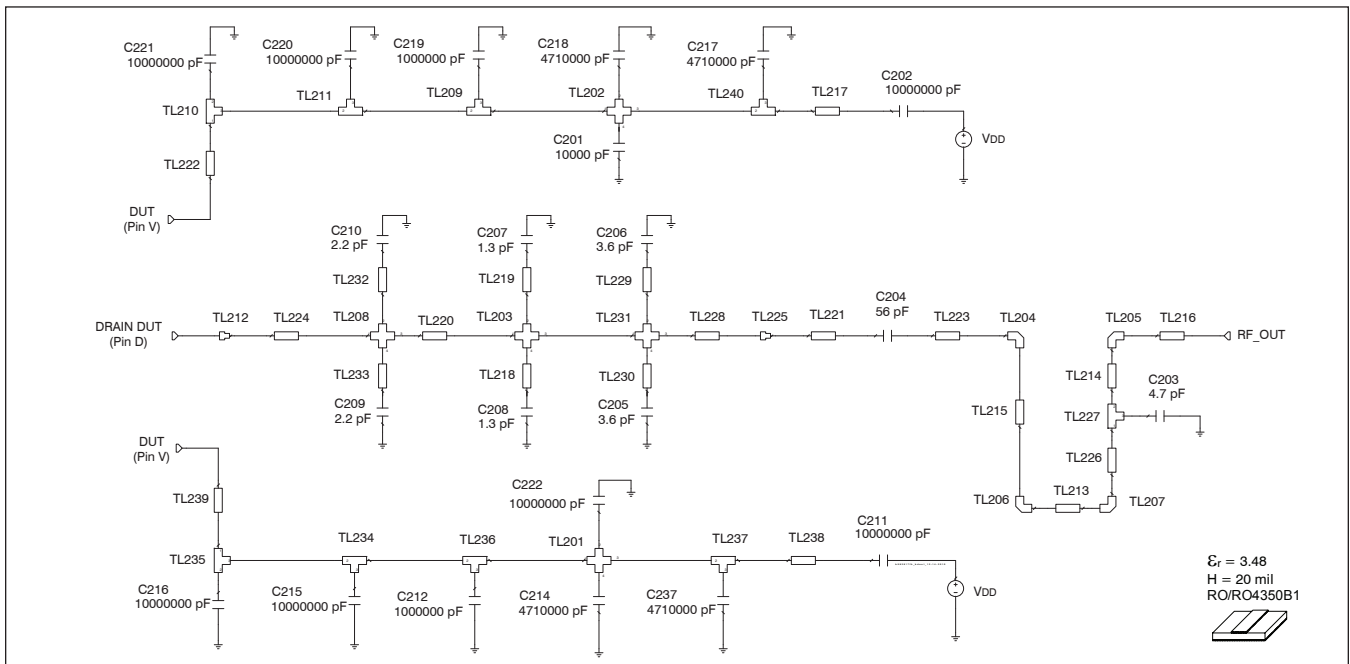

Reference circuit output schematic for $f = 821$ MHz

Reference Circuit (cont.)

Description

DUT	PTFB082817FH
PCB	0.508 mm [.020"] thick, $\epsilon_r = 3.48$, Rogers 4350, 1 oz. copper

Electrical Characteristics at 821 MHz

Transmission Line	Electrical Characteristics	Dimensions: mm	Dimensions: mils
Input			
TL101	0.005 λ , 51.46 Ω	W = 1.105, L = 1.168	W = 44, L = 46
TL102	0.008 λ , 51.46 Ω	W1 = 1.105, W2 = 1.105, W3 = 1.778	W1 = 44, W2 = 44, W3 = 70
TL103		W1 = 17.780, W2 = 1.778, W3 = 17.780, W4 = 2.032	W1 = 700, W2 = 70, W3 = 700, W4 = 80
TL104, TL105, TL106, TL107		W = 1.105	W = 44
TL108, TL109, TL110, TL111, TL131		W = 0.762	W = 30
TL112	0.004 λ , 5.33 Ω	W1 = 17.780, W2 = 17.780, W3 = 0.762	W1 = 700, W2 = 700, W3 = 30
TL113		W1 = 17.780, W2 = 12.700	W1 = 700, W2 = 500
TL114		W1 = 1.676, W2 = 17.780	W1 = 66, W2 = 700
TL115	0.002 λ , 63.89 Ω	W = 0.762, L = 0.508	W = 30, L = 20
TL116	0.043 λ , 5.33 Ω	W = 17.780, L = 8.636	W = 700, L = 340
TL117	0.036 λ , 51.46 Ω	W = 1.105, L = 8.001	W = 44, L = 315
TL118	0.007 λ , 39.10 Ω	W = 1.676, L = 1.511	W = 66, L = 60
TL119	0.023 λ , 51.46 Ω	W = 1.105, L = 5.055	W = 44, L = 199
TL120	0.006 λ , 63.89 Ω	W = 0.762, L = 1.270	W = 30, L = 50
TL121	0.054 λ , 39.10 Ω	W = 1.676, L = 11.722	W = 66, L = 462
TL122	0.013 λ , 63.89 Ω	W = 0.762, L = 2.921	W = 30, L = 115
TL123	0.085 λ , 63.89 Ω	W = 0.762, L = 19.050	W = 30, L = 750
TL124	0.005 λ , 51.46 Ω	W = 1.105, L = 1.016	W = 44, L = 40
TL125	0.002 λ , 63.89 Ω	W = 0.762, L = 0.559	W = 30, L = 22
TL126	0.006 λ , 26.81 Ω	W = 2.794, L = 1.270	W = 110, L = 50
TL127	0.038 λ , 5.33 Ω	W = 17.780, L = 7.645	W = 700, L = 301
TL128	0.034 λ , 51.46 Ω	W = 1.105, L = 7.574	W = 44, L = 298
TL129	0.001 λ , 26.81 Ω	W = 2.794, L = 0.254	W = 110, L = 10
TL130	0.006 λ , 39.10 Ω	W = 1.676, L = 1.270	W = 66, L = 50
TL132		W1 = 1.676, W2 = 1.105	W1 = 66, W2 = 44
TL133	0.009 λ , 39.10 Ω	W1 = 1.676, W2 = 1.676, W3 = 2.032	W1 = 66, W2 = 66, W3 = 80
TL134, TL135, TL136, TL137	0.012 λ , 26.81 Ω	W1 = 2.794, W2 = 2.794, W3 = 2.540	W1 = 110, W2 = 110, W3 = 100
TL138, TL139	0.010 λ , 26.81 Ω	W1 = 2.794, W2 = 2.794, W3 = 2.032	W1 = 110, W2 = 110, W3 = 80
TL140	0.009 λ , 63.89 Ω	W1 = 0.762, W2 = 0.762, W3 = 2.032	W1 = 30, W2 = 30, W3 = 80
TL141	0.011 λ , 63.89 Ω	W = 0.762, L = 2.492	W = 30, L = 98
TL142	0.010 λ , 5.33 Ω	W1 = 17.780, W2 = 17.780, W3 = 2.032	W1 = 700, W2 = 700, W3 = 80

Reference Circuit (cont.)

Electrical Characteristics at 821 MHz

Transmission Line	Electrical Characteristics	Dimensions: mm	Dimensions: mils
Output			
TL201, TL202		W1 = 3.810, W2 = 2.540, W3 = 3.810, W4 = 2.540	W1 = 150, W2 = 100, W3 = 150, W4 = 100
TL203, TL231		W1 = 16.510, W2 = 2.032, W3 = 16.510, W4 = 2.032	W1 = 650, W2 = 80, W3 = 650, W4 = 80
TL204, TL205, TL206, TL207		W = 1.105	W = 44
TL208		W1 = 16.510, W2 = 1.829, W3 = 16.510, W4 = 1.829	W1 = 650, W2 = 72, W3 = 650, W4 = 72
TL209, TL236, TL237, TL240	0.012 λ , 20.93 Ω	W1 = 3.810, W2 = 3.810, W3 = 2.540	W1 = 150, W2 = 150, W3 = 100
TL210, TL235	0.018 λ , 16.47 Ω	W1 = 5.080, W2 = 5.080, W3 = 3.810	W1 = 200, W2 = 200, W3 = 150
TL211	0.000 λ , 20.93 Ω	W1 = 3.810, W2 = 3.810, W3 = 0.025	W1 = 150, W2 = 150, W3 = 1
TL212		W1 = 16.510, W2 = 12.700	W1 = 650, W2 = 500
TL213	0.005 λ , 51.46 Ω	W = 1.105, L = 1.143	W = 44, L = 45
TL214	0.011 λ , 51.46 Ω	W = 1.105, L = 2.489	W = 44, L = 98
TL215	0.051 λ , 51.46 Ω	W = 1.105, L = 11.303	W = 44, L = 445
TL216	0.014 λ , 51.46 Ω	W = 1.105, L = 3.025	W = 44, L = 119
TL217, TL238	0.063 λ , 20.93 Ω	W = 3.810, L = 13.183	W = 150, L = 519
TL218, TL219, TL229, TL230, TL232, TL233	0.000 λ , 36.77 Ω	W = 1.829, L = 0.025	W = 72, L = 1
TL220	0.036 λ , 5.71 Ω	W = 16.510, L = 7.214	W = 650, L = 284
TL221	0.007 λ , 39.10 Ω	W = 1.676, L = 1.524	W = 66, L = 60
TL222, TL239	0.014 λ , 16.47 Ω	W = 5.080, L = 2.896	W = 200, L = 114
TL223	0.009 λ , 39.10 Ω	W = 1.676, L = 2.032	W = 66, L = 80
TL224	0.033 λ , 5.71 Ω	W = 16.510, L = 6.604	W = 650, L = 260
TL225		W1 = 16.510, W2 = 1.676	W1 = 650, W2 = 66
TL226	0.031 λ , 51.46 Ω	W = 1.105, L = 6.782	W = 44, L = 267
TL227	0.009 λ , 51.46 Ω	W1 = 1.105, W2 = 1.105, W3 = 2.032	W1 = 44, W2 = 44, W3 = 80
TL228	0.094 λ , 5.71 Ω	W = 16.510, L = 18.796	W = 650, L = 740
TL234	0.000 λ , 20.93 Ω	W1 = 3.810, W2 = 3.810, W3 = 0.025	W1 = 150, W2 = 150, W3 = 1

Reference Circuit (cont.)

Circuit Assembly Information

Test Fixture Part No. LTN/PTFB082817FH

Find Gerber files for this test fixture on the Infineon Web site at <http://www.infineon.com/rfpower>

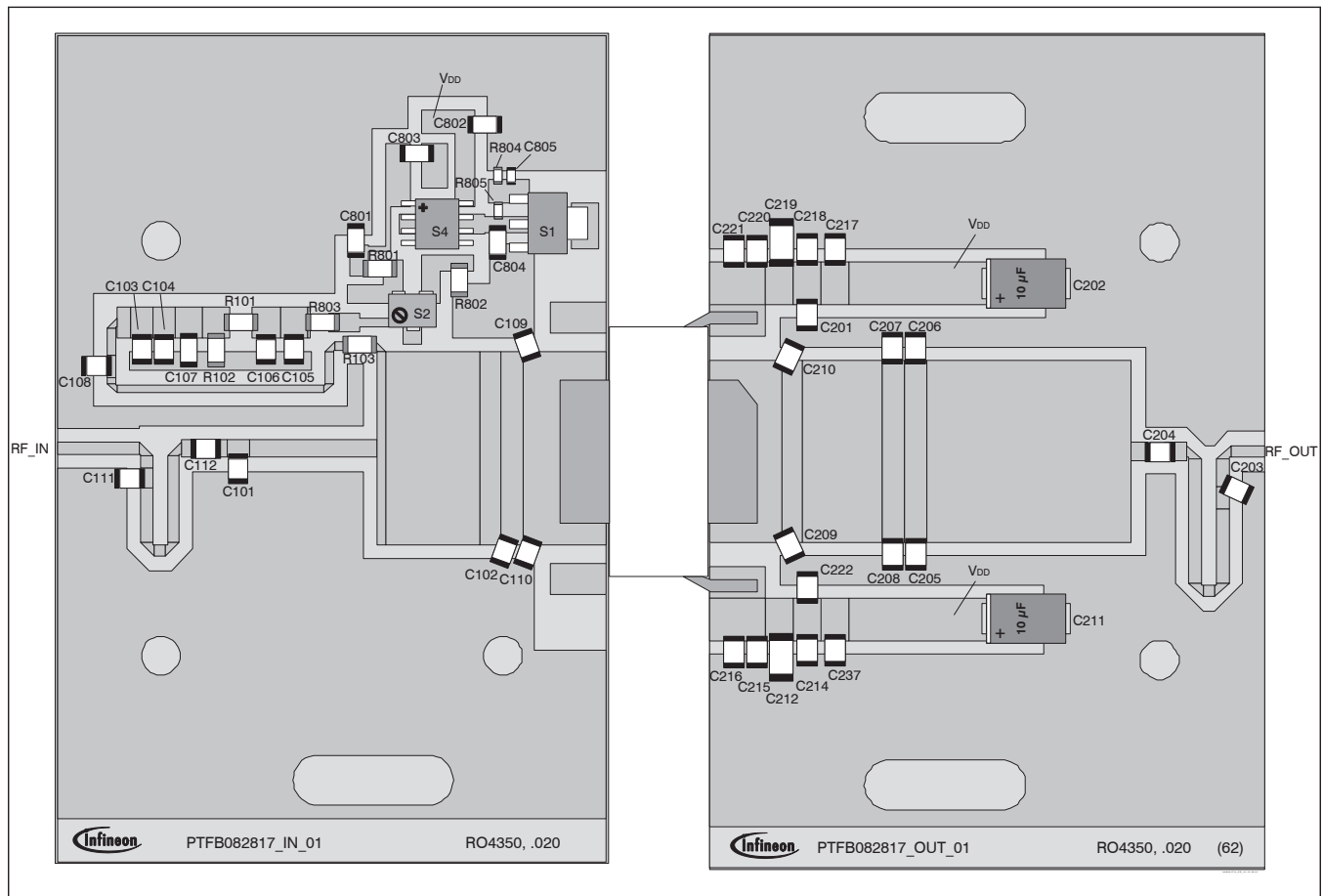

Reference circuit assembly diagram (not to scale)

Reference Circuit (cont.)

Components Information

Component	Description	Suggested Manufacturer	P/N
Input			
C101	Chip capacitor, 5.1 pF	ATC	ATC100B5R1CW
C102	Chip capacitor, 5.6 pF	ATC	ATC100B5R6CW
C103	Chip capacitor, 33 pF	ATC	ATC100B330JW
C104	Capacitor, 20000 pF	Digi-Key	ATC200B203MW
C105	Capacitor, 10000 pF	Digi-Key	ATC200B103MW
C106	Chip capacitor, 4.7 pF	ATC	ATC100B4R7CT
C107	Chip capacitor, 4.71 μ F	ATC	493-2372-2-ND
C108, C112	Chip capacitor, 56 pF	ATC	ATC100B560JT
C109	Chip capacitor, 12 pF	ATC	ATC100B120FW500XB
C110	Chip capacitor, 12 pF	ATC	ATC100B120JW
C111	Chip capacitor, 2.2 pF	ATC	ATC100B2R2CW
C801, C804	Chip capacitor, 0.1 μ F	ATC	PCC104BCT-ND
C802, C803, C805	Chip capacitor, 0.1 μ F	ATC	PCC1772CT-ND
R101, R103, R803	Resistor, 10 Ω	Digi-Key	P10ECT-ND
R102	Resistor, 5100 Ω	Digi-Key	P5.1KECT-ND
R801	Resistor, 100 Ω	Digi-Key	P10ECT-ND
R802	Resistor, 1000 Ω	Digi-Key	P1.0KECT-ND
R804	Resistor, 1300 Ω	Digi-Key	P1.3KGCT-ND
R805	Resistor, 1200 Ω	Digi-Key	P1.2KGCT-ND
S1	Transistor	Digi-Key	BCP5616TA-ND
S2	Potentiometer, 2k Ω	Digi-Key	3224W-202ECT-ND
S4	Voltage Regulator	Digi-Key	LM78L05ACM-ND
Output			
C201, C222	Capacitor, 10000 pF	Digi-Key	ATC200B103MW
C202, C211	Chip capacitor, 10 μ F	ATC	281M5002106k
C203	Chip capacitor, 4.7 pF	ATC	ATC100B4R7CT
C204	Chip capacitor, 56 pF	ATC	ATC100B560JT
C205, C206	Chip capacitor, 3.6 pF	ATC	ATC100B3R6CW
C207, C208	Chip capacitor, 1.3 pF	ATC	ATC100B1R3CW
C209, C210	Chip capacitor, 2.2 pF	ATC	ATC100B2R2CW
C212, C219	Chip capacitor, 1 μ F	ATC	478-3993-2-ND
C214, C217, C218, C237	Chip capacitor, 4.71 μ F	ATC	490-1864-2-ND
C215, C216, C220, C221	Capacitor, 10 μ F	Digi-Key	587-1818-2-ND

Package Outline Specifications

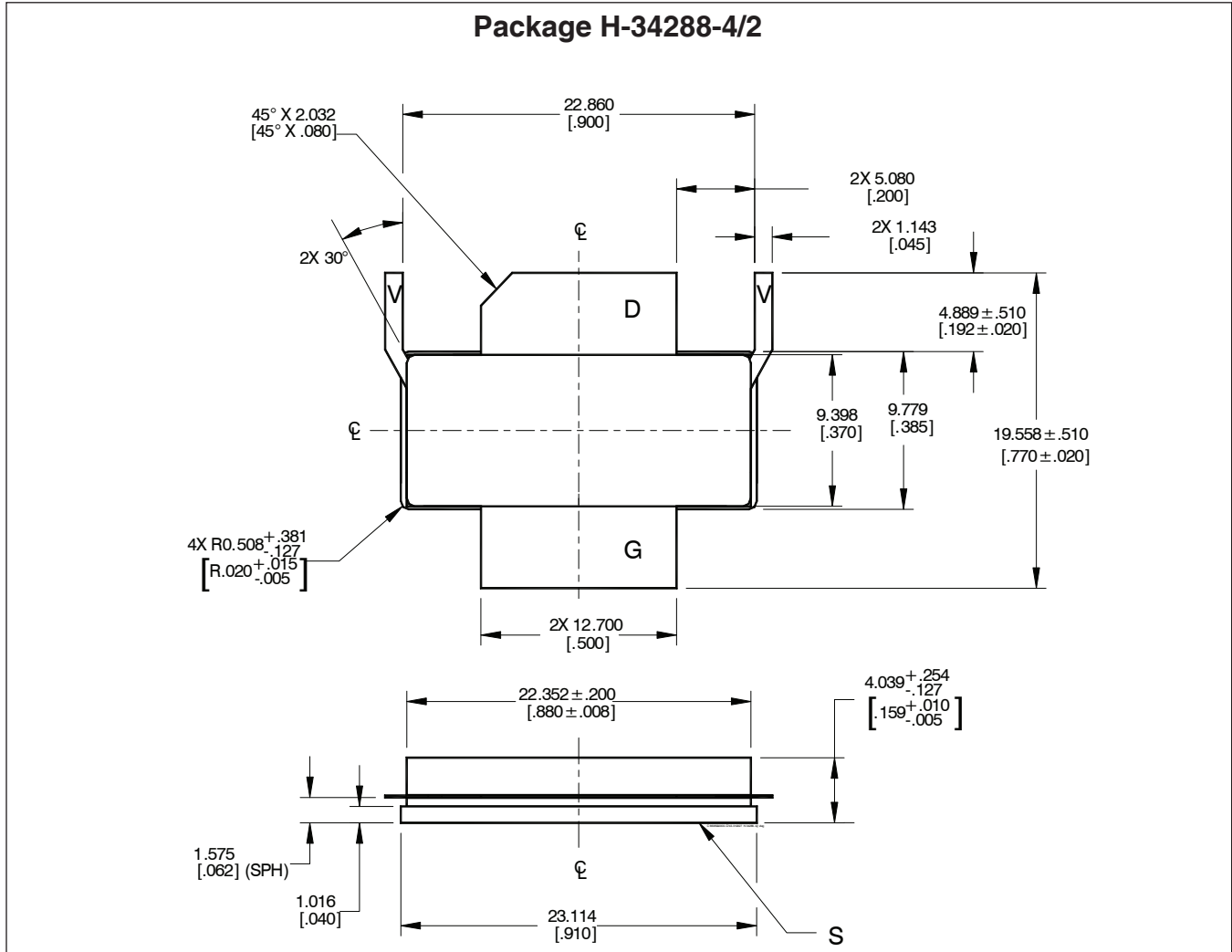

Diagram Notes—unless otherwise specified:

1. Interpret dimensions and tolerances per ASME Y14.5M-1994.
2. Primary dimensions are mm. Alternate dimensions are inches.
3. All tolerances ± 0.127 [mm] [.005] [inch] unless specified otherwise.
4. Pins: D = drain; S = source; G = gate; V = V_{DD}.
5. Lead thickness: 0.10 + 0.051/-0.025 mm [.004 +0.002/-0.001 inch].
6. Gold plating thickness: 0.25 micron [10 microinch] max.

Find the latest and most complete information about products and packaging at the Infineon Internet page <http://www.infineon.com/rfpower>