

Version :3.0

TECHNICAL SPECIFICATION
MODEL NO : PD050VL1

The content of this information is subject to be changed without notice.
Please contact PVI or its agent for further information.

Customer's Confirmation

Customer _____

Date _____

By _____

PVI's Confirmation

Confirmed By _____

Prepared By _____

Revision History

Rev.	Issued Date	Revised
1.0	May 7, 2007	New
2.0	Mar 12, 2008	Delete Page4 2. Features: Image Reversion : Up/Down and Left/Right
3.0	March.24.2008	Add Page 19 14.Handling Cautions 14-1 item e)

TECHNICAL SPECIFICATION**CONTENTS**

NO.	ITEM	PAGE
-	Cover	1
-	Revision History	2
-	Contents	3
1	Application	4
2	Features	4
3	Mechanical Specifications	4
4	Mechanical Drawing of TFT-LCD module	5
5	Input Terminals	7
6	Absolute Maximum Ratings	9
7	Electrical Characteristics	9
8	Pixel Arrangement	10
9	Display Color and Gray Scale Reference	11
10	Block Diagram	12
11	Interface Timing	13
12	Power On Sequence	16
13	Optical Characteristics	16
14	Handling Cautions	19
15	Reliability Test	21
16	Packing Diagram	22

1. Application

PD050VL1 module applies to computer peripheral, industrial meter, car TV, image communication and multi-media, which requires high quality flat panel display. If you must use in severe reliability environment, please don't extend over PVI's reliability test conditions.

2. Features.

- . Support the DENB mode, Sync mode (Hsync+Vsync)
- . Pixel in stripe configuration
- . Slim and compact
- . Amorphous silicon TFT LCD panel with LED B/L
- . LVDS transmission interface

3. Mechanical Specifications

Parameter	Specifications	Unit
Screen Size	5(diagonal)	inch
Display Format	640×(R,G,B)×480	dot
Display Colors	262K	
Active Area	101.76 (H)×74.88(V)	mm
Pixel Pitch	0.159(H)×0.156(V)	mm
Pixel Configuration	Stripe	
Outline Dimension	120.7(H)×92.8(V)×12.5(D) (Typ.)	mm
Back-light	24-LED	
Weight	173.6±10	g
Surface treatment	Anti-glare and SWV film	
Display mode	Normally white	
Gray scale inversion direction	6 (ref to Note 13-1)	o'clock

4. Mechanical Drawing of TFT-LCD Module
Outline Drawing : Front View (unit mm)

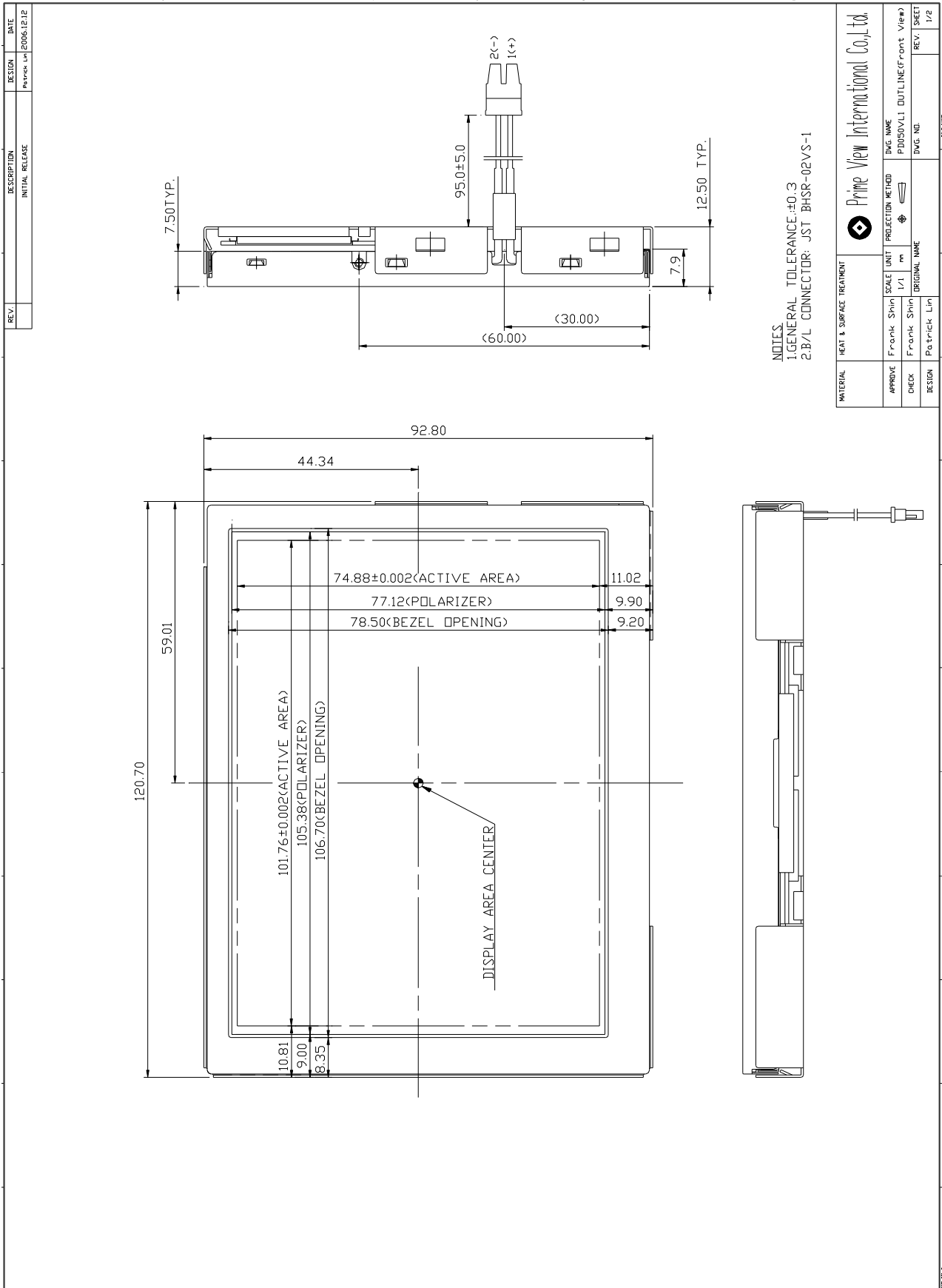

Outline Drawing : Rear View (unit mm)

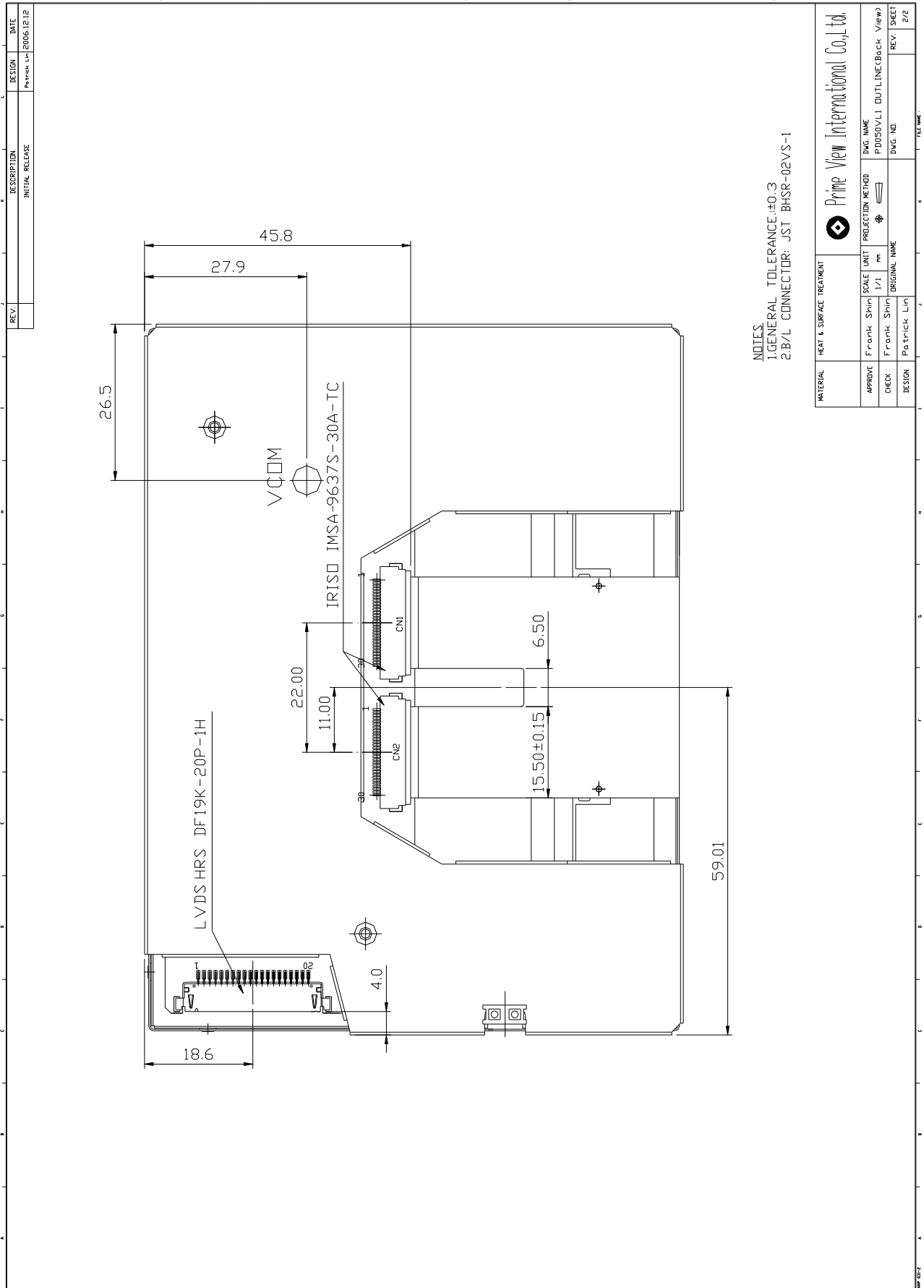

5. Input Terminals

5-1) TFT-LCD Panel Driving

Connector type: DFL19K-20P-1H(HRS)

Pin No.	Symbol	Function	Remark
1	Vcc	+3.3V Power Supply	
2	Vcc	+3.3V Power Supply	
3	GND	Ground	
4	GND	Ground	
5	INO-	LVDS receiver signal channel 0	
6	INO+	LVDS receiver signal channel 0	
7	GND	Ground	
8	IN1-	LVDS receiver signal channel 1	
9	IN1+	LVDS receiver signal channel 1	
10	GND	Ground	
11	IN2-	LVDS receiver signal channel 2	
12	IN2+	LVDS receiver signal channel 2	
13	GND	Ground	
14	CLK-	LVDS receiver signal clock	
15	CLK+	LVDS receiver signal clock	
16	GND	Ground	
17	NC	No connection	
18	NC	No connection	
19	GND	Ground	
20	GND	Ground	

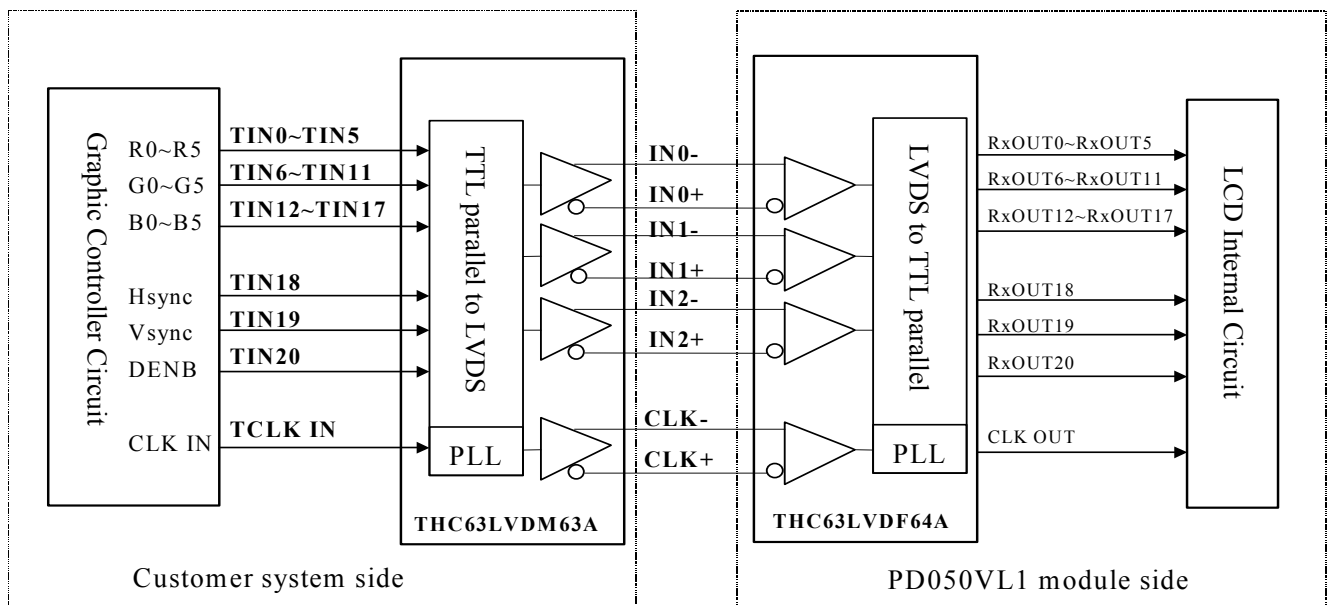
LVDS Interface Block Diagram

Recommended Transmitter (THC63LVDM63A Thane) to PD050VL1 interface Assignment:

Input terminal of THC63LVDM63A		Graphic controller output signal		Output signal symbol	To PD050VL1 interface terminal (Symbol)
Symbol	No.	Symbol	Function		
TIN0	44	R0	Red pixel data (LSB)	} Tout0- } Tout0+	No.5 : IN0- No.6 : IN0+
TIN1	45	R1	Red pixel data		
TIN2	47	R2	Red pixel data		
TIN3	48	R3	Red pixel data		
TIN4	1	R4	Red pixel data		
TIN5	3	R5	Red pixel data(MSB)		
TIN6	4	G0	Green pixel data (LSB)	} Tout1- } Tout1+	No.8 : IN1- No.9 : IN1+
TIN7	6	G1	Green pixel data		
TIN8	7	G2	Green pixel data		
TIN9	9	G3	Green pixel data		
TIN10	10	G4	Green pixel data		
TIN11	12	G5	Green pixel data(MSB)		
TIN12	13	B0	Blue pixel data(LSB)	} Tout2- } Tout2+	No.11 : IN2- No.12 : IN2+
TIN13	15	B1	Blue pixel data		
TIN14	16	B2	Blue pixel data		
TIN15	18	B3	Blue pixel data		
TIN16	19	B4	Blue pixel data		
TIN17	20	B5	Blue pixel data(MSB)		
TIN18	22	Hsync	Horizontal Synchronous Signal	} Tout2+	No.12 : IN2+
TIN19	23	Vsync	Vertical Synchronous Signal		
TIN20	25	DENB	Compound Synchronization signal		
CLK in	26	CLK	Data sampling clock	TCLK out- TCLK out+	No.14 : CLK- No.15 : CLK+

DENB input signal.

If customer wanted to off the DENB mode , you must keep the DENB always High or Low.

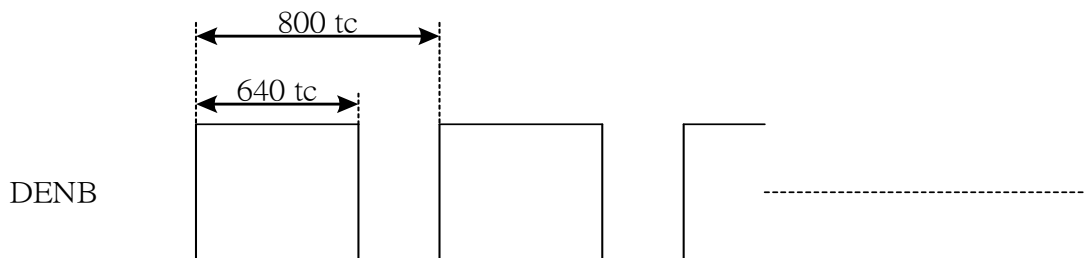

(tc: the period of sampling clock)

5-2) Backlight driving

Connector type: JST BHSR-02VS-1, PIN No 2 pin

Pin No	Symbol	Description	Remark
1	+	Input terminal (Positive electrode side)	Wire color : Red
2	-	Input terminal (Ground side)	Wire Color : Black

6. Absolute Maximum Ratings :

The followings are maximum values, which if exceeded, may cause faulty operation or damage to the unit.

GND=0V, Ta=25°C

Parameters	Symbol	MIN.	MAX.	Unit	Remark
Supply Voltage	V _{CC}	-0.3	+7.0	V	
Input Signals Voltage	V _{sig}	-0.3	V _{CC} +0.3	V	Note 6-1

Note 6-1 : Input signals include CLK , Hsync , Vsync , DENB , R[0:5] , G[0:5] and B[0:5].

7. Electrical Characteristics

7-1) Recommended Operating Conditions:

GND = 0V , Ta = 25°C

Item	Symbol	Min.	Typ.	Max.	Unit	Remark
Supply Voltage	V _{CC}	3.0	3.3	3.6	V	
Current Dissipation	I _{CC}	-	77.90	-	mA	Note 7-1
LVDS Differential input high threshold	V _{TH}	-	-	100	mV	Note7-2
LVDS Differential input low threshold	V _{TL}	-100	-	-		
V _{com} Voltage	V _{com}	-	2.7	-	V	

Note 7-1 : To test the current dissipation of VCC using the “color bars” testing pattern shown as below

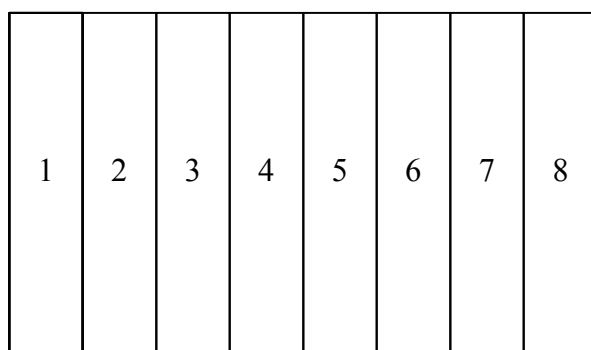

1. White
2. Yellow
3. Cyan
4. Green
5. Magenta
6. Red
7. Blue
8. Black

I_{DD} current dissipation testing pattern

Note7-2 : Please refers to THC63LVDF64A specification by THINE Corporation.
This LCD module conforms to LVDS standard.

7-2) Recommended driving condition for LED backlight

GND = 0V , Ta = 25°C

Parameter	Symbol	Min	TYP	MAX	Unit	Remark
Supply voltage of LED backlight	V_{LED}	-	11.0	11.5	V	$I_L = 20\text{ mA}$
Supply current of LED backlight	I_{LED}	-	20	-	mA	Note 7-3
Backlight Power Consumption	P_{LED}	-	1.76	1.84	W	Note 7-4

Note 7-3: The LED driving condition is defined for each LED module. (3 LED Serial)

Note 7-4: $P_{LED} = V_{LED1} * I_{LED1} + V_{LED2} * I_{LED2} + \dots + V_{LED7} * I_{LED7} + V_{LED8} * I_{LED8}$

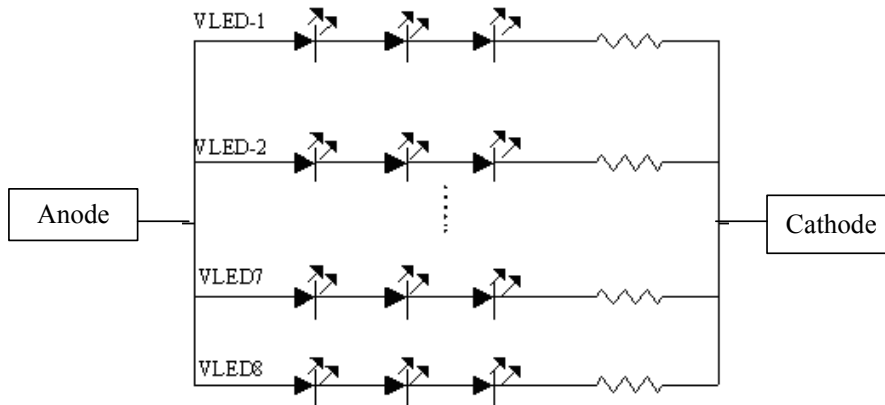

8. Pixel Arrangement

The LCD module pixel arrangement is the stripe.

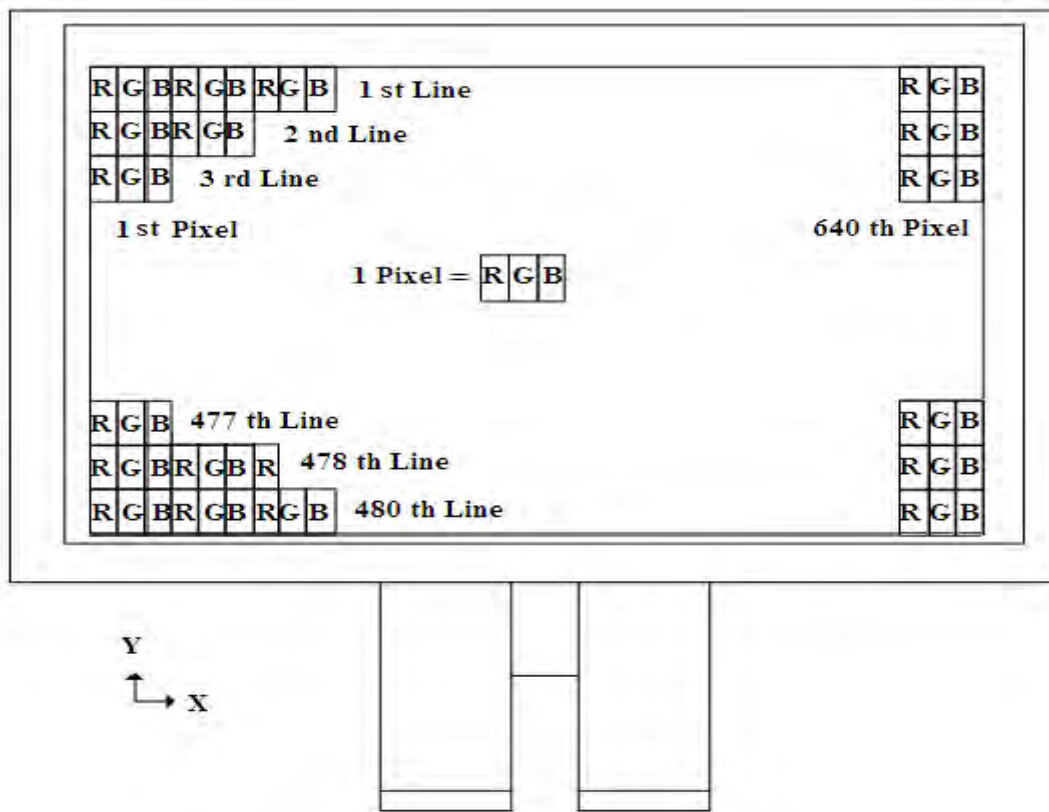

9. Display Color and Gray Scale Reference

Color		Input Color Data																	
		Red						Green						Blue					
		R5	R4	R3	R2	R1	R0	G5	G4	G3	G2	G1	G0	B5	B4	B3	B2	B1	B0
Basic Colors	Black	0	0	0	0	0	0	0	0	0	0	0	0	0	0	0	0	0	0
	Red (63)	1	1	1	1	1	1	0	0	0	0	0	0	0	0	0	0	0	0
	Green (63)	0	0	0	0	0	0	1	1	1	1	1	1	0	0	0	0	0	0
	Blue (63)	0	0	0	0	0	0	0	0	0	0	0	0	1	1	1	1	1	1
	Cyan	0	0	0	0	0	0	1	1	1	1	1	1	1	1	1	1	1	1
	Magenta	1	1	1	1	1	1	0	0	0	0	0	0	1	1	1	1	1	1
	Yellow	1	1	1	1	1	1	1	1	1	1	1	1	0	0	0	0	0	0
	White	1	1	1	1	1	1	1	1	1	1	1	1	1	1	1	1	1	1
Red	Red (00)	0	0	0	0	0	0	0	0	0	0	0	0	0	0	0	0	0	0
	Red (01)	0	0	0	0	0	1	0	0	0	0	0	0	0	0	0	0	0	0
	Red (02)	0	0	0	0	1	0	0	0	0	0	0	0	0	0	0	0	0	0
	Darker																		
	↓	↓	↓	↓	↓	↓	↓	↓	↓	↓	↓	↓	↓	↓	↓	↓	↓	↓	↓
	Brighter																		
	Red (61)	1	1	1	1	0	1	0	0	0	0	0	0	0	0	0	0	0	0
	Red (62)	1	1	1	1	1	0	0	0	0	0	0	0	0	0	0	0	0	0
Red (63)	1	1	1	1	1	1	0	0	0	0	0	0	0	0	0	0	0	0	
Green	Green (00)	0	0	0	0	0	0	0	0	0	0	0	0	0	0	0	0	0	0
	Green (01)	0	0	0	0	0	0	0	0	0	0	0	1	0	0	0	0	0	0
	Green (02)	0	0	0	0	0	0	0	0	0	0	1	0	0	0	0	0	0	0
	Darker																		
	↓	↓	↓	↓	↓	↓	↓	↓	↓	↓	↓	↓	↓	↓	↓	↓	↓	↓	↓
	Brighter																		
	Green (61)	0	0	0	0	0	0	1	1	1	1	0	1	0	0	0	0	0	0
	Green (62)	0	0	0	0	0	0	1	1	1	1	1	0	0	0	0	0	0	0
Green (63)	0	0	0	0	0	0	1	1	1	1	1	1	0	0	0	0	0	0	
Blue	Blue (00)	0	0	0	0	0	0	0	0	0	0	0	0	0	0	0	0	0	0
	Blue (01)	0	0	0	0	0	0	0	0	0	0	0	0	0	0	0	0	0	1
	Blue (02)	0	0	0	0	0	0	0	0	0	0	0	0	0	0	0	0	1	0
	Darker																		
	↓	↓	↓	↓	↓	↓	↓	↓	↓	↓	↓	↓	↓	↓	↓	↓	↓	↓	↓
	Brighter																		
	Blue (61)	0	0	0	0	0	0	0	0	0	0	0	0	1	1	1	1	0	1
	Blue (62)	0	0	0	0	0	0	0	0	0	0	0	0	1	1	1	1	1	0
Blue (63)	0	0	0	0	0	0	0	0	0	0	0	0	1	1	1	1	1	1	

10. Block Diagram

10-1) TFT-module Block Diagram

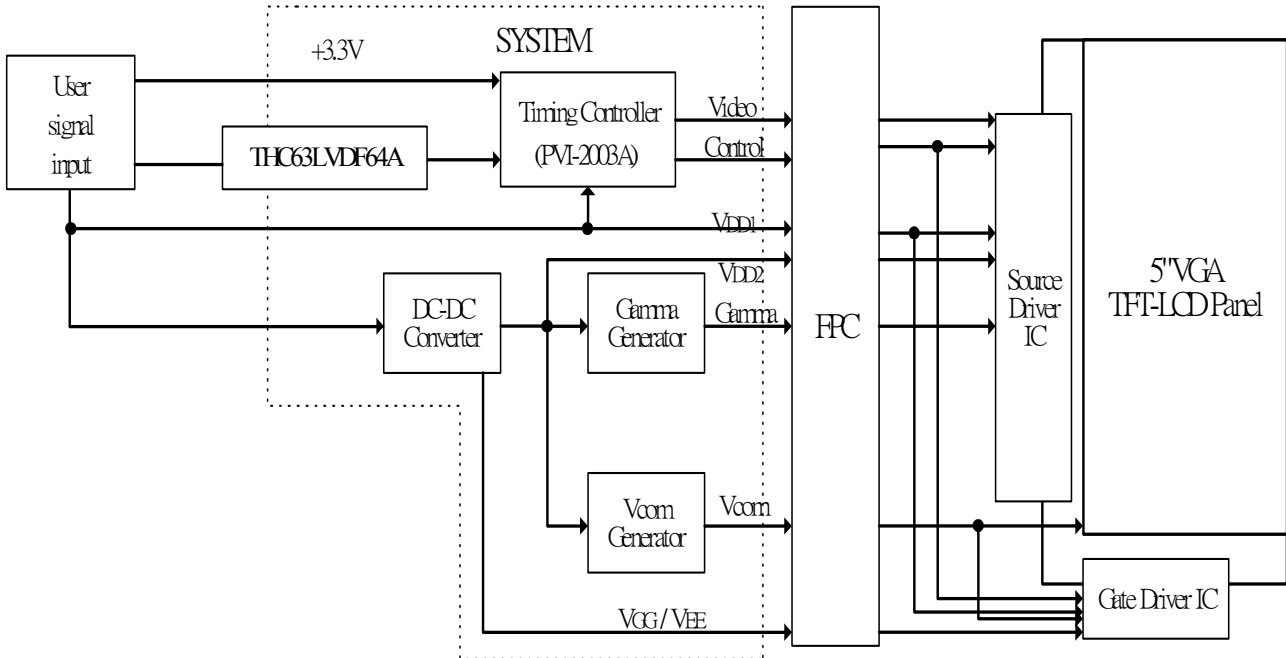

11. Interface Timing
 11-1) Timing Parameters

		Symbol	Min.	Typ.	Max.	Unit	
Power supply		VCC	3.0	3.3	3.6	V	
CLK	Frequency	1/tc	-	25	-	MHz	
		tc	-	40	-	ns	
HSYNC	Period	Hp	-	32	-	us	
			-	800	-	tc	
	Display period	Hdp	-	640	-	tc	
	Pulse width	Hpw	-	96	-	tc	
	Back-porch	Hbp	-	46	-	tc	
	Front-porch	Hfp	-	18	-	tc	
	Hpw+Hbp			-	142	-	tc
	Hsync-CLK	Hhc	10	-	Tc-10	ns	
Vsync-Hsync	Hvh	0	0	200	tc		
VSYNC	Period	Vp	-	16.8	-	ms	
			-	525	-	Hp	
	Display period	Vdp	-	480	-	Hp	
	Pulse width	Vpw	-	2	-	Hp	
	Back-porch	Vbp	-	33	-	Hp	
	Front-porch	Vfp	-	10	-	Hp	
	Vpw+Vbp			-	35	-	Hp
DENB	Horizontal scanning period	T1	-	800	-	tc	
	Horizontal display period	T2	-	640	-	tc	
	Vertical display period	T3	-	480	-	T1	
	Frame cycling period	T4	520	525	800	T1	
R,G,B	CLK-DATA	Dcd	10	-	-	ns	
	DATA-CLK	Ddc	8	-	-	ns	

11-2) The Timing Diagram
 a.1 Input signal range

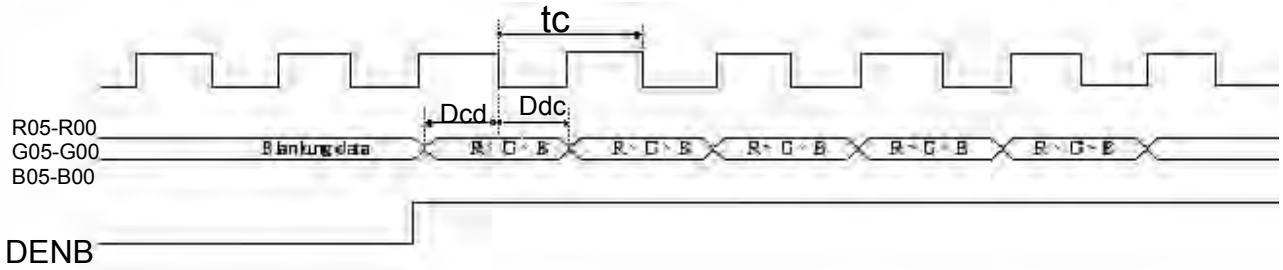

a.2 HSYNC timing

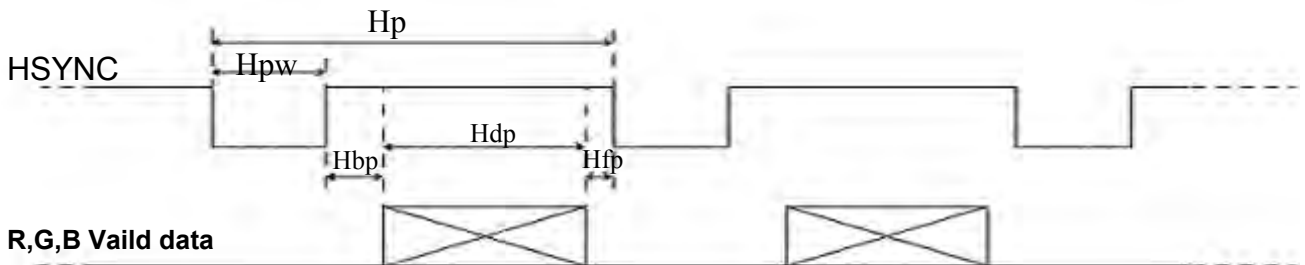

a.3 CLK, HSYNC relationship



a.4 HSYNC, VSYNC relationship

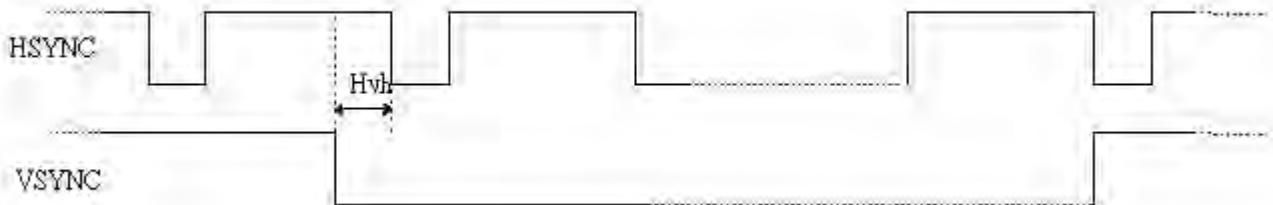

a.5 VSYNC timing

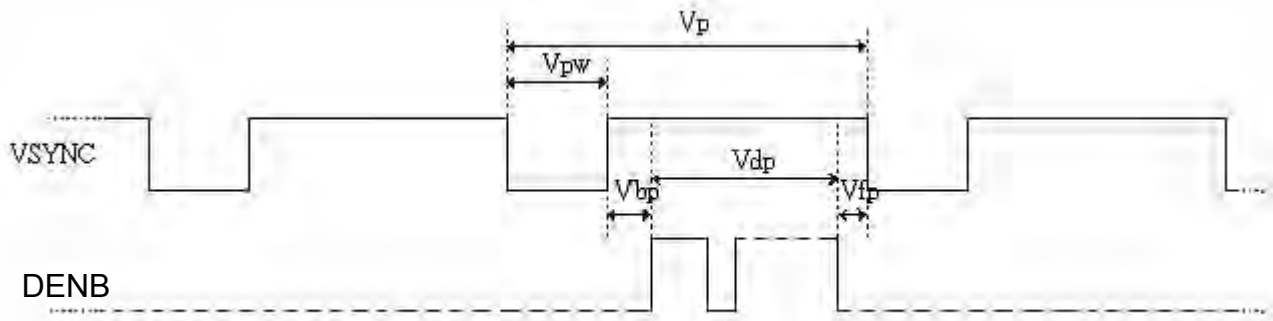

a.6 DENB timing

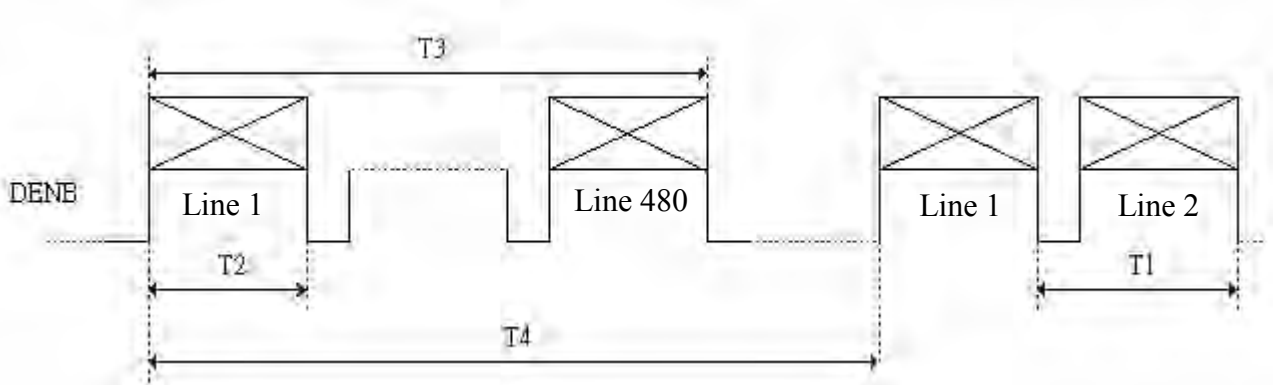

12. Power On Sequence

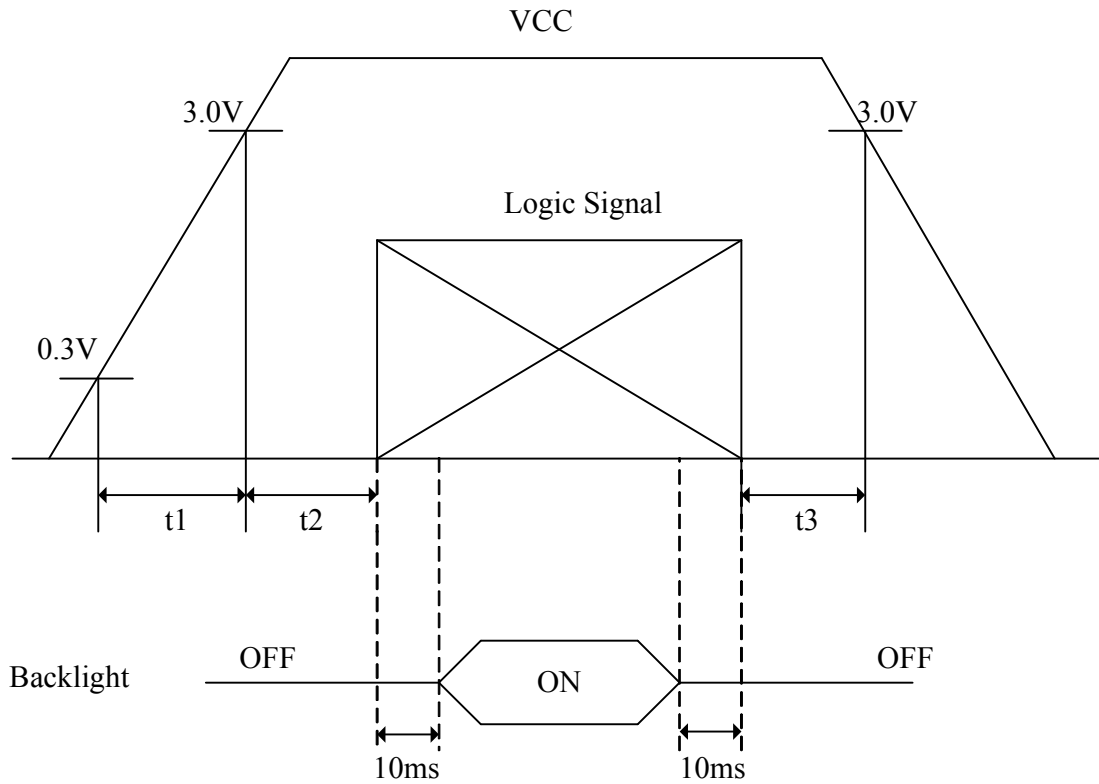

1. $0 < t_1 \leq 20\text{ms}$
2. $0 < t_2 \leq 50\text{ms}$
3. $0 < t_3 \leq 1\text{s}$

13. Optical Characteristics

13-1) Specification:

$T_a = 25^\circ\text{C}$

Parameter		Symbol	Condition	MIN.	TYP.	MAX.	Unit	Remarks
Viewing Angle	Horizontal	$\theta 21, \theta 22$	CR > 10	55	60	-	deg	Note 13-1
	Vertical	$\theta 12$		35	40	-	deg	
		$\theta 11$		50	55	-	deg	
Contrast Ratio		CR	At optimized Viewing angle	200	400	-	-	Note 13-2
Response time	Rise	Tr	$\theta = 0^\circ$	-	15	30	ms	Note 13-4
	Fall	Tf		-	25	50	ms	
Brightness		L	$\theta = 0^\circ$	400	450	-	cd/m ²	Note 13-3
Uniformity		U		70	80	-	%	Note 13-6
Cross Talk		-	$\theta = 0^\circ$	-	-	3.5	%	Note 13-7
White Chromaticity		x	$\theta = 0^\circ$	0.28	0.31	0.34	-	Note 13-3
		y		0.31	0.34	0.37	-	
LED Life Time			+25 $^\circ\text{C}$	20,000	30,000	-	hrs	Note 13-5

Note 13-1 : The definitions of viewing angle diagrams :

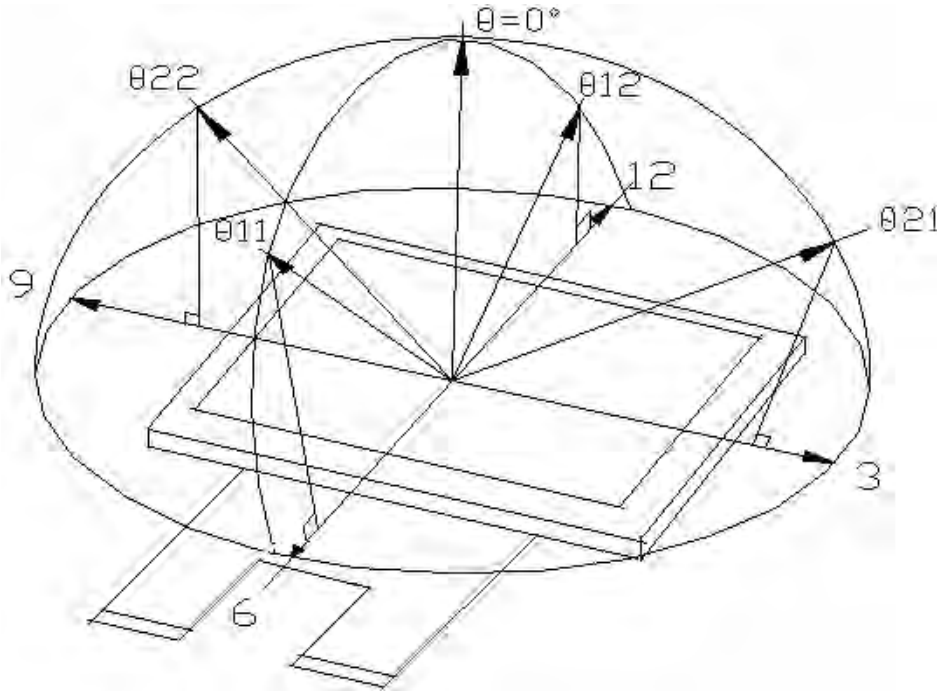

Note 13-2: $CR = \frac{\text{Luminance when LCD is White}}{\text{Luminance when LCD is Black}}$
 Contrast Ratio is measured in optimum common electrode voltage.

Note 13-3 : Topcon BM-7 (fast) luminance meter 1° field of view is used in the testing (after 20~30 minutes operation).

Note 13-4 : The definitions of response time T_r and T_f :

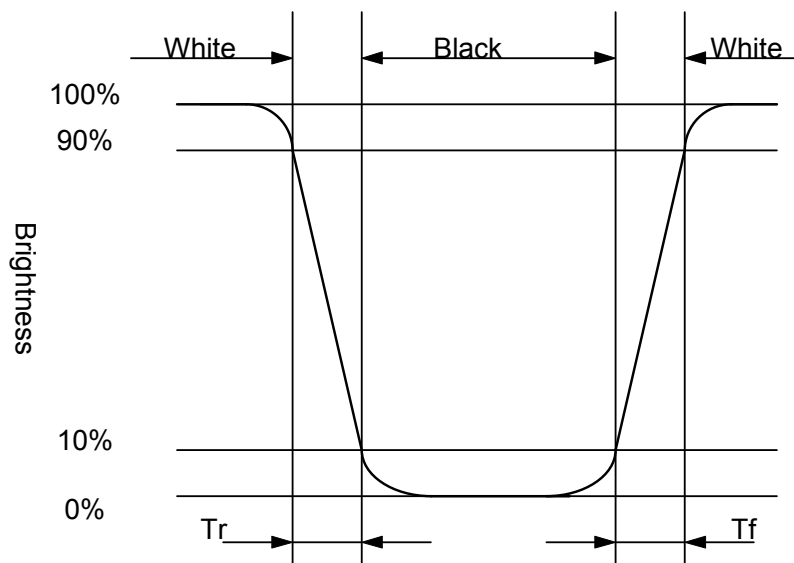

Note 13-5: The “LED Life time “ is defined as the module brightness decrease to 50% original Brightness that the ambient temperature is 25°C and $I_{LED} = 160\text{mA}$.

Note 13-6 : The uniformity of LCD is defined as

$$U = \frac{\text{The Minimum Brightness of the 9 testing Points}}{\text{The Maximum Brightness of the 9 testing Points}}$$

- Luminance meter : BM-5A or BM-7 fast (TOPCON)
- Measurement distance : 500 mm +/- 50 mm
- Ambient illumination : < 1 Lux
- Measuring direction : Perpendicular to the surface of module
- The test pattern is white (Gray Level 63).

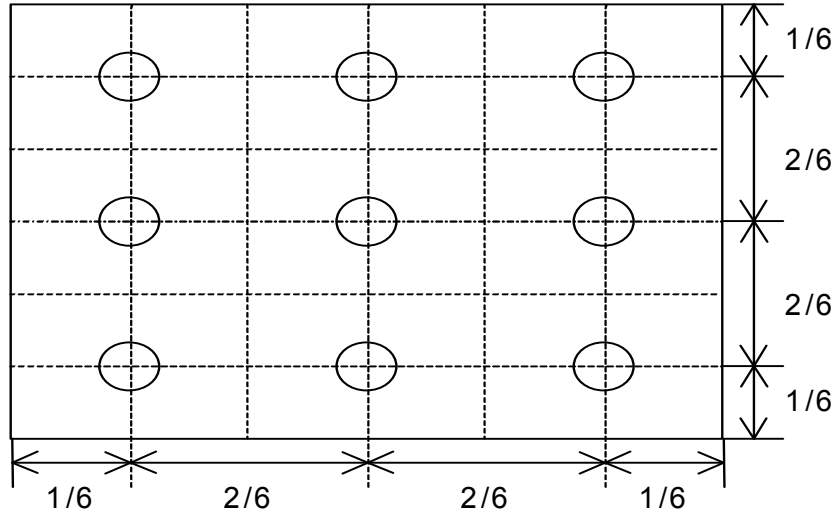

Note 13-7: Cross Talk (CTK) = $\frac{|YA-YB|}{YA} \times 100\%$

- YA: Brightness of Pattern A
- YB: Brightness of Pattern B
- Luminance meter : BM 5A or BM-7 fast (TOPCON)
- Measurement distance : 500 mm +/- 50 mm
- Ambient illumination : < 1 Lux
- Measuring direction : Perpendicular to the surface of module

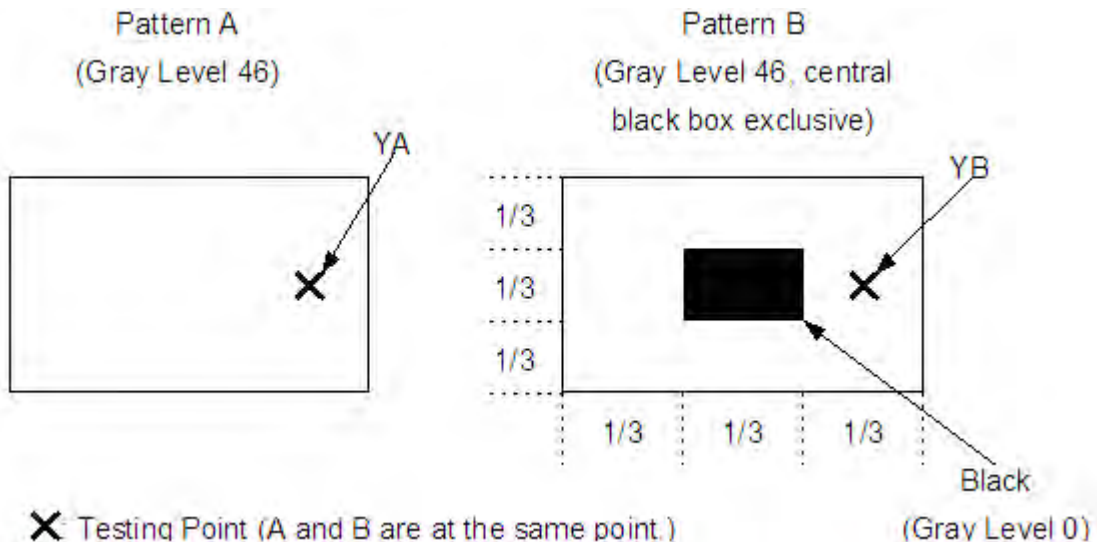

14. Handling Cautions

14-1) Mounting of module

- a) Please power off the module when you connect the input/output connector.
- b) Please connect the ground pattern of the inverter circuit surely. If the connection is not perfect, some following problems may happen possibly.
 - 1.The noise from the backlight unit will increase.
 - 2.The output from inverter circuit will be unstable.
 - 3.In some cases a part of module will heat.
- c) Polarizer which is made of soft material and susceptible to flaw must be handled carefully.
- d) Protective film (Laminator) is applied on surface to protect it against scratches and dirt.
- e) Please following the tear off direction as figure14-1 to remove the protective film as slowly as possible, so that electrostatic charge can be minimized.

14-2) Precautions in mounting

- a) When metal part of the TFT-LCD module (shielding lid and rear case) is soiled, wipe it with soft dry cloth.
- b) Wipe off water drops or finger grease immediately. Long contact with water may cause discoloration or spots.
- c) TFT-LCD module uses glass, which breaks or cracks easily if dropped or bumped on hard surface. Please handle with care.
- d) Since CMOS LSI is used in the module. So take care of static electricity and earth yourself when handling.

14-3) Adjusting module

- a) Adjusting volumes on the rear face of the module have been set optimally before shipment.
- b) Therefore, do not change any adjusted values. If adjusted values are changed, the specifications described may not be satisfied.

14-4) Others

- a) Do not expose the module to direct sunlight or intensive ultraviolet rays for many hours.
- b) Store the module at a room temperature place.
- c) The voltage of beginning electric discharge may over the normal voltage because of leakage current from approach conductor by to draw lump read lead line around.
- d) If LCD panel breaks, it is possibly that the liquid crystal escapes from the panel. Avoid putting it into eyes or mouth. When liquid crystal sticks on hands, clothes or feet. Wash it out immediately with soap.
- e) Observe all other precautionary requirements in handling general electronic components.
- f) Please adjust the voltage of common electrode as material of attachment by 1 module.

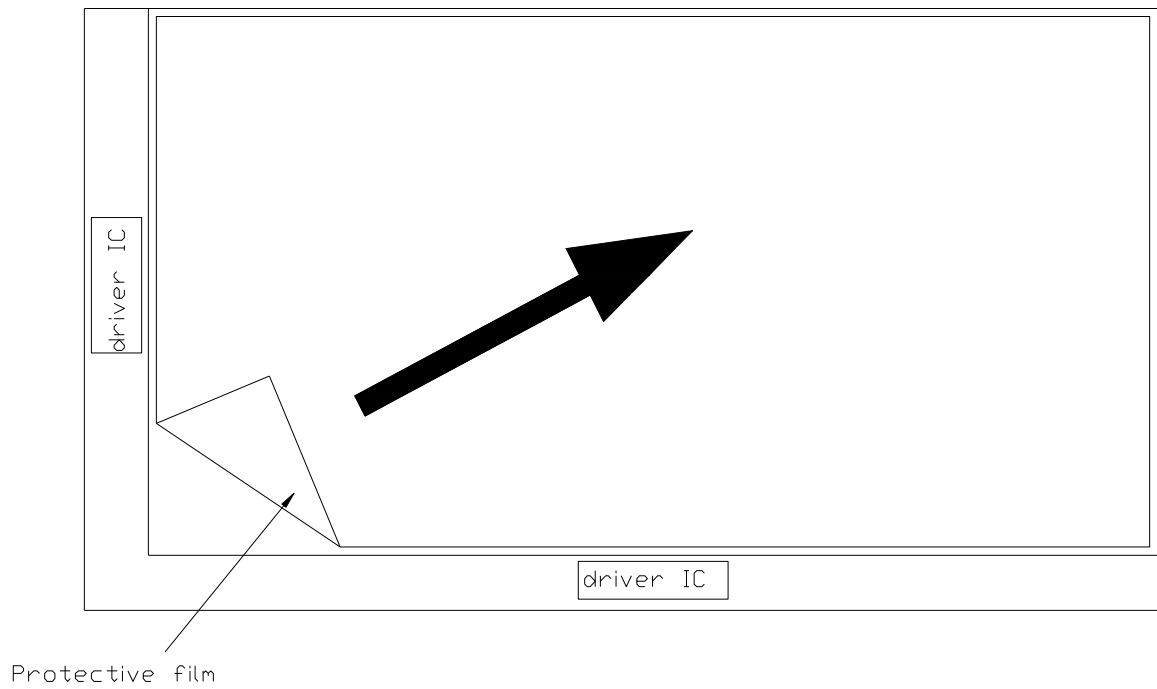

Figure 14-1 the way to peel off protective film

15. Reliability Test

No	Test Item	Test Condition
1	High Temperature Storage Test	Ta = +90°C, 240 hrs
2	Low Temperature Storage Test	Ta = -40°C, 240 hrs
3	High Temperature Operation Test	Ta = +80°C, 240 hrs
4	Low Temperature Operation Test	Ta = -30°C, 240 hrs
5	High Temperature & High Humidity Operation Test	Ta = +60°C, 90%RH, 240 hrs
6	Thermal Cycling Test (non-operating)	-30°C → +80°C, 200 Cycles 30 min 30 min
7	Vibration Test (non-operating)	Frequency : 10 ~ 55 Hz Amplitude : 1 mm Sweep time: 11 mins Test Period: 6 Cycles for each direction of X, Y, Z
8	Shock Test (non-operating)	100G, 6ms Direction: ±X, ±Y, ±Z Cycle: 3 times
9	Electrostatic Discharge Test (non-operating)	150pF, 330Ω Air : ±15KV ; Contact : ±8KV 10 times/point , 9 points/panel face

Ta: ambient temperature

[Criteria]

In the standard conditions, there is not display function NG issue occurred. (including: line defect ,no image).All the cosmetic specification is judged before the reliability stress.

16. Packing Diagram

