

RoHS Compliant Product

A suffix of "-C" specifies halogen & lead-free

**FEATURES**

- Fast Switching Speed
- For General Purpose Switching Application
- Surface Mount Package Ideally Suited for Automatic Insertion

**MECHANICAL DATA**

- Case: SOD-323L, Molded Plastic
- Polarity: See Diagrams Below
- Mounting Position : Any
- Shipping : 3000 / Tape & Reel

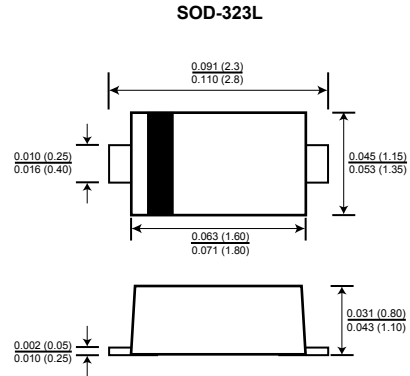

**MAXIMUM RATINGS**

Rating	Symbol	Value	Unit
Reverse Voltage	$V_R$	100	Vdc
Forward Current	$I_F$	200	mAdc
Peak Forward Surge Current	$I_{FM}(\text{surge})$	500	mAdc

**THERMAL CHARACTERISTICS**

Characteristic	Symbol	Max	Unit
Total Device Dissipation FR-5 Board,* $T_A = 25^\circ\text{C}$ Derate above $25^\circ\text{C}$	$P_D$	200 1.57	mW mW/ $^\circ\text{C}$
Thermal Resistance Junction to Ambient	$R_{\theta JA}$	635	$^\circ\text{C}/\text{W}$
Junction and Storage Temperature	$T_J, T_{stg}$	-50 to +150	$^\circ\text{C}$

\*FR-4 Minimum Pad

**DEVICE MARKING**

MMDL914 = 5D

**ELECTRICAL CHARACTERISTICS** ( $T_A = 25^\circ\text{C}$  unless otherwise noted)

Characteristic	Symbol	Min	Max	Unit
----------------	--------	-----	-----	------

**OFF CHARACTERISTICS**

Reverse Breakdown Voltage ( $I_R = 100 \mu\text{Adc}$ )	$V_{(BR)}$	100	—	Vdc
Reverse Voltage Leakage Current ( $V_R = 20 \text{Vdc}$ ) ( $V_R = 75 \text{Vdc}$ )	$I_R$	— —	25 5.0	nAdc $\mu\text{Adc}$
Diode Capacitance ( $V_R = 0, f = 1.0 \text{MHz}$ )	$C_T$	—	4.0	pF
Forward Voltage ( $I_F = 10 \text{mAdc}$ )	$V_F$	—	1.0	Vdc
Reverse Recovery Time ( $I_F = I_R = 10 \text{mAdc}$ ) (Figure 1)	$t_{rr}$	—	4.0	ns

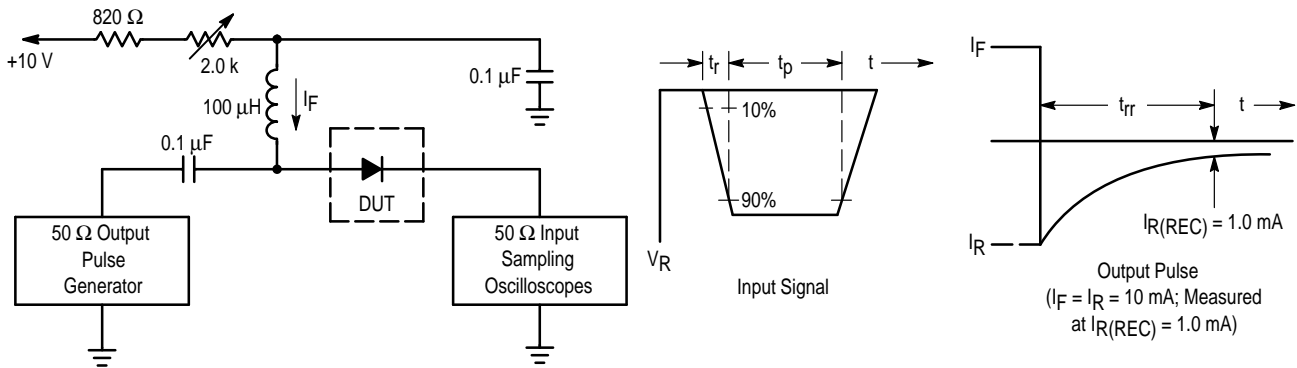

- Notes: 1. A 2.0 kΩ variable resistor adjusted for a Forward Current ( $I_F$ ) of 10 mA.  
 2. Input pulse is adjusted so  $I_{R(\text{peak})}$  is equal to 10 mA.  
 3.  $t_p \gg t_{rr}$

**Figure 1. Recovery Time Equivalent Test Circuit**

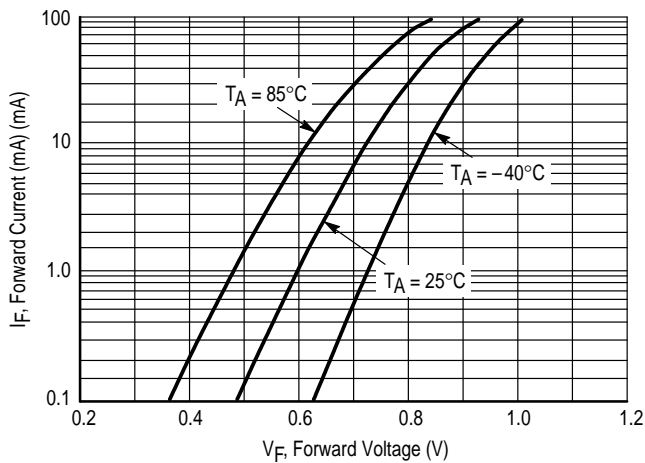

**Figure 2. Forward Voltage**

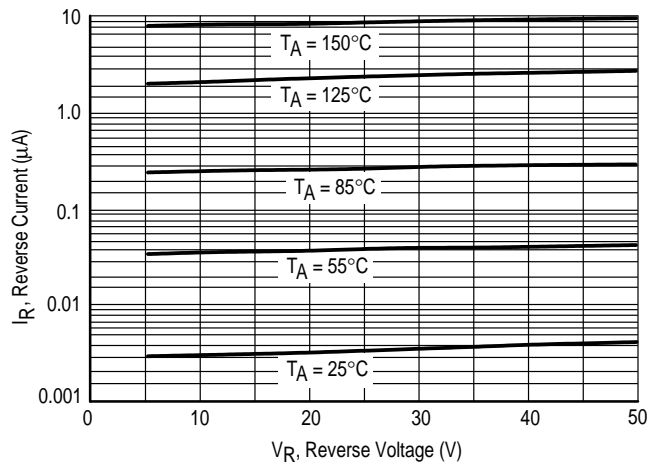

**Figure 3. Leakage Current**

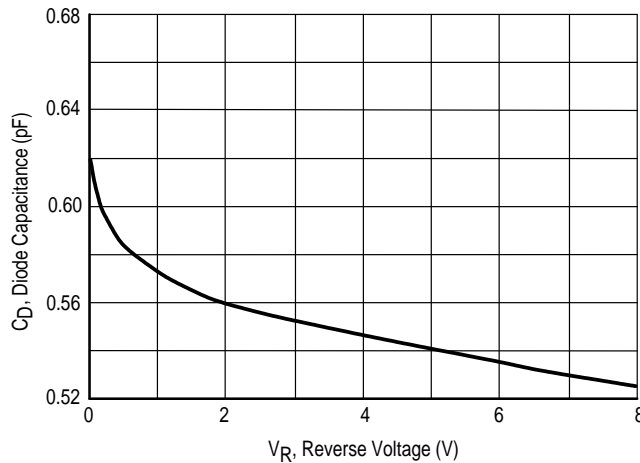

**Figure 4. Capacitance**