



Obsolescence Notice

This product is obsolete.

This information is available for your convenience only.

For more information on Zarlink's obsolete products and replacement product lists, please visit http://products.zarlink.com/obsolete_products/

***THIS DOCUMENT IS FOR MAINTENANCE
PURPOSES ONLY AND IS NOT
RECOMMENDED FOR NEW DESIGNS***

SP8790

60MHz ÷ 4 (2-MODULUS EXTENDER)

The SP8790 is a divide-by-four counter designed for use with 2-modulus dividers. It increases the minimum division ratio of the 2-modulus divider while retaining the same difference in division ratio. The device is suitable for use in low power frequency synthesis interfacing to CMOS or TTL.

FEATURES

- Very Low Power
- Control Input and Counter Output will Interface Directly to TTL or CMOS
- Interfaces to GPS SP8000 Series Programmable 2-Modulus Dividers

QUICK REFERENCE DATA

- Supply Voltage: 5.0V
- Power Consumption: 40mW
- Temperature Range: -55°C to +125°C (A Grade)
-30°C to +70°C (B Grade)

ABSOLUTE MAXIMUM RATINGS

Supply voltage	8V
Open collector output voltage	12V
Storage temperature range	-65°C to +150°C
Max. junction temperature	+175°C
Max. clock input voltage	2.5V p-p
Output sink current	10mA

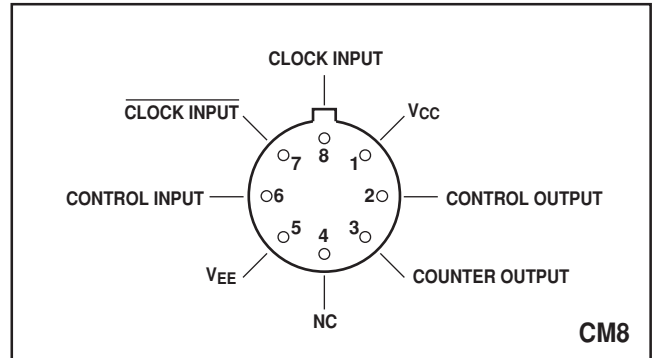

Fig. 1 Pin connections - bottom view

ORDERING INFORMATION

- SP8790 A CM
- SP8790 B CM

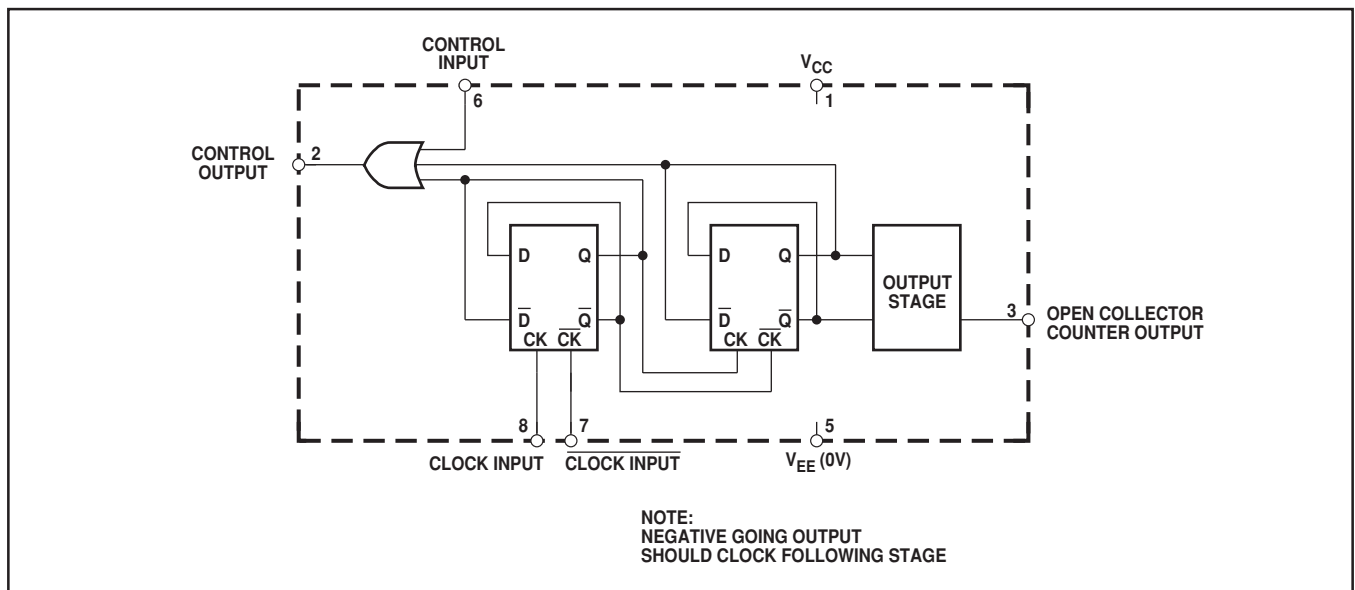

Fig. 2 Functional diagram

ELECTRICAL CHARACTERISTICS

Unless otherwise stated, the Electrical Characteristics are guaranteed over specified supply, frequency and temperature range

Supply voltage, $V_{CC} = 5V \pm 0.25V$, $V_{EE} = 0V$

Temperature, $T_{AMB} = -55^{\circ}C$ to $+125^{\circ}C$ (A Grade), $-30^{\circ}C$ to $+70^{\circ}C$ (B Grade)

Characteristic	Symbol	Value		Units	Conditions	Notes	
		Min.	Max.				
Maximum frequency (sinewave input)	f_{MAX}	60		MHz	Tested as a controller, see Fig. 4	2	
Power supply current	I_{CC}		11	mA		2	
Control input high voltage	V_{INH}	3.5	10	V		2	
Control input low voltage	V_{INL}	0	1.5	V		2	
Output high voltage (pin 3)	V_{OH}	9		V		Pin 3 via 1.6kΩ to +10V	2
Output low voltage (pins 3)	V_{OL}		0.4	V		Pin 3 via 1.6kΩ to +10V	2
Output high voltage (pin 2)	V_{OH}	4.27	4.5	V		$V_{CC} = 5.2V$ (25°C)	
Output low voltage (pin 2)	V_{OL}	3.28	3.7	V		$V_{CC} = 5.2V$ (25°C)	
Clock to counter output –ve going delay	t_{pHL}		25	ns			3
Clock to counter output +ve going delay	t_{pLH}		40	ns			3
Clock to control output –ve going delay	t_{pHL}		15	ns		10kΩ pull-down on control output	3, 4
Clock to control output +ve going delay	t_{pLH}		26	ns		10kΩ pull-down on control output	3, 4
Control input to control output –ve going delay	t_{pHL}		12	ns		10kΩ pull-down on control output	3, 4
Control input to control output +ve going delay	t_{pLH}		16	ns		10kΩ pull-down on control output	3, 4

NOTES

1. The test configuration for dynamic testing is shown in Fig.4.
2. Tested at low and high temperatures only.
3. Guaranteed but not tested.
4. The propagation delays stated are with the device controlling the SP8695, which has internal 10kΩ pull-down resistors on its PE inputs. These propagation delays will be reduced when the device is used with the SP8643/47 and SP8740 series of 2-modulus dividers, which have internal 4.3kΩ pull-downs. Refer to relevant data sheet/s.

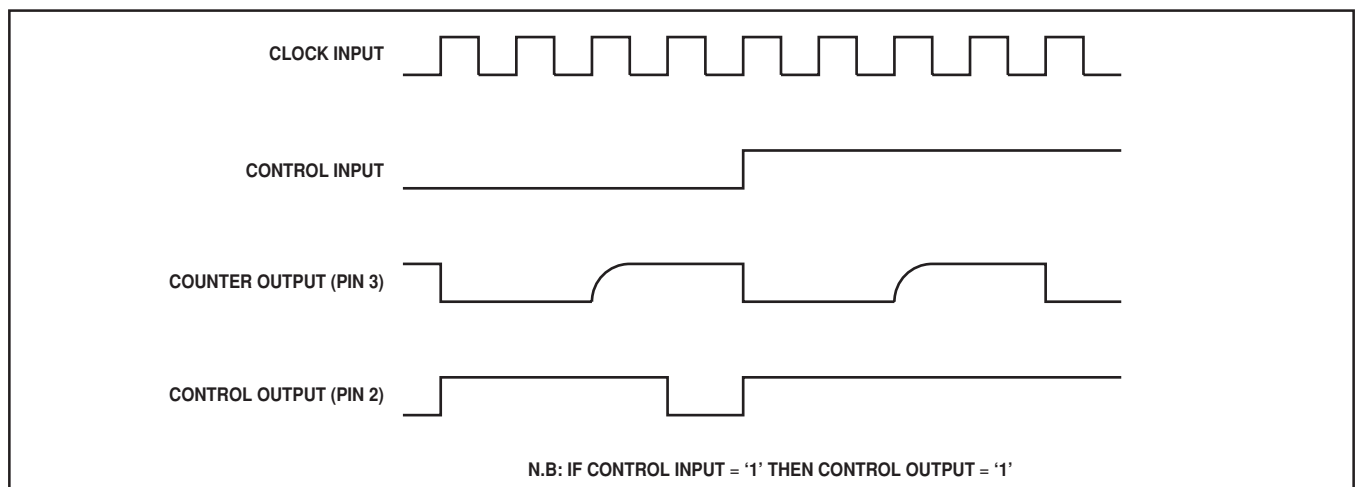

Fig. 3 Timing diagram

OPERATING NOTES

1. The device will normally be driven by capacitively coupling the inputs to the outputs of a 2-modulus divider, as shown in Figs. 4 and 5. The maximum frequency of the device when used as a controller is limited by the internal delays to 60MHz. However, when used as a ÷4 prescaler, it will operate at frequencies in excess of 80MHz, the maximum frequency being limited by saturation of the output stage.
2. The device is normally driven from very fast edges of a 2-modulus divider, in which case there is no input slew rate problem.
3. The control input is TTL/CMOS compatible.

4. The counter output (pin 3) interfaces to TTL/CMOS by the addition of a pull-up resistor. For interfacing to CMOS, the output can be connected with a pull-up resistor to a supply which must not exceed 12V.
5. When used as a controller the device will self-oscillate in the absence of an input signal; this can be prevented by connecting a 47kΩ resistor from pin 7 to ground, as shown in Fig. 5.
6. The control output, which includes an internal 16kΩ pull-down resistor, is ECL compatible and will interface directly to ECL 2-modulus dividers such as the GPS SP8600 and SP8700 series as shown in Figs. 4 and 5.

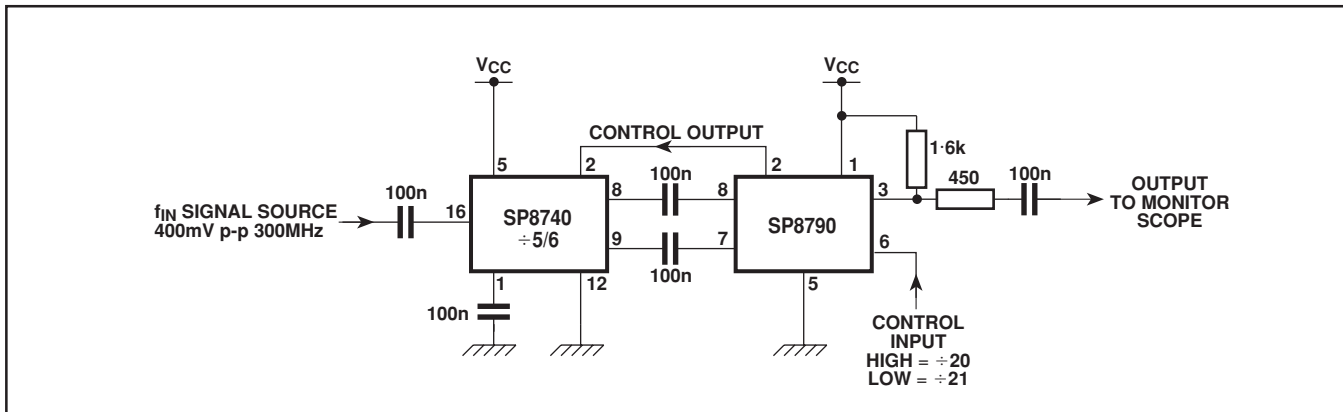

Fig. 4 Test circuit

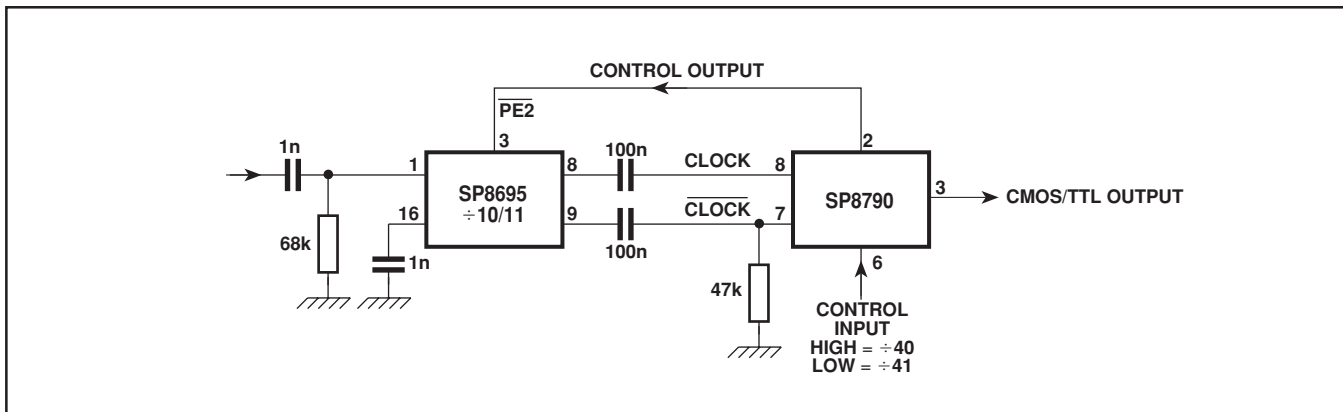
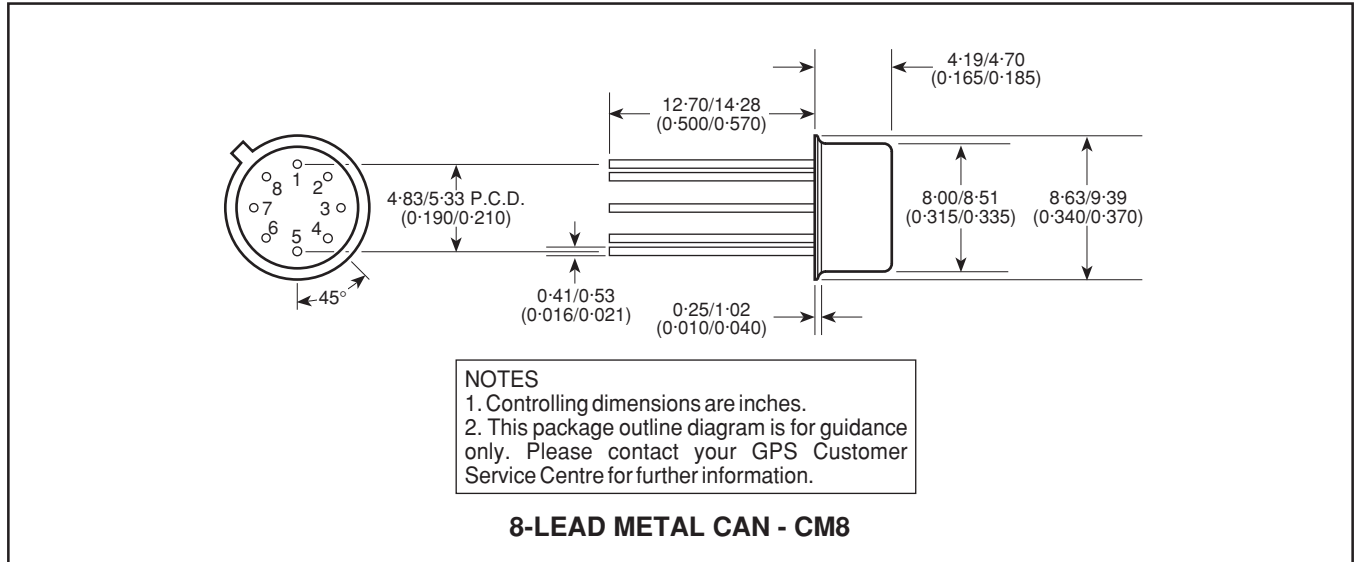

Fig. 5 Typical interfacing to suppress oscillation with no input signal

PACKAGE DETAILS

Dimensions are shown thus: mm (in).



HEADQUARTERS OPERATIONS
GEC PLESSEY SEMICONDUCTORS
 Cheney Manor, Swindon,
 Wiltshire SN2 2QW, United Kingdom.
 Tel: (0793) 518000
 Fax: (0793) 518411

GEC PLESSEY SEMICONDUCTORS
 P.O. Box 660017
 1500 Green Hills Road,
 Scotts Valley, CA95067-0017
 United States of America.
 Tel (408) 438 2900
 Fax: (408) 438 5576

CUSTOMER SERVICE CENTRES

- **FRANCE & BENELUX** Les Ulis Cedex Tel: (1) 64 46 23 45 Fax : (1) 64 46 06 07
- **GERMANY** Munich Tel: (089) 3609 06-0 Fax : (089) 3609 06-55
- **ITALY** Milan Tel: (02) 66040867 Fax: (02) 66040993
- **JAPAN** Tokyo Tel: (3) 5276-5501 Fax: (3) 5276-5510
- **NORTH AMERICA** Scotts Valley, USA Tel: (408) 438 2900 Fax: (408) 438 7023.
- **SOUTH EAST ASIA** Singapore Tel: (65) 3827708 Fax: (65) 3828872
- **SWEDEN** Stockholm Tel: 46 8 702 97 70 Fax: 46 8 640 47 36
- **UK, EIRE, DENMARK, FINLAND & NORWAY**
 Swindon Tel: (0793) 518510 Fax : (0793) 518582

These are supported by Agents and Distributors in major countries world-wide.

© GEC Plessey Semiconductors 1994 Publication No. DS3675 Issue No. 1.2 March 1994

This publication is issued to provide information only which (unless agreed by the Company in writing) may not be used, applied or reproduced for any purpose nor form part of any order or contract nor to be regarded as a representation relating to the products or services concerned. No warranty or guarantee express or implied is made regarding the capability, performance or suitability of any product or service. The Company reserves the right to alter without prior knowledge the specification, design or price of any product or service. Information concerning possible methods of use is provided as a guide only and does not constitute any guarantee that such methods of use will be satisfactory in a specific piece of equipment. It is the user's responsibility to fully determine the performance and suitability of any equipment using such information and to ensure that any publication or data used is up to date and has not been superseded. These products are not suitable for use in any medical products whose failure to perform may result in significant injury or death to the user. All products and materials are sold and services provided subject to the Company's conditions of sale, which are available on request.



**For more information about all Zarlink products
visit our Web Site at
www.zarlink.com**

Information relating to products and services furnished herein by Zarlink Semiconductor Inc. or its subsidiaries (collectively "Zarlink") is believed to be reliable. However, Zarlink assumes no liability for errors that may appear in this publication, or for liability otherwise arising from the application or use of any such information, product or service or for any infringement of patents or other intellectual property rights owned by third parties which may result from such application or use. Neither the supply of such information or purchase of product or service conveys any license, either express or implied, under patents or other intellectual property rights owned by Zarlink or licensed from third parties by Zarlink, whatsoever. Purchasers of products are also hereby notified that the use of product in certain ways or in combination with Zarlink, or non-Zarlink furnished goods or services may infringe patents or other intellectual property rights owned by Zarlink.

This publication is issued to provide information only and (unless agreed by Zarlink in writing) may not be used, applied or reproduced for any purpose nor form part of any order or contract nor to be regarded as a representation relating to the products or services concerned. The products, their specifications, services and other information appearing in this publication are subject to change by Zarlink without notice. No warranty or guarantee express or implied is made regarding the capability, performance or suitability of any product or service. Information concerning possible methods of use is provided as a guide only and does not constitute any guarantee that such methods of use will be satisfactory in a specific piece of equipment. It is the user's responsibility to fully determine the performance and suitability of any equipment using such information and to ensure that any publication or data used is up to date and has not been superseded. Manufacturing does not necessarily include testing of all functions or parameters. These products are not suitable for use in any medical products whose failure to perform may result in significant injury or death to the user. All products and materials are sold and services provided subject to Zarlink's conditions of sale which are available on request.

Purchase of Zarlink's I²C components conveys a licence under the Philips I²C Patent rights to use these components in and I²C System, provided that the system conforms to the I²C Standard Specification as defined by Philips.

Zarlink, ZL and the Zarlink Semiconductor logo are trademarks of Zarlink Semiconductor Inc.

Copyright Zarlink Semiconductor Inc. All Rights Reserved.

TECHNICAL DOCUMENTATION - NOT FOR RESALE
