

## SMT850N High Performance Infrared TOP IR LED

SMT850N consists of an AlGaAs LED mounted on the lead frame as TOP LED package and is 20mW typical of output power.

It emits a spectral band of radiation at 850nm.

### ◆ Specifications

- |                     |               |
|---------------------|---------------|
| 1) Product Name     | TOP IR LED    |
| 2) Type No.         | SMT850N       |
| 3) Chip             |               |
| (1) Chip Material   | AlGaAs        |
| (2) Chip Dimension  | 0.4mm*0.4mm   |
| (3) Peak Wavelength | 850nm typ.    |
| 4) Package          |               |
| (1) Lead Frame Die  | Silver Plated |
| (2) Package Resin   | PPA Resin     |
| (3) Lens            | Epoxy Resin   |

### ◆ Outer dimension (Unit: mm)

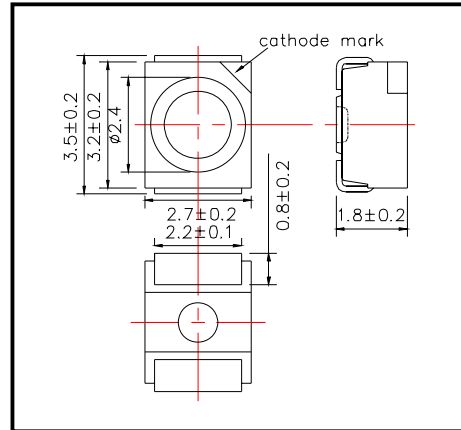

### ◆ Electro-Optical Characteristics [Ta=25°C]

Item	Symbol	Maximum Rated Value	Unit	Ambient Temperature
Power Dissipation	P <sub>D</sub>	160	mW	Ta=25°C
Forward Current	I <sub>F</sub>	100	mA	Ta=25°C
Pulse Forward Current	I <sub>FP</sub>	1,000	mA	Ta=25°C
Reverse Voltage	V <sub>R</sub>	5	V	Ta=25°C
Operating Temperature	T <sub>OPR</sub>	-20 ~ +80	°C	
Storage Temperature	T <sub>STG</sub>	-30 ~ +80	°C	
Soldering Temperature	T <sub>SOL</sub>	240	°C	

‡Pulse Forward Current condition: Duty=1% and Pulse Width=10us.

‡Soldering condition: Soldering condition must be completed within 3 seconds at 230°C

### ◆ Electro-Optical Characteristics [Ta=25°C]

Item	Symbol	Condition	Minimum	Typical	Maximum	Unit
Forward Voltage	V <sub>F</sub>	I <sub>F</sub> =50mA DC		1.45	1.60	V
		I <sub>F</sub> =100mA, tp=20ms		1.50	1.8	
Reverse Current	I <sub>R</sub>	V <sub>R</sub> =5V			10	uA
Total Radiated Power	P <sub>O</sub>	I <sub>F</sub> =50mA DC	15.0	20.0		mW
		I <sub>F</sub> =100mA, tp=20ms		40.0		
Radiant Intensity	I <sub>E</sub>	I <sub>F</sub> =50mA DC		10		mW/sr
		I <sub>F</sub> =100mA, tp=20ms		20		
Peak Wavelength	λ <sub>P</sub>	I <sub>F</sub> =50mA DC	840	850	860	nm
Half Width	Δλ	I <sub>F</sub> =50mA DC		40		nm
Viewing Half Angle	θ <sub>1/2</sub>	I <sub>F</sub> =50mA DC		±55		deg.
Rise Time	t <sub>r</sub>	I <sub>F</sub> =50mA DC		15		ns
Fall Time	t <sub>f</sub>	I <sub>F</sub> =50mA DC		10		ns

‡Total Radiated Power is measured by Photodyne #500

‡Radiant Intensity is measured by Tektronix J-6512.

### Marubeni America Corporation

3945 Freedom Circle, Suite 1000, Santa Clara, CA 95054  
 408-330-0650 (Ext. 323), 408-330-0655 (Fax), [sales@tech-led.com](mailto:sales@tech-led.com)