

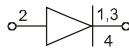

MOLDING TYPE SMD LED LAMPS

GH-5168-L1 Single-Color Series

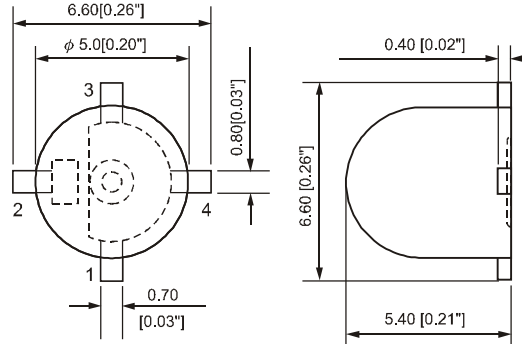

For Reflow Soldering

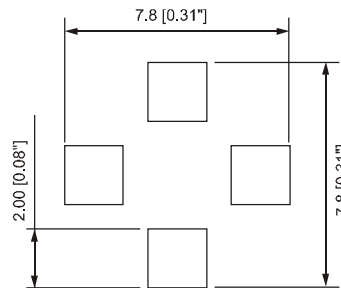

NOTES: 1.All dimensions are in millimeters(inches);
2.Tolerances are $\pm 0.2\text{mm}(.008\text{inch})$ unless otherwise noted;
3.Resin color: water clear.

■ Absolute Maximun Ratings

	UNIT	SPEC.
IF	mA	30
IFp	mA	120
VR	V	5
Topr	°C	-20~+80
Tstg	°C	-20~+100

Part No.	Material	Emitted Color	Lens Appearance	V _f (V)		λ (nm)		I _v (mcd)	Viewing Angle 2 1/2θ
				Typ.	Max.	λ _d	λ _p	Typ.	
RSDPM8T1-L1G	AlGaInP	Red	Water Clear	1.90	2.40	631	640	52	30°
OLDPM8T1-L1G	AlGaInP	Orange		1.90	2.40	624	635	67	
ALDPM8T1-L1G	AlGaInP	Amber		1.90	2.40	595	600	75	
YVDPM8T1-L1E	AlGaInP	Yellow		2.00	2.50	593	595	57	
GBDPM8T1-L1G	AlGaInP	Green		2.10	2.60	578	575	37	
GEIPM8T1-L1G	InGaN	Green		3.20	3.80	527	525	120	
BJJPM8T1-L1H	GaN	Blue		3.40	4.00	465	460	36	
BVEPM8T1-L1C	GaN/SiC	Blue		4.00	4.50	465	430	8	



MOLDING TYPE SMD LED LAMPS

GH-5168-L1 Multi-Color Series

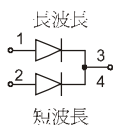
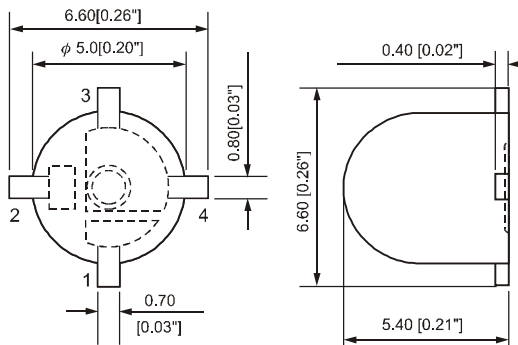

For Reflow Soldering

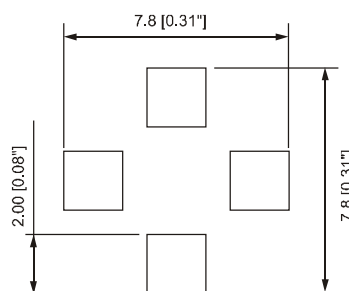

NOTES: 1.All dimensions are in millimeters(inches);
 2.Tolerances are $\pm 0.2\text{mm}$ (.008inch) unless otherwise noted;
 3.Resin color: water clear.

Absolute Maximum Ratings

	UNIT	SPEC.
IF	mA	30
IFp	mA	120
VR	V	5
Topr	°C	-20~+80
Tstg	°C	-20~+100

Part No.	Material	Emitted Color	Lens Appearance	V _r (V)		λ (nm)		I _v (mcd)	Viewing Angle 2 1/2 θ	
				Typ.	Max.	λ_d	λ_p	Typ.		
MPB9M8T4-L1G	AlGaInP	Red	Water	1.90	2.40	631	640	52	30°	
	AlGaInP	Green		2.10	2.60	578	575	37		
MPATM8T4-L1E	GaAsP	Orange		2.00	2.50	622	635	10		
	GaP	Green		2.20	2.70	570	565	16		
MPB2M8T4-L1E	GaAsP	Amber		Clear	2.00	2.50	603	610		11
	GaP	Green			2.20	2.70	570	565		16
MPBHM8T4-L1H	InGaN	Green			3.20	3.60	527	525		120
	GaInN	Blue			3.40	4.00	468	460		52



MOLDING TYPE SMD LED LAMPS

GH-5168-L1 Full-Color Series

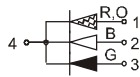
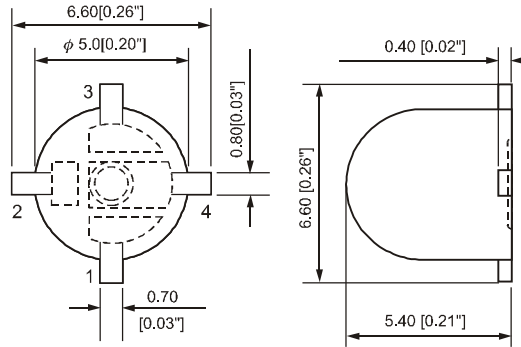

For Reflow Soldering

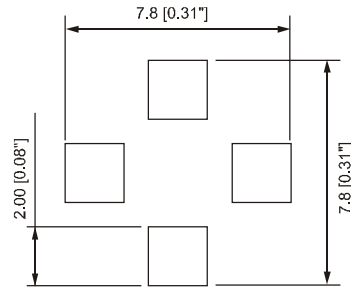

NOTES: 1. All dimensions are in millimeters (inches);
 2. Tolerances are $\pm 0.2\text{mm}$ ($.008\text{inch}$) unless otherwise noted;
 3. Resin color: water clear.

Absolute Maximum Ratings

	UNIT	SPEC.
IF	mA	30
IFp	mA	120
VR	V	5
Topr	°C	-20~+80
Tstg	°C	-20~+100

Part No.	Material	Emitted Color	Lens Appearance	V _f (V)		λ (nm)		I _v (mcd)	Viewing Angle 2 1/2 θ
				Typ.	Max.	λ_d	λ_p	Typ.	
WPB368W6-L1E	GaAlAs	Red	Water	1.80	2.30	643	656	20	30°
	GaP	Green		2.15	2.60	572	566	17	
	GaN/SiC	Blue		4.00	4.50	465	430	8	
WPAG68W6-L1G	AlGaInP	Red	Clear	1.90	2.40	631	643	52	
	InGaN	Green		3.20	3.60	527	525	120	
	GaInN	Blue		3.30	3.80	468	465	38	
WPAH68W6-L1G	AlGaInP	Orange	Clear	1.95	2.50	615	620	75	
	InGaN	Green		3.30	4.00	509	505	120	
	GaInN	Blue		3.30	3.80	468	465	38	