

# Schottky PowerMod

## CPT60080 — CPT600100

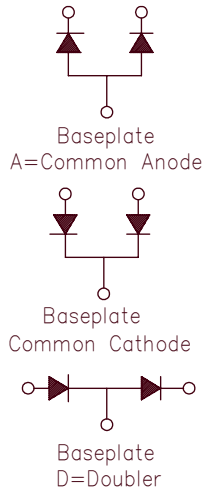
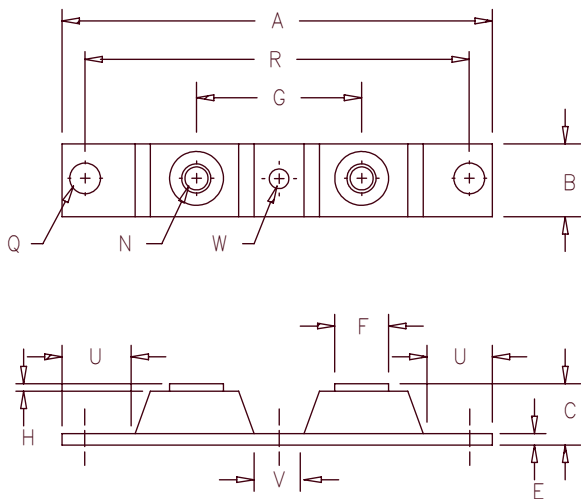

Notes:  
Baseplate: Nickel plated copper

Dim.	Inches		Millimeters		Notes
	Min.	Max.	Min.	Max.	
A	---	3.630	---	92.20	
B	0.700	0.800	17.78	20.32	
C	---	.680	---	17.28	
E	0.120	0.130	3.05	3.30	
F	0.490	0.510	12.45	12.95	
G	1.375 BSC		34.92 BSC		
H	0.050	---	1.25	---	
N	---	---	---	---	1/4-20
Q	0.275	0.290	6.99	7.37	Dia.
R	3.150 BSC		80.01 BSC		
U	0.600	---	15.24	---	
V	0.312	0.340	7.92	8.64	
W	0.180	0.195	4.57	4.95	Dia.

Microsemi Catalog Number	Industry Part Number	Working Peak Reverse Voltage	Repetitive Peak Reverse Voltage
CPT60080*	MBR60080CT	80V	80V
CPT60090*		90V	90V
CPT600100*	MBR600100CT	100V	100V

\*Add Suffix A for Common Anode, D for Doubler

- Schottky Barrier Rectifier
- Guard ring protection
- 600 Amperes/ 80 to 100 Volts
- 175°C junction temperature
- Reverse energy tested
- ROHS Compliant

### Electrical Characteristics

Average forward current per pkg	I <sub>F(AV)</sub> 600 Amps	T <sub>C</sub> = 132°C, Square wave, R <sub>θJC</sub> = 0.10°C/W
Average forward current per leg	I <sub>F(AV)</sub> 300 Amps	T <sub>C</sub> = 132°C, Square wave, R <sub>θJC</sub> = 0.20°C/W
Maximum surge current per leg	I <sub>FSM</sub> 6000 Amps	8.3ms, half sine, T <sub>J</sub> = 175°C
Maximum repetitive reverse current per leg	I <sub>R(OV)</sub> 2 Amps	f = 1 KHZ, 25°C, 1μsec square wave
Max peak forward voltage per leg	V <sub>FM</sub> 0.85 Volts	I <sub>FM</sub> = 300A: T <sub>J</sub> = 25°C
Max peak forward voltage per leg	V <sub>FM</sub> 0.62 Volts	I <sub>FM</sub> = 300A: T <sub>J</sub> = 175°C
Max peak reverse current per leg	I <sub>RM</sub> 75 mA	V <sub>RRM</sub> , T <sub>J</sub> = 125°C*
Max peak reverse current per leg	I <sub>RM</sub> 8.0 mA	V <sub>RRM</sub> , T <sub>J</sub> = 25°C
Typical junction capacitance per leg	C <sub>J</sub> 9000 pF	V <sub>R</sub> = 5.0V, T <sub>C</sub> = 25°C

\*Pulse test: Pulse width 300μsec, Duty cycle 2%

### Thermal and Mechanical Characteristics

Storage temp range	T <sub>STG</sub>	-55°C to 175°C
Operating junction temp range	T <sub>J</sub>	-55°C to 175°C
Max thermal resistance per leg	R <sub>θJC</sub>	0.20°C/W Junction to case
Max thermal resistance per pkg	R <sub>θJC</sub>	0.10°C/W Junction to case
Typical thermal resistance (greased)	R <sub>θCS</sub>	0.08°C/W Case to sink
Terminal Torque		35-50 inch pounds
Mounting Base Torque (outside holes)		30-40 inch pounds
Mounting Base Torque (center hole)		8-10 inch pounds
center hole must be torqued first		
Weight		2.8 ounces (78 grams) typical

# CPT60080 — CPT600100

Figure 1  
Typical Forward Characteristics — Per Leg

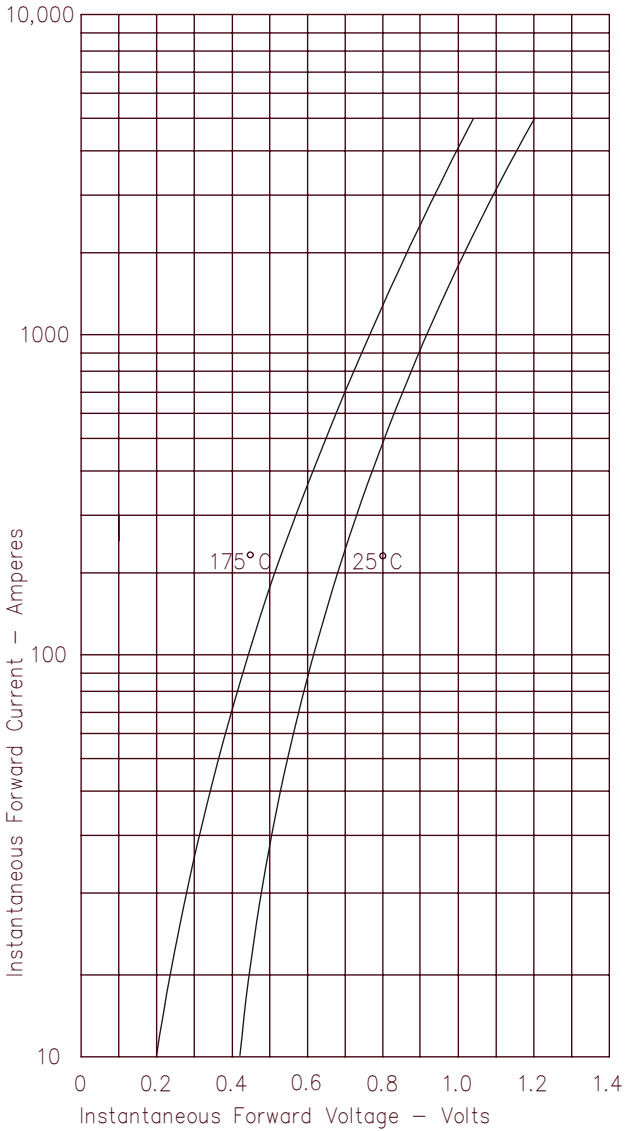

Figure 3  
Typical Junction Capacitance — Per Leg

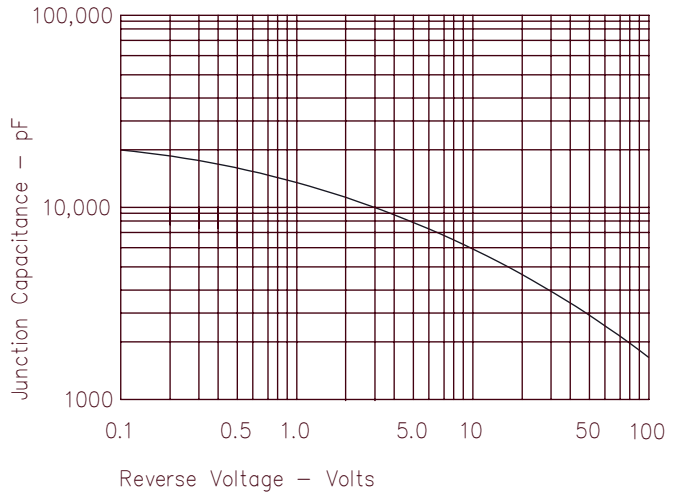

Figure 4  
Forward Current Derating — Per Leg

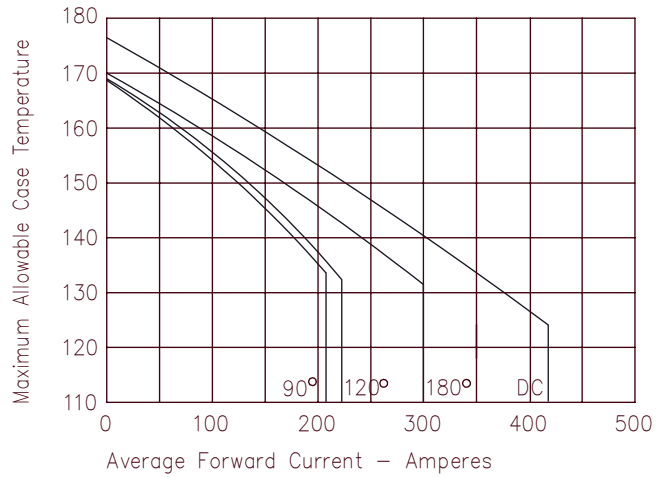

Figure 2  
Typical Reverse Characteristics — Per Leg

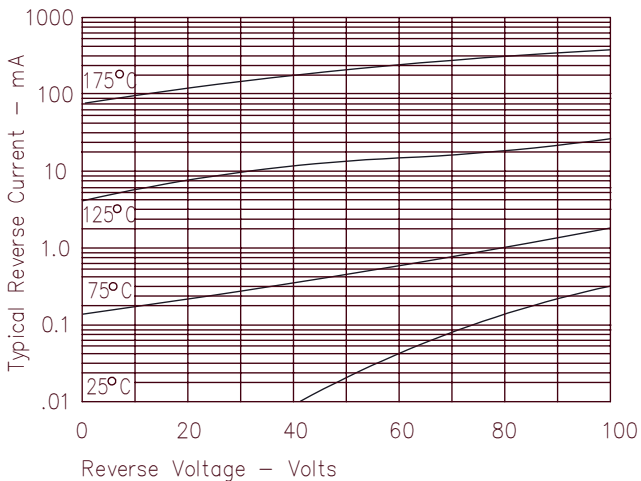

Figure 5  
Maximum Forward Power Dissipation — Per Leg

