

ETD cores and accessories

ETD29

CORE SETS

Effective core parameters

SYMBOL	PARAMETER	VALUE	UNIT
$\Sigma(l/A)$	core factor (C1)	0.947	mm ⁻¹
V_e	effective volume	5470	mm ³
l_e	effective length	72	mm
A_e	effective area	76	mm ²
A_{min}	minimum area	71	mm ²
m	mass of core half	≈14	g

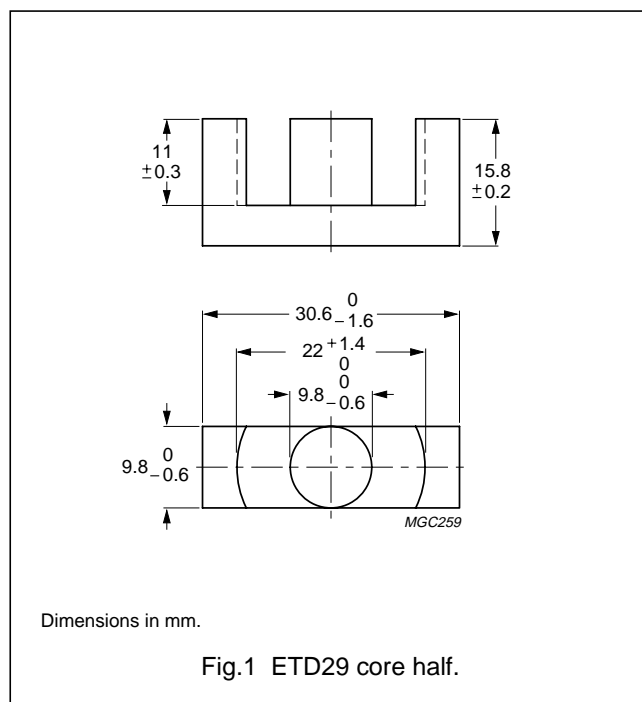

Core halves

Clamping force 40 ± 20 N. Gapped cores are available on request.

GRADE	A_L (nH)	μ_e	AIR GAP (μm)	TYPE NUMBER
3C30 <small>des</small>	$1900 \pm 25\%$	≈1500	≈0	ETD29-3C30
3C85	$2350 \pm 25\%$	≈1850	≈0	ETD29-3C85
3C90 <small>des</small>	$2350 \pm 25\%$	≈1850	≈0	ETD29-3C90
3F3 <small>des</small>	$2200 \pm 25\%$	≈1700	≈0	ETD29-3F3

Properties of core sets under power conditions

GRADE	B (mT) at	CORE LOSS (W) at		
	H = 250 A/m; f = 25 kHz; T = 100 °C	f = 25 kHz; $\hat{B} = 200$ mT; T = 100 °C	f = 100 kHz; $\hat{B} = 100$ mT; T = 100 °C	f = 400 kHz; $\hat{B} = 50$ mT; T = 100 °C
3C30	≥360	≤0.55	≤0.60	–
3C85	≥320	≤0.80	≤0.90	–
3C90	≥330	≤0.55	≤0.60	–
3F3	≥320	–	≤0.65	≤1.1

ETD cores and accessories

ETD29

COIL FORMER

General data 13-pins ETD29 coil former

PARAMETER	SPECIFICATION
Coil former material	polybutyleneterephthalate (PBT), glass-reinforced, flame retardant in accordance with "UL 94V-0"; UL file number E45329(R)
Pin material	copper-tin alloy (CuSn), tin-lead alloy (SnPb) plated
Maximum operating temperature	155 °C, "IEC 85" class F
Resistance to soldering heat	"IEC 68-2-20", Part 2, Test Tb, method 1B, 350 °C, 3.5 s
Solderability	"IEC 68-2-20", Part 2, Test Ta, method 1

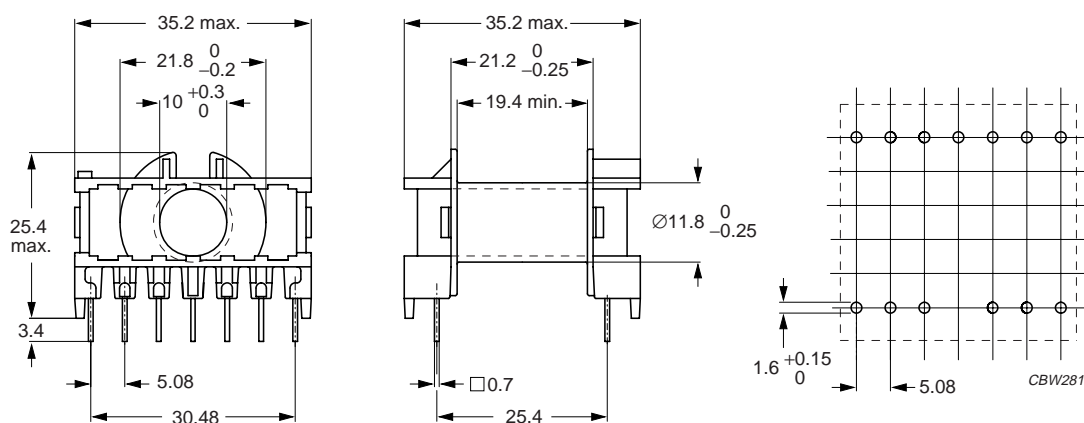

Dimensions in mm.

Fig.2 ETD29 coil former; 13-pins.

Winding data for 13-pins ETD29 coil former

NUMBER OF SECTIONS	WINDING AREA (mm ²)	MINIMUM WINDING WIDTH (mm)	AVERAGE LENGTH OF TURN (mm)	TYPE NUMBER
1	90	19.4	53	CPH-ETD29-1S-13P

ETD cores and accessories

ETD29

MOUNTING PARTS

General data

ITEM	REMARKS	FIGURE	TYPE NUMBER
Mounting clip	material: stainless steel	3	CLI-ETD29

