



## 5302

## NPN SILICON TRANSISTOR

### HIGH VOLTAGE NPN TRANSISTOR

#### DESCRIPTION

The UTC 5302 is a NPN silicon planar transistor and suited to be used in power amplifier applications.

#### FEATURES

- \* Makes efficient anti-saturation operation
- \* Low variable storage-time spread
- \* Low base drive
- \* Very suitable for half bridge light ballast application

#### SYMBOL

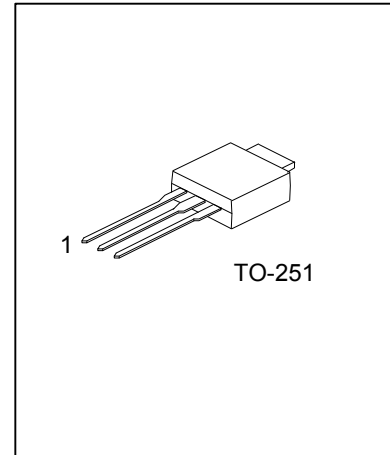
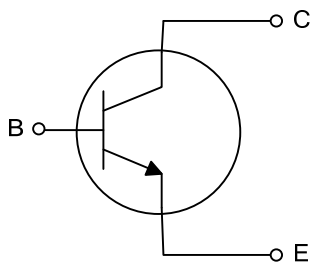

#### ORDERING INFORMATION

Ordering Number		Package	Pin Assignment			Packing
Lead Free	Halogen Free		1	2	3	
5302L-TM3-T	5302G-TM3-T	TO-251	B	C	E	Tube

Note: Pin Assignment: B: Base C: Collector E: Emitter

<p>5302L-TM3-T</p>	<p>(1) Packing Type</p> <p>(2) Package Type</p> <p>(3) Lead Free</p>	<p>(1) T: Tube</p> <p>(2) TM3: TO-251</p> <p>(3) G: Halogen Free, L: Lead Free</p>
--------------------	--	--

■ ABSOLUTE MAXIMUM RATING (Ta=25°C, unless otherwise specified)

PARAMETER	SYMBOL	RATINGS	UNIT
Collector-Base Voltage	V <sub>CBO</sub>	800	V
Collector-Emitter Voltage	V <sub>CEO</sub>	400	V
Emitter-Base Voltage	V <sub>EBO</sub>	10	V
Collector Current	I <sub>C</sub>	2	A
Collector Peak Current (tp<5ms)	I <sub>CM</sub>	4	A
Base Current	I <sub>B</sub>	1	A
Base Peak Current (tp<5ms)	I <sub>BM</sub>	2	A
Power Dissipation (T <sub>C</sub> ≤25°C)	P <sub>D</sub>	25	W
Junction Temperature	T <sub>J</sub>	+150	°C
Storage Temperature	T <sub>STG</sub>	-65 ~ +150	°C

Note: Absolute maximum ratings are those values beyond which the device could be permanently damaged.  
 Absolute maximum ratings are stress ratings only and functional device operation is not implied.

■ THERMAL DATA

PARAMETER	SYMBOL	RATINGS	UNIT
Junction to Ambient	θ <sub>JA</sub>	100	°C/W
Junction to Case	θ <sub>JC</sub>	5	°C/W

■ ELECTRICAL CHARACTERISTICS (Ta = 25°C, unless otherwise specified)

PARAMETER	SYMBOL	TEST CONDITIONS	MIN	TYP	MAX	UNIT
<b>OFF CHARACTERISTICS</b>						
Collector-Emitter Breakdown Voltage	$BV_{CEO}$	$I_C=10mA, I_E=0$ (Note)	400			V
Collector-Base Breakdown Voltage	$BV_{CBO}$	$I_C=1mA, I_B=0$	800			V
Emitter-Base Breakdown Voltage	$BV_{EBO}$	$I_E=1mA, I_C=0$	10			V
Collector Cutoff Current	$I_{CBO}$	$V_{CB}=800V, I_E=0$			1	$\mu A$
Emitter Cutoff Current	$I_{EBO}$	$V_{EB}=9V, I_C=0$			1	$\mu A$
<b>ON CHARACTERISTICS</b>						
DC Current Gain	$h_{FE1}$	$V_{CE}=5V, I_C=10mA$	10			
	$h_{FE2}$	$V_{CE}=5V, I_C=400mA$	10		30	
	$h_{FE3}$	$V_{CE}=5V, I_C=1A$	5			
Collector-Emitter Saturation Voltage	$V_{CE(SAT1)}$	$I_C=0.5A, I_B=0.1A$ (Note)			0.5	V
	$V_{CE(SAT2)}$	$I_C=1A, I_B=0.25A$ (Note)		1.1	1.5	
Base-Emitter Saturation Voltage	$V_{BE(SAT1)}$	$I_C=0.5A, I_B=0.1A$ (Note)			1.1	V
	$V_{BE(SAT2)}$	$I_C=1A, I_B=0.25A$ (Note)			1.2	
<b>SWITCHING CHARACTERISTICS</b>						
Turn On Time	$t_{ON}$	$V_{CC}=250V, I_C=1A,$		0.15	0.3	$\mu S$
Fall Time	$t_F$	$I_{B1}=I_{B2}=0.2A, t_p=25\mu S$		0.2	0.4	$\mu S$
Storage Time	$t_{STG}$	Duty Cycle<1%		0.5	0.9	$\mu S$

Note: Pulsed duration = 300 $\mu S$ , Duty cycle $\leq$ 2%

■ TYPICAL CHARACTERISTICS

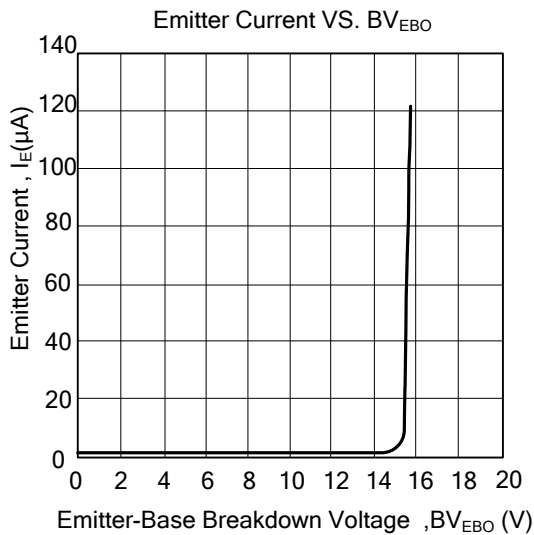
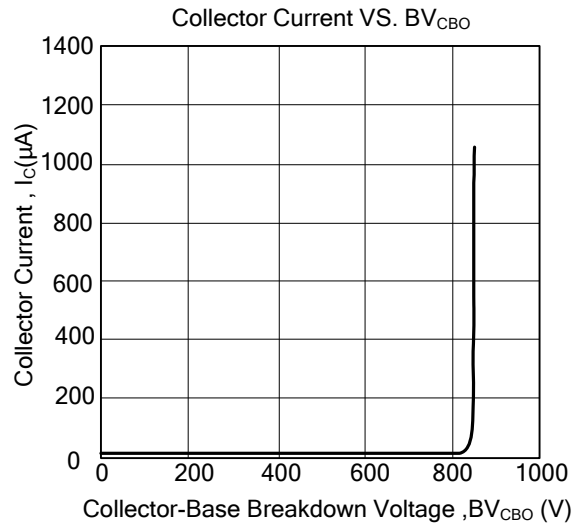
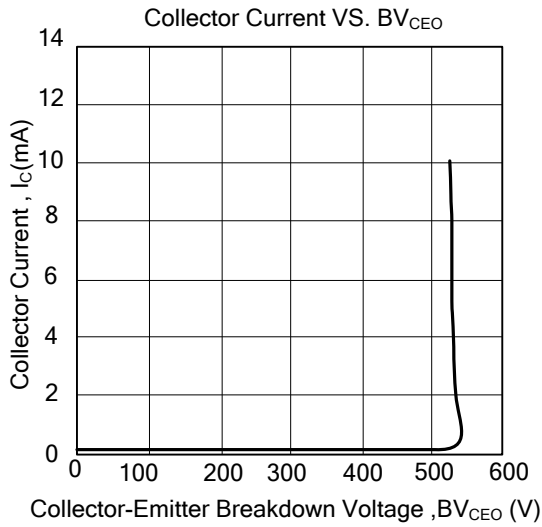

UTC assumes no responsibility for equipment failures that result from using products at values that exceed, even momentarily, rated values (such as maximum ratings, operating condition ranges, or other parameters) listed in products specifications of any and all UTC products described or contained herein. UTC products are not designed for use in life support appliances, devices or systems where malfunction of these products can be reasonably expected to result in personal injury. Reproduction in whole or in part is prohibited without the prior written consent of the copyright owner. The information presented in this document does not form part of any quotation or contract, is believed to be accurate and reliable and may be changed without notice.