

**200 Krad(Si) Ultra Low Dropout  
 Adjustable Linear Regulator  
 Hermetic Package**

**OMR9806SC  
 OMR9806SF  
 +7.5Vin / +6.1 to +7.0Vout @ 3.0A**

**Product Summary**

Part Number	Dropout	Io	V in	Package
OMR9806SC	0.4 V	3.0A	7.5V	MO-078AA
OMR9806SF	0.4 V	3.0A	7.5V	8-Lead Flatpack

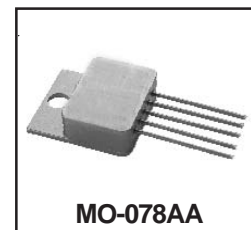

The OMR9806 is a radiation hardened, ultra low dropout adjustable linear regulator designed specifically for space applications. This product has been characterized to a total ionizing dose of 200 Krad (Si) per MIL-STD-883, Method 1019, Condition A at both high and low dose rates under biased and unbiased conditions to account for ELDRS effects in bipolar devices. The ultra low dropout voltage of 0.4V @ 3A makes the part particularly useful for applications requiring low noise and higher efficiency.

**Features:**

- Total dose and low dose capability to 200 Krad(Si) allows use in space applications
- Ultra low dropout voltage of 0.4V@ 3A out significantly reduces power consumption
- Low noise, higher efficiency
- Remote shutdown permits power sequencing to be easily implemented
- Hermetic MO-078AA (TO-258AA) and 8-lead flat pack ensure higher reliability
- K-level screened

**Absolute Maximum Ratings**

Symbol	Parameter	Value	Units
Io	Output Current	3.5	A
Vin	Input Voltage	+8.0	V
Vout	Output Voltage Range	+6.1 to +7.0	V
P <sub>TOT</sub>	Power Dissipation TC=25 °C	19	W
R <sub>THJC</sub>	Thermal Resistance, Junction to Case (MO-078AA)	6.5	°C/W
R <sub>THJC</sub>	Thermal Resistance, Junction to Case (8 lead flatpack)	6.5	°C/W
T <sub>J</sub>	Operating Junction	-55 to +125	°C
T <sub>STG</sub>	Storage Temperature Range	-65 to +150	°C
T <sub>L</sub>	Lead Temperature	300	°C

**Electrical Characteristics @ TA= 25°C (Unless Otherwise Specified)**

Parameter	Conditions	Symbol	Min.	Typ.	Max	Unit
Input Voltage Range-Operating	Io= 3.0A		6.5		8.0	V
Reference Voltage			1.252	1.265	1.278	V
Line Regulation	7.13 ≤ Vin ≤ 7.88, Io= 3.0A 6.75 ≤ Vin ≤ 8, Io= 50mA	Vline	-100 -5		+100 +5	mV mV
Load Regulation	Vin= 7.5V 10ma ≤ Iout ≤ 3.0A	Vload	-20		+20	mV
Dropout Voltage	Io= 3.0A. Vin= 7.5V	Vdrop			0.4	V
Current Limit	Vin= 7.5V, Overcurrent Latchup	Iatch	3.0			A
Ripple Rejection	F= 120 Hz., Vout= Vref		65			dB
Shutdown source current	Vshdn= 5V	Ishdn		200		uA
Shutdown Pin Threshold	Isource= 200uA	Vshdn	1.0		1.6	V
Output Voltage at Shutdown	Vin= 7.5V, Io= 50mA, Shdn= +5.0V	Vout (shdn)	-0.1		+0.1	V

**Electrical Characteristics TA = -55 to +125°C**

Parameter	Conditions	Symbol	Min.	Typ.	Max	Unit
Input Voltage Range-Operating	Io= 3.0A		6.5		8.25	V
Reference Voltage			1.225	1.265	1.305	V
Line Regulation	7.13 ≤ Vin ≤ 7.88, Io= 3.0A 6.75 ≤ Vin ≤ 8, Io= 50mA	Vline	-150 -150		+150 +150	mV mV
Load Regulation	Vin= 7.5V 10ma ≤ Iout ≤ 3.0A	Vload	-150		+150	mV
Dropout Voltage	Io= 3.0A. Vin= 7.5V	Vdrop			0.4	V
Current Limit	Vin= 7.5V, Overcurrent Latchup	Iatch	3.0			A
Ripple Rejection	F= 120 Hz., Vout= Vref		65			dB
Shutdown source current	Vshdn= 5V	Ishdn		200		uA
Shutdown Pin Threshold	Isource= 200uA	Vshdn	1.0		1.6	V
Output Voltage at Shutdown	Vin= 7.5V, Io= 50mA, Shdn= +5.0V	Vout (shdn)	-0.1		+0.1	V

**Simplified Schematic**

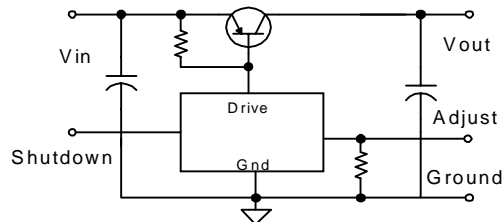

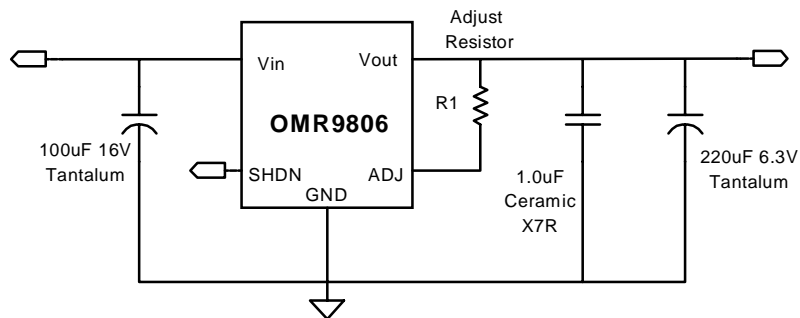
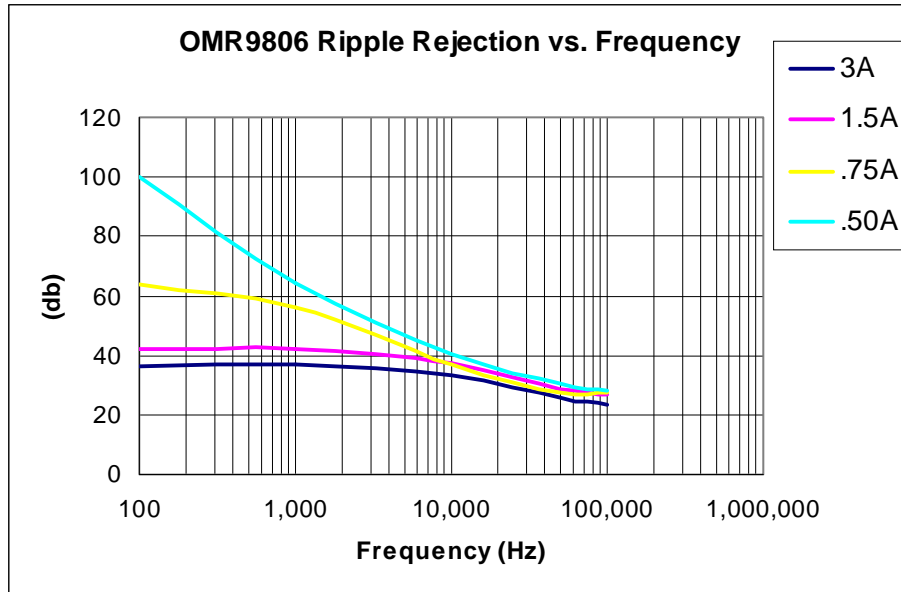

$$V_{out} = V_{ref} \times (1 + R1/1000)$$

In order to maintain regulation and stability specified additional input and output bulk capacitors are recommended. Capacitors recommended above should be low ESR tantalums with tolerances of +/- 20% max. Internal to the product are a 4.7uF input capacitor and a 4.7uF output capacitor in parallel with a 0.33uF ceramic capacitor.

**Shutdown:** The regulator can be shutdown by applying a voltage >1.6V to pin 4. The regulator will restart when the SHDN pin is pulled below the shutdown threshold of 1.0V. If remote shutdown is not required, pin 4 should be connected to GND to insure a safe "off" state.

**OMR9806SC, OMR9806SF**

**Base:** GLIDCOP  
**Pins:** Copper core, Alloy 52  
**Seals:** Glass

Pin Connections

Terminal	Description
1	Vin
2	GND
3	Vout
4	Shutdown
5	Adjust

**Mechanical Outline MO-078AA**

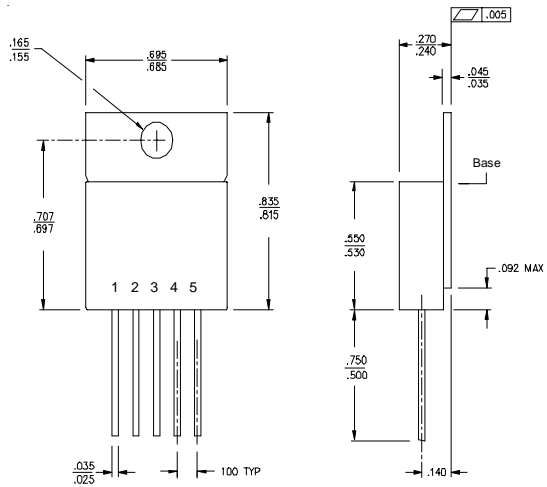

**Mechanical Outline 8-Lead Flat Pack**

**Base:** 1010-1018 C.R.S.  
**Pins:** #52 Alloy, Copper Cored  
**Seals:** Glass – 9013 or Equiv.  
**Finish:** 100-250 Microinches Electroless Nickel Over 50-250 Microinches Electrolytic Nickel.

Pin Connections

Terminal	Description
1,2	GND
3	Shutdown
4	Adjust
5,6	Vout
7,8	Vin

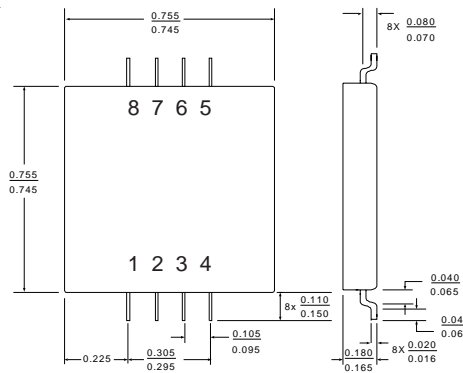

<b>Part Number Nomenclature</b>					
<b>OM</b>	<b>R</b>	<b>9806</b>	<b>X</b>	<b>X</b>	<b>X</b>
Omnirel	Radiation Hardened/Tolerant	Device	S=Isolated N=Non-Isolated	Package	Screening

<b>Part Number</b>	<b>Package Description</b>	<b>Screening</b>
OMR9806SCP	MO-078AA 5 - Lead	100% Final Electrical
OMR9806SCH	MO-078AA 5 - Lead	Class H per MIL-PRF-38534
OMR9806SCK	MO-078AA 5 - Lead	Class K per MIL-PRF-38534
OMR9806SFP	8 -Lead Flat Pack	100% Final Electrical
OMR9806SFH	8 -Lead Flat Pack	Class H per MIL-PRF-38534
OMR9806SFK	8 -Lead Flat Pack	Class K per MIL-PRF-38534

**MIL-PRF-38534 Screening Requirements**

<b>TEST/INSPECTION</b>	<b>SCREENING LEVEL</b>		<b>MIL-STD-883 Method</b>
	<b>Class H</b>	<b>Class K (Space Level)</b>	
Pre Seal Burn-In	Optional	Optional	1030
Nondestructive Bond Pull	N/A	100%	2023
Internal Visual	100%	100%	2017
Temperature Cycle	100%	100%	1010
Constant Acceleration	100%	100%	2001
Mechanical Shock	100%	100%	2002
PIND	N/A	100%	2020
Pre Burn-In Electrical	Optional	100%	
Burn-In	100%	100%	1015
Final Electrical	100%	100%	
Seal	100%	100%	1014
Radiographic	N/A	100%	2012
External Visual	100%	100%	2009