

September 1995

Features

- This Circuit is Processed in Accordance to Mil-Std-883 and is Fully Conformant Under the Provisions of Paragraph 1.2.1.
- Radiation Hardened
 - Functional Total Dose Exceeds 1×10^5 RAD Si
- Pin for Pin Compatible with Harris HI-3XX Series Analog Switches
- Analog Signal Range 15V
- Low Leakage
- Low R_{ON}
- No Latch Up
- Versions for 5V and 15V Digital Systems
- Low Operating Power
- Military Temperature Range -55°C to $+125^{\circ}\text{C}$

Applications

- Sample and Hold i.e. Low Leakage Switching
- Op Amp Gain Switching i.e. Low ON Resistance
- Switched Capacitor Filters
- Low Level Switching Circuits
- Satellites
- Nuclear Reactor Controls
- Military Environments

Description

The HS-3XXRH/883S family of analog switches are monolithic devices fabricated using Radiation Hardened CMOS technology and the Harris dielectric isolation process for latch-up free operation. Improved total dose hardness is obtained by layout (thin oxide tabs extending to a channel stop) and processing (hardened gate oxide). These switches offer low-resistance switching performance for analog voltages up to the supply rails. "ON" resistance is low and stays reasonably constant over the full range of operating voltage and current. "ON" resistance also stays reasonably constant when exposed to radiation, being typically 30Ω pre-rad and 35Ω post 100K RAD-Si. All devices provide break-before-make switching.

The 6 devices in this switch series are differentiated by type of switch action, pinout and digital logic levels. The HS-302/303/384/390RH/883S switches have 5V digital inputs while the HS-306/307RH/883S switches have 15V digital inputs. All devices are available in Ceramic Flatpack and SBDIP packages. The HS-3XXRH/883S switches can directly replace the HI-3XX series devices.

Functional Diagram

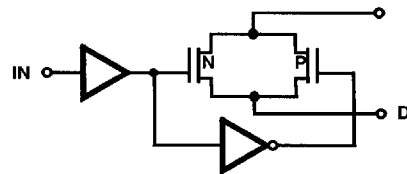

Ordering Information

PART NUMBER	TEMPERATURE RANGE	SCREENING LEVEL	PACKAGE
HS1-302RH/883S	-55°C to $+125^{\circ}\text{C}$	Harris /883 Class S Equivalent	14 Lead SBDIP
HS9-302RH/883S	-55°C to $+125^{\circ}\text{C}$	Harris /883 Class S Equivalent	14 Lead Ceramic Flatpack
HS1-302RH/Sample	$+25^{\circ}\text{C}$	Sample	14 Lead SBDIP
HS9-302RH/Sample	$+25^{\circ}\text{C}$	Sample	14 Lead Ceramic Flatpack
HS1-303RH/883S	-55°C to $+125^{\circ}\text{C}$	Harris /883 Class S Equivalent	14 Lead SBDIP
HS9-303RH/883S	-55°C to $+125^{\circ}\text{C}$	Harris /883 Class S Equivalent	14 Lead Ceramic Flatpack
HS1-303RH/Sample	$+25^{\circ}\text{C}$	Sample	14 Lead SBDIP
HS9-303RH/Sample	$+25^{\circ}\text{C}$	Sample	14 Lead Ceramic Flatpack
HS1-306RH/883S (Note 1)	-55°C to $+125^{\circ}\text{C}$	Harris /883 Class S Equivalent	14 Lead SBDIP
HS9-306RH/883S (Note 1)	-55°C to $+125^{\circ}\text{C}$	Harris /883 Class S Equivalent	14 Lead Ceramic Flatpack

CAUTION: These devices are sensitive to electrostatic discharge Users should follow proper I.C. Handling Procedures.

Copyright © Harris Corporation 1995

Spec Number **518526**

File Number **3067.1**

1

4302271 0063366 104

HS-3XXRH/883S

Ordering Information (Continued)

PART NUMBER	TEMPERATURE RANGE	SCREENING LEVEL	PACKAGE
HS1-306RH/Sample (Note 1)	+25°C	Sample	14 Lead SBDIP
HS9-306RH/Sample (Note 1)	+25°C	Sample	14 Lead Ceramic Flatpack
HS1-307RH/883S	-55°C to +125°C	Harris /883 Class S Equivalent	14 Lead SBDIP
HS9-307RH/883S	-55°C to +125°C	Harris /883 Class S Equivalent	14 Lead Ceramic Flatpack
HS1-307RH/Sample	+25°C	Sample	14 Lead SBDIP
HS9-307RH/Sample	+25°C	Sample	14 Lead Ceramic Flatpack
HS1-384RH/883S (Note 1)	-55°C to +125°C	Harris /883 Class S Equivalent	16 Lead SBDIP
HS9-384RH/883S (Note 1)	-55°C to +125°C	Harris /883 Class S Equivalent	16 Lead Ceramic Flatpack
HS1-384RH/Sample (Note 1)	+25°C	Sample	16 Lead SBDIP
HS9-384RH/Sample (Note 1)	+25°C	Sample	16 Lead Ceramic Flatpack
HS1-390RH/883S	-55°C to +125°C	Harris /883 Class S Equivalent	16 Lead SBDIP
HS9-390RH/883S	-55°C to +125°C	Harris /883 Class S Equivalent	16 Lead Ceramic Flatpack
HS1-390RH/Sample	+25°C	Sample	16 Lead SBDIP
HS9-390RH/Sample	+25°C	Sample	16 Lead Ceramic Flatpack

NOTE:

1. Not recommended for new design.

Pinouts (Switch States are for Logic "1" Inputs)

**14 LEAD CERAMIC DUAL-IN-LINE
METAL SEAL PACKAGE (SBDIP)
MIL-STD-1835 CDIP2-T14
TOP VIEW**

**16 LEAD CERAMIC DUAL-IN-LINE
METAL SEAL PACKAGE (SBDIP)
MIL-STD-1835 CDIP2-T16
TOP VIEW**

DUAL DPST
HS-302RH/883S
HS-306RH/883S

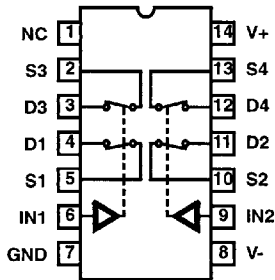

LOGIC	SWITCH 1 - 4
0	OFF
1	ON

DUAL SPDT
HS-303RH/883S
HS-307RH/883S

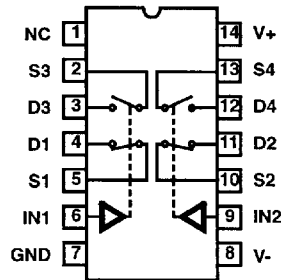

LOGIC	SW1	SW2	SW3	SW4
0	OFF	OFF	ON	ON
1	ON	ON	OFF	OFF

DUAL DPST
HS-384RH/883S

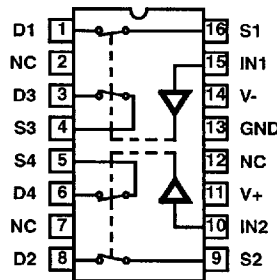

LOGIC	SWITCH 1 - 4
0	OFF
1	ON

DUAL SPDT
HS-390RH/883S

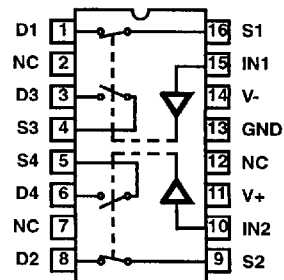

LOGIC	SW1	SW2	SW3	SW4
0	OFF	OFF	ON	ON
1	ON	ON	OFF	OFF

HS-3XXRH/883S

Pinouts (Switch States are for Logic "1" Inputs) (Continued)

14 LEAD CERAMIC METAL SEAL FLATPACK PACKAGE (FLATPACK) MIL-STD-1835 CDIP3-F14 TOP VIEW

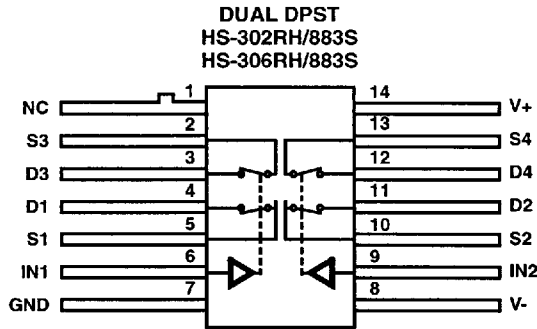

LOGIC	SWITCH 1 - 4
0	OFF
1	ON

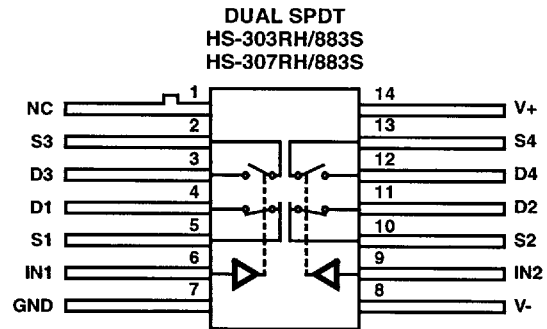

LOGIC	SW1 AND SW2	SW3 AND SW4
0	OFF	ON
1	ON	OFF

16 LEAD CERAMIC METAL SEAL FLATPACK PACKAGE (FLATPACK) MIL-STD-1835 CDIP4-F16 TOP VIEW

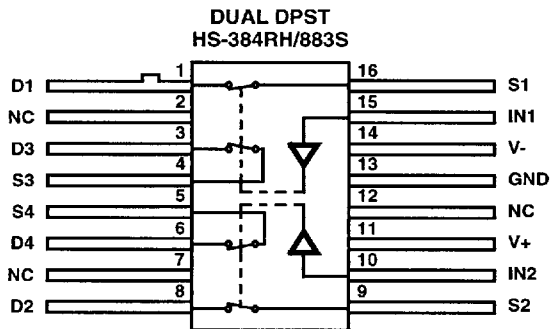

LOGIC	SWITCH 1 - 4
0	OFF
1	ON

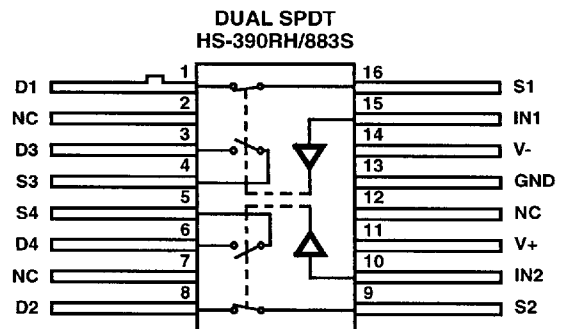

LOGIC	SW1 AND SW2	SW3 AND SW4
0	OFF	ON
1	ON	OFF

Specifications HS-3XXRH/883S

Absolute Maximum Ratings

Supply Voltage Between V+ and V-	+44V
+VSUPPLY to Ground	+22V
-VSUPPLY to Ground	-22V
Analog Input Overvoltages:	
+VS	+VSUPPLY +1.5V
-VS	-VSUPPLY - 1.5V
Digital Input Overvoltage:	
+VA	+VSUPPLY +4V
-VA	-VSUPPLY -4V
Peak Current, S or D Pulsed at 1ms, 10% Duty Cycle Max.	40mA
Continuous Current	10mA
Storage Temperature Range	-65°C to +150°C
Junction Temperature	+175°C
Lead Temperature (soldering 10s)	≤ +300°C

Reliability Information

Thermal Resistance	θ_{JA}	θ_{JC}
14 Lead SBDIP Package	70°C/W	19°C/W
14 Lead Ceramic Flatpack Package	105°C/W	17°C/W
16 Lead SBDIP Package	70°C/W	19°C/W
16 Lead Ceramic Flatpack Package	105°C/W	17°C/W
Maximum Package Power Dissipation at +125°C Ambient		
14 Lead SBDIP Package	0.71W	
14 Lead Ceramic Flatpack Package	0.48W	
16 Lead SBDIP Package	0.71W	
16 Lead Ceramic Flatpack Package	0.48W	
If device power exceeds package dissipation capability, provide heat sinking or derate linearly at the following rate:		
14 Lead SBDIP Package	14.3mW/°C	
14 Lead Ceramic Flatpack Package	9.5mW/°C	
16 Lead SBDIP Package	14.3mW/°C	
16 Lead Ceramic Flatpack Package	9.5mW/°C	

CAUTION: Stresses above those listed in "Absolute Maximum Ratings" may cause permanent damage to the device. This is a stress only rating and operation of the device at these or any other conditions above those indicated in the operational sections of this specification is not implied.

Operating Conditions

Operating Supply Voltage (± VSupply)	±15V	Operating Temperature Range	-55°C to +125°C
--	------	-----------------------------------	-----------------

TABLE 1. HS-302RH/303RH/384RH/390RH/883S DC ELECTRICAL PERFORMANCE CHARACTERISTICS

Device Guaranteed and 100% Tested. Unless Otherwise Specified: V- = -15V, V+ = +15V, VAH = +4.0V, VAL = 0.8V

PARAMETER	SYMBOL	CONDITIONS	GROUP A SUB-GROUPS	TEMPERATURE	LIMITS		UNITS
					MIN	MAX	
"Switch On" Resistance	+RDS	VD = 10V, IS = -10mA, S1/S2/S3/S4	1	+25°C	-	50	Ω
			2, 3	-55°C to +125°C	-	75	Ω
	-RDS	VD = -10V, IS = 10mA, S1/S2/S3/S4	1	+25°C	-	50	Ω
			2, 3	-55°C to +125°C	-	75	Ω
Leakage Current Into the Source Terminal of an "Off" Switch	+IS(OFF)	VS = +14V, VD = -14V, S1/S2/S3/S4	1	+25°C	-2	2	nA
			2, 3	-55°C to +125°C	-100	100	nA
	-IS(OFF)	VS = -14V, VD = +14V, S1/S2/S3/S4	1	+25°C	-2	2	nA
			2, 3	-55°C to +125°C	-100	100	nA
Leakage Current into the Drain Terminal of an "Off" Switch	+ID(OFF)	VS = -14V, VD = +14V, S1/S2/S3/S4	1	+25°C	-2	2	nA
			2, 3	-55°C to +125°C	-100	100	nA
	-ID(OFF)	VS = +14V, VD = -14V, S1/S2/S3/S4	1	+25°C	-2	2	nA
			2, 3	-55°C to +125°C	-100	100	nA
Leakage Current from an "On" Driver Into the Switch (Drain & Source)	+ID(ON)	VS = VD = +14V, S1/S2/S3/S4	1	+25°C	-2	2	nA
			2, 3	-55°C to +125°C	-100	100	nA
	-ID(ON)	VS = VD = -14V, S1/S2/S3/S4	1	+25°C	-2	2	nA
			2, 3	-55°C to +125°C	-100	100	nA
Low Level Input Address Current	IAL	All Channels VA = 0.8V	1	+25°C	-1	1	μA
			2, 3	-55°C to +125°C	-1	1	μA
High Level Input Address Current	IAH	All Channels VA = 4.0V	1	+25°C	-1	1	μA
			2, 3	-55°C to +125°C	-1	1	μA

Specifications HS-3XXRH/883S

TABLE 1. HS-302RH/303RH/384RH/390RH/883S DC ELECTRICAL PERFORMANCE CHARACTERISTICS

Device Guaranteed and 100% Tested. Unless Otherwise Specified: V- = -15V, V+ = +15V, VAH = +4.0V, VAL = 0.8V (Continued)

PARAMETER	SYMBOL	CONDITIONS	GROUP A SUB-GROUPS	TEMPERATURE	LIMITS		UNITS
					MIN	MAX	
Positive Supply Current	I(+)	All Channels VA = 0.8V	1	+25°C	-	10	μA
			2, 3	-55°C to +125°C	-	100	μA
		VA1 = 0V, VA2 = 4.0V and VA1 = 4.0V, VA2 = 0V	1	+25°C	-	0.5	mA
			2, 3	-55°C to +125°C	-	1	mA
Negative Supply Current	I(-)	All Channels VA = 0.8V	1	+25°C	-10	-	μA
			2, 3	-55°C to +125°C	-100	-	μA
		VA1 = 0V, VA2 = 4.0V and VA1 = 4.0V, VA2 = 0V	1	+25°C	-10	-	μA
			2, 3	-55°C to +125°C	-100	-	μA

TABLE 1. HS-306RH/307RH/883S DC ELECTRICAL PERFORMANCE CHARACTERISTICS

Device Guaranteed and 100% Tested. Unless Otherwise Specified: V- = -15V, V+ = +15V, VAH = +11.0V, VAL = 3.5V

PARAMETER	SYMBOL	CONDITIONS	GROUP A SUB-GROUPS	TEMPERATURE	LIMITS		UNITS
					MIN	MAX	
"Switch On" Resistance	+RDS	VD = 10V, IS = -10mA, S1/S2/S3/S4	1	+25°C	-	50	Ω
			2, 3	-55°C to +125°C	-	75	Ω
	+RDS	VD = -10V, IS = 10mA, S1/S2/S3/S4	1	+25°C	-	50	Ω
			2, 3	-55°C to +125°C	-	75	Ω
Leakage Current Into the Source Terminal of an "Off" Switch	+IS(OFF)	VS = +14V, VD = -14V, S1/S2/S3/S4	1	+25°C	-2	2	nA
			2, 3	-55°C to +125°C	-100	100	nA
	-IS(OFF)	VS = -14V, VD = +14V, S1/S2/S3/S4	1	+25°C	-2	2	nA
			2, 3	-55°C to +125°C	-100	100	nA
Leakage Current into the Drain Terminal of an "Off" Switch	+ID(OFF)	VS = -14V, VD = +14V, S1/S2/S3/S4	1	+25°C	-2	2	nA
			2, 3	-55°C to +125°C	-100	100	nA
	-ID(OFF)	VS = +14V, VD = -14V, S1/S2/S3/S4	1	+25°C	-2	2	nA
			2, 3	-55°C to +125°C	-100	100	nA
Leakage Current from an "On" Driver Into the Switch (Drain and Source)	+ID(ON)	VS = VD = +14V, S1/S2/S3/S4	1	+25°C	-2	2	nA
			2, 3	-55°C to +125°C	-100	100	nA
	-ID(ON)	VS = VD = -14V, S1/S2/S3/S4	1	+25°C	-2	2	nA
			2, 3	-55°C to +125°C	-100	100	nA
Low Level Input Address Current	IAL	All Channels VA = 3.5V	1	+25°C	-1	1	μA
			1, 2	-55°C to +125°C	-1	1	μA
High Level Input Address Current	IAH	All Channels VA = 11V	1	+25°C	-1	1	μA
			1, 2	-55°C to +125°C	-1	1	μA

Spec Number **518526**

■ 4302271 0063370 635 ■

Specifications HS-3XXRH/883S

TABLE 1. HS-306RH/307RH/883S DC ELECTRICAL PERFORMANCE CHARACTERISTICS

Device Guaranteed and 100% Tested. Unless Otherwise Specified: V- = -15V, V+ = +15V, VAH = +11.0V, VAL = 3.5V (Continued)

PARAMETER	SYMBOL	CONDITIONS	GROUP A SUB- GROUPS	TEMPERATURE	LIMITS		UNITS
					MIN	MAX	
Positive Supply Current	I(+)	All Channels VA = 0V	1	+25°C	-	10	μA
			2, 3	-55°C to +125°C	-	100	μA
		All Channels VA = 15V	1	+25°C	-	10	μA
			2, 3	-55°C to +125°C	-	100	μA
Negative Supply Current	I(-)	All Channels VA = 0V	1	+25°C	-10	-	μA
			2, 3	-55°C to +125°C	-100	-	μA
		All Channels VA = 15V	1	+25°C	-10	-	μA
			2, 3	-55°C to +125°C	-100	-	μA

TABLE 2. HS-302RH/303RH/384RH/390RH/883S AC ELECTRICAL PERFORMANCE CHARACTERISTICS

Device Guaranteed and 100% Tested. Unless Otherwise Specified: V- = -15V, V+ = +15V, VAH = +4.0V, VAL = 0V

PARAMETER	SYMBOL	CONDITIONS	GROUP A SUB- GROUPS	TEMPERATURE	LIMITS		UNITS
					MIN	MAX	
Break-Before-Make Time Delay (HS-303RH & 390RH Only)	TOPEN	RL = 300Ω, VS = +3V, VAH = 5V	9	+25°C	30	150	ns
			10, 11	-55°C to +125°C	-	300	ns
Switch Turn "On" Time	TON	RL = 300Ω, VS = +3V	9	+25°C	-	300	ns
			10, 11	-55°C to +125°C	-	500	ns
Switch Turn "Off" Time	TOFF	RL = 300Ω, VS = +3V	9	+25°C	-	250	ns
			10, 11	-55°C to +125°C	-	450	ns

TABLE 2. HS-306RH/307RH/883S AC ELECTRICAL PERFORMANCE CHARACTERISTICS

Device Guaranteed and 100% Tested. Unless Otherwise Specified: V- = -15V, V+ = +15V, VAH = +15.0V, VAL = 0V

PARAMETER	SYMBOL	CONDITIONS	GROUP A SUB- GROUPS	TEMPERATURE	LIMITS		UNITS
					MIN	MAX	
Break-Before-Make Time Delay (HS-307RH Only)	TOPEN	RL = 300Ω, VS = +3V	9	+25°C	30	150	ns
			10, 11	-55°C to +125°C	-	300	ns
Switch Turn "On" Time	TON	RL = 300Ω, VS = +3V	9	+25°C	-	300	ns
			10, 11	-55°C to +125°C	-	500	ns
Switch Turn "Off" Time	TOFF	RL = 300Ω, VS = +3V	9	+25°C	-	250	ns
			10, 11	-55°C to +125°C	-	450	ns

Spec Number **518526**

■ 4302271 0063371 571 ■

Specifications HS-3XXRH/883S

**TABLE 3. HS-302RH/303RH/306RH/307RH/384RH/390RH/883S
ELECTRICAL PERFORMANCE CHARACTERISTICS (NOTE 1)**

Unless Otherwise Specified: HS-302RH/303RH/384RH/390RH/883S V- = -15V, V+ = +15V, VAH = +4.0V, VAL = 0V
HS-306RH/307RH/883S V- = -15V, V+ = +15V, VAH = +15.0V, VAL = 0V

PARAMETER	SYMBOL	(NOTE 1) CONDITIONS	TEMPERATURE	LIMITS		UNITS
				MIN	MAX	
Switch Input Capacitance	CIS(OFF)	Measured Source to GND	+25°C	-	28	pF
Driver Input Capacitance	CC1	VA = 0V	+25°C	-	10	pF
	CC2	VA = 15V	+25°C	-	10	pF
Switch Output	COS	Measured Drain to GND	+25°C	-	28	pF
Off Isolation	VISO	VGEN = 1Vp-p, f = 1MHz	+25°C	40	-	dB
Crosstalk	VCR	VGEN = 1Vp-p, f = 1MHz	+25°C	40	-	dB
Charge Transfer	VCTE	VS = GND, CL = 0.01μF	+25°C	-	15	mV

NOTE:1. Parameters listed in Table 3 are controlled via design or process parameters and are not directly tested at final production. These parameters are lab characterized upon initial design release, or upon design changes. These parameters are guaranteed by characterization based upon data from multiple production runs which reflect lot to lot and within lot variation.

TABLE 4. HS-302RH/303RH/384RH/390RH/883S DC POST 100K RAD (Si) ELECTRICAL CHARACTERISTICS

Tested Per Mil-Std-883. Unless Otherwise Specified: HS-302RH/303RH/384RH/390RH/883S V- = -15V, V+ = +15V, VAH = +4.0V, VAL = 0.8V

PARAMETER	SYMBOL	CONDITIONS	TEMPERATURE	LIMITS		UNITS
				MIN	MAX	
"Switch On" Resistance	+RDS	VD = 10V, IS = -10mA, S1/S2/S3/S4	+25°C	-	60	Ω
	-RDS	VD = -10V, IS = 10mA, S1/S2/S3/S4	+25°C	-	60	Ω
Leakage Current Into the Source Terminal of an "Off" Switch	+IS(OFF)	VS = +14V, VD = -14V, S1/S2/S3/S4	+25°C	-100	100	nA
	-IS(OFF)	VS = -14V, VD = +14V, S1/S2/S3/S4	+25°C	-100	100	nA
Leakage Current into the Drain Terminal of an "Off" Switch	+ID(OFF)	VS = -14V, VD = +14V, S1/S2/S3/S4	+25°C	-100	100	nA
	-ID(OFF)	VS = +14V, VD = -14V, S1/S2/S3/S4	+25°C	-100	100	nA
Leakage Current from an "On" Driver Into the Switch (Drain & Source)	-ID(ON)	VS = VD = +14V, S1/S2/S3/S4	+25°C	-100	100	nA
	-ID(ON)	VS = VD = -14V, S1/S2/S3/S4	+25°C	-100	100	nA
Positive Supply Current	I(+)	All Channels VA = 0.8V	+25°C	-	100	μA
		VA1 = 0V, VA2 = 4.0V and VA1 = 4.0V, VA2 = 0V	+25°C	-	1	mA
Negative Supply Current	I(-)	All Channels VA = 0.8V	+25°C	-100	-	μA
		VA1 = 0V, VA2 = 4.0V and VA1 = 4.0V, VA2 = 0V	+25°C	-100	-	μA
High Level Address Current	IAH	All Channels High	+25°C	-1	+1	μA
Low Level Address Current	IAL	All Channels Low	+25°C	-1	+1	μA
Break-Before-Make Time Delay (HS-303RH/883S and HS390RH/883S Only)	TOPEN	RL = 300Ω, VS = +3V, (Note 1)	+25°C	2	300	ns
Switch Turn-On Time	TON	RL = 300Ω, VS = +3V, (Note 2)	+25°C	-	500	ns
Switch Turn-Off Time	TOFF	RL = 300Ω, VS = +3V, (Note 2)	+25°C	-	450	ns

NOTES:

1. VAL = 0V; VAH = 5.0V
2. VAL = 0V; VAH = 4.0

Spec Number **518526**

4302271 0063372 408

Specifications HS-3XXRH/883S

TABLE 4. HS-306/307RH/883S DC POST 100K RAD (SI) ELECTRICAL CHARACTERISTICS

Tested Per Mil-Std-883. Unless Otherwise Specified: HS-306RH/307RH/883S V- = -15V, V+ = +15V, VAH = +11.0V, VAL = 3.5V

PARAMETER	SYMBOL	CONDITIONS	TEMPERATURE	LIMITS		UNITS
				MIN	MAX	
"Switch On" Resistance	+RDS	VD = 10V, IS = -10mA, S1/S2/S3/S4	+25°C	-	60	Ω
	-RDS	VD = -10V, IS = 10mA, S1/S2/S3/S4	+25°C	-	60	Ω
Leakage Current Into the Source Terminal of an "Off" Switch	+IS(OFF)	VS = +14V, VD = -14V, S1/S2/S3/S4	+25°C	-100	100	nA
	-IS(OFF)	VS = -14V, VD = +14V, S1/S2/S3/S4	+25°C	-100	100	nA
Leakage Current into the Drain Terminal of an "Off" Switch	+ID(OFF)	VS = -14V, VD = +14V, S1/S2/S3/S4	+25°C	-100	100	nA
	-ID(OFF)	VS = +14V, VD = -14V, S1/S2/S3/S4	+25°C	-100	100	nA
Leakage Current from an "On" Driver Into the Switch (Drain & Source)	-ID(ON)	VS = VD = +14V, S1/S2/S3/S4	+25°C	-100	100	nA
	-ID(ON)	VS = VD = -14V, S1/S2/S3/S4	+25°C	-100	100	nA
Positive Supply Current	I(+)	All Channels VA = 0V	+25°C	-	100	μA
		All Channels VA = 15V	+25°C	-	1	mA
Negative Supply Current	I(-)	All Channels VA = 0V	+25°C	-100	-	μA
		All Channels VA = 15V	+25°C	-100	-	μA
High Level Address Current	IAH	All Channels High	+25°C	-1	+1	μA
Low Level Address Current	IAL	All Channels Low	+25°C	-1	+1	μA
Break-Before-Make Time Delay (HS-307RH/883S Only)	TOPEN	RL = 300Ω, VS = +3V, (Note 1)	+25°C	2	300	ns
Switch Turn-On Time	TON	RL = 300Ω, VS = +3V, (Note 1)	+25°C	-	500	ns
Switch Turn-Off Time	TOFF	RL = 300Ω, VS = +3V, (Note 1)	+25°C	-	450	ns

NOTE: 1. VAL = 0V; VAH = 15V

TABLE 5. HS-302RH/303RH/384RH/390RH/883S DC POST BURN-IN DELTA ELECTRICAL CHARACTERISTICS

Guaranteed, Per Mil-Std-883. Unless Otherwise Specified: V- = -15V, V+ = +15V, VAH = +4.0V, VAL = 0.8V

PARAMETER	SYMBOL	CONDITIONS	GROUP A SUB-GROUPS	TEMPERATURE	LIMITS		UNITS
					MIN	MAX	
"Switch On" Resistance	+RDS	VD = 10V, IS = -10mA, S1/S2/S3/S4	1	+25°C	-5	5	Ω
	-RDS	VD = -10V, IS = 10mA, S1/S2/S3/S4	1	+25°C	-5	5	Ω
Leakage Current Into the Source Terminal of an "Off" Switch	+IS(OFF)	VS = +14V, VD = -14V, S1/S2/S3/S4	1	+25°C	-2	2	nA
	-IS(OFF)	VS = -14V, VD = +14V, S1/S2/S3/S4	1	+25°C	-2	2	nA
Leakage Current into the Drain Terminal of an "Off" Switch	+ID(OFF)	VS = -14V, VD = +14V, S1/S2/S3/S4	1	+25°C	-2	2	nA
	-ID(OFF)	VS = +14V, VD = -14V, S1/S2/S3/S4	1	+25°C	-2	2	nA
Leakage Current from an "On" Driver Into the Switch (Drain & Source)	+ID(ON)	VS = VD = +14V, S1/S2/S3/S4	1	+25°C	-2	2	nA
	-ID(ON)	VS = VD = -14V, S1/S2/S3/S4	1	+25°C	-2	2	nA

Spec Number **518526**

4302271 0063373 344

Specifications HS-3XXRH/883S

TABLE 5. HS-302RH/303RH/384RH/390RH/883S DC POST BURN-IN DELTA ELECTRICAL CHARACTERISTICS

Guaranteed, Per Mil-Std-883. Unless Otherwise Specified: V- = -15V, V+ = +15V, VAH = +4.0V, VAL = 0.8V (Continued)

PARAMETER	SYMBOL	CONDITIONS	GROUP A SUB-GROUPS	TEMPERATURE	LIMITS		UNITS
					MIN	MAX	
Low Level Input Address Current	IAL	All Channels VA = 0.8V	1	+25°C	-100	100	nA
High Level Input Address Current	IAH	All Channels VA = 4.0V	1	+25°C	-100	100	nA
Positive Supply Current	I(+)	All Channels VA = 0.8V	1	+25°C	-1	1	μA
		VA1 = 0V, VA2 = 4.0V and VA1 = 4.0V, VA2 = 0V	1	+25°C	-0.1	0.1	mA
Negative Supply Current	I(-)	All Channels VA = 0.8V	1	+25°C	-1	1	μA
		VA1 = 0V, VA2 = 4.0V and VA1 = 4.0V, VA2 = 0V	1	+25°C	-1	1	μA

TABLE 5. HS-306RH/307RH/883S DC POST BURN-IN DELTA ELECTRICAL CHARACTERISTICS

Guaranteed, Per Mil-Std-883. Unless Otherwise Specified: V- = -15V, V+ = +15V, VAH = +11.0V, VAL = 3.5V

PARAMETER	SYMBOL	CONDITIONS	GROUP A SUBGROUPS	TEMPERATURE	LIMITS		UNITS
					MIN	MAX	
"Switch On" Resistance	+RDS	VD = 10V, IS = -10mA, S1/S2/S3/S4	1	+25°C	-5	5	Ω
	-RDS	VD = -10V, IS = 10mA, S1/S2/S3/S4	1	+25°C	-5	5	Ω
Leakage Current Into the Source Terminal of an "Off" Switch	+IS(OFF)	VS = +14V, VD = -14V, S1/S2/S3/S4	1	+25°C	-2	2	nA
	-IS(OFF)	VS = -14V, VD = +14V, S1/S2/S3/S4	1	+25°C	-2	2	nA
Leakage Current into the Drain Terminal of an "Off" Switch	+ID(OFF)	VS = -14V, VD = +14V, S1/S2/S3/S4	1	+25°C	-2	2	nA
	-ID(OFF)	VS = +14V, VD = -14V, S1/S2/S3/S4	1	+25°C	-2	2	nA
Leakage Current from an "On" Driver Into the Switch (Drain & Source)	+ID(ON)	VS = VD = +14V, S1/S2/S3/S4	1	+25°C	-2	2	nA
	-ID(ON)	VS = VD = -14V, S1/S2/S3/S4	1	+25°C	-2	2	nA
Low Level Input Address Current	IAL	All Channels VA = 3.5V	1	+25°C	-100	100	nA
High Level Input Address Current	IAH	All Channels VA = 11V	1	+25°C	-100	100	nA
Positive Supply Current	I(+)	All Channels VA = 0V	1	+25°C	-1	1	μA
		All Channels VA = 15V	1	+25°C	-1	1	μA
Negative Supply Current	I(-)	All Channels VA = 0V	1	+25°C	-1	1	μA
		All Channels VA = 15V	1	+25°C	-1	1	μA

4302271 0063374 280

Specifications HS-3XXRH/883S

TABLE 6. APPLICABLE SUBGROUPS

CONFORMANCE GROUPS		METHOD	GROUP A SUBGROUPS	
			TESTED	RECORDED
Initial Test		100%/5004	1, 7, 9	1, (Note 2)
Interim Test		100%/5004	1, 7, 9, Deltas	1, Deltas, (Note 2)
PDA		100%/5004	1, 7, Deltas	
Final Test		100%/5004	2, 3, 8A, 8B, 10, 11	
Group A (Note 1)		Sample/5005	1, 2, 3, 7, 8A, 8B, 9, 10, 11	
Group B	Subgroup B-5	Sample/5005	1, 2, 3, 7, 8A, 8B, 9, 10, 11, Deltas	1, 2, 3, Deltas, (Note 2)
	Subgroup B-6	Sample/5005	1, 7, 9	
Group D		Sample/5005	1, 7, 9	
Group E, Subgroup 2		Sample/5005	1, 7	

NOTES:

1. Alternate Group A testing in accordance with Method 5005 of MIL-STD-883 may be exercised.
2. Table 5 parameters on.y.

Harris Space Level Product Flow

Wafer Lot Acceptance (All Lots) Method 5007 (Includes SEM)	100% Interim Electrical Test (T1)
GAMMA Radiation Verification (Each Wafer) Method 1019, 4 Samples/Wafer, 0 Rejects	100% Delta Calculation (T0-T1)
100% Nondestructive Bond Pull, Method 2023	100% PDA, Method 5004 (Note 1)
Sample - Wire Bond Pull Monitor, Method 2011	100% Dynamic Burn-In, Condition D, 240 hrs., +125°C or Equivalent, Method 1015
Sample - Die Shear Monitor, Method 2019 or 2027	100% Interim Electrical Test (T2)
100% Internal Visual Inspection, Method 2010, Condition A	100% Delta Calculation (T0-T2)
100% Temperature Cycle, Method 1010, Condition C, 10 Cycles	100% PDA, Method 5004 (Note 1)
100% Constant Acceleration, Method 2001, Condition per Method 5004	100% Final Electrical Test
100% PIND, Method 2020, Condition A	100% Fine/Gross Leak, Method 1014
100% External Visual	100% Radiographic, Method 2012 (Note 2)
100% Serialization	100% External Visual, Method 2009
100% Initial Electrical Test (T0)	Sample - Group A, Method 5005 (Note 3)
100% Static Burn-In 1, Condition A or B, 72hrs. min., +125°C min.	Sample - Group B, Method 5005
	Sample - Group D, Method 5005
	100% Data Package Generation (Note 4)

NOTES:

1. Failures from subgroup 1, 7 and deltas are used for calculating PDA. The maximum allowable PDA = 5% with no more than 3% of the failures from subgroup 7.
2. Radiographic (X-Ray) inspection may be performed at any point after serialization as allowed by Method 5004.
3. Alternate Group A testing may be performed as allowed by MIL-STD-883, Method 5005.
4. Data Package Contents:
 - Cover Sheet (Harris Name and/or Logo, P.O. Number, Customer Part Number, Lot Date Code, Harris Part Number, Lot Number, Quantity).
 - Wafer Lot Acceptance Report (Method 5007). Includes reproductions of SEM photos with percent of step coverage.
 - GAMMA Radiation Report. Contains Cover page, disposition, Rad Dose, Lot Number, Test Package used, Specification Numbers, Test equipment, etc. Radiation Read and Record data on file at Harris.
 - X-Ray report and film. Includes penetrometer measurements.
 - Screening, Electrical, and Group A attributes (Screening attributes begin after package seal).
 - Lot Serial Number Sheet (Good units serial number and lot number).
 - Variables Data (All Delta operations). Data is identified by serial number. Data header includes lot number and date of test. (See Table 6)
 - Group B and D attributes and/or Generic data.
 - The Certificate of Conformance is a part of the shipping invoice and is not part of the Data Book. The Certificate of Conformance is signed by an authorized Quality Representative.

Irradiation Circuits

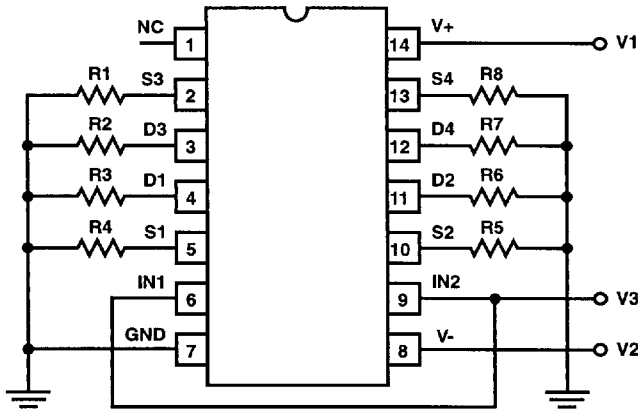

HS-302RH/303RH/883S
HS-384RH/390RH/883S

NOTES:

1. R1 - R8 = $10k\Omega \pm 5\%$, 1/4W
2. V1 = $+15V \pm 10\%$
3. V2 = $-15V \pm 10\%$
4. V3 = $+5V \pm 10\%$
5. All irradiation testing is performed in the 14 pin package.

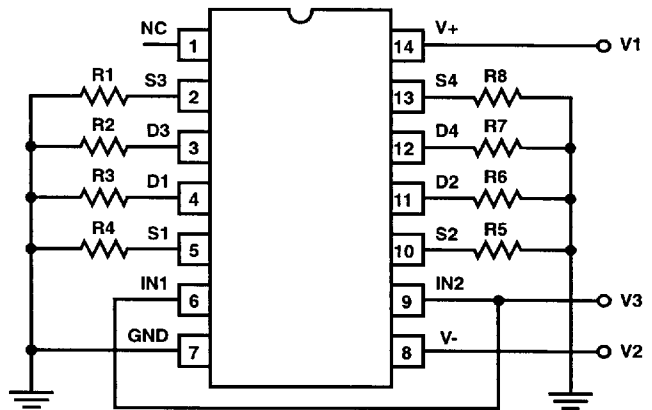

HS-306RH/307RH/883S

NOTES:

1. R1 - R8 = $10k\Omega \pm 5\%$, 1/4W
2. V1 = $+15V \pm 10\%$
3. V2 = $-15V \pm 10\%$
4. V3 = $+12V \pm 10\%$
5. All irradiation testing is performed in the 14 pin package.

Burn-In Circuits

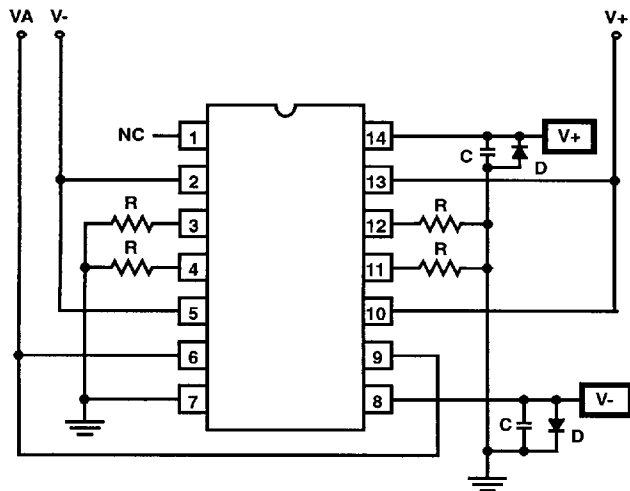

STATIC CONFIGURATION
HS-302RH/303RH/306RH/307RH/883S

NOTES:

1. R = $10K\Omega \pm 5\%$, 1/4W (4 per position)
2. C = $0.01\mu F$ minimum (per position) or $0.1\mu F$ minimum per row
3. D = IN4002 (or equivalent)
4. +V = $+15.5V \pm 0.5V$, -V = $-15.5V \pm 0.5V$
5. VA = $+15.5V \pm 0.5V$ for 306RH/307RH
6. VA = $+5.5V \pm 0.5V$ for 302RH/303RH

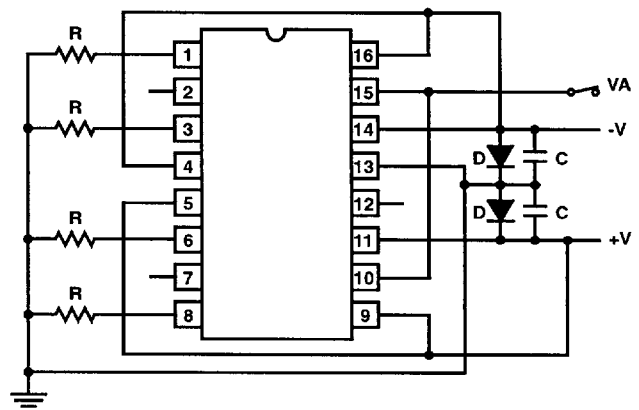

STATIC CONFIGURATION
HS-384RH/390RH/883S

NOTES:

1. R = $10K\Omega \pm 5\%$, 1/4W (4 per position)
2. C = $0.01\mu F$ minimum (per position) or $0.1\mu F$ minimum per row
3. D = IN4002 (or equivalent)
4. +V = $+15.5V \pm 0.5V$, -V = $-15.5V \pm 0.5V$
5. VA = $+5.5V \pm 0.5V$

Burn-In Circuits (Continued)

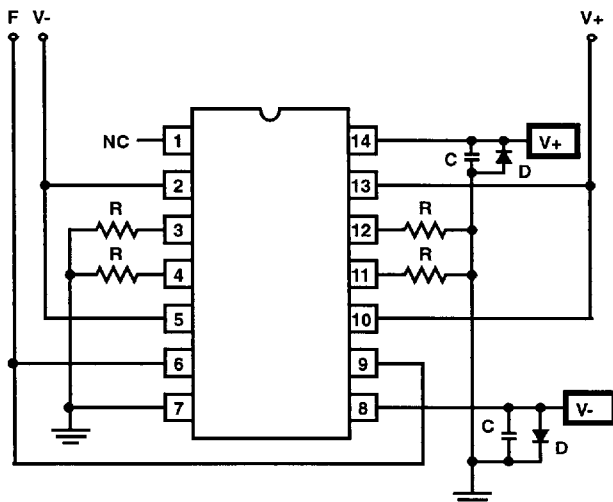

DYNAMIC CONFIGURATION
HS-302RH/303RH/883S

NOTES:

1. R = $10K\Omega \pm 5\%$, 1/4W (4 per position)
2. C = $0.01\mu F$ minimum (per position) or $0.1\mu F$ minimum per row
3. D = IN4002 (or equivalent)
4. F = 100kHz square wave, 50% duty cycle, VL = 0.8V max., VH = $5.5V \pm 0.5V$
5. +V = $+15.5V \pm 0.5V$, -V = $-15.5V \pm 0.5V$

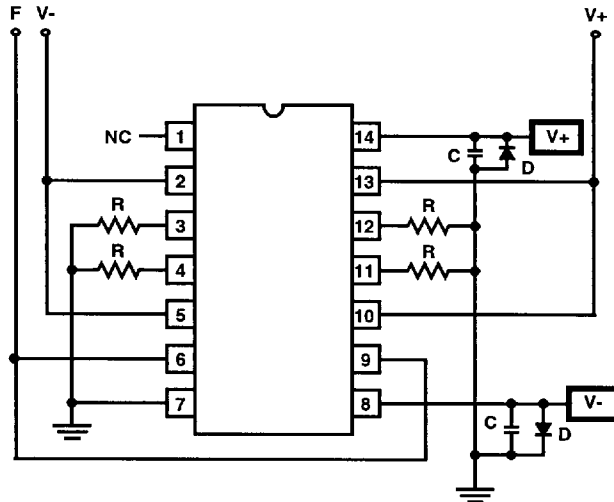

DYNAMIC CONFIGURATION
HS-306RH/307RH/883S

NOTES:

1. R = $10K\Omega \pm 5\%$, 1/4W (4 per position)
2. C = $0.01\mu F$ minimum (per position) or $0.1\mu F$ minimum per row
3. D = IN4002 (or equivalent)
4. F = 100kHz square wave, 50% duty cycle, VL = 0.8V max., VH = $14V \pm 1V$
5. +V = $+15.5V \pm 0.5V$, -V = $-15.5V \pm 0.5V$

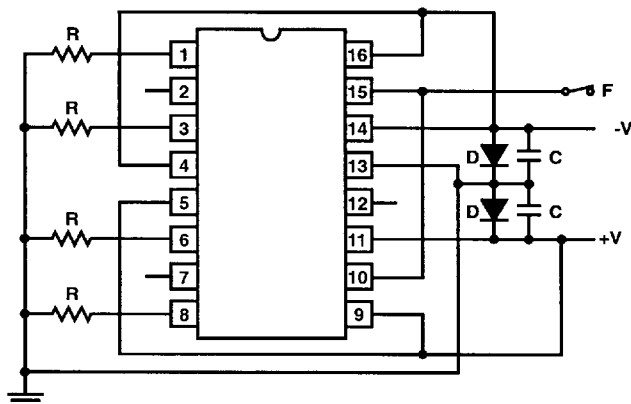

DYNAMIC CONFIGURATION
HS-384RH/390RH/883S

NOTES:

1. R = $10K\Omega \pm 5\%$, 1/4W (4 per position)
2. C = $0.01\mu F$ minimum (per position) or $0.1\mu F$ minimum per row
3. D = IN4002 (or equivalent)
4. F = 100kHz square wave, 50% duty cycle, VL = 0.8V max., VH = $+5.5V \pm 0.5V$
5. +V = $+15.5V \pm 0.5V$, -V = $-15.5V \pm 0.5V$

Test Circuits

SWITCH TYPE	V _{INH}
HS-302RH/303RH/384RH/390RH/883S	4V
HS-306RH/307RH/883S	15V

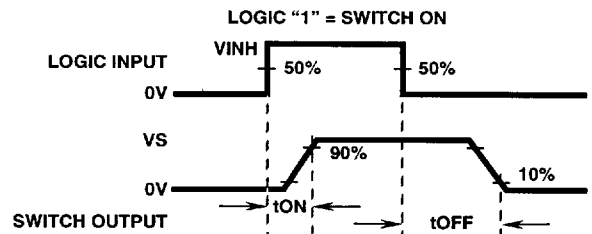
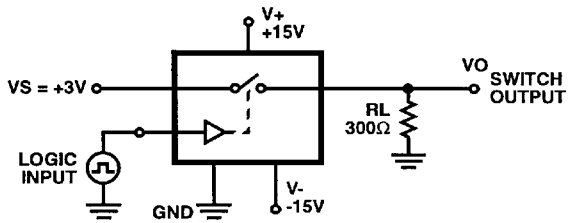

FIGURE 1. SWITCHING TEST CIRCUIT (t_{ON}, t_{OFF})

SWITCH TYPE	V _{INH}
HS-303RH/390RH/883S	5V
HS-307RH/883S	15V

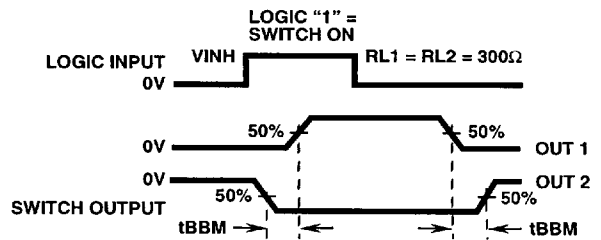
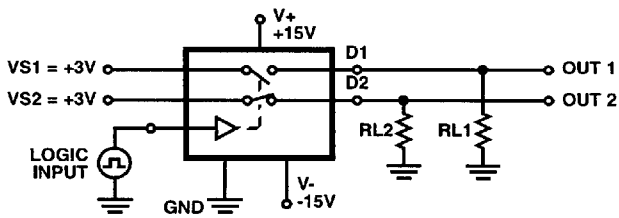

FIGURE 2. BREAK-BEFORE-MAKE TEST CIRCUIT (t_{BBM})

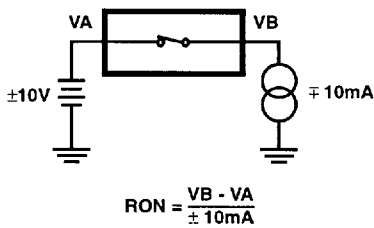

FIGURE 3. ON RESISTANCE TEST CIRCUIT (RON)

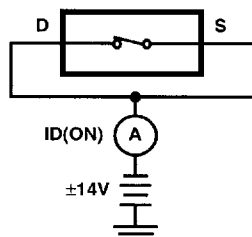

FIGURE 4. ON LEAKAGE CURRENT TEST CIRCUIT (I_{D(ON)})

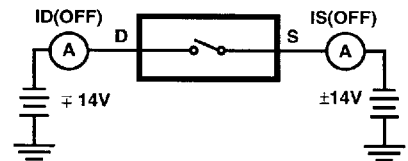

FIGURE 5. OFF LEAKAGE CURRENT TEST CIRCUIT (I_{S(OFF)}, I_{D(OFF)})

Metallization Topology

DIE DIMENSIONS:
 Die Size: 2130 x 1930 μ m
 Die Thickness: 11 \pm 1 mils

METALLIZATION:
 Type: Al, 12.5k \AA \pm 2k \AA
 Back: Gold

GLASSIVATION:
 Type: SiO₂
 Thickness: 8k \AA \pm 1k \AA

WORST CASE CURRENT DENSITY: 1.732e05 A/cm²
SUBSTRATE POTENTIAL: Unbiased
PROCESS: DI Linear Metal Gate CMOS

Metallization Mask Layout

HS-302RH/303RH/306RH/307RH/883S

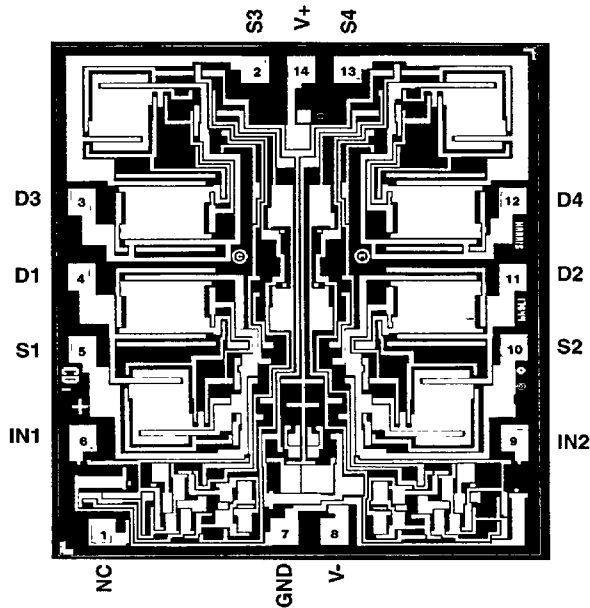

HS-384RH/390RH/883S

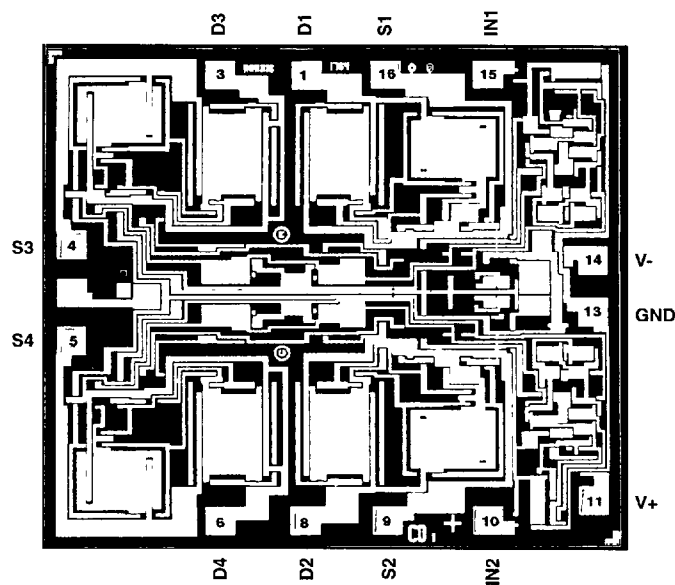

4302271 0063380 584