

710-444 Metal Multi-Branch Transitions for Series 72 & 74 Tubing and Series 75 Conduit

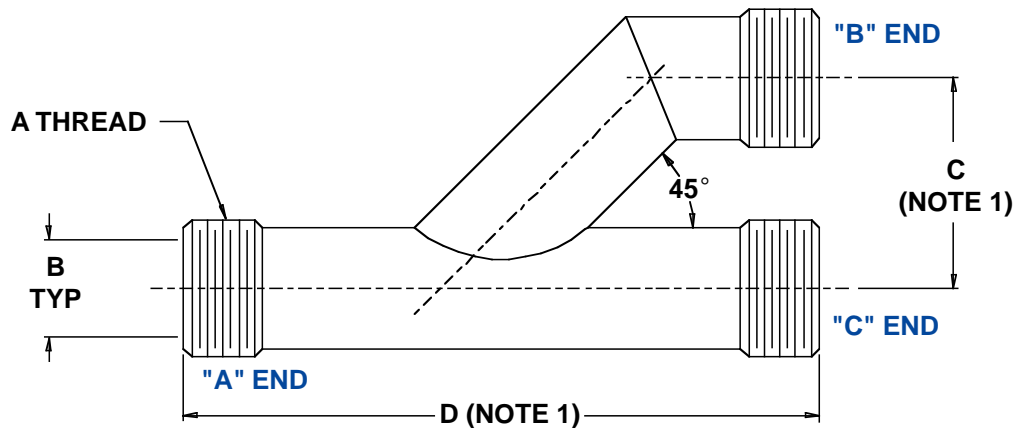
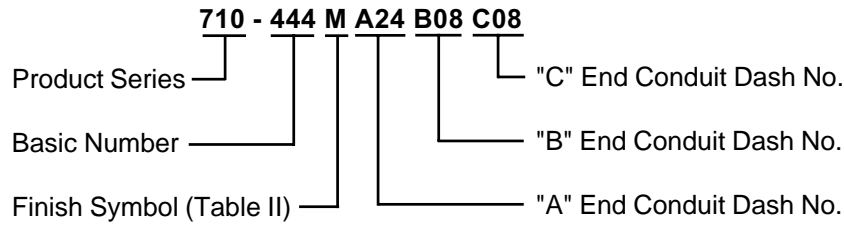

Glenair also offers numerous other branch assembly designs not presented in this catalog. Consult the factory for your specific requirements.

TABLE I

DASH AVAILABILITY				H THREAD	B	C MAX	D MAX
NO.	72	74	75	CLASS 2A		(NOTE 1)	(NOTE 1)
06		06		7/16 - 28 UNEF	.192 (4.97)	1.09 (27.7)	2.51 (63.8)
08			08	1/2 - 20 UNF	.255 (6.5)	1.16 (29.5)	2.60 (66.0)
09		09	09	9/16 - 24 UNEF	.286 (7.3)	1.22 (31.0)	2.68 (68.1)
10			10	9/16 - 24 UNEF	.317 (8.1)	1.22 (31.0)	2.69 (68.3)
12	12	12	12	5/8 - 24 UNEF	.380 (9.7)	1.28 (32.5)	2.78 (70.6)
14			14	11/16 - 24 UNEF	.442 (11.2)	1.34 (34.0)	2.87 (72.9)
16	16	16	16	3/4 - 20 UNEF	.505 (12.8)	1.41 (35.8)	2.95 (74.9)
20	20	20	20	7/8 - 20 UNEF	.630 (16.0)	1.53 (38.9)	3.13 (79.5)
24	24	24	24	1 - 20 UNEF	.755 (19.2)	1.66 (42.2)	3.31 (84.1)
28	28	28		1 3/16 - 18 UNEF	.880 (22.4)	1.84 (46.7)	3.55 (90.2)
32	32	32	32	1 5/16 - 18 UNEF	1.005 (25.5)	1.97 (50.0)	3.72 (94.5)
40	40	40	40	1 1/2 - 18 UNEF	1.255 (31.9)	2.16 (54.9)	4.02 (102.1)
48	48	48		1 3/4 - 18 UNS	1.505 (38.2)	2.41 (61.2)	4.67 (118.6)
56	56	56		2 - 18 UNS	1.755 (44.6)	2.66 (67.6)	5.02 (127.5)
64	64	64		2 1/4 - 16 UN	2.005 (50.9)	2.91 (73.9)	5.38 (136.7)

TABLE II

SYMBOL	FINISH
B	Olive Drab over Cadmium Plate
J	Gold Iridite over Cadmium Plate over Nickel
M	Electroless Nickel
N	Olive Drab over Cadmium Plate over Nickel
NC	Zinc Cobalt, Olive Drab
NF	Olive Drab over Cadmium Plate over Electroless Nickel (500 Hour Salt Spray)
T	Bright Dip Cadmium Plate over Nickel
Z1	Passivate

Notes:

1. C & D dimensions are determined by the largest entry ordered.
2. Metric dimensions (mm) are in parentheses.